

YAMAHA

MIDI FOOT CONTROLLER

MFC1

Operating Manual

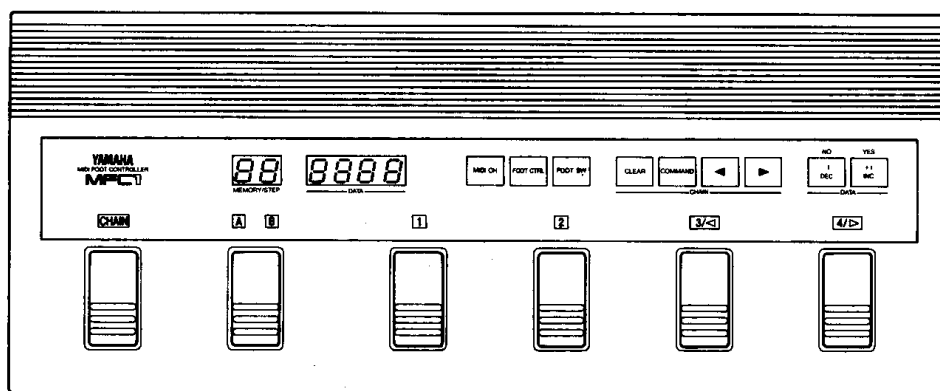

INTRODUCTION

Congratulations on your choice of a Yamaha MFC1 MIDI Foot Controller! The MFC1 is a remarkably versatile MIDI foot control device that has a tremendous range of potential applications. While offering broad control of MIDI program change and control change functions, it leaves your hands free to play an instrument or carry out other operations. The MFC1 CHAIN function is also a great plus, letting you transmit a sequence of MIDI commands just by pressing a footswitch. Of course, it's fully programmable so you can set it up to provide extra control convenience in your own particular application.

In order to make full use of the MFC1's features and functions, we recommend that you read this operation manual thoroughly and try out each operation as it is described.

CONTENTS

PRECAUTIONS	2	MIDI Channel Selection	6
THE CONNECTIONS AND CONTROLS IN BRIEF	3	Foot Control Use & Programming	6
MIDI Connections	3	Footswitch Use & Programming	7
Footswitch and Foot Control Jacks	3	CHAIN MODE	8
Power Supply	4	Outline	8
Displays	4	Accessing and Using the CHAIN Mode	8
Foot-Operated Switches	4	CHAIN Programming	8
Programming Keys	4	CHAIN CLEAR	10
MEMORY MODE	5	ERROR MESSAGES	10
Outline	5	SAMPLE APPLICATIONS	11
Program Change Numbers	5	GENERAL SPECIFICATIONS	13
Transmitting Program Change Numbers		MIDI DATA FORMAT	14
from the MFC1	5	RECEIVE DATA FOR YAMAHA MIDI EQUIPMENTS.	16
Setting Program Change Numbers	5	PROGRAM TABLE	17

PRECAUTIONS

1. AVOID EXCESSIVE HEAT AND HUMIDITY

Keep the unit away from locations where it is likely to be exposed to high temperatures or humidity—such as near radiators, stoves, etc.

2. AVOID PHYSICAL SHOCKS

Although the MFC1 is built to withstand rough foot-operated use, excessively strong physical shocks to the unit can cause damage. Handle it with care.

3. AVOID STRONG ELECTROMAGNETIC FIELDS

The MFC1 employs sophisticated digital microprocessor circuitry. To prevent data errors, keep it away from sources of electromagnetic radiation such as transformers, pumps, refrigerators, TV sets, etc.

4. HANDLE CABLES CAREFULLY

Always plug and unplug cables by gripping the cable connector, not the cord.

5. CLEAN WITH A SOFT DRY CLOTH

Never use solvents such as benzine or thinner to clean the unit. Wipe clean with a soft, dry cloth.

6. MEMORY BACKUP

The MFC1 incorporates a special long-life backup battery which will maintain user-programmed data even when the power is OFF. Battery life is approximately 5 years. When the battery needs to be replaced the MFC1 will display the "E r B A T T E R Y" message (see ERROR MESSAGES section). The battery is not user-replaceable. REFER BATTERY REPLACEMENT TO A QUALIFIED YAMAHA SERVICE CENTER!

ADVARSEL!

Lithiumbatteri!

Ekspløsningsfare. Udskiftning må kun foretages af en sagkyndig,-og som beskrevet i servicemanualen.

VAROITUS!

Lithiumparisto. Räjähdyksvaara.

Pariston saa vaihtaa ainoastaan alan ammattimies.

FCC CERTIFICATION (USA)

This equipment generates and uses radio frequency energy and if not installed and used properly, that is, in strict accordance with the manufacturer's instructions, may cause interference to radio and television reception. It has been type tested and found to comply with the limits for a Class B computing device in accordance with the specifications in Subpart J of Part 15 of FCC Rules, which are designed to provide reasonable protection against such interference in a residential installation. However, there is no guarantee that interference will not occur in a particular installation. If this equipment does cause interference to radio or television reception, which can be determined by turning the equipment off and on, the user is encouraged to try to correct the interference by one or more of the following measures:

Reorient the receiving antenna.

Relocate the computer with respect to the receiver.

Move the computer away from the receiver.

Plug the computer into a different outlet so that computer and receiver are on different branch circuits.

If necessary, the user should consult the dealer or an experienced radio/television technician for additional suggestions. The user may find the following booklet prepared by the Federal Communications Commission helpful:

"How to identify and Resolve Radio-TV interference Problems".

This booklet is available from the U.S. Government Printing Office, Washington, DC 20402, Stock No. 004-000-00345-4.

THE CONNECTIONS AND CONTROLS IN BRIEF

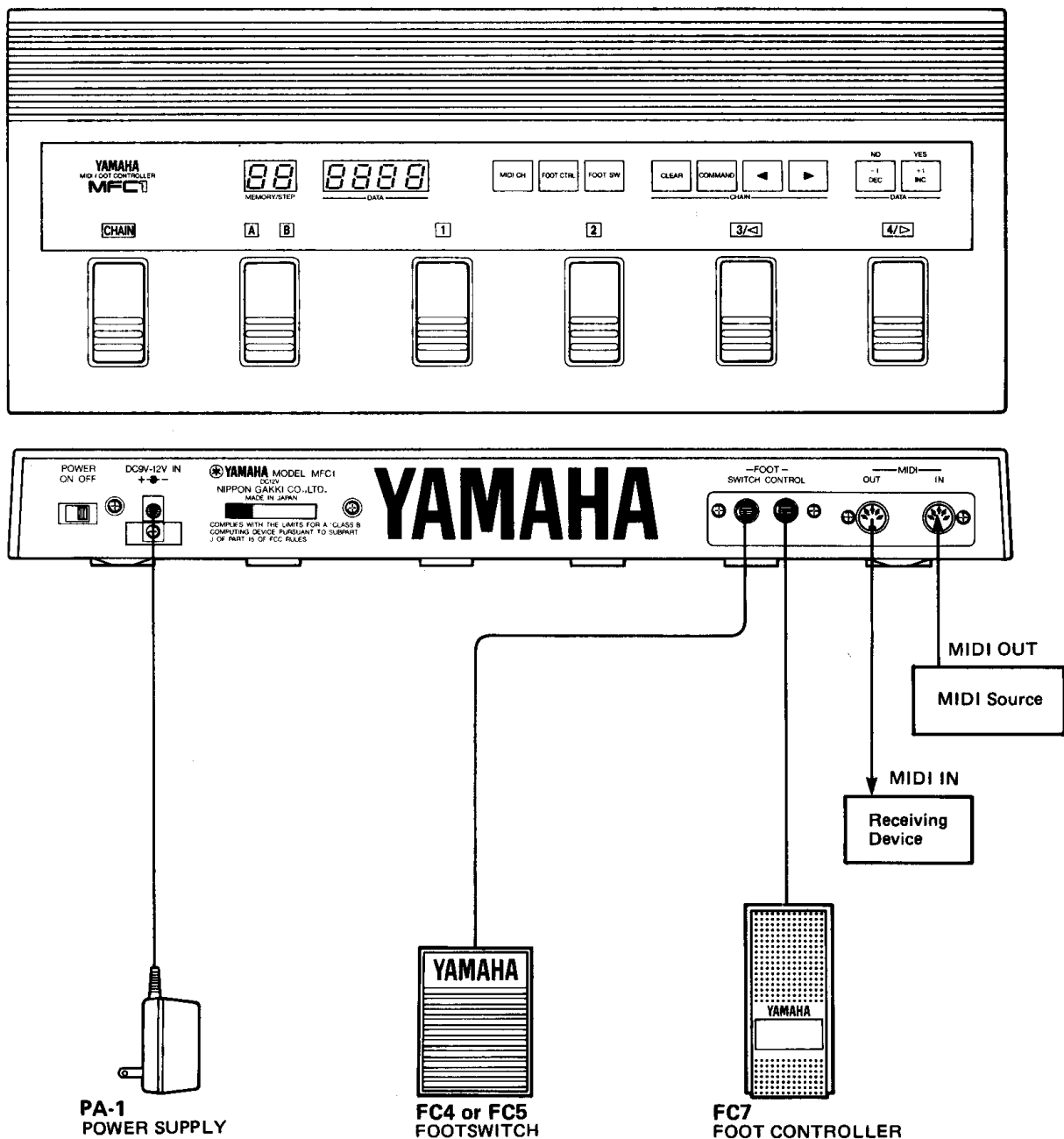

MIDI Connections

The MFC1 features both MIDI IN and MIDI OUT terminals. MIDI data generated by the MFC1 is sent via the MIDI OUT terminal, which should be connected to the MIDI IN terminal of the MIDI device to be controlled—an effect unit such as the Yamaha SPX90 Digital Multi-effect processor, a synthesizer, tone generator, sequencer, etc.

The MIDI IN terminal accepts MIDI data from an external MIDI source. Received MIDI data is merged with the data internally generated by the MFC1 and delivered via the MIDI OUT terminal. This allows you to “mix” the MIDI data from the MFC1 and any other MIDI device.

Footswitch and Foot Control Jacks

The MFC1 permits transmission of MIDI control change data via a footswitch and foot controller. To use this capability an optional footswitch and/or foot controller must be connected to the corresponding input jacks on the MFC1 rear panel. We recommend the Yamaha FC7 Foot Controller and FC4 or FC5 Footswitch.

Power Supply

The MFC1 receives its power from an external PA-1 power adaptor (supplied). Plug the adaptor's output cable into the socket provided on the rear panel of the MFC1 (DC 9V — 12V IN), then plug the adaptor itself into a convenient AC wall socket. BE SURE that your local line voltage matches that specified on the PA-1.

***NOTE:** To prevent MIDI data errors, the MFC1 and connected equipment should be turned ON in the following sequence.

1. Transmitting device connected to MFC1 MIDI IN.
2. MFC1.
3. Receiving device connected to MFC1 MIDI OUT.

Power Cord Strain Relief

A power cord strain relief hook is provided next to the DC 9V — 12V power input jack. Wrap the power cord around this hook to prevent accidental unplugging during use.

Displays

The MFC1 has two separate digital LED displays: a two-digit display labelled MEMORY/STEP, and a four-digit display labelled DATA. The MEMORY/STEP display shows the selected BANK and SWITCH number in the normal MEMORY mode, and the current STEP number in the CHAIN mode. The DATA display shows the data transmitted via the MIDI OUT jack, and parameters during programming operations. Details on the operation and use of these modes, and the meaning of the displays, will be given later in this manual.

Foot-operated Switches

These six switches are the ones you'll use when actually operating the MFC1. The leftmost switch selects either the MEMORY or CHAIN mode, the next selects either the A or B memory BANK, and the remaining four are the main data selectors in the MEMORY mode. In the CHAIN mode, the rightmost two switches perform the chain STEP decrement and increment functions. More details will be given later in this manual.

Programming Keys

The white panel keys lined up to the right of the LED displays are primarily used when programming the MFC1. They permit programming the transmission MIDI channel, foot controller data, footswitch data, and chain functions. Their use will be described in the appropriate sections of this manual.

MEMORY MODE

Outline

In the normal MEMORY mode (power-on status), pressing any one of the MFC1 switches labelled with indicator lamps 1 through 4 outputs a pre-programmed MIDI PROGRAM CHANGE number via the MIDI OUT terminal. This allows you to change effects on a MIDI compatible effect unit such as the Yamaha SPX90, change voices on MIDI synthesizers or tone generators, and perform other functions. In addition, two BANKS are provided—A and B—so a total of 8 PROGRAM CHANGE numbers may be memorized and output: A1 – A4, B1 – B4. The bank selector switch, labelled with indicator lamps A and B, selects the desired bank. The MEMORY/STEP LED display shows the currently selected bank and switch number. The DATA LED display shows the program change number transmitted by the selected BANK and SWITCH.

Program Change Numbers

The MIDI program change number is a number between 1 and 128 which selects the correspondingly numbered "program" in the MIDI receiving device. The range of program change numbers you can use will depend on the particular MIDI receiving device to which the MFC1 will be connected. A synthesizer such as the DX7, for example, will accept program change numbers 1 through 32, corresponding to its 32 internal voices. Be sure to refer to the operation manual of your MIDI receiving device for information on valid program change numbers.

Transmitting Program Change Numbers from the MFC1

As shipped, the MFC1 program change memory contains the following program change numbers:

	BANK A	BANK B
SWITCH 1	1	5
SWITCH 2	2	6
SWITCH 3	3	7
SWITCH 4	4	8

To transmit program change number 3 (BANK A, SWITCH 3), for example, simply press SWITCH 3 if BANK A is already selected (the "A" indicator will be glowing), or first press the bank selector switch to select BANK A if BANK B is selected, then press SWITCH 3. Once selected, the MEMORY/STEP LED display will read "A3," and the DATA display will read "003," corresponding to the transmitted program change number.

TRANSMITTING PROGRAM CHANGE NUMBERS IN THE MEMORY MODE.

① Select BANK A

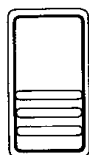

② Press SWITCH

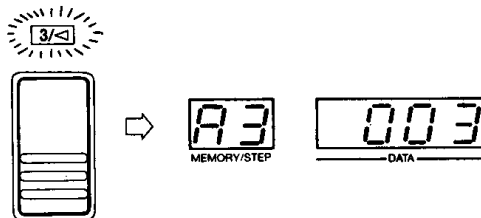

NOTE: The program change number is transmitted once when the appropriate SWITCH is pressed.

NOTE: BANK A is automatically selected when the power is initially turned ON. A SWITCH must be pressed, however, to transmit a program change number.

Setting Program Change Numbers

A new program change number can be programmed into any BANK/SWITCH memory simply by selecting the desired BANK and SWITCH as described above, then selecting the new program change number using the -1 and +1 DATA keys while watching the DATA LED display.

Once set, the new program number will be transmitted any time that BANK/SWITCH combination is selected, and it will be retained in memory even when the MFC1 power is turned OFF.

SETTING PROGRAM CHANGE NUMBERS IN THE MEMORY MODE

① Select BANK

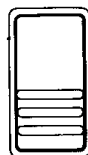

② Select SWITCH



③ Set program change number

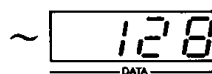
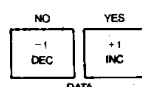

MIDI Channel Selection

The MFC1 MIDI channel programming feature is important if your MIDI receiving device receives only on a specific MIDI channel, or you have several devices "chained" and want only one of them, set to a particular MIDI channel, to respond to the MFC1.

To set the MIDI transmission channel of the MFC1, simply press the MIDI CH key while in any mode and select the desired MIDI channel number (1 through 16) using the -1 and +1 DATA keys. The selected MIDI channel number will be shown on the LED DATA display. Press the MIDI CH key again to revert to the previous mode once the new MIDI channel is set. You can also directly exit the MIDI channel programming mode by performing a different operation—such as pressing one of the switches to transmit a program change number. While the MIDI channel programming mode is active, the MEMORY/STEP display will read "CH."

Only one MIDI channel can be set for MEMORY and CHAIN mode.

SELECTING A MIDI TRANSMISSION CHANNEL

- 1 Press MIDI CH key

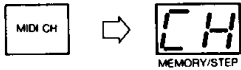

- 2 Select MIDI channel



- 3 Press MIDI CH key again



Foot Control Use & Programming

A Yamaha FC7 Foot Controller connected to the MFC1 FOOT CONTROL jack can be used to transmit MIDI control change data to perform a variety of functions—modulation control, volume control and others. The actual function performed by the foot controller depends on the programmed control change number. Control change numbers 0 through 127 can be programmed, but only specific numbers can be used with most types of MIDI equipment. The following is a list of the most useful control change numbers for foot controller use:

CONTROL CHANGE NO.	FUNCTION
01	MODULATION
02	BREATH CONTROL
04	FOOT CONTROL
05	PORTAMENTO TIME
06	DATA ENTRY
07	MAIN VOLUME

*NOTE: Not all of these functions are implemented in every MIDI device.

To program a specific control change number for the foot controller, press the FOOT CTRL key and select the desired number using the -1 and +1 DATA keys. The selected control change number will be shown on the DATA display. Press the FOOT CTRL key again to return to the previous mode. The MEMORY/STEP display will read "FC" while the foot control programming mode is active.

SETTING THE FOOT CONTROLLER CONTROL CHANGE NUMBER

- 1 Press FOOT CTRL key



- 2 Select control change number



- 3 Press FOOT CTRL key again



The actual effect of the foot controller will often depend on the setting of various parameters in the MIDI receiving device. If you select control number 01 to make the foot controller function as a modulation controller, for example, the receiving device must be set to accept the desired degree of modulation control. Refer to the operation manual of your receiving device for details.

Footswitch Use & Programming

A Yamaha FC4 or FC5 Footswitch connected to the MFC1 FOOT SWITCH jack can be used to transmit MIDI control change data to perform a variety of functions—sustain ON/OFF, portamento ON/OFF, and others. The actual function performed by the footswitch depends on the programmed control change number. Control change numbers 0 through 127 can be programmed, but only specific numbers can be used with most types of MIDI equipment. Note that since the footswitch is a simple ON/OFF device, it is only applicable to functions which require non-continuous ON/OFF control. For example, the footswitch could be programmed with control change number 07 for Main Volume control (see foot control section, above), but the result would be no volume when the switch is not pressed, and full volume when the switch is pressed—not a very useful function. The following is a list of the most useful control change numbers for footswitch control:

CONTROL CHANGE NO.	FUNCTION
64	SUSTAIN ON/OFF
65	PORTAMENTO ON/OFF
66	SOSTUNETO ON/OFF
67	SOFT ON/OFF

***NOTE:** Not all of these functions are implemented in every MIDI device.

To program a specific control change number for the footswitch, press the FOOT SW key and select the desired number using the -1 and +1 DATA keys. The selected control change number will be shown on the DATA display. Press the FOOT SW key again to return to the previous mode. The MEMORY/STEP display will read "FS" while the footswitch programming mode is active.

SETTING THE FOOT SWITCH CONTROL CHANGE NUMBER

- ① Press FOOT SW key



- ② Select control change number



- ③ Press FOOT SW key again



The actual effect of the footswitch will often depend on the setting of various parameters in the MIDI receiving device. If you select control number 66 to make the footswitch function as a portamento switch, for example, the portamento function of the receiving device must be ON and set to accept external ON/OFF control. Refer to the operation manual of your receiving device for details.

CHAIN MODE

Outline

The MFC1 CHAIN mode lets you set up 4 "chains" of up to 20 MIDI commands (STEPS) which can be transmitted in sequence simply by pressing a switch. The 4 chains are programmed into BANK A/SWITCHES 1 & 2, and BANK B/SWITCHES 1 & 2 (A1, A2, B1 and B2). In the CHAIN mode SWITCHES 3 and 4 function as the STEP decrement and increment controls (note the ◀ and ▶ markings). By pressing the 3/◀ or 4/▶ switches you can step forward or backward through the selected chain. In the CHAIN mode the MEMORY/STEP LED display shows the number of the current step in the selected chain, and the DATA display shows the type and number of the command transmitted by the selected step.

Accessing and Using the CHAIN Mode

The CHAIN mode is accessed simply by pressing the CHAIN SWITCH. The CHAIN indicator will glow when the CHAIN mode has been properly selected. When the CHAIN mode is initially selected both the MEMORY/STEP and DATA displays will be blank. If a CHAIN (BANK/SWITCH combination) is then selected, STEP 01 will be indicated by the MEMORY/STEP display, and the DATA display will show the data programmed into that step. To select a CHAIN, select the appropriate BANK (A or B) using the BANK select switch, then press either SWITCH 1 or SWITCH 2. The data programmed for the first STEP will be transmitted as soon as the BANK/SWITCH CHAIN selection is made. If no data is programmed into the selected CHAIN, the DATA display will read "-----," and no data will be transmitted.

Once a programmed CHAIN is selected, you can advance to the next STEP by pressing the 4/▶ SWITCH, or the corresponding ▶ key in the CHAIN group. Move back to the preceding STEP by pressing the 3/◀ SWITCH or the corresponding ◀ key in the CHAIN group. You will not be able to advance beyond the last programmed STEP, or move back past STEP 01.

SELECTING AND STEPPING THROUGH A CHAIN

① Select CHAIN mode

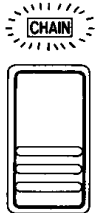

② Select BANK



③ Select SWITCH

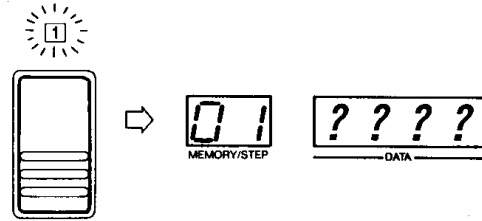

④ Increment (and decrement) through CHAIN

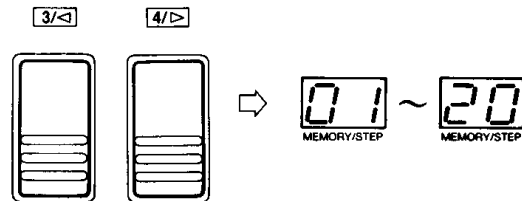

CHAIN Programming

To begin CHAIN programming first select the CHAIN to be programmed (BANK then SWITCH), and if the selected CHAIN already contains data advance to the STEP to be programmed using the 4/▶ SWITCH. For a blank CHAIN, begin programming at STEP 01. Once the first STEP to be programmed is selected, press the CHAIN COMMAND key to select the desired command. Consecutive presses on the COMMAND key scrolls through the following list of commands:

COMMAND	FUNCTION
P001	Transmit program change number.
C000	Set foot controller control change number.
S064	Set footswitch control change number.
STRT	Transmit START signal.
SToP	Transmit STOP signal.
ConT	Transmit CONTINUE signal.

In the case of the first three commands in the list—P001, C000 and S064—the first character indicates the type of command and the following three digits are the corresponding data. When any of these three commands is selected, the data can be set using the -1 and +1 DATA keys.

Program Change: P001 – P128

Foot Controller Control Change: C000 – C127

Footswitch Control Change: S000 – S127

Here, again, are the most useful control change numbers for foot controller and footswitch operation:

USEFUL FOOT CONTROLLER NUMBERS

CONTROL CHANGE NO.	FUNCTION
01	MODULATION
02	BREATH CONTROL
04	FOOT CONTROL
05	PORTAMENTO TIME
06	DATA ENTRY
07	MAIN VOLUME

*NOTE: Not all of these functions are implemented in every MIDI device.

USEFUL FOOTSWITCH NUMBERS

CONTROL CHANGE NO.	FUNCTION
64	SUSTAIN ON/OFF
65	PORTAMENTO ON/OFF
66	SOSTUNETO ON/OFF
67	SOFT ON/OFF

*NOTE: Not all of these functions are implemented in every MIDI device.

A STEP that has been programmed with program change data transmits the programmed number as soon as it is selected.

A STEP that has been programmed with a foot controller control change number or footswitch control change number changes the status of the foot control or footswitch as soon as it is selected—the foot controller or footswitch must then be operated to actually transmit the control change data.

The remaining three commands—START, STOP and CONTINUE—transmit the corresponding MIDI START, STOP and CONTINUE commands for control of MIDI digital sequence recorders, digital rhythm programmers, etc. A STEP programmed with one of these three commands transmits the command as soon as it is selected.

Once the first STEP has been programmed, press the 4/▷ SWITCH to advance to the next STEP, and continue programming in the same manner. Up to 20 STEPS can be programmed for each CHAIN. Individual STEPS in a programmed CHAIN can be reprogrammed simply by selecting the desired STEP using the 3/◁ or 4/▷ SWITCHES and programming as described above.

PROGRAMMING A CHAIN

① Select CHAIN to be programmed.

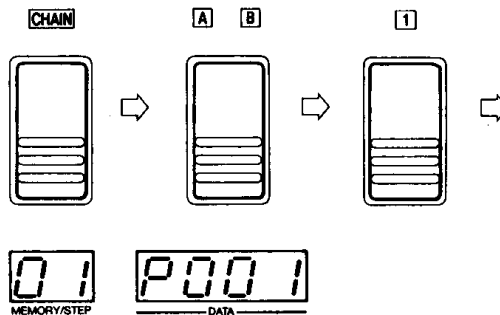

② Select COMMAND for STEP 01

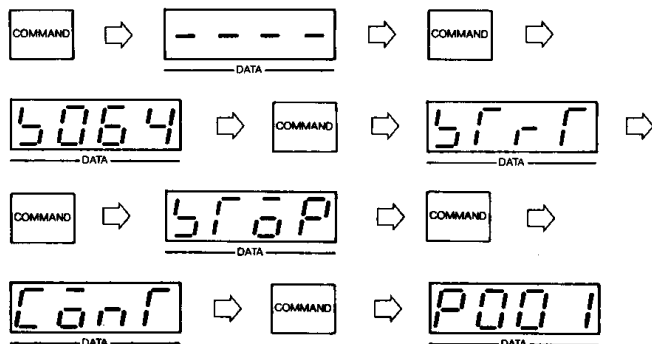

③ Set data if selected COMMAND is P001, C000 or S064

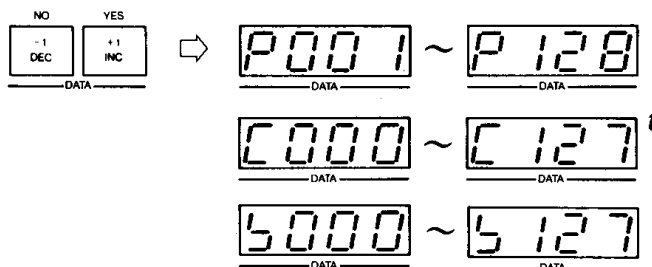

④ Select next STEP and continue programming as shown above.

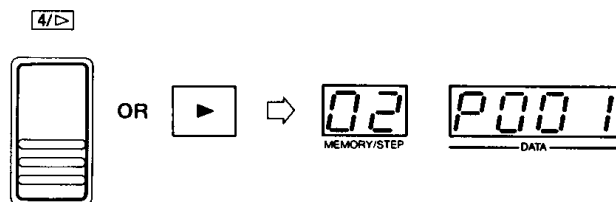

CHAIN CLEAR

This function clears the entire contents of the selected CHAIN. When the CHAIN CLEAR key is pressed, the DATA display will read "CLr?". To actually execute the CLEAR operation press the +1/YES DATA key. To abort the CLEAR operation, leaving the CHAIN intact, press the -1/NO DATA key.

CLEAR SELECTED CHAIN

① Press CLEAR key

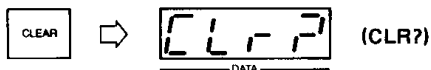

② Confirm



ERROR MESSAGES

<p>Er Line</p> <p>Er Line</p> <p>MEMORY/STEP DATA</p>	<p>Indicates a fault in a MIDI transmission line connected to the MIDI IN terminal.</p>
<p>Er FULL</p> <p>Er FULL</p> <p>MEMORY/STEP DATA</p>	<p>Buffer overflow error. Excessively complex MIDI data is being received at the MIDI IN terminal.</p>
<p>Er dATA</p> <p>Er dATA</p> <p>MEMORY/STEP DATA</p>	<p>Framing error. Unintelligible data received at the MIDI IN terminal.</p>
<p>Er bATT</p> <p>Er bATT</p> <p>MEMORY/STEP DATA</p>	<p>Low battery. The memory backup battery must be replaced. REFER THIS JOB TO A QUALIFIED YAMAHA SERVICE CENTER!</p>
<p>LoST</p> <p>LoST</p> <p>MEMORY/STEP DATA</p>	<p>Memory failure. All programmed data has been lost and initial data has been restored.</p>

SAMPLE APPLICATIONS

1. SPX90 PROGRAM SELECTION & RX21 CONTROL

In this system the MFC1 is used primarily as a program selector for the versatile Yamaha SPX90 Digital Multi-effect Processor. The SPX90 can be programmed so that specific MIDI program change numbers received at its MIDI IN terminal select specific effect programs: reverb, delay, gate, compressor, EQ, etc. Combined with an MFC1 programmed to transmit the appropriate program change numbers, therefore, it is possible to directly select up to 8 different effect programs via the footswitches while playing guitar or any other instrument. Effects could even be applied to an acoustic instrument or voice by feeding the output of a microphone preamplifier to the SPX90 input.

The RX21 Digital Rhythm Programmer can be started and stopped in the MFC1 CHAIN mode, using the START, STOP and CONTINUE commands. You could, for example, set up a CHAIN that first selects a new SPX90 program, starts the RX21, stops the RX21, selects a new SPX90 program for the next song, then starts the RX21 again, and so on.

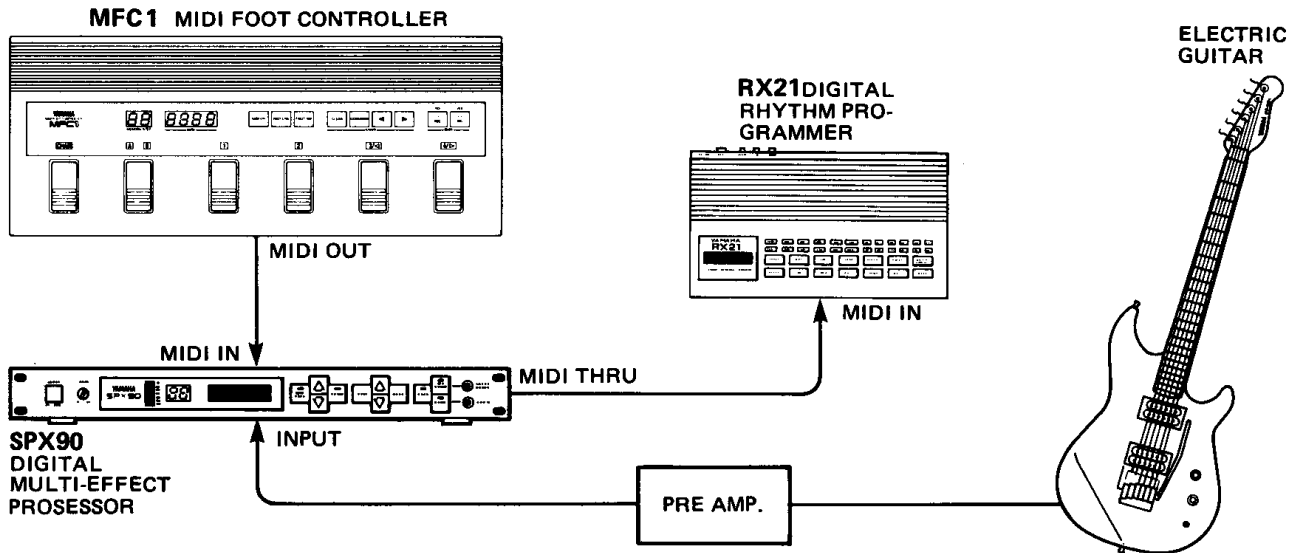

2. CONTROL A SECONDARY FM TONE GENERATOR MODULE WHILE PLAYING A MIDI ELECTRIC PIANO

The Yamaha CP60M (and CP70M CP80M) electric piano features a MIDI output which permits playing a secondary MIDI tone generator simultaneously via the piano keyboard. Adding an MFC1 to such a setup permits convenient program and function control. The MIDI output from the CP60M—consisting only of MIDI note data—is fed to the MFC1 MIDI IN terminal. The CP60M data is internally merged with the data generated by the MFC1 and sent to the TX7 FM Expander via the MFC1 MIDI OUT terminal. The MFC1 can then be programmed to transmit the appropriate program change numbers to select the desired voices on the TX7. The foot switch control number could be set to turn the TX7 portamento effect ON and OFF, and the foot controller could be programmed to provide foot modulation or volume control.

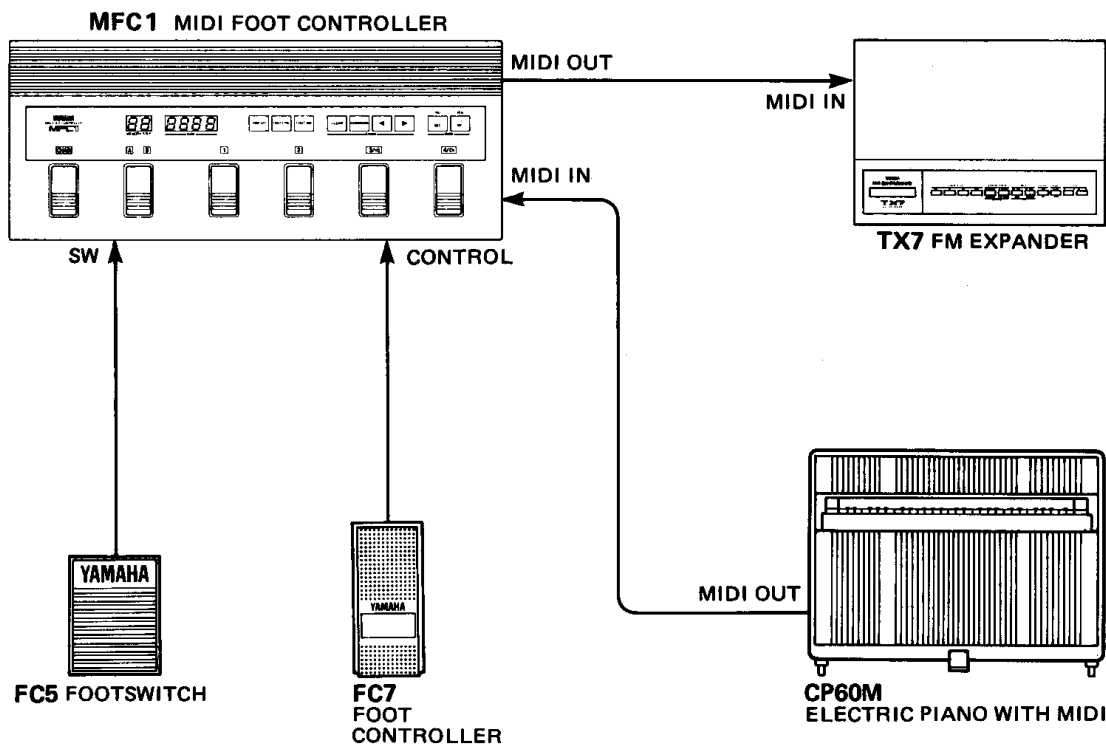

3. FOOT CONTROL OF A DIGITAL RHYTHM SECTION WHILE PLAYING ANY OTHER INSTRUMENT

This system provides versatile foot control of a sequenced digital "backup" section consisting of a QX21 Digital Sequence Recorder, TX7 FM Expander and RX21 Digital Rhythm Programmer. By using a rather unusual hookup we enable the MFC1 to provide START/STOP/CONTINUE control of the QX21 (CHAIN MODE) as well as voice selection for the TX7. The MIDI output from the MFC1 is connected to the MIDI IN terminal of the QX21, allowing the CHAIN mode START, STOP and CONTINUE commands to be used to control sequence playback. The MIDI THRU terminal of the QX21 is fed to the MIDI IN terminal of the TX7 so that program change numbers transmitted by the MFC1 are able to select TX7 voices. So far everything is fine, but the MIDI output from the QX21 can not reach the TX7 and RX21 to provide sequence playback. To solve this problem we feed the MIDI output from the QX21 back to the MIDI IN terminal of the MFC1, where it will be merged with the MFC1 data and delivered to the TX7 and RX21. In this system both the TX7 and RX21 are driven by the QX21, receiving on different MIDI channels.

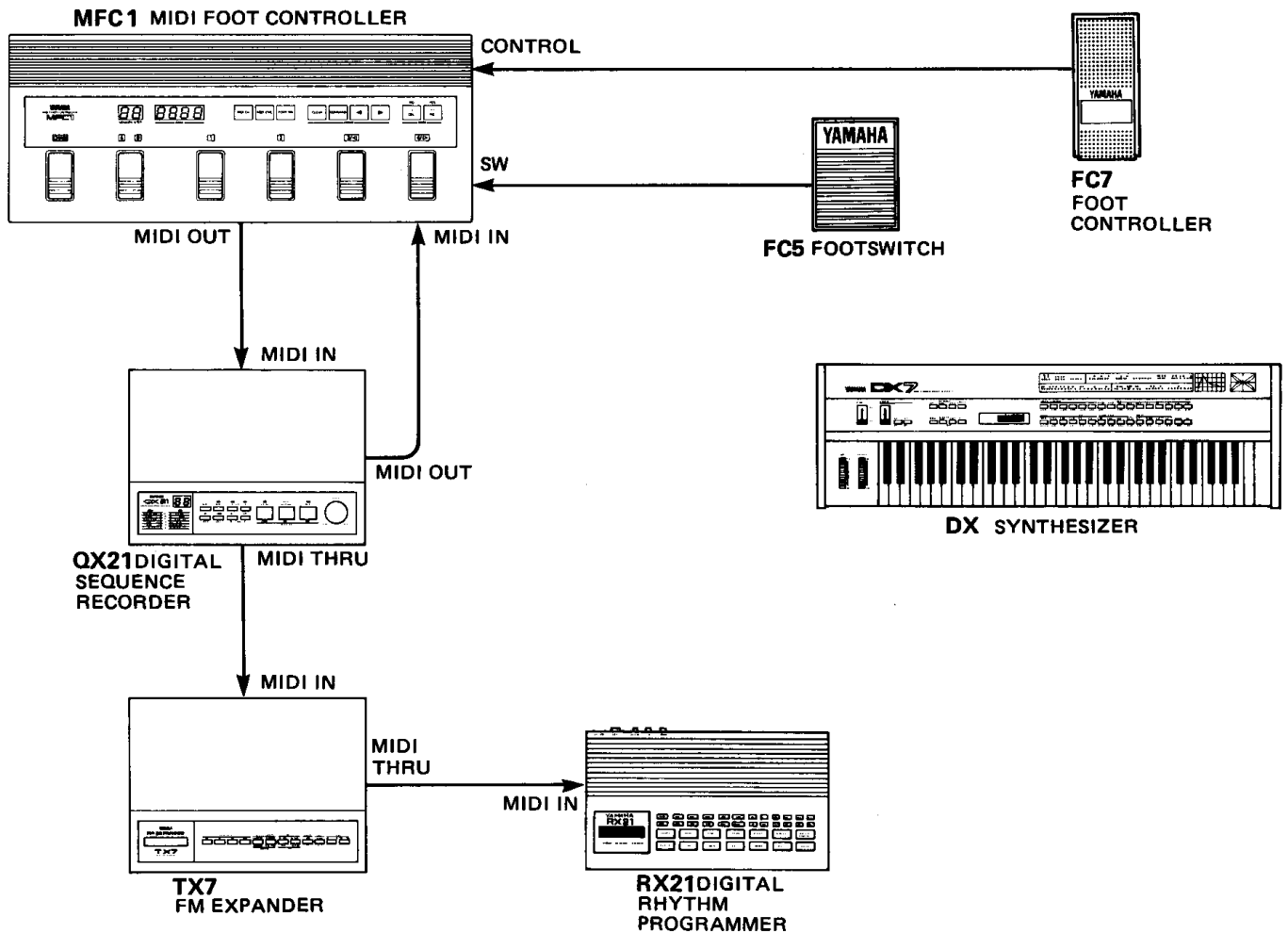

GENERAL SPECIFICATIONS

MEMORY MODE	
Memories	BANK A, 1 – 4. BANK B, 1 – 4.
Memory contents	MIDI program change numbers 001 – 128, programmable.
Footswitch	Assignable MIDI control change numbers 000 – 127.
Foot controller	Assignable MIDI control change numbers 000 – 127.

CHAIN MODE	
Chains	BANK A, 1 – 2. BANK B, 1 – 2.
Chain contents	20 STEPS per CHAIN: program change number, footswitch control change, foot controller control change, START, STOP, CONTINUE.

MIDI TRANSMISSION CHANNEL	1 – 16, programmable.
----------------------------------	-----------------------

DISPLAYS	MEMORY/STEP (7-segment, 2-digit LED). DATA (7-segment 4-digit LED). CHAIN indicator lamp. A, B bank indicator lamps. 1, 2, 3, 4 memory indicator lamps.
-----------------	---

CONNECTORS	MIDI IN, MIDI OUT, FOOT CONTROL, FOOT SWITCH, DC 9V – 12V.
-------------------	---

FOOT OPERATED SWITCHES	CHAIN, A/B, 1, 2, 3/◀, 4/▶.
-------------------------------	-----------------------------

PROGRAMMING KEYS	MIDI CH, FOOT CTRL, FOOT SW, CHAIN CLEAR, CHAIN COMMAND, CHAIN ◀, CHAIN ▶, NO/-1/DEC, YES/+1/INC.
-------------------------	---

POWER SUPPLY	Yamaha PA-1 (supplied). U.S. & Canadian models 110V – 120V General model 220V – 240V
---------------------	--

DIMENSIONS	466 mm x 53 mm x 197 mm (18-3/8" x 2-1/8" x 7-3/4")
-------------------	---

WEIGHT	1.7 kg (3.7 lbs)
---------------	------------------

MIDI DATA FORMAT

1. Transmission Conditions

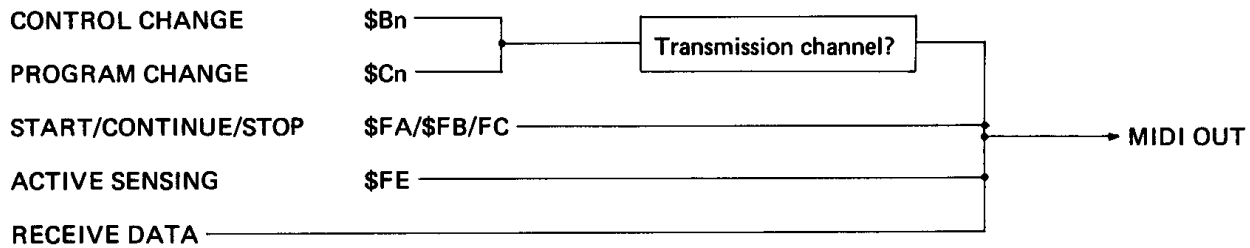

2. Transmission Data

Transmission channels 1 – 16 can be selected.

2-1. Channel Information

- Channel Voice Message

(1) Control Change

Status	1 0 1 1 n n n n (Bn)	n = channel no. (1 – 16)
Control no.	0 c c c c c c c	c = control no. (0 – 127)
Control value	0 v v v v v v v	v = control no. (0 – 127)

(2) Program Change

Status	1 1 0 0 n n n n (Cn)	n = channel no. (1 – 16)
Program no.	0 p p p p p p p	p = program no. (1 – 128)

2-2. System Information

- System Real-time Message

(1) START

Status	1 1 1 1 1 0 1 0 (FA)
--------	----------------------

(2) CONTINUE

Status	1 1 1 1 1 0 1 1 (FB)
--------	----------------------

(3) STOP

Status	1 1 1 1 1 1 0 0 (FC)
--------	----------------------

(4) Active Sensing

Status	1 1 1 1 1 1 1 0 (FE)*
--------	-----------------------

* If no data is transmitted within 150 ms after transmission of data containing an active sensing status byte, a clock byte is transmitted.

** Status byte abbreviation (running status) is carried out for transmission.

3. Reception Data

This unit receives and transmits all MIDI data except for ALL NOTE OFF (CH1 – CH16).

** An error is generated if no data is received within 300 ms after reception of an active sensing byte (\$FE). In this case transmission will be interrupted for approximately 0.5 seconds.

** If the appropriate number of data bytes is not received, the received data or status bytes will not be transmitted (no echo back).

** Unrecognized status and data bytes will not be transmitted (no echo back).

Function...	Transmitted	Recognized	Remarks
Basic Default Channel Changed	1 - 16 * 1 - 16	all channel x	* memorized
Mode Default Messages	x	x OMNion, OMNIoff POLY, MONO	
Note Number : True voice	x *****	0 - 127	
Velocity Note ON Note OFF	x x	○ ○	
After Key's Touch Ch's	x x	○ ○	
Pitch Bender	x	○	
Control Change 0 - 121	○	○	
Prog Change : True #	○ 0 - 127 *****	○ 0 - 127	
System Exclusive	x	○	all
System : Song Pos : Song Sel Common : Tune	x x x	○ ○ ○	
System : Clock Real Time : Commands	x ○	○ ○	
Aux : Local ON/OFF : All Notes OFF Mes- : Active Sense sages : Reset	○ x ○ x	○ x ○ ○	
Notes	Received messages from MIDI IN are only bypassed to MIDI OUT.		

MODE 1 : OMNI ON, POLY
MODE 3 : OMNI OFF, POLY
15

MODE 2 : OMNI ON, MONO
MODE 4 : OMNI OFF, MONO

○ : Yes
x : No

RECEIVE DATA FOR YAMAHA MIDI EQUIPMENTS

MESSAGE	STATUS	2nd BYTE	SPX90	REV7	DX1	DX5	DX7	DX9	DX21	DX27	DX27S	DX100	QX5	QX21	RX11	RX15	RX21/ RX21L
Modulation wheel		01H (=1)	X	X	L	L	L	L	L	L	L	L	L	L	X	X	X
Breath control		02H (=2)	X	X	L	L	L	L	L	L	L	L	L	L	X	X	X
Foot control		04H (=4)	X	X	L	L	L	X	X	X	X	X	L	L	X	X	X
Portamento time		05H (=5)	X	X	L	L	L	L	L	L	L	L	L	L	X	X	X
Data entry slider		06H (=6)	X	X	L	L	L	L	X	X	X	X	L	L	L	X	X
Volume		07H (=7)	X	X	L	L	L	X	L	L	L	L	L	L	X	X	X
Sustain footswitch		40H (=64)	X	X	L	L	L	L	L	L	L	L	L	L	X	X	X
Portamento footswitch	BnH	41H (=65)	X	X	L	L	L	L	L	L	L	L	L	L	X	X	X
Data entry +1		60H (=96)	X	X	L	L	L	X	X	X	X	X	L	L	X	X	X
Data entry -1		61H (=97)	X	X	L	L	L	L	X	X	X	X	L	L	X	X	X
Local control ON/OFF		7AH (=122)	X	X	X	X	X	X	X	X	X	X	L	L	X	X	X
OMNI mode OFF		7CH (=124)	X	X	L	L	X	X	X	X	X	X	L	L	X	X	X
OMNI mode ON		7DH (=125)	X	X	L	L	X	X	X	X	X	X	L	L	X	X	X
MONO mode ON		7EH (=126)	X	X	L	L	L	L	L	L	L	L	L	L	X	X	X
POLY mode ON		7FH (=127)	X	X	L	L	L	L	L	L	L	L	L	L	X	X	X
Program change	CnH	Abbreviation	L	L	L	L	L	L	L	L	L	L	L	L	X	X	X
Start	FAH		X	X	X	X	X	X	X	X	X	X	L	L	L	L	L
Continue	FBH		X	X	X	X	X	X	X	X	X	X	L	L	L	L	L
Stop	FCH		X	X	X	X	X	X	X	X	X	X	L	L	L	L	L

L: receivable
X: not receivable

PROGRAM TABLE

MFC1 PROGRAM TABLE

DATE : _____

PROGRAMMER : _____

MIDI T. CH. : _____

● MEMORY MODE

BANK A			
1	2	3	4

BANK B			
1	2	3	4

FOOT CTRL	FOOT SW

● CHAIN MODE

BANK A 1

BANK A 1

BANK A 2

BANK A 2

BANK B 1

BANK B 1

BANK B 2

BANK B 2

SINCE 1887  **YAMAHA**
NIPPON GAKKI CO., LTD. HAMAMATSU, JAPAN