

TOOL

THE OFFICIAL PUBLICATION OF THE YAMAHA USERS GROUP

DX11 System



AUGUST 1988

 YAMAHA®

News & Information

Welcome to a new After-Touch feature. Each month, this column will provide readers with information on new products and services being offered by Yamaha in support of their digital instrument product line.

Special Edition ROM For The Original DX7

A Special Edition System ROM (part number SER-7) has been developed to enhance the Performance and MIDI capabilities of the original DX7. The new features provided by this ROM include: 1) MIDI Transmit, which allows the DX7 to transmit on any of the 16 MIDI channels; 2) Full Function Memory, which allows function parameters to be memorized for each voice; 3) Main Volume Transmit, which allows the user to transmit MIDI Volume data using the Modulation Foot Controller Input (this parameter can be memorized for each voice); 4) MIDI Channel Information On/Off, which can enable or disable Program Changes and Control Changes; 5) Aftertouch On/Off, which selects whether or not aftertouch data is transmitted (this parameter can be memorized for each voice); 6) Master Tune Display, which shows the current Master Tune setting; 7) Function Initialization, which allows initialization of function parameters for a single voice or for all 32 voices; and 8) MIDI Receive, which allows the DX7 to receive MIDI data in OMNI mode, or on any of the 16 MIDI channels.

The Special Edition ROM comes with an extensive Instruction Guide that explains all installation and operational procedures. The suggested retail price is \$75.00. For more details, call the Yamaha Electronic Service Parts Department: 1-800-443-3548.

Backlit LCD Display For The Original DX7

This new LCD display for the original DX7 (part number LCD-7) is a 2-row (16 character per row), backlit LCD. It allows musicians to read the information on the DX7 LCD in situations with dim lighting.

The Backlit LCD's suggested retail price is \$75.00. There is also a special package price

available with an order of both the Special Edition ROM and the Backlit LCD; the combination is available for a suggested retail price of \$100.00. For more details, call the Yamaha Electronic Service Parts Department: 1-800-443-3548.

Replacement Control Panel For The Original DX7

If the front panel on your original DX7 is cracked, damaged, or just plain worn out, the Replacement Control Panel Overlay (part number CX800540) is available. The suggested retail price is \$32.00. For more details, call the Yamaha Electronic Service Parts Department: 1-800-443-3548.

New TX16W Voice Library

Yamaha has just released the London R&D Library for the TX16W stereo digital wave filtering sampler. These new samples were created and compiled by the Yamaha London Research & Development facility. Two complete 12-disk sets are available, each packaged in its own binder/disk-holder (with complete documentation).

The first set, called the "Orchestral Collection," contains samples of flutes, oboes, panpipes, trumpets, trombones, french horns, clarinets, soprano saxophones, tenor saxophones, violins, violas, basses, and more. There are also a number of performances, which combine these sounds for useful layered sounds and splits. Of special interest is the fact that all of these sounds were sampled in the same acoustic "space," thereby making it very easy to blend them properly when creating ensembles.

The second set, entitled "Rock Collection," contains samples of various acoustic and electric guitars, drums, percussion, organs, basses, synthesizers, choirs, saxophones, and pianos. Each disk contains a well-balanced collection of instruments, for sequencing flexibility. There is also a two-disk set of drums and percussion, which turns the TX16W into a very capable drum tone generator.

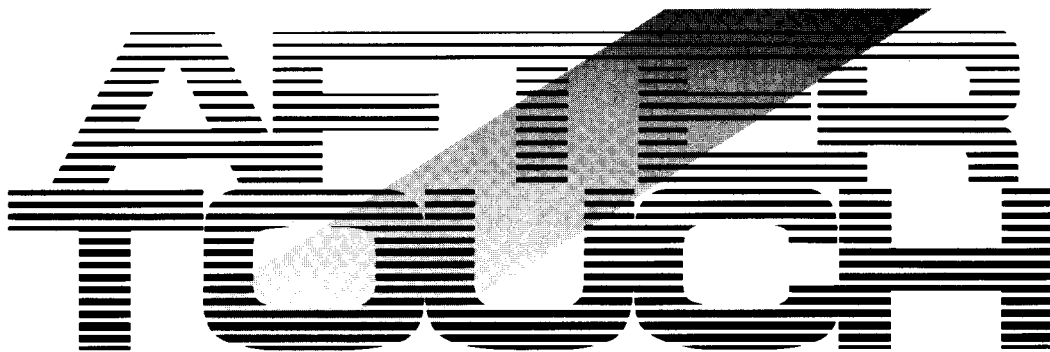

August 1988

Volume 4, Number 8
Issue #35

4 BABY/GRAND

A new DX100 voice created by Scott Watkins.

5 BONGO/BELL

A new DX100 voice created by Scott Watkins.

6 SOUND TRAK

A new DX100 voice created by Joe Cranford.

7 HARPYCHO

A new DX100 voice created by Richard Amador.

8 TX81Z

"StringHorn" and "Knock Bass," two new TX81Z voices by Dean Keith.

9 TX81Z

"Spectrum," a new TX81Z voice by Sylvia Pengilly.

9 TX81Z

"Mallense," a new TX81Z voice by Roland Steele.

10 DX11 System

An introduction to Yamaha's new component-style MIDI system.

13 C1 Music Computer

Part two of a detailed introduction to Yamaha's new music computer. By Michael A. Huisman.

16 MEP4/QX1

Using the MEP4 as a programming aid for the QX1.
By Paul J. Kurtz.

18 Questions

Answers to questions from readers.

Editor
Tom Darter

Operations
Sibyl Darter

Editorial Board
Charles Feilding
Bob Frye
Rick Huyett
Mark Koenig
J.P. Lincoln
Phil Moon
Jim Smerdel
Steve Thatcher

Cover Photograph
Jim Hagopian
Dee Dee Cawley

AFTERTOUCHE is published monthly. Third class postage paid at Long Prairie, MN and additional points of entry.
SUBSCRIPTIONS: Free. Address subscription correspondence to AFTERTOUCHE, P.O. Box 7938, Northridge, CA 91327-7938. **POSTMASTER:** Send form 3579 to P.O. Box 7938, Northridge, CA 91327-7938.

DX100

BABY/
GRAND. A
New DX100
Voice By
Scott Watkins.

LFO & FUNCTIONS					
TRI	35	0	0	0	OFF
WAVE	SPEED	DELAY	PMD	AMD	SYNC
0	0	C2			
PMS	AMS	KEY TRANSPOSE			
POLY	2	OFF	0		✓
POLY/MONO	PB RANGE	MODE	TIME	PORT	SUSTAIN
PORTAMENTO			FOOTSWITCH		
50	0	0	0	0	0
PITCH	AMPL	PITCH	AMPL	PITCH BIAS	EG BIAS
WHEEL RANGE		BREATH RANGE			

FREQUENCY	DETUNE	AMS		
5.00	+2	0		
ENVELOPE DATA				
AR	DIR	D1L	D2R	RR
19	1	12	1	4
EG BIAS	KEYBOARD SCALING			
0	RATE	LEVEL		
	3	99		
OP#	OUTPUT LEVEL	VELOCITY		
3	81	4		

FREQUENCY	DETUNE	AMS		
1.00	-3	0		
ENVELOPE DATA				
AR	DIR	D1L	D2R	RR
19	0	12	1	4
EG BIAS	KEYBOARD SCALING			
0	RATE	LEVEL		
	2	99		
OP#	OUTPUT LEVEL	VELOCITY		
2	81	1		

FREQUENCY	DETUNE	AMS		
25.95	+3	0		
ENVELOPE DATA				
AR	DIR	D1L	D2R	RR
19	1	12	1	4
EG BIAS	KEYBOARD SCALING			
0	RATE	LEVEL		
	3	99		
OP#	OUTPUT LEVEL	VELOCITY		
4	41	3		

FEEDBACK
LEVEL
7

FREQUENCY	DETUNE	AMS		
1.00	0	0		
ENVELOPE DATA				
AR	DIR	D1L	D2R	RR
19	2	12	1	4
EG BIAS	KEYBOARD SCALING			
0	RATE	LEVEL		
	3	0		
OP#	OUTPUT LEVEL	VELOCITY		
1	99	0		

ALGORITHM #3

Notes:

Here is THE piano sound all of you DX100 owners have been looking for.

DX100

**BONGO/
BELL. A New
DX100 Voice
By Scott
Watkins.**

LFO & FUNCTIONS					
TRI	35	0	0	0	OFF
WAVE	SPEED	DELAY	PWD	AMD	SYNC
0		0		C2	
PMS		AMS		KEY TRANSPOSE	
POLY	2	OFF	0		√
POLY/MONO	PB RANGE	MODE	TIME	PORT	SUSTAIN
PORTAMENTO			FOOTSWITCH		
0	0	0	0	0	0
PITCH		AMPL		PITCH BIAS	
WHEEL RANGE		BREATH RANGE			

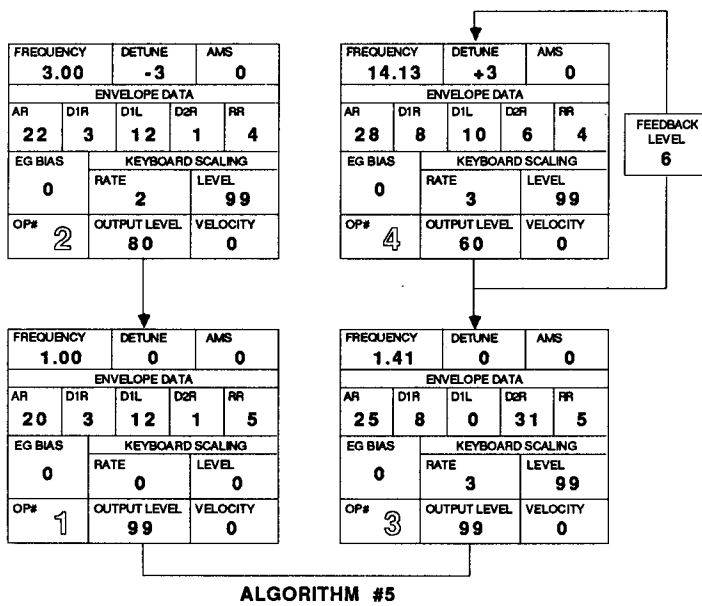

Notes:

This patch is great for percussive or rhythmic chord playing.

DX100

SOUND TRAK. A New DX100 Voice
By Joe Cranford.

LFO & FUNCTIONS					
TRI	33	30	42	0	OFF
WAVE	SPEED	DELAY	PMD	AMD	SYNC
4		0		C1	
PMS		AMS		KEY TRANSPOSE	
POLY	5	OFF	0		√
POLY/MONO	PB RANGE	MODE	TIME	PORT	SUSTAIN
PORTAMENTO			FOOTSWITCH		
50	0	50	0	50	0
PITCH	AMPL	PITCH	AMPL	PITCH BIAS	EG BIAS
WHEEL RANGE			BREATH RANGE		

FREQUENCY	4.00	DETUNE	0	AMS	0
ENVELOPE DATA					
AR	D1R	D1L	D2R	RR	
7	31	15	0	3	
EG BIAS	KEYBOARD SCALING				
0	RATE	LEVEL			
	1	46			
OP#	OUTPUT LEVEL	VELOCITY			
3	67	0			

FREQUENCY	6.00	DETUNE	-3	AMS	0
ENVELOPE DATA					
AR	D1R	D1L	D2R	RR	
7	31	15	0	3	
EG BIAS	KEYBOARD SCALING				
0	RATE	LEVEL			
	1	35			
OP#	OUTPUT LEVEL	VELOCITY			
2	59	0			

FREQUENCY	2.00	DETUNE	+3	AMS	0
ENVELOPE DATA					
AR	D1R	D1L	D2R	RR	
7	31	15	0	3	
EG BIAS	KEYBOARD SCALING				
0	RATE	LEVEL			
	1	21			
OP#	OUTPUT LEVEL	VELOCITY			
4	65	0			

FEEDBACK LEVEL
7

FREQUENCY	4.00	DETUNE	0	AMS	0
ENVELOPE DATA					
AR	D1R	D1L	D2R	RR	
7	31	15	0	3	
EG BIAS	KEYBOARD SCALING				
0	RATE	LEVEL			
	1	0			
OP#	OUTPUT LEVEL	VELOCITY			
1	92	0			

ALGORITHM #3

Notes:

Also, try this patch with a frequency of 8.00 on Op. #4, and with faster attack and release rates. Don't wait for the movie!

DX100

HARPYCHO.
A New DX100
Voice By
Richard
Amador.

LFO & FUNCTIONS					
TRI	28	14	78	0	ON
WAVE	SPEED	DELAY	FWD	AMD	SYNC
1		3		F#1	
FMS		AMS		KEY TRANSPOSE	
POLY	4	OFF	0		✓
POLY/MONO	PB RANGE	MODE	TIME	PORT	SUSTAIN
PORTAMENTO			FOOTSWITCH		
50	0	0	0	50	0
PITCH	AMPL	PITCH	AMPL	PITCH BIAS	EG BIAS
WHEEL RANGE			BREATH RANGE		

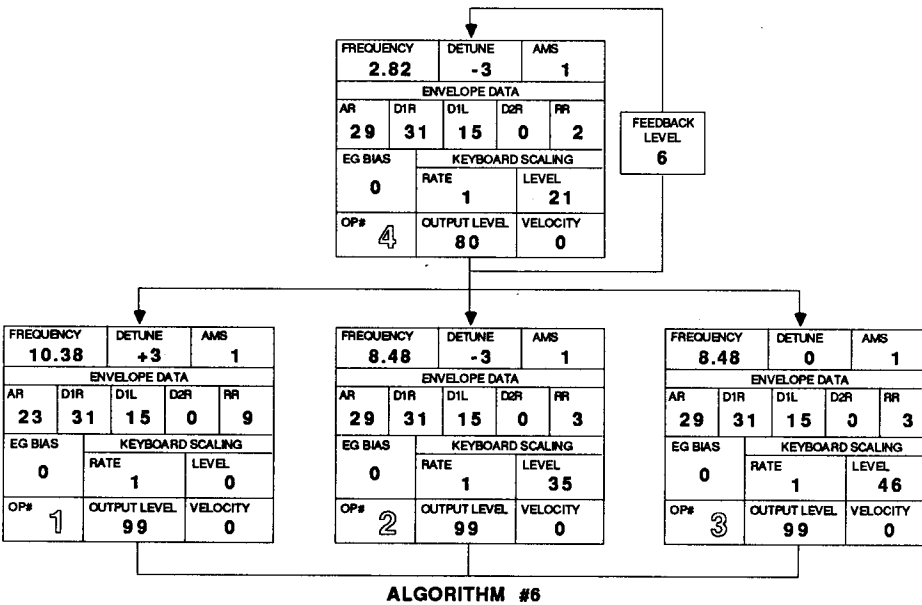

Notes:

This patch is designed for musicians who need a highly-reverberated, electronic music sound. It is superb as a lead instrument voice.

If played staccato, the patch gives a strong electric harp effect, complete with complex harmonics (provided by Op. #1) to simulate an amplified pluck. If you want to sustain notes, however, these complex harmonics may not be to your liking. To make the overall sound more mellow for sustained notes, change the Frequency Ratio of Op. #1 to 11.30, or simply turn Op. #1 off by setting its Output Level to 0.

TX81Z

StringHorn and Knock Bass. Two New TX81Z Voices By Dean Keith.

Notes:

To save programming time, start from the DoubleBass preset (B17).

Notes:

This bass voice is very useful when you want each note of a bass line to stand out. Try layering it with other bass patches.

OPERATOR	op1	op2	op3	op4
on/off	ON	ON	ON	ON
out level	99	86	71	78
freq. type	RTO	RTO	RTO	RTO
fix range	255	255	255	255
freq. coarse	4	10	27	4
freq. fine	0	0	3	0
detune	+0	-3	+3	+0
-1-	-2-	-3-	-4-	
1.00	3.00	8.97	1.00	

ENVELOPE	op1	op2	op3	op4
attack rate	18	13	13	13
decay 1 rate	10	5	7	2
decay 1 level	15	14	9	14
decay 2 rate	0	0	0	0
release rate	5	6	6	4
eg shift	OFF	OFF	OFF	OFF

SCALING/SENS	op1	op2	op3	op4
rate	1	1	1	0
level	0	99	99	99
ams on/off	OFF	OFF	OFF	OFF
sens eg bias	0	0	0	0
key vel	1	1	2	0

voice name: StringHorn

algorithm no. 3

feedback 6

LFO

waveform		sync	OFF
speed	26	delay	8
amp mod depth	0	sens	0
pitch mod depth	13	sens	5

FUNCTION

mode	POLY	mid C =	C 2
portamento	FULL	rev rate	5
porta time	0	pb range	4
vol	99	pitch	0
pitch	0	amp	0
amp	0	eg bias	0
pitch	50	p bias	+0
amp	0		

OPERATOR	op1	op2	op3	op4
on/off	ON	ON	ON	ON
out level	99	74	71	79
freq. type	RTO	RTO	RTO	RTO
fix range	255	255	255	255
freq. coarse	0	0	31	4
freq. fine	0	0	0	0
detune	-3	+0	+0	+3
-1-	-2-	-3-	-4-	
0.50	0.50	10.00	1.00	

ENVELOPE	op1	op2	op3	op4
attack rate	31	31	31	31
decay 1 rate	9	9	17	16
decay 1 level	0	0	0	3
decay 2 rate	0	0	0	7
release rate	8	8	8	8
eg shift	OFF	OFF	OFF	OFF

SCALING/SENS	op1	op2	op3	op4
rate	1	1	1	0
level	0	0	0	0
ams on/off	OFF	OFF	OFF	OFF
sens eg bias	0	0	0	0
key vel	1	1	1	3

voice name: Knock Bass

algorithm no. 4

feedback 7

LFO

waveform		sync	OFF
speed	33	delay	0
amp mod depth	0	sens	0
pitch mod depth	7	sens	5

FUNCTION

mode	POLY	mid C =	C 2
portamento	FULL	rev rate	0
porta time	0	pb range	2
vol	99	pitch	50
pitch	0	amp	0
amp	0	eg bias	0
pitch	50	p bias	+0
amp	0		

TX81Z

Spectrum. A New TX81Z Voice By Sylvia Pengilly.

OPERATOR	op1	op2	op3	op4
on/off	ON	ON	ON	ON
out level	99	99	0	0
freq. type	RTO	RTO	RTO	RTO
fix range	255	255	255	255
freq. coarse	2	3	4	4
freq. fine	2	0	0	0
detune	-3	-3	+0	+0
<hr/>				
-1-	-2-	-3-	-4-	
0.98	0.87	1.00	1.00	

ENVELOPE	op1	op2	op3	op4
attack rate	2	2	31	31
decay 1 rate	31	31	31	31
decay 1 level	15	15	15	15
decay 2 rate	1	1	0	0
release rate	2	2	15	15
eg shift	OFF	OFF	OFF	OFF

SCALING/SENS	op1	op2	op3	op4
rate	1	0	0	0
level	0	0	0	0
ams on/off	ON	ON	OFF	OFF
sens eg bias	0	0	0	0
key vel	0	0	0	0

voice name: Spectrum

algorithm no. 1
feedback 0

LFO	op1	op2	op3	op4
waveform				
speed	32	32	32	32
amp mod depth	0	0	0	0
pitch mod depth	3	3	3	3
sync	OFF	OFF	OFF	OFF
delay	0	0	0	0

FUNCTION	op1	op2	op3	op4
mode	POLY	POLY	POLY	POLY
mid C =	C	C	C	C
portamento	FULL	FULL	FULL	FULL
porta time	0	0	0	0
pb range	4	4	4	4
vol	99	99	99	99
pitch	0	0	0	0
amp	0	0	0	0
pitch	50	50	50	50
amp	50	50	50	50
pitch	0	0	0	0
rev rate	0	0	0	0
eg bias	0	0	0	0
p bias	+0	+0	+0	+0

Notes:

As the name implies, this patch swings up through the harmonic spectrum. Although it uses only two operators (Op. #1, and Op. #2), it really packs quite a punch! Hold the key down for about five seconds to allow the patch to complete its long envelope.

Mallense. A New TX81Z Voice By Roland Steele.

OPERATOR	op1	op2	op3	op4
on/off	ON	ON	ON	ON
out level	99	75	93	85
freq. type	RTO	RTO	RTO	RTO
fix range	255	255	255	255
freq. coarse	4	10	9	19
freq. fine	8	0	2	0
detune	+0	-3	+3	-2
<hr/>				
-1-	-2-	-3-	-4-	
1.50	3.00	2.99	6.00	

ENVELOPE	op1	op2	op3	op4
attack rate	16	31	31	31
decay 1 rate	8	25	20	23
decay 1 level	14	13	11	13
decay 2 rate	0	0	9	17
release rate	6	1	9	10
eg shift	OFF	OFF	OFF	OFF

SCALING/SENS	op1	op2	op3	op4
rate	1	0	0	1
level	0	0	0	0
ams on/off	ON	ON	OFF	OFF
sens eg bias	0	3	0	0
key vel	2	2	2	2

voice name: Mallense

algorithm no. 5
feedback 0

LFO	op1	op2	op3	op4
waveform				
speed	30	30	30	30
amp mod depth	0	0	0	0
pitch mod depth	11	11	11	11
sync	ON	ON	ON	ON
delay	4	4	4	4

FUNCTION	op1	op2	op3	op4
mode	POLY	POLY	POLY	POLY
mid C =	F	F	F	F
portamento	FULL	FULL	FULL	FULL
porta time	0	0	0	0
pb range	2	2	2	2
vol	99	99	99	99
pitch	0	0	0	0
amp	0	0	0	0
pitch	50	50	50	50
amp	0	0	0	0
pitch	0	0	0	0
rev rate	0	0	0	0
eg bias	0	0	0	0
p bias	+0	+0	+0	+0

Notes:

This is a "mallet ensemble" patch: as a solo voice, the timbres of flute, violin, and soft mallet are all evident, and it takes very well to jazz improvisation. Polyphonically, it produces very smooth accompanying chords.

DX11 System

An Introduction To Yamaha's New Component-Style MIDI System.

THE MIDI REVOLUTION has opened up a number of exciting possibilities for musicians; at the same time, however, it has created an entirely new set of terms and disciplines for musicians to learn. To help the MIDI education process, Yamaha has designed the DX11 System, a MIDI setup that offers a great deal of flexibility without a lot of complexity.

Each part of the DX11 MIDI System is important. The QX21 digital sequence recorder functions as both a MIDI recorder and a MIDI playback unit. The DX11 FM digital synthesizer functions as both a multi-timbral tone generator and a MIDI input keyboard for the sequencer. The RX120 digital rhythm programmer adds the percussion dimension to the system. The KM602 mixer provides control over the sonic output from the DX11 and RX120. The REX50 digital multi effector offers a multitude of preset and programmable effects. Finally, the KS10 powered monitor speakers function as both amplifier and monitor speakers for the stereo outputs of the KM602.

Here is a quick overview of the various units that combine to form the DX11 MIDI System:

DX11 FM Digital Synthesizer

The DX11 is Yamaha's first fully multi-timbral keyboard synthesizer. It combines all of the features of the popular TX81Z FM digital tone generator with a 61-note, velocity-sensitive, aftertouch-equipped keyboard. Also, like most Yamaha keyboard synthesizers, the DX11 has both a Pitch Bend wheel and a Modulation wheel, plus jacks that allow connection of a Breath Controller, a Foot Controller, a Footswitch, and a volume pedal.

Like the TX81Z, the DX11 has a 4-operator, 8-algorithm FM voice architecture. In addition, the TX81Z and DX11 are the only Yamaha FM digital synthesizers that offer waveforms other than sine waves. Both give you a choice of eight different waveforms, offering a greater richness of timbre than ever before available in a 4-operator unit.

Since the DX11 has a full set of front panel controls, all editing and utility features are much easier to access than they are on the rack-mount TX81Z. In addition, the DX11 offers new parameters, new editing features, and expanded memory options.

For novice programmers, the DX11 has a Quick Edit section, which allows you to make

fast adjustments in the overall sound of a voice. There are four basic parameters: Attack, Release, Volume, and Brilliance. *Attack* and *Release* adjust the Attack Rate, Decay 1 Rate, and Release rate of all operators equally. *Volume* adjusts the Output Level of all carriers. *Brilliance* adjusts the Output Level and Decay 1 Rate of all modulators.

For more information on the DX11, see the introductory article in the February 1988 issue of *AfterTouch*.

QX21 Digital Sequence Recorder

A digital sequence recorder is an instrument that stores digital information received via MIDI for later playback through one or more MIDI-controllable synthesizers, tone generators, or drum machines. Information in the QX21 is stored as digital data, representing a series of MIDI-transmitted events. These events include Note On data (with or without velocity information), Note Off data, Controller Change data (involving controllers such as the pitch bend wheel), or Program Change data.

Most of the QX21's operations are carried out using one of the instrument's many "Job" functions. These are separated into four groups: A, B, C, and D. All of these Job functions are described in the QX21 owners manual, and are outlined in the diagram printed on top of the instrument. You can step through Job function set A using the JOB STEP A/C button, and you can step through set B using the JOB STEP B/D button. Job function sets C and D are accessed by holding RESET and pressing the A/C or B/D buttons.

Let's take a close look at the basic recording layout of the QX21, because the terminology can be confusing. First of all, there are two "tracks" on the QX21. These are simply memory locations for MIDI data, and operate very differently than the tracks of a tape recorder. Since a single MIDI "track" can contain information that encompasses all 16 MIDI channels, it is quite possible for one "track" of the QX21 to control sixteen different instruments, each playing different music.

All recording on the QX21 goes onto TRACK 1. This is the only live recording track. TRACK 2 is the storage track, and information from a first recording pass must be moved to TRACK 2 if you wish to overdub. If you Record again on TRACK 1 before moving the first take



RX120 digital rhythm programmer.

to TRACK 2, the original information will be erased and replaced by the new recording.

So, in Record mode, MIDI information received is recorded onto TRACK 1. This data on TRACK 1 can be moved to TRACK 2 by means of EXCHANGE (Job B-1), which exchanges the data on TRACK 1 with the data on TRACK 2. This is used most often after the very first recording to exchange the newly recorded material on TRACK 1 with the blank TRACK 2, prior to recording the first overdub.

To record the first overdub, pick a new MIDI record channel (if desired), set TRACK 2 for playback, and go into RECORD mode again. You will then record on TRACK 1 while listening to the material already in TRACK 2.

After you have material on both TRACK 1 and TRACK 2, there are a number of useful Job functions that allow you to combine the information in various ways.

Remember that multiple channels of MIDI data can be stored on a single QX21 TRACK, with MIDI channel integrity maintained for each. For example, an instrument part can be recorded via MIDI channel 1 on TRACK 1, and exchanged (Job B-1) to TRACK 2; then a second instrument part can be recorded on the now blank TRACK 1 via MIDI channel 2. If you are happy with both takes, you can track down (Job B-3) the new material to TRACK 2. This process can be repeated to create up to 16 separate parts on 16 MIDI channels.

The QX21 operates in much the same manner as its older brother, the QX7. For more information on the operation of the QX7, see the 7 System article in the November 1985 issue of *AfterTouch*.

RX120 Digital Rhythm Programmer

Yamaha's new RX120 digital rhythm programmer takes a different approach to the creation of electronic drum and percussion parts. It is designed for musicians who want an inexpensive drum machine that comes complete with a large repertoire of preset patterns, covering a wide range of musical styles. Instead of requiring the musician to create each stylistic pattern before beginning the creation of a song structure, the RX120 provides a wide variety of preset patterns, which can be combined into a number of programmable song structures.

As with all electronic musical devices designed for a specific purpose, the RX120 embodies a number of carefully-chosen trade-offs: On the one hand, it is not possible to program basic rhythm patterns into the unit; on the other hand, it is not necessary to spend time programming basic rhythm patterns into the unit—this basic work has already been done.

The RX120 comes equipped with a full complement of 38 sampled percussive sounds, including acoustic and electronic drum sounds, percussion instruments, sounds effects, and two

DX11 System *Continued*

FM percussion voices.

The unit also contains 40 preset drum patterns in permanent (ROM) memory. This is not the complete story, though: Each one of these preset patterns features three basic variations, plus two fill-ins, one break, one intro, and one ending, for a total of eight ways to play each preset. Given all of these options, the unit actually contains a total of 320 preset patterns.

Since patterns are not programmable, the unit's front panel does not have instrument keys; instead, it has *pattern* keys. There is a front-panel key for each one of the forty basic patterns, plus other keys to call up each one of the various pattern options.

In addition to the 40 preset patterns in memory, the RX120 also contains 20 memory locations to program and store your songs. Each song memory can be up to 500 bars long, and can therefore contain 500 different pattern designations.

For more information on the RX120, see the introductory article in the April 1988 issue of *AfterTouch*.

KM602 Mixer

The KM602 is a compact, 6-in, 2-out mixer designed with the needs of keyboard players in mind. It features a stereo effects return and a built-in chorus effect. It also has a stereo headphone monitor jack with a volume control that

is independent from the main output. The unit's highly-visible faders make it easy to use, even on dimly-lit stages.

REX50 Digital Multi Effector

The REX50 is a versatile multi-effects unit in a compact package. It offers a selection of 30 top-quality preset effects, including digital reverb, gated reverb, echo, flange, phase-shift, and a group of distortion effects. These distortion effects actually combine distortion with other effects (such as reverb, flange, and so on) for extraordinary sound processing versatility.

In addition, there are 60 "user memory" locations, which can be used to store edited versions of the 30 preset effect programs. The REX50 is also MIDI compatible, which means that you can select specific effects via MIDI. The back panel features both stereo inputs and stereo outputs.

KS10 Powered Monitor Speakers

The KS10 powered monitor speaker is designed specifically for use in keyboard systems; its size (smaller than a bread box) and weight (4 pounds) make it an ideal monitor speaker for setups like the DX11 System.

Each KS10 features a 4-inch, full-range, Mylar/Polymer speaker for clear sound reproduction. Volume and Low Boost controls are mounted on the front of the speaker enclosure for your convenience. The frequency response of the KS10 speaker is 20Hz to 20kHz. The Low Boost control boosts low frequencies to a maximum of 11db, with a peak of 100Hz.

A built-in amplifier provides 6.5 watts of output power. Since the KS10s are powered speakers, the DX11 System does not need an external amplifier. The input connector on the back is a standard 1/4" phone jack, making it easy to connect the KS10s to the outputs of the KM602. Two KS10 speakers give the DX11 System full stereo capability.

. . . .

As you can see, the DX11 System is a very flexible music-making tool. The package comes complete with its own manual, which provides simple, step-by-step instructions for setting up and using the DX11 system to create music using the exciting new vistas provided by the MIDI revolution.

KS10 powered monitor speakers.

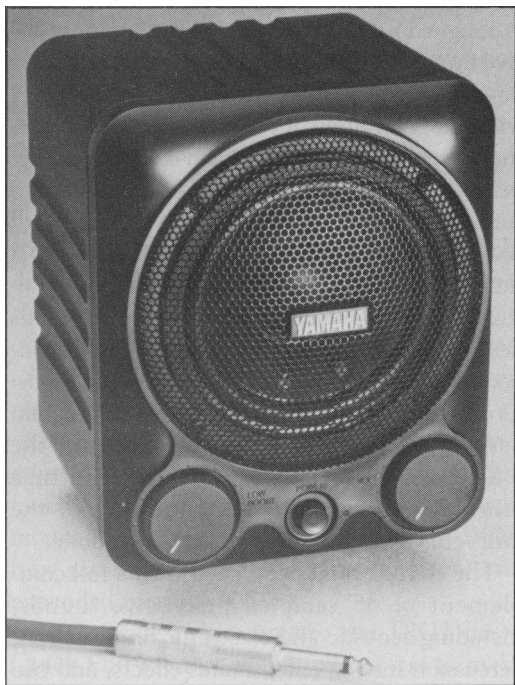

C1 Music Computer

DURING OUR PREVIOUS VISIT on these pages, we introduced Yamaha's new C1 music computer. For those of you reading this second installment without knowledge of the first segment, here is a summary of the C1's main features:

- It is a portable computer that utilizes Intel's 80286 microprocessor.
- It is full IBM PC/AT compatible.
- It's processor can run at switchable speeds of 8 or 10 megaHertz.
- An optional math-coprocessor, the 80287, is available.
- The unit is equipped (standard) with 640 Kbytes of main memory and 512 Kbytes of extended memory.
- The keyboard is ASCII standard, and also features a ten-key numeric pad.
- There are 10 function keys and cursor-movement keys.
- The front panel also includes two sliders, named in the Yamaha MIDI standard as CS1 and CS2.
- The unit features a backlit, supertwist LCD display with 640 x 400 resolution; brightness and contrast controls are included.
- There is a custom MIDI chip for handling MIDI communications.
- There is a separate timer for applications.
- The bank panel features two MIDI INputs, a MIDI THRUput, and *eight* MIDI OUTputs!
- A SMPTE reader/generator is built in.
- The unit includes ports for connecting a printer (via a parallel Centronics interface).
- There are two serial ports for connecting a modem and mouse or other serial device.
- There is also an expansion port that allows the use of Toshiba-compatible expansion devices.

At this point, I'd highly recommend that, if you have not read the first article on this subject and want to know more about the C1's basic architecture, you obtain a copy of last month's issue (July '88): The first part of this introductory article contained a lot of detailed information about specific features of the C1. Now, to continue:

Everything's Gone Digital; or, "Who Is Really In There?"

Computers are everywhere in music today. There have probably been only one or two synthesizers made in this decade that are not primarily under the control of a microprocessor. Today's digital instruments are truly computers, specifically designed and evolved for the purpose of creating sound. The inclusion of disk drives, a mouse, external video monitors, and ten-key pads are visible clues to the true identity of the mind of these instruments. Engineers have tried to minimize the impact of these clues, because there are many musicians who want to feel that they are playing an instrument, not a computer. The fact still remains, however, that our current instruments *are* computers.

A sequencer's true identity as a computer is very thinly veiled, because a sequencer makes no sound of its own, save for the mechanical sound of its metronome.

So, what price do we pay for *hiding* the computers in our musical instruments? First of all, we compromise the interface by which we communicate with the computer. By this what I mean is that, many times, how we instruct the instrument's computer to manipulate data is not exactly comfortable.

We reduce the size of the computer's potential display drastically (just for reference, a typical computer display can show 80 characters on a single line across the screen, with more than twenty lines of text horizontally). We also severely limit the computer's ability to show relationships between values graphically.

How important are graphics? Well, we've all heard the phrase, "a picture is worth a thousand words" before, and music notation is a graphics-oriented alphabet.

We also remove the computer's keyboard (we're talking about a typewriter keyboard here) and replace it with just a few data entry keys.

Improving Your Peripheral Vision With the C1

It is very difficult to see related values in the displays that are designed into digital musical instrument products. For example, to edit the values for operator envelope and level scaling for a single operator on the original DX7, you

**A Detailed Introduction To Yamaha's New Music Computer, Part 2.
By Michael A. Huisman.**

C1 Music Computer *Continued*

would have to look at as many as thirteen different displays just to see what was going on. With the DX7 II series and its improved, larger display, those thirteen displays are reduced to just two; much better. The problem reappears, however, when we consider that a single operator rarely works by itself. The interaction of different operators is the key to FM voice programming, and once we consider that a single voice may have up to six operators, we find that the number of displays we have to look at has just risen by a factor of six. If you use the DX7 II's dual voice play mode, there are twelve operators to deal with.

The large display used on the C1 can display many more times the data than can be displayed on a normal synthesizer LCD. In fact, it is possible to display *all* of the parameters of a single DX7-style voice on just one C1 display screen. The programming of synthesizer voices is much easier when you can see all the parameters of a sound at once.

And what about sequencing? In a normal dedicated hardware sequencer, we can usually see one note at a time. So you want to see a chord all at once? Highly unlikely. With the C1, you can see several "two-fisted" chords worth of data at once without any difficulty at all.

Okay, so now you're probably saying, "Yeah, but who wants to lug a TV set with them to a gig?" Therein lies the true beauty of the C1: Its high resolution display competes easily with the standard computer TV-sized displays, yet it is only slightly larger in size than a 45 RPM record. Also, the display screen acts as the C1's keyboard cover when not in use.

Consolidate Your Data

How many of us have more than one synthesizer? Many, if not most. Let's look at a simple setup, say an original DX7 and TX81Z. Let's say you have a dozen DX7 RAM cartridges (a sizable investment with no way to back up data) plus a cassette tape of sounds for your TX81Z. How would you like to save all of that data on a single computer disk (easily backed up) with plenty of room to spare? Yeah, thought so. Sounds like a really good idea.

If you have a large MIDI system, the savings and ease of maintenance benefits really add up in a big hurry.

Your Mother Always Told You To Share

In the old days, musicians/writers/arrangers were limited by the number of instruments available. They had to write good songs because the sounds were not the principal ingredient of a performance. Everyone had pretty much the same access to sounds, and the test was to see what you could do with the standard palette. Sounds a little scary today, right? Well, the good news is that we don't have to go back to those days. The advent of digital synthesizers has truly exploded the palette of sounds we have at our disposal, but some guys still seem to have more colors than others. Using a C1, especially one with a hard disk drive installed, a library of 20,000 sounds can be stored easily. Say you have a friend who also has a C1 with a few thousand sounds. If you decide to trade sounds with this friend using RAM cartridges, you might need to sign a year lease somewhere to sift through the sounds. Swapping a single disk takes just minutes, and the C1 can compare the sounds on the disk you have received from your friend and throw out the sounds you already have in your existing library.

So, if we all share the sounds we have with our friends and colleagues (remember, listen to your mother), we all benefit. Why? The challenge of writing and performing good music returns, because the available sound palette becomes equal, forcing you (us, really) to write better songs. Of course, even if you ignore your own mother and don't want to share, ten thousand sounds on RAM cartridges are not manageable, so do yourself a favor and get a C1.

Also, since the C1 is fully IBM PC/AT compatible, you can use a word processing program to, you know, send form letters to all of your favorite family members during those hectic holiday and birthday times. (Don't panic, this is just computer humor.)

Can We Talk?

Most musicians own and use instruments created by a number of different manufacturers. This is okay, and musical instrument manufacturers understand and accept this fact. Let's say you own a number of instruments representing a variety of manufacturers. Is there any reason why the C1 can't perform the same kind of functions (voicing, library management and sequencing) with another manufacturer's key-

boards as it does with Yamaha gear? No, none at all. Yamaha is actively utilizing third-party (*independent*) software developers for exactly this reason. The C1 can and should be your music computer, regardless of whose MIDI instruments you currently own and use. You should see software for the C1 supporting all manufacturer's instruments in the very near future. Watch these pages, and the advertisements in other keyboard music magazines for announcements and details.

Should I Be Using A Computer For Music?

This is a very good question, one that many musicians are asking themselves a lot lately. The introduction of a product such as the C1 adds more wood to that fire. Let's consider a couple of things:

- The C1 is a very powerful computer that has been carefully designed and packaged in such a way to be attractive to musicians. Its size, backlit high-resolution display, MIDI hardware, and SMPTE capabilities are all very useful attributes.
- Since the C1 is not dedicated to a specific musical function, it is much more than an electronic musical instrument—it is a general-purpose computer. If you need a new function, all you need to do is find a *software* solution to your problem. If you need more tracks for your sequencer applications, simply find a more powerful program. If you add a new synth or tone module to your setup, simply update your librarian to include the new instrument. And, if you want a word processor, all you need to do is buy a program for the C1 that suits your needs.

Also, since the C1 is a multi-function MIDI music device, it may reduce the need for certain hardware items, such as MIDI junction boxes and event processors.

The decision to use a computer for music is not an easy one for some. If you are one of these people, and there are many of you (so don't feel badly because some guy told you that you might be ignoring some huge new technological

advance), just relax. Talk to someone who uses a computer in their music rig. Find out how they feel about it, how they use it, and what they recommend. If you don't know anyone who fits that bill, ask your keyboard dealer.

Dealers are not there simply to sell you stuff and send you out the door. Your keyboard salesman can be a very valuable resource. He may know if someone is already doing what you are considering, and may be able to hook you up with someone who can give additional assistance if he can't. And, if you appreciate this help, you should reciprocate the dealer's good work by buying new products from him. It's always good to support dealers that provide these extra services.

Once you have considered all your needs and options, I'm sure you will find that the C1 music computer fits the bill quite comfortably.

The C1's Programmer Toolbox Routines

While we don't have enough room in this article to investigate the programmers toolbox fully, we can touch on a few things.

The programmers toolbox consists of pre-written, tested, and compiled routines that are available from Yamaha for a small licensing fee (this fee is used to offset the costs of production, such as printing and packaging). These routines can be used to manipulate the music-related hardware of the C1, such as the MIDI ports, the two data entry sliders, and the SMPTE reader/generator. There are low and high level driver routines for input/output buffer management, data management, and a ton of other functions. While these routines are of primary interest to third-party software developers, they are also very useful for home hobbyists who want to write their own specific MIDI programs. Contact Yamaha for details on how to license these routines.

. . . .

Well, guess what—we're out of space for this issue. For more information on the C1, look to these pages, and to the pages of your favorite keyboard magazines, because there is much more coming up on the horizon for the Yamaha C1 music computer.

MEP4/QX1

Using the MEP4 As A Programming Aid For The QX1. By Paul J. Kurtz.

THE MEP4 MIDI EVENT PROCESSOR is a wonderful piece of gear. It enables the user to take full advantage of the MIDI system by surmounting the limitations of equipment design or human operation. One application that I have found useful involves using the MEP4 as a programming aid for the QX1 digital sequence recorder. The QX1 is the grandfather of high-end dedicated sequencers; but, as with all types of electronic equipment, it has certain limitations. I have discovered a method by which I can use the MEP4 to overcome one of the few limitations of the QX1.

The majority of my work with the QX1 is done in Edit Mode, because it allows the programmer to be very precise in determining the information to be entered. Long musical phrases containing many note messages can be entered quite rapidly due to the design of the QX1. However, if I want to do any type of scaling, the process of entering this information can become quite cumbersome.

Scaling can be defined as a change in the value of a Continuous Controller (such as aftertouch, breath controller, modulation wheel, and so on) over a specific time period. In order to insure smooth operation, the QX1 manual suggests entering several Control changes at small intervals, each with slightly different values. In reality, however, I have found that, most of the time, it takes many more than several Control changes to guarantee smooth operation of the controllers.

For each Control change, five pieces of information must be entered. If you want to have the smoothest possible operation of a Controller from smallest value to largest value, you would have to enter up to 128 different Control changes (since the value of any Continuous Controller can be from 0 to 127). This means entering up to 640 pieces of information to obtain an effect that might last only a few seconds. It will sound great, but, as mentioned before, it is quite cumbersome and time consuming. This is where the MEP4 comes into play. Since I can enter Note messages very quickly on QX1, I can use the MEP4 to convert these Note messages into Continuous Controller messages, thereby ensuring smooth operation of the controllers with far less effort than before. It is now just a matter of programming the MEP4 correctly in order to achieve the desired result.

The MEP4 should be programmed as follows:

PROCESSOR 1

DATA PRESETTER

PROGRAM: OFF
PITCH: OFF
CONTROL 1: OFF
CONTROL 2: OFF

CHANNEL FILTER

OMNI: ON

MESSAGE FILTER

NOTE OFF: OFF
NOTE ON: ON
POLY A. TOUCH: OFF
CONTROL NO.: OFF
PROGRAM CHANGE: OFF
CH A. TOUCH: OFF
PITCH BEND: OFF
CH MODE MES.: OFF
SYSTEM MES.: OFF

DATA MODIFIER

0 MSG: 9n.xx.yy
1 LIM: yy,02≤D≤7F
2 CNV: → Bn.07.yy
3
4

DELAY PROCESSOR

DELAY TIME: 0

OUTPUT ASSIGNER

OUT-CH ASSIGN: 1
OUT-CH OFFSET: 0
OUTPORT ASSIGN: 1

PROCESSOR 2

DATA PRESETTER

PROGRAM: OFF
PITCH: OFF
CONTROL 1: OFF
CONTROL 2: OFF

CHANNEL FILTER

OMNI: ON

MESSAGE FILTER

NOTE OFF: OFF
NOTE ON: ON
POLY A. TOUCH: OFF
CONTROL NO.: OFF

PROGRAM CHANGE: OFF
CH A. TOUCH: OFF
PITCH BEND: OFF
CH MODE: MES.: OFF
SYSTEM MES.: OFF

DATA MODIFIER

0 MSG: 9n.xx.yy
1 LIM: yy, $01 \leq D \leq 01$
2 OFS: yy, v = -1
3 CNV: → Bn.07.yy
4

DELAY PROCESSOR

DELAY TIME: 0

OUTPUT ASSIGNER

OUT-CH ASSIGN: 1
OUT-CH OFFSET: 0
OUTPORT ASSIGN: 1

As you can see, Processors 1 and 2 are programmed identically except for the Data Modifier section; and, as the MEP4 manual states, this is where the real action takes place. Processors 3 and 4 can be turned off, since they are not used in this application.

The Data Modifier section of Processor 1 will look for any incoming Note-On messages; it will limit the Note-On messages to be modified to those that have a velocity value from 2 to 127; then, it will convert these messages to Continuous Controller 07 (Main Volume) messages, with the same values that the original Note-On messages had.

Processor 2 achieves the same basic result as Processor 1, but here the modified Note-On messages are limited to those with a velocity value of 1. These messages then have their value decreased by 1, which makes them 0 ($1-1 = 0$); and, finally, they are converted into Continuous Controller messages with a value of 0. The data modification taking place in Processor 2 is necessary, because the QX1 will not allow any Note-On messages to be entered with a velocity of 0. Since a Continuous Controller can only be turned off completely by a message with a value of 0, one of the Note-On messages for the QX1 must be modified to have a value of 0. An example of how this application is used is as follows:

Working with the QX1 now, I want to have a

chord decrease in volume from loudest to softest over two measures of 4/4 time, starting at measure 50 on Track #3. Since I want the change in volume to be as smooth as possible, I will use 128 different messages (the maximum) to achieve this result. Since two measures on the QX1 contain 3072 clocks, and since I want to use 128 messages, I will need to place my Note-On message every 24 clocks ($3072/128 = 24$). Therefore, when entering the Note-On messages, I will make the Note Length 24 clocks. I do not need to be particular about what note is actually entered, since the MEP4 will ignore this part of the Note-On message during the conversion.

In Edit Mode on the QX1, I now begin to enter the notes on Track #1 at measure 50, starting with a velocity of 127 and decreasing by 1 each time I enter a new note until I reach a note with a velocity of 1. Given the design of the QX1, it actually takes very little time to enter this many notes. I now enter Record Mode on the QX1, and set it to record on Track #2 (Record Mode Job Command #2). The QX1 MIDI OUT for Track #1 should be connected to the MEP4 MIDI IN, and the MEP4 MIDI OUT for Processor 1 should be connected to the QX1 MIDI IN. With Record Mode ready on the QX1, I record onto Track #2; until all the data has passed from Track #1 of the QX1 to Processors 1 and 2 of the MEP4 and back into the QX1 on Track #2.

Now, entering Edit Mode on Track #2, it can be seen that the Track contains Main Volume Controller messages in measures 50 and 51. These messages should be quantized (using Edit Mode Job Command #9) to whatever the original Note Length was (24 clocks in this case), since there is a slight delay in the time it takes the data to leave the QX1, enter the MEP4, be processed, leave the MEP4, and re-enter the QX1.

Now, all I need to do is merge Track #2 with the original Track #3 (using Utility Job Command #14), and then delete Track #1 and Track #2 (using Utility Job Command #15), since these tracks are no longer needed. Track #3 now contains the Note messages of the original chord, plus 128 Controller 07 (Main Volume) messages, starting with a value of 127 and decreasing to 0. When played, the chord will now make a very nice-sounding decrescendo over two measures.

Questions

Answers To Questions From Readers.

Using the FM Composer II Program (YRM501) for the CX5M, the Transpose function works only for the internal sounds, not for the MIDI sounds. Is there a way to implement a MIDI transpose function?

Yes: use the sm (send MIDI) function. Send the proper MIDI command to tell the receiving MIDI device to transpose, and it will.

Can you take voices from other synthesizers and put them into memory on a DX7?

Yes and no. Yes, it is possible to take voices from other Yamaha 6-operator FM digital synthesizers and put them into memory on a DX7. No, it is not possible to take voices created on instruments using other synthesizer technologies (such as, for instance, the Oberheim Matrix-6 or the Roland D-50) and enter them into memory on a DX7.

Even though MIDI makes it possible for different brands of instruments to share certain kinds of information, MIDI does not make it possible to take a voice from one kind of synthesizer and recreate it on a completely different kind of synthesizer. On the level of voice programming, synthesizers speak a number of different languages, which are not compatible with each other.

The Yamaha 6-operator units all share the same basic synthesizer components and the same approach to voice programming, so they can share patches. In the same way, expanded product lines developed by other manufacturers can also share patches with one another. However, there is no way that synthesizers with different synthesizer voice architecture can share patches with each other.

I own a Yamaha CPV-5 Clavinova, and enjoy it. However, since the unit doesn't seem to qualify as a Yamaha "professional" product, I find it very hard to get information on its MIDI capabilities. One recent example: I was

intrigued by the recent AfterTouch article on the TX1P (March '88), but found no indication of whether such a module could be used with my Clavinova. Can you help me?

Yes, we think we can help you. The CPV-5 Clavinova is equipped with (what have become) the standard basic MIDI functions. Its back panel includes both MIDI IN and MIDI OUT jacks. The unit receives MIDI information on all 16 MIDI channels, but sends MIDI information only on MIDI channel 1.

In other words, your Clavinova will work with just about any MIDI-equipped tone generator currently on the market. In order to control a tone generator using your Clavinova, simply connect the Clavinova's MIDI OUT to the tone generator's MIDI IN, and make sure that the tone generator is set to receive information on MIDI channel 1. To hear the sound output from both units, you will of course have to connect both of them to your sound reinforcement system.

Does Yamaha distribute any disks with patch banks for the DX7 II FD? If so, how can I obtain them?

There are number of disks available. For more information, contact your nearest authorized Yamaha DMI (Digital Musical Instruments) dealer. They can provide you with details on the prices and contents of the disks.

I work with a KX88 (as a master MIDI controller) and a DX7 II. Is it possible to assign the KX88's CS1 and CS2 to control the parameters that the DX7 II's CS1 and CS2 are assigned to control?

Yes, it is possible. First, assign the DX's CS1 and CS2 to specific MIDI IN Control Numbers (via the Control Number display accessed using the DX's MIDI 1 button—#31). Then, assign those same MIDI Control Numbers to CS1 and CS2 on the KX88 (following the procedures outlined

DX7 II FD digital FM synthesizer.



in the KX88 owners manual).

I am concerned about the longevity of my MT1X. I use it primarily for basic mix and EQ, but the drive motor is *always* running. Is this bad for the unit? Do I need to find a separate board, or is the recorder designed to be running when not in use?

The Yamaha Service Department reports that there is no reason to believe that your use of the MT1X will cause problems.

I own a DX21 and a Roland JX-8P. When I control the DX21 with the JX-8P via MIDI and use the portamento mode on the JX, the DX goes into portamento only some of the time. Also, when I shut portamento off on the JX, the DX portamento does not shut off most of the time. What is the problem?

MIDI portamento involves the use of two Controllers, and (therefore) two MIDI Controller numbers: the portamento switch (Controller #65) and portamento time (Controller #5). If the portamento switch is ON but the portamento time is set to 0, there will be no portamento effect.

One of the components of the DX21's Performance memory is a MIDI channel information switch: if this switch is off, the instrument will respond *only* to note data. The channel information switch must be *on* if you want the DX21 to receive MIDI Controller information. Also, remember that the MIDI channel information switch is programmed as part of a DX21 Performance memory: for consistent operation, it must be programmed as desired for *each* Performance memory.

LET US HEAR FROM YOU! We want AfterTouch to be an information network for *all* users of Yamaha professional musical products, so please join in. We're looking for many different kinds of material.

Have you created an incredible patch for the DX7 II, the DX100, or any of the other members of the Yamaha FM digital synthesizer family? How about a program for the CX5M II music computer or a great pattern or voice for the RX5? Send in your patches, programs, and patterns. If we use your material, we'll give you full credit plus \$25.00 for each item used.

Have you discovered a trick that increases the musical flexibility of one of the Yamaha AfterTouch products? Send it in to our "Hot Tips" column. If we use your hot tip, you'll receive full credit plus a check for \$25.00.

Have you developed a new approach to one of the Yamaha AfterTouch instruments, or have you discovered an important secret regarding their use? Put it on paper and send it to us. Don't worry about your writing style—just get the information down. If we decide to use your material as a full article in AfterTouch, we'll write it up, put your name on it, and send you a check for \$100.00. (An AfterTouch article always covers at least one magazine page—which translates to at least four double-spaced pages of typescript.)

By the way, we cannot assume liability for the safe return of unused ideas, patches, or manuscripts. We will only be able to return unused material if you enclose a self-addressed, stamped envelope with your submission.

If you just have a question regarding the use of Yamaha professional musical products, send it along too, and we'll do our best to answer it in the pages of AfterTouch. (We regret that we won't be able to answer questions through the mail, but we will use all of your questions to guide us in our choice of future topics.)

Finally, if you just want to get something off your chest, or if you'd like to establish direct contact with other Yamaha AfterTouch product users, send in something to our "Letters" column. We'll do our best to print names, addresses, and phone numbers of all those who are interested in starting up regional users groups.

AfterTouch is your publication. Let us hear from you!

Write To:
AFTER-
TOUCH,
P.O. Box 7938,
Northridge, CA
91327-7938.

AFTERTOUCHE
P.O. Box 7938
Northridge, CA 91327-7938

Bulk Rate
U.S. Postage
PAID
Long Prairie, MN
Permit No. 33