



# Waves MultiRack SoundGrid V9.7 for Yamaha Consoles Troubleshooting Guide





## Table of Contents

|  |    |
|--|----|
| 1. Introduction .....  | 3  |
| 2. Components Required for Establishing a MultiRack SoundGrid System ..... | 4  |
| 3. Proper System Configuration .....                                       | 6  |
| 4. Troubleshooting .....   | 10 |
| SoundGrid Preferences .....  | 10 |
| SoundGrid Inventory .....  | 11 |
| SoundGrid Connections.....   | 14 |
| 5. How Do I Know Which Version Is Installed? .....                         | 15 |
| 6. What Is Installed? .....  | 17 |
| 7. Physical Connection .....   | 18 |
| 8. FAQs.....   | 22 |
| Installation .....   | 22 |
| Usage.....   | 22 |
| Licenses.....  | 24 |
| 9. Appendices .....  | 25 |
| Appendix A: Servers .....  | 25 |
| Appendix B: WSG-Y16 DIP Switches.....                                      | 29 |
| Appendix C: SoundGrid-Compatible Switches.....                             | 31 |
| Appendix D: Ethernet Cables for SoundGrid Systems.....                     | 32 |
| Appendix E: Internet Protocol Version 6 (TCP/IPv6).....                    | 34 |
| Appendix F: Compatible Plugins & Latency Chart .....                       | 36 |
| 10. Contact Waves Tech Support.....  | 41 |



# 1. Introduction

The objective of this document is to help you troubleshoot Waves MultiRack SoundGrid for Yamaha consoles. This guide is written under the assumption that you have read and followed the setup instructions available on our website before attempting to fix your problem.

This guide is divided into five major sections:

1. Illustration of a functioning SoundGrid system
2. Guide to resolving problems with a non-functioning SoundGrid System
3. General information about SoundGrid system components
4. Frequently asked questions
5. Appendices



## 2. Components Required for Establishing a MultiRack SoundGrid System

- **[Yamaha WSG-Y16 card](#)**: Mini-YGDAI expansion card. Up to 4x WSG-Y16 cards, depending on console model. Each card provides 16 channels.

| Console Model                     | WSG-Y16 I/O cards |
|-----------------------------------|-------------------|
| PM5D / DM2000 / O2R96 / DME64N    | 4x WSG-Y16 cards  |
| M7CL / CL Series                  | 3x WSG-Y16 cards  |
| DM1000                            | 2x WSG-Y16 cards  |
| LS9 / O1V96 / DME24N / TXn series | 1x WSG-Y16 card   |

- **Waves qualified SoundGrid Server**: A multi-core PC used for real-time audio processing. [See a list of Waves-qualified servers in Appendix A: Servers.](#)
- **Network switch**: [See a list of Waves-qualified switches in Appendix C: SoundGrid-Compatible Switches.](#)
- **Ethernet Cables**: Standard Cat 5e or Cat 6 Ethernet cables. [See a list of supported length per cable type and application in Appendix D: Ethernet Cables for SoundGrid Systems.](#)
- **USB flash drive** with activated licenses for Waves SoundGrid-compatible plugins and the MultiRack SoundGrid application.

## SoundGrid Processing on a Single Computer

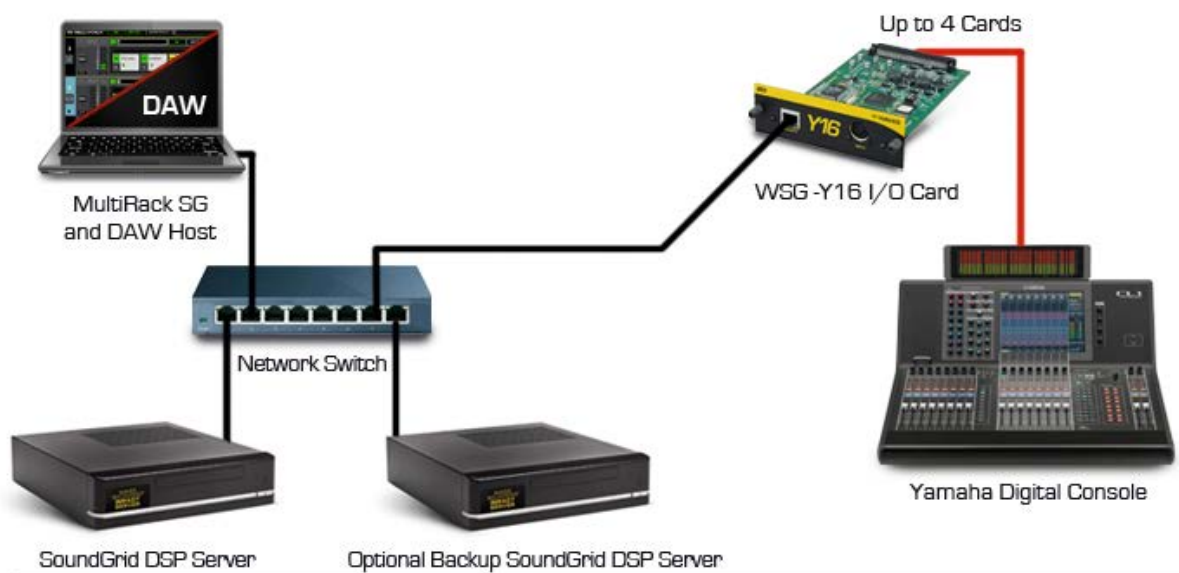

### 3. Proper System Configuration

This section displays the basic Windows and Settings of an operational Waves MultiRack SoundGrid System. Establish a proper system configuration by following the “Setup Instructions” below, which are also available online on our Download Page:

1. Launch the MultiRack SoundGrid application.
2. Go to the Preferences window.
  - a. PC: File > Preferences
  - b. Mac: MultiRack SoundGrid > Preferences

#### 3. General Tab Settings:

Link Status = Up    Link Speed = 1000 Mbps

SoundGrid Network Found

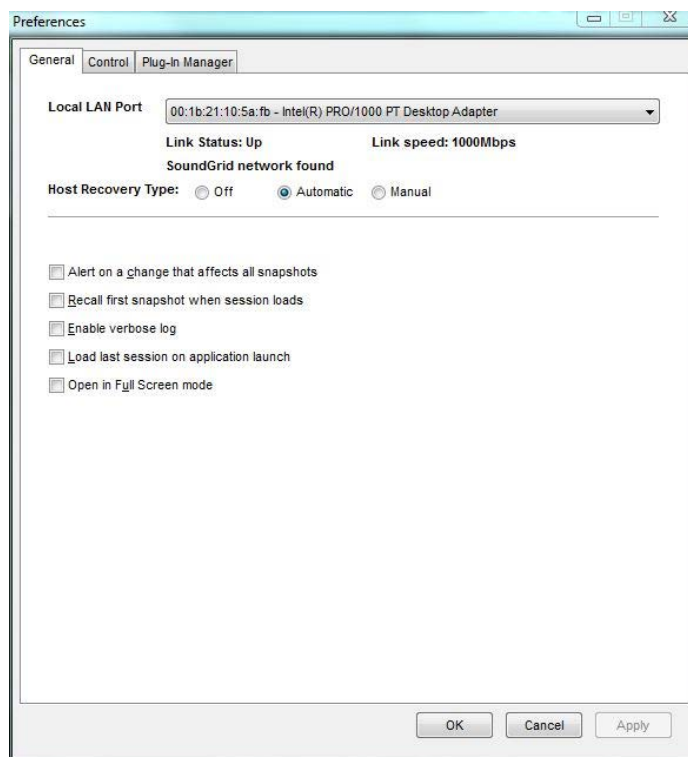

4. Plug-in Manager Tab Settings:

The plugin version you intend to use and have licenses for is checked.

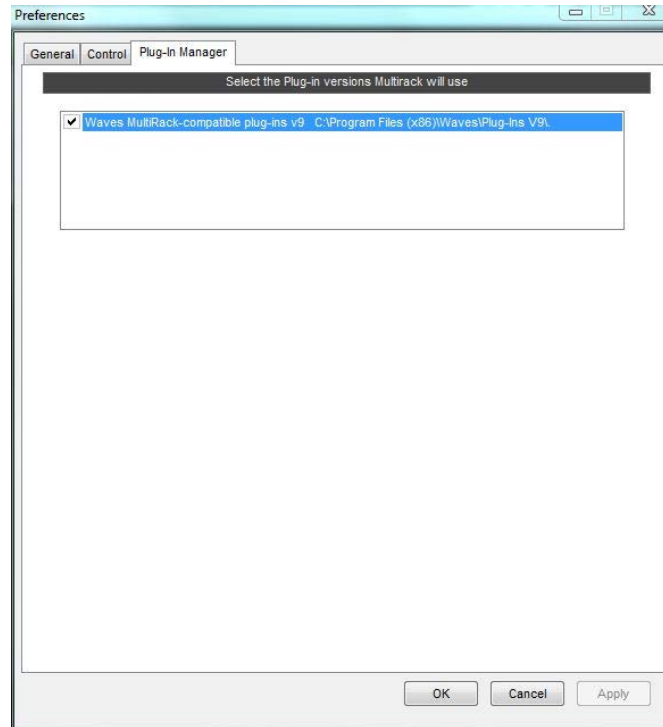

5. Go to Audio > SoundGrid Inventory

**SOUNDGRID INVENTORY** x

---

**SYSTEM PARAMETERS**

SAMPLE RATE  NETWORK LATENCY  DRIVER LATENCY

---

**SYSTEM INVENTORY** TEST REDUNDANCY REFRESH

---

**I/O DEVICES**

| ASSIGN                         | DEVICE         | CONTROL PANEL | CHANNEL                          | NAME        | MAC ADDRESS / COMPUTER NAME | STATUS | CLOCK        | MASTER                           | ID | DEVICE FIRMWARE |
|--------------------------------|----------------|---------------|----------------------------------|-------------|-----------------------------|--------|--------------|----------------------------------|----|-----------------|
| <input type="text" value="1"/> | IO: WSG-Y16    |               | <input type="text" value="16"/>  | WSG-Y16-1   | 00:1c:d1:00:01:9e           | On     | DIG: Sync OK | <input checked="" type="radio"/> | ID | UPDATE          |
| <input type="text" value="2"/> | IO: WSG-Y16    |               | <input type="text" value="16"/>  | WSG-Y16-2   | 00:1c:d1:00:01:86           | On     | DIG: Sync OK | <input type="radio"/>            | ID | UPDATE          |
| <input type="text" value="1"/> | MR: MultiRack  |               | <input type="text" value="128"/> | MultiRack-1 | 00:1b:21:10:5a:fb           | On     |              |                                  |    |                 |
| <input type="text" value="-"/> | DRV: SG Driver |               | <input type="text" value="32"/>  | SG Driver   | TECH56-764PC                | On     |              |                                  |    |                 |

---

**SOUNDGRID SERVERS**

| ASSIGN                         | DEVICE    | MAC ADDRESS / COMPUTER NAME | STATUS | DEVICE FIRMWARE |
|--------------------------------|-----------|-----------------------------|--------|-----------------|
| <input type="text" value="1"/> | SG Server | 70:71:bc:be:4e:0e           | On     | UPDATE          |



SoundGrid Inventory Settings:

**Sample Rate:** Matches the state of the console.

**Network and Driver Latency:** Correct settings depend on the server in use; Driver Latency depends on the driver (Host computer).

**I/O: WSG-Y16** is assigned and status is On. (When using more than one Y16 card, assign them consecutive numbers as shown above.)

**MR: MultiRack** is assigned and status is On.

**SG Server/s:** Assigned and status is On.

**Minimum Network Latency Settings**

|                | 48 kHz     | 96 kHz      |
|----------------|------------|-------------|
| Extreme Server | 40 samples | 80 samples  |
| Server One     | 40 samples | 80 samples  |
| Impact Server  | 56 samples | 112 samples |
| Compact Server | 96 samples | N/A         |

**Please Note:** In the SoundGrid Inventory window, the Network Latency range is 40 / 56 / 80 / 96 at a 48-kHz sampling rate, and 80 / 112 / 160 / 192 at a 96-kHz sampling rate.

- Go to Audio > SoundGrid Connections.

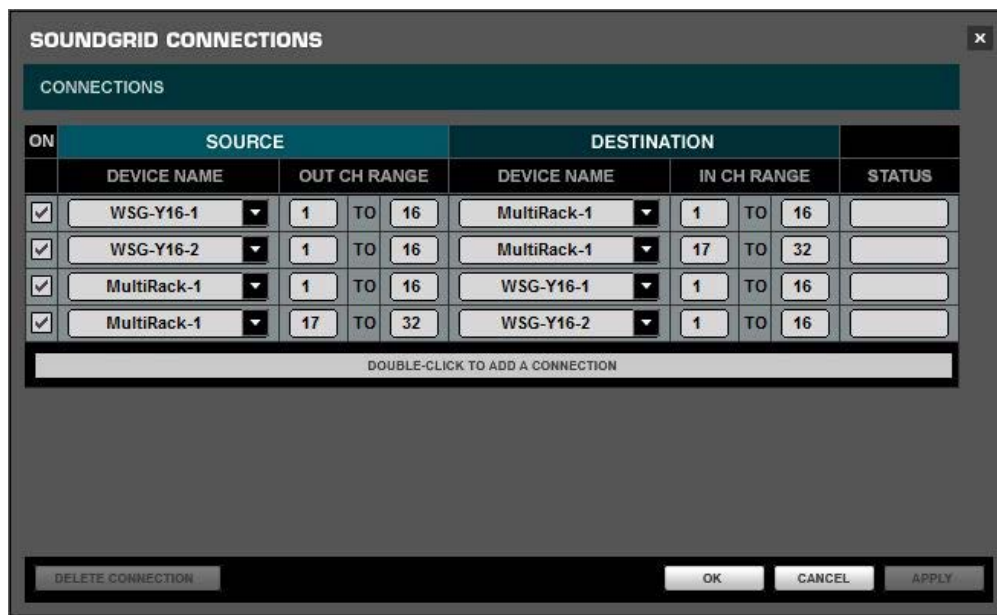





7. SoundGrid Connections Settings:

WSG-Y16 connection to MutliRack is checked.

MutliRack connection to WSG-Y16 is checked.

***Please Note:*** *When several WSG-Y16 cards are in use, the first card uses channels 1-16, the second channels 17-32, the third channels 33-48, and the fourth channels 49-64.*

## 4. Troubleshooting

If the message **ERR** appears in the MultiRack SoundGrid status window at any point after MultiRack SoundGrid has loaded, take the following steps to inspect all settings and system components:

### **SoundGrid Preferences**

1. Go to the Preferences window.

**PC:** File > Preferences

**Mac:** MultiRack SoundGrid > Preferences

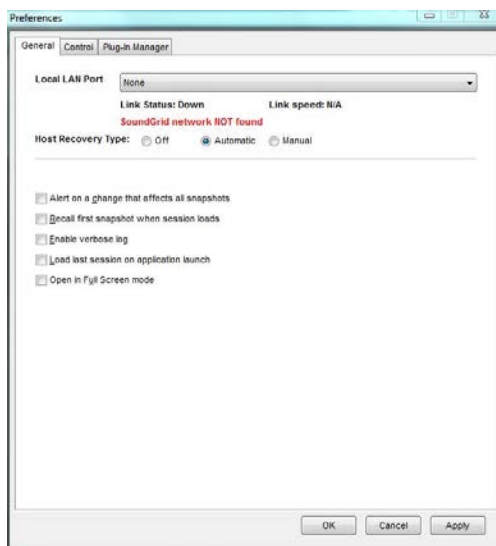

2. If you see the **SoundGrid network NOT found** message, and **Local LAN Port** is set to **None**, open the dropdown menu and set it to the LAN port connected to your SoundGrid network.



3. If you see the **SoundGrid network NOT found** message, and **Local LAN Port** is already set to the LAN port connected to your SoundGrid network , check the following:
  - a. If Link Status is UP and Link Speed is 1000 Mbps, this means that the I/O and the SoundGrid server are disconnected.
  - b. If Link Status is DOWN and Link Speed is N/A, this may be for one of the following reasons:
    - i. The switch is turned off or not compatible – [please refer to Appendix C: SoundGrid-Compatible Switches.](#)
    - ii. The Ethernet cable is disconnected or defective on the console (host) computer.
    - iii. Some or all cables may be too long or not compatible – [please refer to Appendix D: Ethernet Cables for SoundGrid Systems.](#)

If the SoundGrid Preferences are set correctly and the issue persists, check the SoundGrid Inventory window next.

## SoundGrid Inventory

Go to Audio > SoundGrid Inventory.

The screenshot shows the 'SOUNDGRID INVENTORY' window. At the top, 'SYSTEM PARAMETERS' includes 'SAMPLE RATE' set to 48000, 'NETWORK LATENCY' set to 40, and 'DRIVER LATENCY' set to 256. Below this is the 'SYSTEM INVENTORY' section with 'TEST REDUNDANCY' and 'REFRESH' buttons. The 'I/O DEVICES' table lists four items: two WSG-Y16 units (channels 16), a MultiRack-1 (channel 128), and an SG Driver (channel 32). The 'SOUNDGRID SERVERS' table lists one 'SG Server' with MAC address 70:71:bcc:be:4e:0e.

| SOUNDGRID INVENTORY |                |                             |         |                 |                             |        |                 |                                  |    |                 |  |
|---------------------|----------------|-----------------------------|---------|-----------------|-----------------------------|--------|-----------------|----------------------------------|----|-----------------|--|
| SYSTEM PARAMETERS   |                |                             |         |                 |                             |        |                 |                                  |    |                 |  |
| SAMPLE RATE         |                | 48000                       |         | NETWORK LATENCY |                             | 40     |                 | DRIVER LATENCY                   |    | 256             |  |
| SYSTEM INVENTORY    |                |                             |         |                 |                             |        |                 |                                  |    |                 |  |
| TEST REDUNDANCY     |                |                             |         |                 |                             |        |                 |                                  |    |                 |  |
| REFRESH             |                |                             |         |                 |                             |        |                 |                                  |    |                 |  |
| I/O DEVICES         |                |                             |         |                 |                             |        |                 |                                  |    |                 |  |
| ASSIGN              | DEVICE         | CONTROL PANEL               | CHANNEL | NAME            | MAC ADDRESS / COMPUTER NAME | STATUS | CLOCK           | MASTER                           | ID | DEVICE FIRMWARE |  |
| 1                   | IO: WSG-Y16    |                             | 16      | WSG-Y16-1       | 00:1c:d1:00:01:3e           | On     | DIG: Sync OK    | <input checked="" type="radio"/> | ID | UPDATE          |  |
| 2                   | IO: WSG-Y16    |                             | 16      | WSG-Y16-2       | 00:1c:d1:00:01:3e           | On     | DIG: Sync OK    | <input type="radio"/>            | ID | UPDATE          |  |
| 1                   | MR: MultiRack  |                             | 128     | MultiRack-1     | 00:1b:21:10:5a:fb           | On     |                 | <input type="radio"/>            |    |                 |  |
| -                   | DRV: SG Driver |                             | 32      | SG Driver       | TECHS6-764PC                | On     |                 |                                  |    |                 |  |
| SOUNDGRID SERVERS   |                |                             |         |                 |                             |        |                 |                                  |    |                 |  |
| ASSIGN              | DEVICE         | MAC ADDRESS / COMPUTER NAME |         |                 |                             | STATUS | DEVICE FIRMWARE |                                  |    |                 |  |
| 1                   | SG Server      | 70:71:bcc:be:4e:0e          |         |                 |                             | On     | UPDATE          |                                  |    |                 |  |

## IO: WSG-Y16

### Sample Rate

If the sample rate appears as **N/A**, this may be for the following reasons:

- **IO: WSG-Y16** is not assigned.
- If **IO: WSG-Y16** is assigned but appears as N/A, the card is not inserted in the slot properly.

To resolve this issue, take one of the following steps:

- If the **IO: WSG-Y16 Status** is On, assign the device. It should be functional now.
- If the **IO: WSG-Y16 Status** is NOT On, unassign **IO: WSG-Y16** and click Refresh.
- If the **IO: WSG-Y16** appears as Not Compatible, click Update. Once the firmware update has completed, you will be prompted to reboot the console.

If **IO: WSG-Y16** has disappeared from the list, this may be for one of the following reasons:

- Ethernet cable is disconnected from I/O or switch.
- Ethernet cable is disconnected from Host or switch.
- Ethernet cable is defective.
- Network switch is turned off.
- Network switch is not compatible (switch does not have 1GB connection). [Please refer to Appendix C: SoundGrid-Compatible Switches.](#)
- Ethernet cable is not compatible (not Cat 5e or Cat 6).
- Ethernet cables are too long: [please refer to Appendix D: Ethernet Cables for SoundGrid Systems.](#)
- The WSG-Y16 card is not inserted to the slot properly.
- WSG-Y16 I/O card is defective.



## SoundGrid Servers

Once you've confirmed that the I/O is functioning properly and is not the cause of the problem, check the SoundGrid server/s:

1. If **SG Server** Status is **On**, assign the device. It should be functional now.
2. If the **SG Server** Status is **N/A**, unassign it and press Refresh.
3. If **SG Server** appears as **Not Compatible**, press **Update**. Once the firmware update is complete, the server will automatically restart and the **Server Status** will be **On**. Next, assign **SG Server** to **1**. If a second redundant server is in use, repeat the same update process, and upon completion assign the redundant server to **2**.

If the SoundGrid server has disappeared from the list, this may be for the following reasons:

- Server is OFF.
- Ethernet cable is disconnected from server or switch.
- Ethernet cable is disconnected from host or switch. (Hint: in this case the I/O status will appear as **N/A**.)
- Ethernet cable is defective.
- Network switch is turned off.
- Network switch is not compatible (switch does not have 1GB connection): [please refer to Appendix C: SoundGrid-Compatible Switches](#).
- Ethernet cable is not compatible (not Cat 5e or Cat 6).
- Ethernet cables are too long: [please refer to Appendix D: Ethernet Cables for SoundGrid Systems](#).

If the SoundGrid server changes status from On to N/A upon assignment, this means that Internet Protocol Version 6 (IPv6) is not checked in the computer's Ethernet Card Preferences. [Please refer to Appendix E: Internet Protocol Version 6 \(TCP/IPv6\)](#).

## SoundGrid Connections

Go to Audio > SoundGrid Connections.

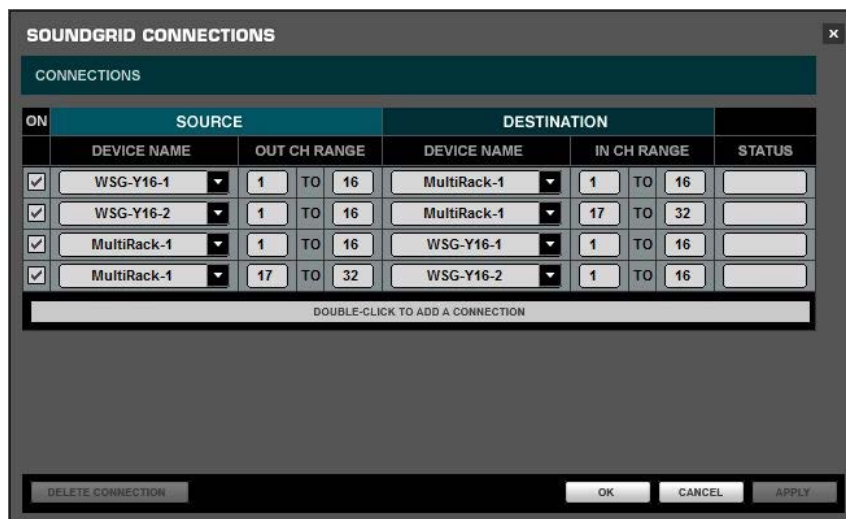

1. Make sure that the following connections are set up properly:
  - a. Source **WSG-Y16** to Destination **MultiRack**.
  - b. Source **MultiRack** to Destination **WSG-Y16**.
2. Turn Individual Connections On.

**Please Note:** When several WSG-Y16 cards are in use, the first card uses channels 1-16, the second channels 17-32, the third channels 33-48, and the fourth channels 49-64.

## 5. How Do I Know Which Version Is Installed?

Which version of MultiRack SoundGrid is installed is noted in the loading screen when you launch the MultiRack SoundGrid application. There are two other ways to determine which version is installed:

1. Go to the **About** window in the MultiRack SoundGrid application.
  - Windows: Go to Help > About
  - Mac: Go to MultiRack SoundGrid > About



2. Check the properties of the MultiRack SoundGrid application:
  - Windows : Navigate to C:\Program Files(x86)\Waves\ MultiRack folder, right click on the file named MultiRack SoundGrid, select “Properties,” and check the General tab.
  - Mac: Go to Applications > Waves > MultiRack, right-click on the file named MultiRack SoundGrid, and select “Get Info.”

Only the latest installer for each major version is available on our website. To make sure you have the latest version installed on your machine, check at

<http://www.waves.com/downloads/multirack> under the installer’s contents and compare versions.



The images below illustrate how hovering the mouse over a component in the Inventory window displays the current firmware version installed. (It is not possible to see this information if your firmware is listed as incompatible.)

1. Hovering mouse over **SoundGrid Servers** to view firmware version:

The screenshot shows the 'SOUNDGRID INVENTORY' window. At the top, there are 'SYSTEM PARAMETERS' including 'SAMPLE RATE' (48000), 'NETWORK LATENCY' (40), and 'DRIVER LATENCY' (256). Below this is the 'SYSTEM INVENTORY' section with 'TEST REDUNDANCY' and 'REFRESH' buttons. The 'I/O DEVICES' table lists three devices: 'IO: WSG-Y16', 'MR: MultiRack', and 'DRV: SG Driver'. The 'SOUNDGRID SERVERS' table has two rows. The first row is highlighted, and a tooltip 'Version: 9.5.30.1(1.1)' is visible over the 'DEVEICE' column.

| ASSIGN | DEVICE         | CONTROL PANEL | CHANNEL | NAME        | MAC ADDRESS / COMPUTER NAME | STATUS | CLOCK        | MASTER                           | ID | DEVICE FIRMWARE |
|--------|----------------|---------------|---------|-------------|-----------------------------|--------|--------------|----------------------------------|----|-----------------|
| 1      | IO: WSG-Y16    |               | 16      | WSG-Y16-1   | 00:1c:d1:00:01:9e           | On     | DIG: Sync OK | <input checked="" type="radio"/> | ID | UPDATE          |
| 1      | MR: MultiRack  |               | 128     | MultiRack-1 | 00:1b:21:10:5a:fb           | On     |              |                                  |    |                 |
| -      | DRV: SG Driver |               | 32      | SG Driver   | TECHS6-764PC                | On     |              |                                  |    |                 |

| ASSIGN | DEVICE    | MAC ADDRESS / COMPUTER NAME | STATUS | DEVICE FIRMWARE |
|--------|-----------|-----------------------------|--------|-----------------|
| 1      | SG Server | 00:15:17:cc:10:2a           | On     | UPDATE          |
| -      | SG Server | 70:71:bc:be:4e:0e           | On     | UPDATE          |

2. Hovering mouse over **IO: WSG-Y16** to view firmware version:

The screenshot shows the 'SOUNDGRID INVENTORY' window with the same parameters as the first image. In the 'I/O DEVICES' table, the first row is highlighted, and a tooltip 'Version: 1.11.8' is visible over the 'DEVEICE' column.

| ASSIGN | DEVICE         | CONTROL PANEL | CHANNEL | NAME        | MAC ADDRESS / COMPUTER NAME | STATUS | CLOCK        | MASTER                           | ID | DEVICE FIRMWARE |
|--------|----------------|---------------|---------|-------------|-----------------------------|--------|--------------|----------------------------------|----|-----------------|
| 1      | IO: WSG-Y16    |               | 16      | WSG-Y16-1   | 00:1c:d1:00:01:9e           | On     | DIG: Sync OK | <input checked="" type="radio"/> | ID | UPDATE          |
| 1      | MR: MultiRack  |               | 128     | MultiRack-1 | 00:1b:21:10:5a:fb           | On     |              |                                  |    |                 |
| -      | DRV: SG Driver |               | 32      | SG Driver   | TECHS6-764PC                | On     |              |                                  |    |                 |

| ASSIGN | DEVICE    | MAC ADDRESS / COMPUTER NAME | STATUS | DEVICE FIRMWARE |
|--------|-----------|-----------------------------|--------|-----------------|
| 1      | SG Server | 00:15:17:cc:10:2a           | On     | UPDATE          |
| -      | SG Server | 70:71:bc:be:4e:0e           | On     | UPDATE          |





## 6. What Is Installed?

After you run both the MultiRack application and the plugin installers, files will automatically be placed in their designated locations as listed below. [Do not move files manually.](#)

- Mac
  - Applications > Waves > SoundGrid
  - Applications > Waves > MultiRack
  - Applications > Waves > Plug-Ins V9
  - Applications > Waves > Waveshells
  - Macintosh HD > Users > Your User > Library > Caches
  - Macintosh HD > Users > Your User > Library > Preferences
  - Macintosh HD > Library > Application Support > Waves > SoundGrid Firmware
  - Macintosh HD > Library > Application Support > Waves > SoundGrid IO Modules
- PC
  - C:\Program Files(x86)\Waves\SoundGrid
  - C:\Program Files(x86)\Waves\MultiRack
  - C:\Program Files(x86)\Waves\SoundGrid Firmware
  - C:\ProgramData\Waves Audio\SoundGrid IO Modules
  - C:\Program Files(x86)\Waves\Plug-Ins V9
  - C:\Program Files(x86)\Waves\Waveshells
  - C:\Users\Current User\AppData\Roaming\Waves Audio – Caches & Preferences folders.

### Caches

When you load MultiRack SoundGrid for the first time, the application scans the system and creates cache files for the plugins. Cache files are created only when MultiRack SoundGrid is loading and licenses are being recognized. Since the files are created “on the fly,” loading time is longer when MultiRack SoundGrid loads and recognizes new licenses for the first time.

All installed plugins will appear in the plugin list regardless of the licenses recognized by the system. There is a difference between loading and instantiating a plugin. When trying to “instantiate” an unlicensed plugin within a session, the system will issue an authorization prompt. This may happen, for instance, when you add a plugin to a rack or open a session.

## 7. Physical Connection

The basic connections are illustrated in the image below.

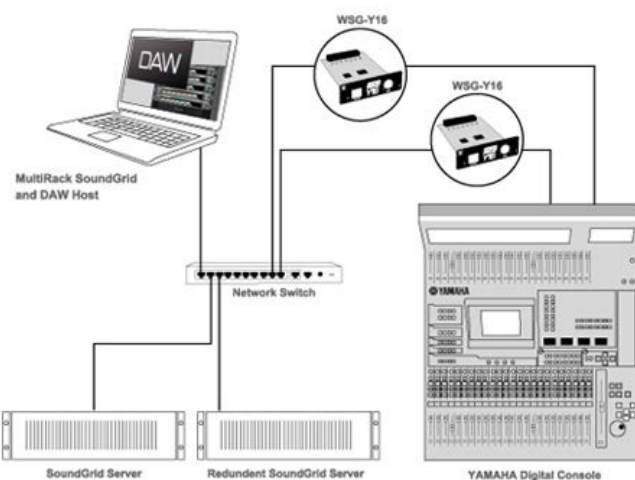

### Switch

A 1GB switch is required due to the amount of information flowing between the I/O and the servers. Insufficient link speed of various components will result in missing or N/A listings within the Inventory window. You can determine the link speed by looking at the indicators on the switch itself. There are indications on the Ethernet ports as well.

| Switch  | Led State Per Port   | Activity |
|---|--|----------|
| <b>ProSafe 8-Port Gigabit Ethernet Switch GS108v3</b>     | Left LED – 100 Mbps link<br>Right LED – 10 Mbps link<br>Both LEDs – 1000 Mbps link | Blinking |
| <b>HP 1410-16G (J9560A) 16-Port Rack Mountable Switch</b> | Link/Act – 10 or 100 Mbps<br>Speed ON – 1000 Mbps                                  | Blinking |

### Preferences Window

The Preferences window consists of three tabs:

- 1. General (Local LAN Port):** Lists all available network adapters. Choose the network adapter that is connected to the SoundGrid network. Network adapters are displayed by MAC

address and port name. When you select the proper port and all components are connected and recognized, the message “**SoundGrid Network Found**” will be displayed.

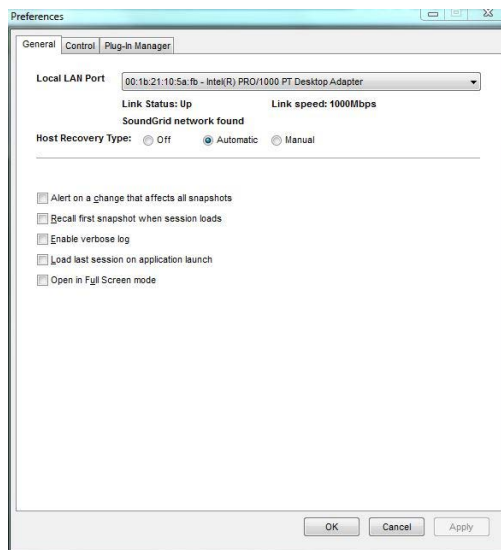

2. **Control:** Please see the Yamaha MIDI Remote Control Guide:

<http://www.waves.com/1lib/pdf/live/yamaha-midi-remote-control-guide.pdf>

3. **Plug-in Manager:**

Please note: MultiRack V9.7 supports V9 plugins only.

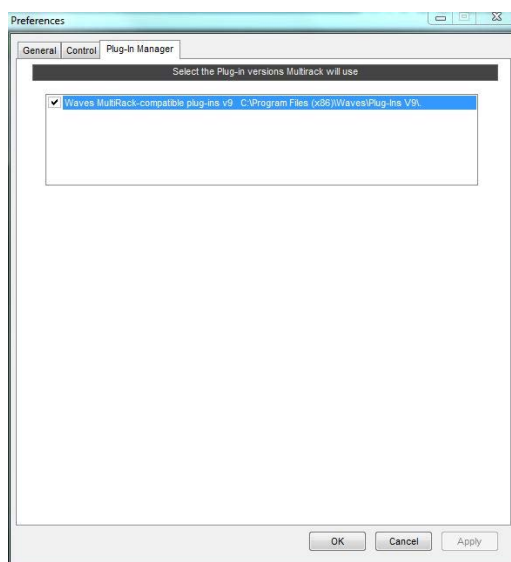



## Rescan Present Licenses

When you prepare a session and are routing without licenses, the plugin does not process audio, but you can still assign inserts and FX and load the plugin.

To enable a disabled plugin:

- Connect your USB flash drive (V9).
- Go to **Edit Menu** and click on “Rescan Present Licenses”. All disabled plugins will be enabled.
- You can re-enable plugins individually by right-clicking on any disabled ones and choosing the **Enable** option from the menu.

## Inventory Window

The Inventory window lists all of the SoundGrid components on your network and lets you select, assign, and update the devices you are using. The Device column lists all available components: I/O card, MultiRack (the processing device) and SG Servers (MultiRack’s processing engine).

*Please remember:* A device is not usable until it is assigned. Devices may be listed in the inventory window even if they are not connected or recognized. (Previously connected and assigned information is saved to a preference file).

It is important to pay attention to the Status column. There are four possible modes:

- 1. On:** Connected and available to be assigned.
- 2. In Use:** A different MultiRack SoundGrid or driver is connected to the same network and is controlling this device. The current instance of MultiRack SoundGrid will not be able to use this particular device.
- 3. N/A:** The device was originally assigned but is currently disconnected or unrecognized.
- 4. Incompatible:** The I/O or server firmware version does not match the version of MRSG installed. In such a case, click the “Update” button on the same device line.



**Sample Rate:** This field displays the sample rate. MultiRack SoundGrid is slaved to the console's sample rate at all times, and this field cannot be edited. Sample rate information is derived through the M-Waves I/O. If the I/O is faulty, disconnected, unrecognized, or unassigned, the Sample Rate field will display N/A.

**Network Latency:** The network latency value (40, 56, 80 or 96 at 48 kHz; 80, 112, 160 or 192 at 96 kHz) sets the buffering delay used by the processing SoundGrid server. For correct latency setting per server, [see the list of Waves-qualified servers in Appendix A: Servers](#).

Plugins can introduce or add latency to the overall system latency. A plugin latency chart can be viewed in [Appendix F: Compatible Plugins & Latency Chart](#).



## 8. FAQs

### *Installation*

**Q:** How do I know if I have the latest version of Waves on my system?

**A:** Refer to "[How Do I Know Which Version Is Installed?](#)"

**Q:** How do I update only MultiRack SoundGrid on my system?

**A:** Visit the [www.waves.com](http://www.waves.com) download page for MultiRack. A separate MultiRack SoundGrid installer is available.

**Q:** A new plugin has been released and I have updated my license. How do I install only this new plugin on my MultiRack SoundGrid?

**A:** Visit the [www.waves.com](http://www.waves.com) download page for MultiRack. A separate V9 plugin installer is available.

### *Usage*

**Q:** How do I rename racks?

**A:** It is possible to rename racks by clicking on Untitled next to the Rack On button and rename it.

**Q:** What do I need to do when a "**Please select Waves Public API (WPAPI) Folder**" message window appears?

**A:** If the file doesn't exist, or if you've selected the wrong folder, MultiRack will load without racks. You need to make sure that the right folder has been selected. Navigate to **PC:** C /Program File (x86)/ Common Files /WPAPI, **Mac:** HD /Library/Audio/Plugins/WPAPI and look for a file named Waveshell WPAPI, then click the "Select" button. If the problem is still not resolved, you will need to reinstall all MultiRack SoundGrid-compatible plugins.

**Q:** What do I need to do when a "**Please select Waves V9 Plug-in folder**" message window appears?



**A:** Navigate to the **Waves > Plug-ins V9** folder and press “Select.” If your selection is not accepted, you will need to reinstall all MultiRack SoundGrid-compatible plugins.

**Q:** What should my Network Latency be set to?

**A:** Network Latency refers to the processing latency. In general, lower settings will reduce the latency. However, keep in mind that lower latency settings will result in higher CPU loads. Please see the correct settings below:

***Minimum Network Latency Settings***

|                | 48 kHz     | 96 kHz      |
|----------------|------------|-------------|
| Extreme Server | 40 Samples | 80 Samples  |
| Server One     | 40 Samples | 80 Samples  |
| Impact Server  | 56 Samples | 112 Samples |
| Compact Server | 96 Samples | N/A         |

**Technical Note:** *In the Inventory window, the Network Latency range is 40 / 56 / 80 / 96 at a 48-kHz sampling rate..*

**Q:** What should I do if I hear clicks and pops or audio drop-outs?

**A:** Check the Network Latency and try to increase the parameters.

- Check the Transport reading: the highest functional value is 95%.
- Check the Processing Server via the System Monitor window (Audio>System Monitor): CPU Load Peak and CPU Load AVR (Average). High values may result in audio drop-outs.



## ***Licenses***

**Q:** Why are plugins listed for which I don't have a license?

**A:** All MRSRG-compatible plugins are present by default when installing Waves.

**Q:** How do I remove unlicensed plugins from the Insert list?

**A:** Please consult the console owner before taking any of the actions below:

1. Go to the **Plug-ins V9** folder.
3. Mac: Applications > Waves > Plug-Ins V9
4. PC: C:\Program Files(x86)\Waves\Plug-Ins V9
2. In this location, create an **Unused Plugins** folder.
3. Move the unlicensed plugin files to the **Unused Plugins** folder.

***Do not delete DLA, IDR, MultiRack, WavesLib or MultiRackLib (if listed).***

**Q:** What should I do if I get an authorization prompt stating that I don't have a license to use a certain plugin?

**A:** First, log into your Waves online account to view which licenses and version you own. Launch the Waves Licenses Center and make sure the licenses appear on a connected device.

**Q:** What should I do if the USB flash drive holding my V9 licenses is damaged or lost?

**A:** Open the Waves License Center on a computer connected to the internet and use the "Recover Licenses" option to re-activate your license to a new device.

**Q:** Some of my plugins are grayed out when I load a session.

**A:** Right-click on the plugin and select "Enable Plugin."



## 9. Appendices

### Appendix A: Servers

#### Waves SoundGrid Extreme Server



| System Description             | RAM | Motherboard          | LAN Card      |
|--------------------------------|-----|----------------------|---------------|
| Waves SoundGrid Extreme Server | 8GB | ASUS Rampage IV Gene | OnBoard Intel |

The benchmarks below are for general reference, illustrating how many racks and plugins can be run on this particular server. The following plugins were used for these tests: C4 Multiband Compressor, SSL E-Channel, IR-Live, and L3 Multimaximizer. Each rack was fully loaded with a specific plugin until maximum load was reached. M-Waves cards were used as audio interfaces in these tests.

| Server Benchmarks         | Test 1                | Test 2                |
|---------------------------|-----------------------|-----------------------|
| Sample rate               | 48 kHz                | 96 kHz                |
| Latency (roundtrip total) | 40* samples / 0.83 ms | 80* samples / 0.83 ms |
| SSL Channel Stereo        | 512 instances         | 288 instances         |
| IR-Live                   | 30 instances          | 18 instances          |
| L3 Multimaximizer         | 158 instances         | 64 instances          |
| C4 Mono                   | 512 instances         | 288 instances         |

#### Minimum Network Latency Settings

|             |             |
|-------------|-------------|
| 44.1/48 kHz | 88.2/96 kHz |
| 40 samples  | 80 samples  |

## Waves SoundGrid Server One



| System Description         | RAM | Motherboard      | LAN Card |
|----------------------------|-----|------------------|----------|
| Waves SoundGrid Server One | 4GB | Gigabyte GA-H81N | AddOn    |

The benchmarks below are for general reference, illustrating how many racks and plugins can be run on this particular server. The following plugins were used for these tests: C4 Multiband Compressor, SSL E-Channel, H-Delay, and TrueVerb. Each rack was fully loaded with a specific plugin until maximum load was reached. M-Waves cards were used as audio interfaces in these tests.

| Server Benchmarks         | Test 1                | Test 2                |
|---------------------------|-----------------------|-----------------------|
| Sample rate               | 48 kHz                | 96 kHz                |
| Latency (roundtrip total) | 40* samples / 0.83 ms | 80* samples / 0.83 ms |
| SSL Channel Mono          | 256 instances         | 128 instances         |
| H-Delay Mono              | 244 instances         | 128 instances         |
| TrueVerb Mono             | 160 instances         | 64 instances          |
| C4 Mono                   | 256 instances         | 128 instances         |

### *Minimum Network Latency Settings*

|                    |                    |
|--------------------|--------------------|
| <b>44.1/48 kHz</b> | <b>88.2/96 kHz</b> |
| 40 samples         | 80 samples         |

## Waves SoundGrid Impact Server



| System Description            | RAM | Motherboard      | LAN Card         |
|-------------------------------|-----|------------------|------------------|
| Waves SoundGrid Impact Server | 2GB | Gigabyte GA-H81N | Realtek RTL8111E |

The benchmarks below are for general reference, illustrating how many racks and plugins can be run on this particular server. The following plugins were used for these tests: C4 Multiband Compressor, SSL E-Channel, H-Delay, and TrueVerb. Each rack was fully loaded with a specific plugin until maximum load was reached. M-Waves cards were used as audio interfaces in these tests.

| Server Benchmarks         | Test 1               | Test 2                |
|---------------------------|----------------------|-----------------------|
| Sample rate               | 48 kHz               | 96 kHz                |
| Latency (roundtrip total) | 56* samples / 1.2 ms | 112* samples / 1.2 ms |
| SSL Channel Mono          | 321 instances        | 176 instances         |
| C6 Mono                   | 72 instances         | 36 instances          |
| H-Delay Mono              | 256 instances        | 104 instances         |
| TrueVerb Mono             | 96 instances         | 48 instances          |
| C4 Mono                   | 232 instances        | 120 instances         |

### *Minimum Network Latency Settings*

|                    |                    |
|--------------------|--------------------|
| <b>44.1/48 kHz</b> | <b>88.2/96 kHz</b> |
| 56 samples         | 112 samples        |

## Waves SoundGrid Compact Server



| System Description             | RAM | Motherboard                 | LAN Card              |
|--------------------------------|-----|-----------------------------|-----------------------|
| Waves SoundGrid Compact Server | 1GB | Intel® Desktop Board D525MW | Realtek 8111E Gigabit |

The benchmarks below are for general reference, illustrating how many plugin racks and plugins can be run on this particular server. The following plugins were used for these tests: C4 Multiband Compressor, SSL E-Channel, H-Delay, and TrueVerb. Each rack was fully loaded with a specific plugin until maximum load was reached. M-Waves cards were used as audio interfaces in these tests.

| Server Benchmarks         | Test 1            |
|---------------------------|-------------------|
| Sample rate               | 48 kHz            |
| Latency (roundtrip total) | 96* samples / 2ms |
| SSL Channel Mono          | 48 instances      |
| H-Delay Mono              | 28 instances      |
| TrueVerb Mono             | 16 instances      |
| C4 Mono                   | 36 instances      |

### *Minimum Network Latency Settings*

|             |             |
|-------------|-------------|
| 44.1/48 kHz | 88.2/96 kHz |
| 96 samples  | N/A         |



## Appendix B: WSG-Y16 DIP Switches

The DIP switches on the WSG-Y16 card are part of the card's internal hardware. Check them before you continue troubleshooting, as some of their settings can interfere with the troubleshooting process.

1. Turn off the console.
2. Take out the WSG-Y16 card/s.
3. For all DIP switches, **Up = On / Down = Off**.
  - i. Pin 1 – **On=88/96 / Off=44/48** – On= 8ch in/out / Off=16ch in/out
  - ii. Pin 2 – **On=Native/Generic mode / Off=Emulation mode**  
**We support Emulation mode only.**
  - iii. Pin 3 – **On=Boot Only / Off=Working Mode**.  
When Pin3 is on, you will not be able to assign I/Os on the card.
  - iv. Pin 4 – **N/A**

| Configuration / DIP Switches | OFF            | ON             | Preferred Mode  |
|------------------------------|----------------|----------------|---|
| 1                            | 44.1/48 kHz    | 88.2/96 kHz    | 88.2/96 kHz On = 8 in 8 out<br>44.1/48 kHz Off = 16 in 16 out |
| 2                            | Emulation mode | Native/Generic | Should always be OFF: We support Emulation mode only.         |
| 3                            | Working mode   | Boot           | Should always be OFF.   |
| 4                            | N/A            | N/A            | Should always be OFF.   |

### WSG-Y16 Card DIP Switches Diagram

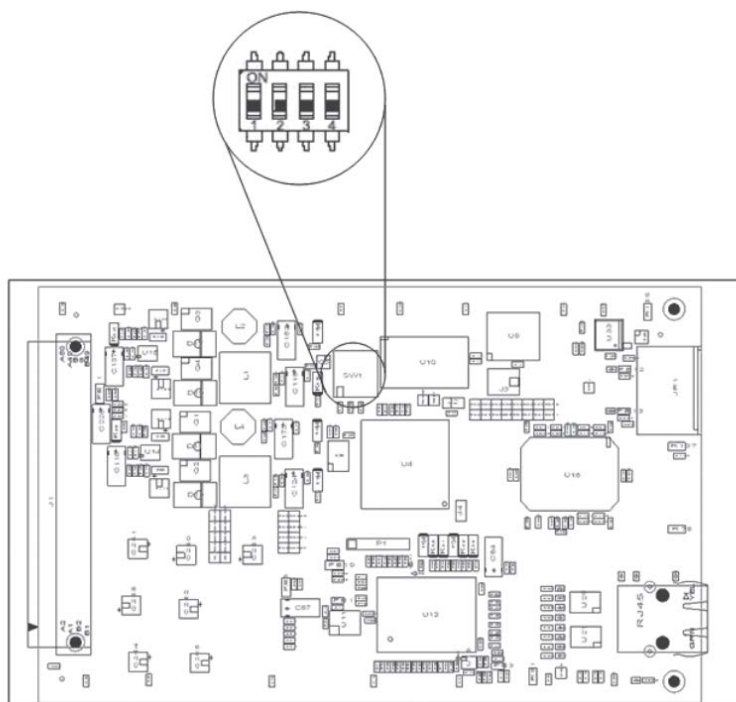



## ***Appendix C: SoundGrid-Compatible Switches***

Since Waves SoundGrid is an Ethernet-based protocol, it requires a network switch to connect all its components. For proper functioning, you will need to use a gigabit switch that supports jumbo frames.

**The following switches have been tested and certified for use with SoundGrid systems:**

- [Prosafe GS108v3 8-Ports gigabit switch](#)
- [HP 1410-16G Switch \(J9560A\) 16 port rack-mountable switch](#)

| <b>Switch</b>   | <b>Led State Per Port</b>  | <b>Activity</b> |
|---|--|-----------------|
| <b>ProSafe 8-Port Gigabit Ethernet Switch<br/>GS108v3</b>     | Left LED – 100 Mbps link<br>Right LED – 10 Mbps link<br>Both LEDs – 1000 Mbps link | Blinking        |
| <b>HP 1410-16G (J9560A) 16-Port Rack<br/>Mountable Switch</b> | Link/Act – 10 or 100 Mbps<br>Speed ON – 1000 Mbps                                  | Blinking        |



## Appendix D: Ethernet Cables for SoundGrid Systems

Consult this section to learn which cables and cable lengths can be used to connect the following components of a SoundGrid system:

- **I/Os:**
  - Waves I/O card for DiGiCo
  - WSG-Y16 card for Yamaha
  - M-Waves card for Allen & Heath (features an integrated 3-port switch)
  - DiGiGrid MGB (coaxial) or MGO (optical) MADI interfaces
- **SoundGrid Servers (SGS):** <http://www.waves.com/live-sound/soundgrid-servers>.
- **Switches:** Use only compatible switches. For a list of compatible switches, see <http://www.waves.com/live-sound/soundgrid-switches>.

### Cat 6 STP (Shielded Twisted Pair)

| Node                               | Length     | Remarks              |
|------------------------------------|------------|----------------------|
| I/O to switch                      | Up to 70 m |                      |
| SGS to switch                      | Up to 10 m |                      |
| MultiRack SG / SG Driver to Switch | Up to 70 m | With a 1000-Mbps NIC |
|                                    | Up to 20 m | With a 100-Mbps NIC  |

### Cat 5e STP (Shielded Twisted Pair)

| Node                               | Length     | Remarks |
|------------------------------------|------------|---------|
| I/O to switch                      | Up to 10 m |         |
| SGS to switch                      | Up to 5 m  |         |
| MultiRack SG / SG driver to switch | Up to 20 m |         |

**CAT5 cables are not supported.**



### **A Note on Using Joints (Cable Extenders)**

Joints or cable extenders should be used with care, as some models do not have electrically connected shielding, and using these might cause problems in areas with interference.

Total cable length, including the joint, may not exceed the above maximal cable length per node.

**Note:** We have tested the above cables with only one joint per line. More joints can possibly be used, but this scenario has not been tested.

## Appendix E: Internet Protocol Version 6 (TCP/IPv6)

Internet Protocol Version 6 is the latest Internet protocol that needs to be turned on for the SoundGrid server to work.

**IPv6-related issues may occur under two circumstances:**

1. SoundGrid server is assigned and status is N/A:

| SOUNDGRID SERVERS |           |                             |        |                 |
|-------------------|-----------|-----------------------------|--------|-----------------|
| ASSIGN            | DEVICE    | MAC ADDRESS / COMPUTER NAME | STATUS | DEVICE FIRMWARE |
| 1                 | SG Server | 00:15:17:c3:e4:4a           | N/A    | UPDATE          |
|                   |           |                             |        |                 |
|                   |           |                             |        |                 |

2. SoundGrid server is not assigned and status is ON:

| SOUNDGRID SERVERS |           |                             |        |                 |
|-------------------|-----------|-----------------------------|--------|-----------------|
| ASSIGN            | DEVICE    | MAC ADDRESS / COMPUTER NAME | STATUS | DEVICE FIRMWARE |
| -                 | SG Server | 00:15:17:c3:e4:4a           | On     | UPDATE          |
|                   |           |                             |        |                 |
|                   |           |                             |        |                 |

To resolve these issues, follow the instructions below:

### Windows:

1. Go to the **Control Panel > Network Connections** window.
2. Right-click on the network adapter connected to your SoundGrid network, then click on **Properties**.
3. Under **Networking Tab**, check the **Internet Protocol Version 6 (TCP/IPv6)** line.

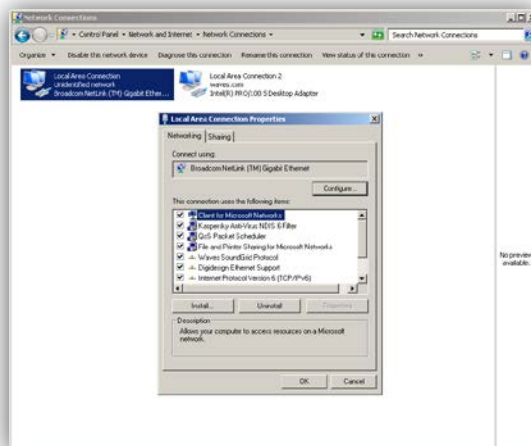

## Mac:

**Note:** The instructions below refer to OSX 10.6.8 (Snow Leopard) or lower. In higher OSX versions, **IPv6** is automatically on.

1. Go to System Preferences > Network.
2. Choose the network adapter you are using for your SoundGrid network, and click on **Advanced**.

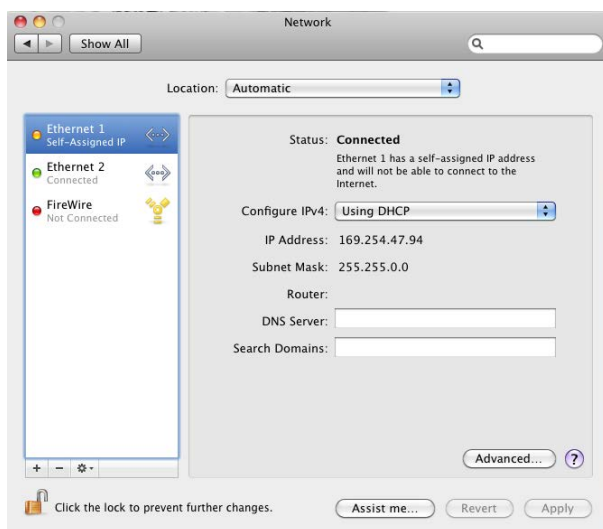

3. Open the **Configure IPv6** dropdown menu and change the setting to **Automatically**.

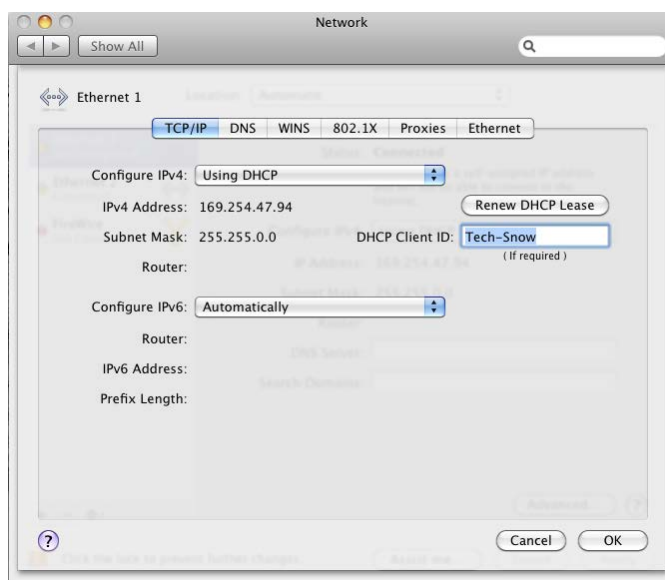



## Appendix F: Compatible Plugins & Latency Chart

Certain Waves plugins need to buffer the audio in order to process, resulting in what is known as latency.

The table below indicates how much latency (in samples) is produced by each Waves plugin.

| Plugin                      | 44.1/48 kHz                  | 88.2/96 kHz                  |
|-----------------------------|------------------------------|------------------------------|
| Aphex Vintage Aural Exciter | 0                            | 0                            |
| API 550A                    | 0                            | 0                            |
| API 550B                    | 0                            | 0                            |
| API 560                     | 65                           | 65                           |
| API 2500                    | 0                            | 0                            |
| AudioTrack                  | 0                            | 0                            |
| Bass Rider                  | 48 kHz: 2016                 | 96 kHz: 4032                 |
| Bass Rider Live             | 48 kHz: 240                  | 96 kHz: 480                  |
| C1 Compressor               | 0                            | 0                            |
| C1 Gate                     | 0                            | 0                            |
| C1 Comp-Gate                | 340                          | 96 kHz: 720                  |
| C1 Comp-sc                  | 340                          | 96 kHz: 720                  |
| C4 Multiband                | 64                           | 128                          |
| C6 Multiband                | 64                           | 128                          |
| Center                      | 48 kHz: 48                   | 96 kHz: 96                   |
| CLA Bass                    | 44.1 kHz: 133<br>48 kHz: 134 | 267                          |
| CLA Drums                   | 65                           | 129                          |
| CLA Effects                 | 44.1 kHz: 68<br>48 kHz: 69   | 138                          |
| CLA Guitars                 | 44.1 kHz: 100<br>48 kHz: 106 | 88.2 kHz: 208<br>96 kHz: 211 |
| CLA Unplugged               | 128                          | 256                          |
| CLA Vocals                  | 193                          | 385                          |
| CLA-2A                      | 0                            | 0                            |
| CLA-3A                      | 0                            | 0                            |

|                              |                              |                                |
|------------------------------|------------------------------|--------------------------------|
| CLA-76 Blacky & Bluey        | 0                            | 0                              |
| DeEsser                      | 0                            | 0                              |
| Doppler                      | 0                            | N/A                            |
| Doubler                      | 0                            | 0                              |
| Dugan Automixer              | 0                            | 0                              |
| Eddie Kramer Bass Channel    | 44.1 kHz: 493<br>48 kHz: 500 | 88.2 kHz: 602<br>96 kHz: 618   |
| Eddie Kramer Drum Channel    | 44.1 kHz: 410<br>48 kHz: 417 | 88.2 kHz: 562<br>96 kHz: 578   |
| Eddie Kramer Effects Channel | 0                            | 0                              |
| Eddie Kramer Guitar Channel  | 64                           | 128                            |
| Eddie Kramer Vocal Channel   | 149                          | 170                            |
| Enigma                       | 0                            | 0                              |
| GEQ Graphic Equalizer        | 3                            | 3                              |
| GTR3 Amps                    | 48 kHz: 40                   | 96 kHz: 81                     |
| GTR3 Stomps                  | 0                            | 0                              |
| H-Comp                       | 64                           | 128                            |
| H-Delay                      | 0                            | 0                              |
| H-EQ                         | 65                           | 0                              |
| InPhase & InPhase LT         | 48 kHz: 960                  | 96 kHz: 1920                   |
| InPhase & InPhase LT Live    | 0                            | 0                              |
| IR-Live Convolution Reverb   | 0                            | 0                              |
| J37 Tape                     | 101                          | 33                             |
| JJP Bass                     | 44.1 kHz: 409<br>48 kHz: 417 | 88.2 kHz: 561<br>96 kHz: 577   |
| JJP Cymbals & Percussions    | 44.1 kHz: 557<br>48 kHz: 565 | 88.2 kHz: 730<br>96 kHz: 746   |
| JJP Drums                    | 44.1 kHz: 622<br>48 kHz: 630 | 88.2 kHz: 859<br>96 kHz: 875   |
| JJP Guitars                  | 44.1 kHz: 622<br>48 kHz: 630 | 88.2 kHz: 859<br>96 kHz: 875   |
| JJP Strings & Keys           | 532                          | 88.2 kHz: 1046<br>96 kHz: 1104 |
| JJP Vocals                   | 44.1 kHz: 473<br>48 kHz: 481 | 88.2 kHz: 689<br>96 kHz: 705   |
| JJP PuigChild 660 & 670      | 0                            | 0                              |
| JJP PuigTec MEQ5             | 149                          | 170                            |
| JJP PuigTec EQP1A            | 149                          | 170                            |

|                                     |                              |                              |
|-------------------------------------|------------------------------|------------------------------|
| Kramer HLS Channel                  | 161                          | 161                          |
| Kramer Master Tape                  | 48 kHz: 64                   | 96 kHz: 128                  |
| Kramer PIE Compressor               | 0                            | 0                            |
| L1 Ultramaximizer                   | 64                           | 128                          |
| L2 Ultramaximizer                   | 64                           | 128                          |
| L3 Multimaximizer                   | 48 kHz: 3840                 | 96 kHz: 7680                 |
| L3 Ultramaximizer                   | 48 kHz: 3840                 | 96 kHz: 7680                 |
| L3-LL Multimaximizer                | 64                           | 128                          |
| L3-LL Ultramaximizer                | 64                           | 128                          |
| Linear Phase Equalizer<br>Broadband | 2679                         | 5360                         |
| Linear Phase Equalizer<br>Lowband   | 2047                         | 4095                         |
| Linear Phase Multiband              | 48 kHz: 3840                 | 96 kHz: 7680                 |
| LoAir                               | 0                            | 0                            |
| Maserati ACG                        | 64                           | 128                          |
| Maserati B72                        | 68                           | 132                          |
| Maserati DRM                        | 1                            | 1                            |
| Maserati GRP                        | 44.1 kHz: 621<br>48 kHz: 629 | 88.2 kHz: 858<br>96 kHz: 874 |
| Maserati GTi                        | 197                          | 389                          |
| Maserati HMX                        | 1                            | 1                            |
| Maserati VX1                        | 44.1 kHz: 408<br>48 kHz: 415 | 88.2 kHz: 560<br>96 kHz: 576 |
| MaxxBass                            | 0                            | 0                            |
| MaxxVolume                          | 64                           | 128                          |
| MetaFlanger                         | 0                            | 0                            |
| MondoMod                            | 0                            | 0                            |
| MV2                                 | 64                           | 128                          |
| NLS                                 | 4                            | 4                            |
| NS1                                 | 0                            | 0                            |
| OneKnob Brighter                    | 0                            | 0                            |
| OneKnob Driver                      | 48 kHz: 5                    | 10                           |
| OneKnob Filter                      | 0                            | 0                            |

|                                 |             |             |
|---------------------------------|-------------|-------------|
| OneKnob Louder                  | 64          | 128         |
| OneKnob Phatter                 | 0           | 0           |
| OneKnob Pressure                | 0           | 0           |
| OneKnob Wetter                  | 0           | 0           |
| PAZ Analyzer                    | 0           | 0           |
| PS22 Split / X-Split            | 4           | 4           |
| PS22 Spread                     | 2           | 2           |
| Q10                             | 0           | 0           |
| REDD.17                         | 0           | 0           |
| REDD.37-51                      | 65          | 0           |
| Renaissance Axx                 | 64          | 128         |
| Renaissance Bass                | 0           | 0           |
| Renaissance Channel             | 65          | 129         |
| Renaissance Compressor          | 64          | 128         |
| Renaissance DeEsser             | 64          | 128         |
| Renaissance Equalizer           | 0           | 0           |
| Renaissance Reverb              | 0           | 0           |
| Renaissance Vox                 | 64          | 128         |
| RS56 Passive EQ                 | 65          | 0           |
| S1 Stereo Imager                | 0           | 0           |
| Scheps 73                       | 65          | 0           |
| SoundShifter                    | 6946        | 13,858      |
| SSL E-Channel                   | 1           | 1           |
| SSL G-Channel                   |             |             |
| SSL G-Equalizer                 | 0           | 0           |
| SSL G-Master Buss<br>Compressor | 0           | 0           |
| SuperTap                        | 0           | 0           |
| The King's Microphones          | 48 kHz: 352 | 96 kHz: 448 |
| TransX Multi                    | 64          | 128         |
| TransX Wide                     | 64          | 128         |
| TrueVerb                        | 0           | 0           |



|                            |   |   |
|----------------------------|---|---|
| V-Comp                     | 0 | 0 |
| V-EQ3 / V-EQ4              | 0 | 0 |
| Vocal Rider                | 0 | 0 |
| WNS Waves Noise Suppressor | 0 | 0 |
| WLM Loudness Meter         | 0 | 0 |
| W43 Noise Reduction        | 0 | 0 |





## 10. Contact Waves Tech Support

### [Email Tech Support](#)

Phone: 1-865-909-9200, ext. 1

Fax: 1-901-328-6358

Monday–Thursday: 4:00 am–Midnight (EST)

Friday: 9:00 am–Midnight (EST)

Saturday–Sunday: 11:00 am–6:00 pm (EST)

Saturday: Urgent live sound requests only, also via VIP line +1-865-909-9277

Waves Tech Support is reserved for customers whose products are currently covered by the Waves Update Plan.