

Roland Drum System
V-Stage™ series

TD-12K

Owner's Manual

Thank you, and congratulations on your choice of the TD-12K Roland Drum System.

Before using this unit, carefully read the sections entitled: "USING THE UNIT SAFELY" (p. 2) and "IMPORTANT NOTES" (p. 4). These sections provide important information concerning the proper operation of the unit. Additionally, in order to feel assured that you have gained a good grasp of every feature provided by your new unit, Owner's manual should be read in its entirety. The manual should be saved and kept on hand as a convenient reference.





* *Kick Pedal and Hi-Hat stand are not included.*



Copyright © 2005 ROLAND CORPORATION

All rights reserved. No part of this publication may be reproduced in any form without the written permission of ROLAND CORPORATION.







USING THE UNIT SAFELY

INSTRUCTIONS FOR THE PREVENTION OF FIRE, ELECTRIC SHOCK, OR INJURY TO PERSONS

About  WARNING and  CAUTION Notices







 WARNING	Used for instructions intended to alert the user to the risk of death or severe injury should the unit be used improperly.
 CAUTION	Used for instructions intended to alert the user to the risk of injury or material damage should the unit be used improperly. * Material damage refers to damage or other adverse effects caused with respect to the home and all its furnishings, as well to domestic animals or pets.

About the Symbols







	The  symbol alerts the user to important instructions or warnings. The specific meaning of the symbol is determined by the design contained within the triangle. In the case of the symbol at left, it is used for general cautions, warnings, or alerts to danger.
	The  symbol alerts the user to items that must never be carried out (are forbidden). The specific thing that must not be done is indicated by the design contained within the circle. In the case of the symbol at left, it means that the unit must never be disassembled.
	The  symbol alerts the user to things that must be carried out. The specific thing that must be done is indicated by the design contained within the circle. In the case of the symbol at left, it means that the power-cord plug must be unplugged from the outlet.

ALWAYS OBSERVE THE FOLLOWING

WARNING

- Before using this unit, make sure to read the instructions below, and the Owner's Manual. 
- Do not open or perform any internal modifications on the unit. (The only exception would be where this manual provides specific instructions which should be followed in order to put in place user-installable options; see p. 7, p. 8, and p. 11.) 
- Do not attempt to repair the unit, or replace parts within it (except when this manual provides specific instructions directing you to do so). Refer all servicing to your retailer, the nearest Roland Service Center, or an authorized Roland distributor, as listed on the "Information" page. 
- Never use or store the unit in places that are:
 - Subject to temperature extremes (e.g., direct sunlight in an enclosed vehicle, near a heating duct, on top of heat-generating equipment); or are 
 - Damp (e.g., baths, washrooms, on wet floors); or are 
 - Humid; or are
 - Exposed to rain; or are
 - Dusty; or are
 - Subject to high levels of vibration.
- This unit should be used only with a rack or stand that is recommended by Roland. 

WARNING

- When using the unit with a rack or stand recommended by Roland, the rack or stand must be carefully placed so it is level and sure to remain stable. If not using a rack or stand, you still need to make sure that any location you choose for placing the unit provides a level surface that will properly support the unit, and keep it from wobbling. 
- Make sure you always have the unit placed so it is level and sure to remain stable. Never place it on stands that could wobble, or on inclined surfaces. 
- Do not allow any objects (e.g., flammable material, coins, pins); or liquids of any kind (water, soft drinks, etc.) to penetrate the unit. 

- In households with small children, an adult should provide supervision until the child is capable of following all the rules essential for the safe operation of the unit. 
- Protect the unit from strong impact. (Do not drop it!) 

 **CAUTION**

- Try to prevent cords and cables from becoming entangled. Also, all cords and cables should be placed so they are out of the reach of children. 

- Never climb on top of, nor place heavy objects on the unit. 

- Install only the accessories or parts to the drum stand that are recommended by Roland. Remove only the specified screws during the installation. 

- Should you remove screws, tuning bolts, washers, lock bushings, etc., keep them in a safe place out of children's reach, so there is no chance of them being swallowed accidentally. 

- Assemble the drum stand and TD-12K with care to avoid danger of pinching the fingers. 

- Make sure to firmly tighten all hand knobs and screws after you have assembled the drum stand and attached any components. You should probably also try to make a habit of checking and retightening them if necessary before every performance. You risk injury if you have loose screws or hand knobs, since a pad or component can fall unexpectedly. 

 **CAUTION**

- Do not apply excessive force to the sensor (and on the KD-85, the cushion) located below the center of the head of the KD-85, PD-105, and PD-85. Doing so can interfere with accurate detection, and may damage it. 

- Due to the nature of the materials used in the sensor of the KD-85, PD-105, and PD-85, changes in room temperature may affect the sensitivity of the sensor. 

- Please be aware that by using a felt beater for the KD-85, you risk causing damage to the head as a result of the metal portions of the beater that can become exposed when the felt wears thin. For the kick pedal, we recommend that you use only the supplied beater, or a commercially available plastic beater. 

- To keep the KD-85 from slipping or moving during play, the tips of the legs installed on the stay are pointed. Handle with care to avoid injury. 

- Brushes can be used to play the PD-105 and PD-85. When using brushes, be sure to use nylon brushes. Using metal brushes will not only scratch the head, but can also be hazardous, since the tip of the brush may catch in the mesh of the net. 

- The hoop's rubber portion is one component that eventually wears out (the more so if numerous rim shots are performed), and will require replacement. Rim shots may not be performed correctly when the rubber portion is worn out. If this occurs, replace the hoop rubber. Consult Roland Service for more on replacing the hoop rubber. 



This product complies with the requirements of European Directive 89/336/EEC.

For EU Countries

IMPORTANT NOTES

In addition to the items listed under “USING THE UNIT SAFELY” on pages 2–3, please read and observe the following:

Placement

- Do not expose the unit to direct sunlight, place it near devices that radiate heat, leave it inside an enclosed vehicle, or otherwise subject it to temperature extremes. Excessive heat can deform or discolor the unit.
- When moved from one location to another where the temperature and/or humidity is very different, water droplets (condensation) may form inside the unit. Damage or malfunction may result if you attempt to use the unit in this condition. Therefore, before using the unit, you must allow it to stand for several hours, until the condensation has completely evaporated.
- Do not allow rubber, vinyl, or similar materials to remain on the unit for long periods of time. Such objects can discolor or otherwise harmfully affect the finish.

Maintenance

- For everyday cleaning wipe the unit with a soft, dry cloth or one that has been slightly dampened with water. To remove stubborn dirt, use a cloth impregnated with a mild, non-abrasive detergent. Afterwards, be sure to wipe the unit thoroughly with a soft, dry cloth.
- Never use benzene, thinners, alcohol or solvents of any kind, to avoid the possibility of discoloration and/or deformation.

Additional Precautions

- Use a reasonable amount of care when using the unit’s buttons, sliders, or other controls; and when using its jacks and connectors. Rough handling can lead to malfunctions.
- When connecting / disconnecting all cables, grasp the connector itself—never pull on the cable. This way you will avoid causing shorts, or damage to the cable’s internal elements.
- To avoid disturbing your neighbors, try to keep the unit’s volume at reasonable levels. You may prefer to use headphones, so you do not need to be concerned about those around you (especially when it is late at night).
- This instrument is designed to minimize the extraneous sounds produced when it’s played. However, since sound vibrations can be transmitted through floors and walls to a greater degree than expected, take care not to allow these sounds to become a nuisance to neighbors, especially when performing at night and when using headphones.
- When you need to transport the unit, package it in the box (including padding) that it came in, if possible. Otherwise, you will need to use equivalent packaging materials.

Check the Contents of the Box

- ❑ TD-12 (Percussion Sound Module) x 1
- ❑ VH-11 (V-Hi-Hat) x 1
- ❑ KD-85 (V-Kick Trigger Pad) x 1
- ❑ PD-105 (V-Pad) x 1
- ❑ PD-85 (V-Pad) x 3
- ❑ CY-12R/C (V-Cymbal Ride/Crash) x 2
- ❑ Tuning Key x 1
- ❑ VH-11 Owner's Manual
- TD-12K Owner's Manual (this manual) x 1

MEMO

- The tuning key is included in the VH-11 package.
- The TD-12 Owner's Manual is included in the TD-12 package.
- This package does not include a kick pedal and a hi-hat stand. Use with a commercially available kick pedal and hi-hat stand.

MDS-12 (Drum Stand)

Assemble the Drum Stand.



About the Stand, refer to the MDS-12 Owner's Manual.

Caution in Setting Up the Stand

- Do NOT open the legs of the stand more than 135 degrees. The distance between the back Right/Left end legs should NOT be more than 1.5 m (60 inches), otherwise, the cable (inside the Pipes) could be damaged and/or the stand could tip over.

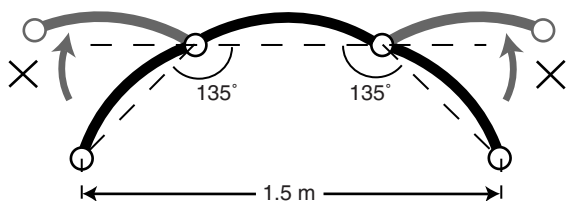

- Do NOT loosen any bolts other than Hand Knobs except when changing the parts or cables for repairing.

TD-12 (Percussion Sound Module)

Attach the stand holder (included with the drum stand MDS-12) to the TD-12.

Using the screws attached to the bottom panel, attach the holder so the unit is oriented as shown in the diagram.

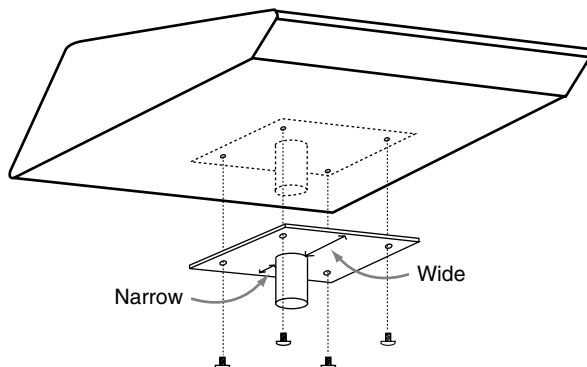

NOTE

- To attach the stand holder, remove the four 12 mm screws (M5 x 12) from the bottom of the TD-12 and use them. Use of other screws may result in damage to the unit.
- When turning the unit upside-down, get a bunch of newspapers or magazines, and place them under the four corners or at both ends to prevent damage to the buttons and controls. Also, you should try to orient the unit so no buttons or controls get damaged.
- When turning the unit upside-down, handle with care to avoid dropping it, or allowing it to fall or tip over.

VH-11 (V-Hi-Hat)

Mount the VH-11 on a commercially available hi-hat stand.



Refer to the VH-11 Owner's Manual.

KD-85 (V-Kick Trigger Pad)

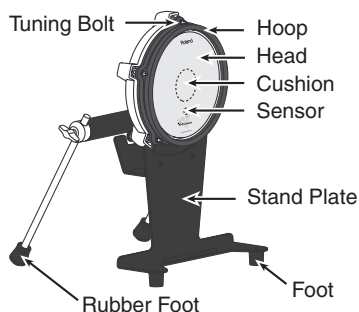
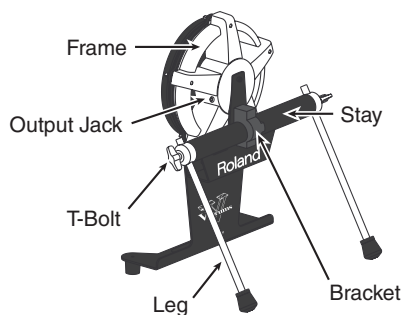

Adjusting the Head Tension

When adjusting, use the tuning key supplied with the VH-11.

Be sure to adjust the head tension before use.

In general, a tension that produces a strike response approximately the same as an acoustic drum will be appropriate.

NOTE

- Striking the head when the head tension is loose may damage the sensor and head.
- Should you neglect to make the appropriate settings, you could likely experience the following problems:
Sometimes it does not sound (uneven volume).
The volume is too low (reduced sensitivity).

MEMO

- On the KD-85, adjusting the head tension affects only the head response, and does not change the pitch of the sound as it would on an acoustic drum.
- The head tension will change as the instrument is used, so you should readjust when necessary.

1. Use the tuning key supplied with the VH-11 to tighten the tuning bolts.

Tighten the bolts to keep the space even all around between the frame and the hoop.

* The setup includes a lock bushing (to prevent loosening), so the bolt should be tightened fairly securely.

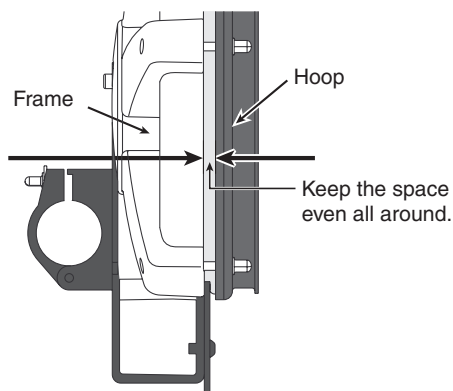

NOTE

Tighten each tuning bolt one by one, observing the numerical order shown in the diagram. Do not firmly tighten a single tuning bolt by itself. Doing so will make it impossible to tension the head evenly, and will cause malfunctions.

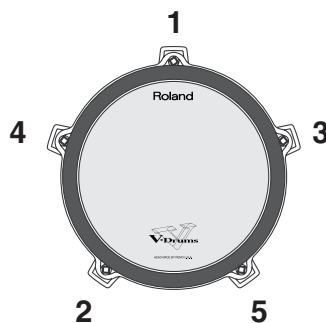

2. Tension the head evenly while checking the feel of striking the pad.

Normally, it would be appropriate if the tension is the same as an acoustic drum.

Assembling the KD-85

NOTE

Take care not to pinch your fingers between the KD-85 pad and the stand plate.

1. Place the KD-85 pad, with the head surface facing downward, on a flat surface such as the floor.

2. Use the tuning key supplied with the VH-11 to loosen the bolts for the bracket on the back of the KD-85 pad, then open the bracket.

3. Mount the stay on the pad.

Align the mark on the stay with the protrusion of the bracket, and use the tuning key to firmly tighten the bolts that you loosened in step 2.

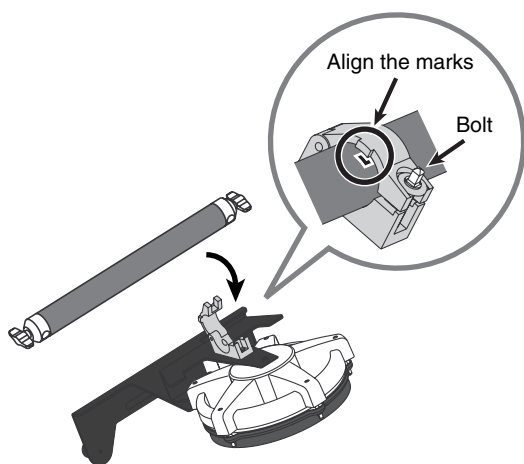

4. Loosen the leg nut.

5. Rotate the rubber foot to adjust the leg tip.

Adjust to use the spike legs when installing on carpeting or other soft surfaces, or the rubber legs when installing on flooring or other hard surfaces. When shipped from the factory, the stand is adjusted for using the rubber legs.

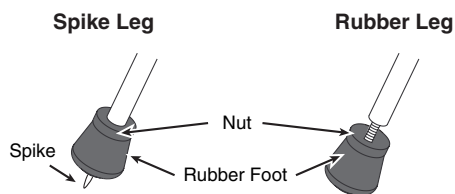

NOTE

- The tip of the spike is sharp. Handle it with care.
- When using on flooring, the spike legs may damage the floor. Adjust to use the rubber legs.

6. Tighten the nut and rubber foot to secure the rubber foot in place and keep it from loosening.

The nut and rubber foot must be tightened to prevent the malfunctions.

7. Loosen the T-bolts for the stay and mount the legs on the stay.

Install the legs as shown in the figure so that the ends of the legs protrude by about 1/2"-1" (1-2 cm).

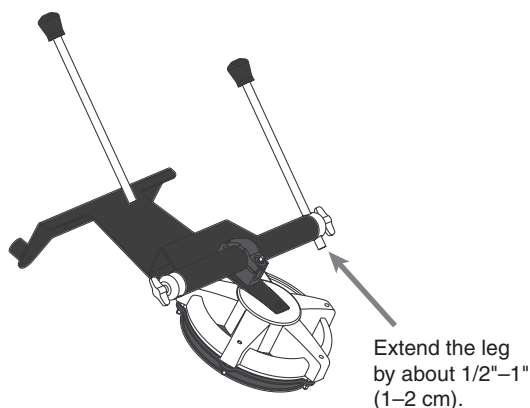

8. Tighten the T-bolts to secure the legs to the stand.

9. Lift the KD-85 and place the stand and the four legs upright.

10. Adjust the angle of the stand plate so that it's at a right angle to the floor.

Loosen the T-bolts that you tightened in step 8, and adjust the length of the legs so that the stand plate is vertical to the floor. Then firmly tighten the T-bolts.

11. Install the included beater on your kick pedal.

12. Mount the kick pedal on the KD-85.

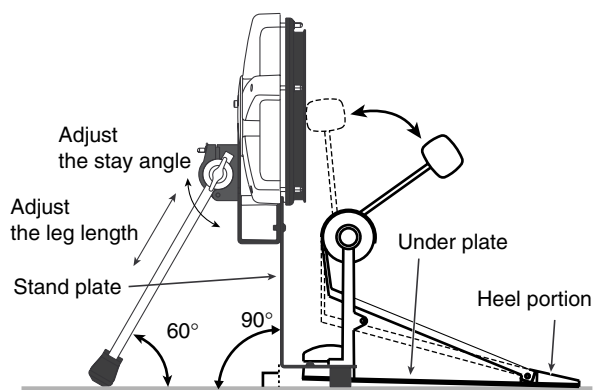

* Install the kick pedal securely.

* Set the KD-85 so no mechanical noise is heard when you step on pedal.

* Make sure that KD-85 does not touch the drum stand or the other pads.

To Obtain More Stability

If you are using a kick pedal with an under plate

Adjust the length of the legs and the angle of the stay so that the four legs of the KD-85 and the heel of the kick pedal contact the floor evenly.

13. Adjust the striking point for the beater.

The beater's striking point is adjusted to fall at the center of the head.

Adjust the striking point so that it doesn't extend beyond the cushion on the back of the head.

When Using a Twin (Double Kick) Pedal

With the KD-85, you can also play using a twin (double kick) pedal.

Set this up so the striking points of the two beaters fall at equal distances to the left and right of the center of the head.

NOTE

When using a twin (double kick) pedal, as with a regular pedal, use the included beater or a plastic beater as the beater for the kick pedal.

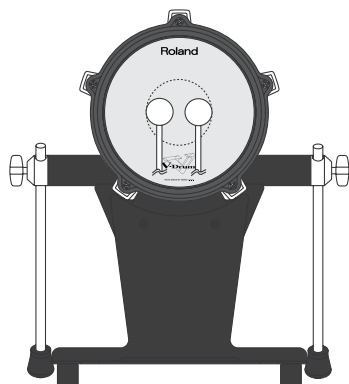

MEMO

As needed, adjust the sensitivity parameter of the sound module.

Replacing the Head

When the Head Should Be Replaced

The head is an expendable item that eventually will wear out and need to be replaced. Replace the head when the following occurs:

- The head surface is torn
- Slack portions remain in the head even when the head tension is properly adjusted.

Replacement heads (optional): MH-8 Mesh Head

1. Remove the kick pedal from the KD-85.
2. Remove all tuning bolts and washers from the KD-85.

Press the lock bushing (in figure below) in place with your finger as you remove each tuning bolt, to prevent the bushings from being pulled off the frame.

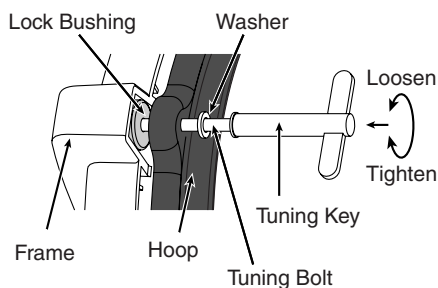

* The lock bushings prevent rotation and loosening of the tuning bolts caused by vibrations that are transmitted from the hoop as you play.

3. Remove the hoop.
4. Remove the old head.
5. Place the new head on the frame.
6. Place the hoop onto the head.
7. Pass the tuning bolts through the washers, then attach them to the hoop and frame.
8. Next, adjust the tension of the head (p. 6).

* Do not firmly tighten a single tuning bolt by itself. Doing so will make it impossible to tension the head evenly, and will cause malfunctions.

MEMO

If a lock bushing happens to become separated from the frame while the head is being replaced, position the bushing so its four slots are aligned with the corresponding ridges in the frame, then press down firmly on the bushing.

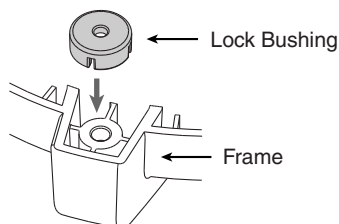

PD-105 (V-Pad)

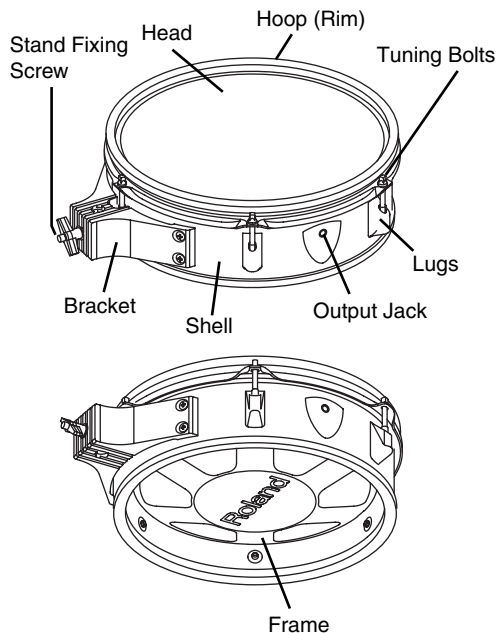

Adjusting the Head Tension

When adjusting, use the tuning key supplied with the VH-11.

Be sure to adjust the head tension before use.

In general, a tension that produces a strike response approximately the same as an acoustic drum will be appropriate.

NOTE

- Striking the head when the head tension is loose may damage the sensor and head.
- Should you neglect to make the appropriate settings, you could likely experience the following problems:
Sometimes it does not sound (uneven volume).
The volume is too low (reduced sensitivity).

MEMO

- On the PD-105, adjusting the head tension affects only the head response, and does not change the pitch of the sound, as it would on an acoustic drum.
- The head tension will change as the instrument is used, so you should readjust when necessary.
- The head stretches when used for extended periods, so even when this is adjusted in the following procedure, you may not achieve the same degree of tension as when the head was initially adjusted. Strike the head to check the feel and response as you adjust the tension.

1. Loosen the tuning bolts until a slight gap is produced.
2. Tighten all tuning bolts by fingers, as tightly as you can.

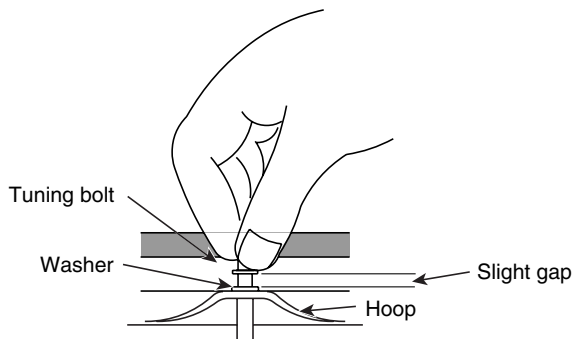

3. Using the tuning key, turn the tuning bolts two full revolutions each, thus tightening them.

Tighten each tuning bolt one by one, observing the numerical order shown in the figure.

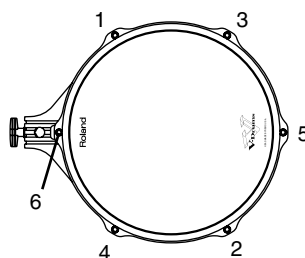

Attaching the Pad to a Stand

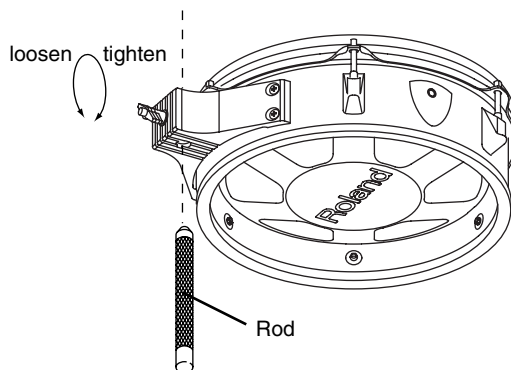

NOTE

When attaching the PD-105 to the mount, be sure to tighten the stand fixing screw securely. If it remains loose, the pad could fall off.

PD-85 (V-Pad)

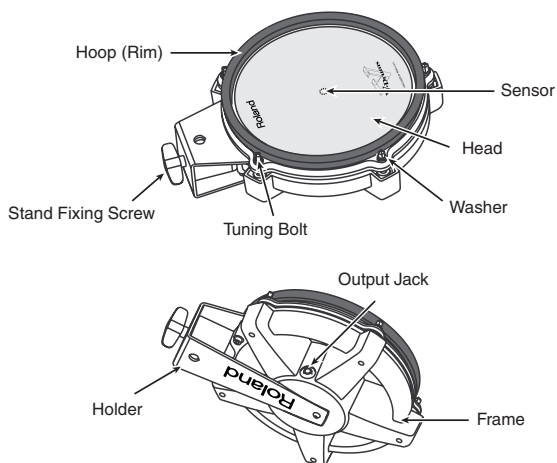

Adjusting the Head Tension

When adjusting, use the tuning key supplied with the VH-11.

Be sure to adjust the head tension before use.

In general, a tension that produces a strike response approximately the same as an acoustic drum will be appropriate.

NOTE

- Striking the head when the head tension is loose may damage the sensor and head.
- Should you neglect to make the appropriate settings, you could likely experience the following problems:
Sometimes it does not sound (uneven volume).
The volume is too low (reduced sensitivity).

MEMO

- On the PD-85, adjusting the head tension affects only the head response, and does not change the pitch of the sound, as it would on an acoustic drum.
- The head tension will change as the instrument is used, so you should readjust when necessary.

1. Use the tuning key supplied with the VH-11 to tighten the tuning bolts.

Tighten the bolts to keep the space even all around between the frame and the hoop.

- * The setup includes a lock bushing (to prevent loosening), so the bolt should be tightened fairly securely.

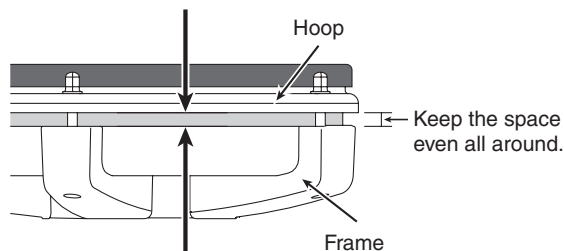

NOTE

Tighten each tuning bolt one by one, observing the numerical order shown in the diagram. Do not firmly tighten a single tuning bolt by itself. Doing so will make it impossible to tension the head evenly, and will cause malfunctions such as failure to accurately detect the striking location.

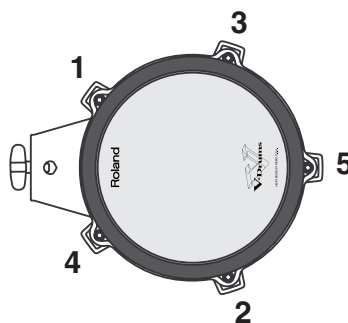

2. Tension the head evenly while checking the feel of striking the pad.

Normally, it would be appropriate if the tension is the same as an acoustic drum.

Attaching the Pad to a Stand

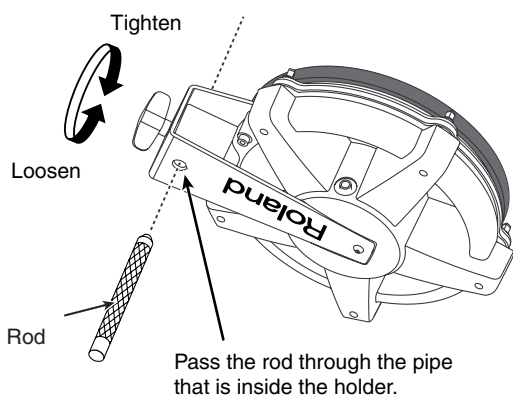

NOTE

When attaching the PD-85 to the mount, be sure to tighten the stand fixing screw securely. If it remains loose, the pad could fall off.

Replacing the Head

When the Head Should Be Replaced

The head is an expendable item that eventually will wear out and need to be replaced. Replace the head when the following occurs:

- The head surface is torn
- Striking points are no longer detected correctly, even when the head tension is properly adjusted.
- Slack portions remain in the head even after the head tension is properly adjusted.

Replacement heads (optional): MH-8 Mesh Head

1. Remove all tuning bolts and washers.

* Press the lock bushing (in figure below) in place with your finger as you remove each tuning bolt, to prevent the bushings from being pulled off the frame.

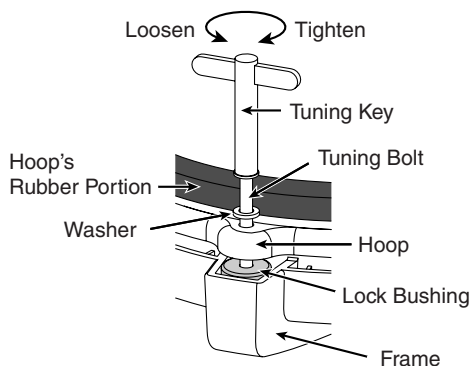

* The lock bushings prevent rotation and loosening of the tuning bolts caused by vibrations that are transmitted from the hoop as you play.

2. Remove the hoop.

3. Remove the old head.

4. Place the new head on the frame.

5. Place the hoop onto the head.

6. Pass the tuning bolts through the washers, then attach them to the hoop and frame.

7. Next, adjust the tension of the head (p. 10).

MEMO

If a lock bushing happens to become separated from the frame while the head is being replaced, position the bushing so its four slots are aligned with the corresponding ridges in the frame, then press down firmly on the bushing.

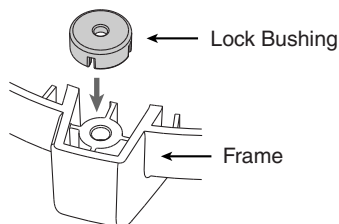

CY-12R/C (V-Cymbal Ride/Crash)

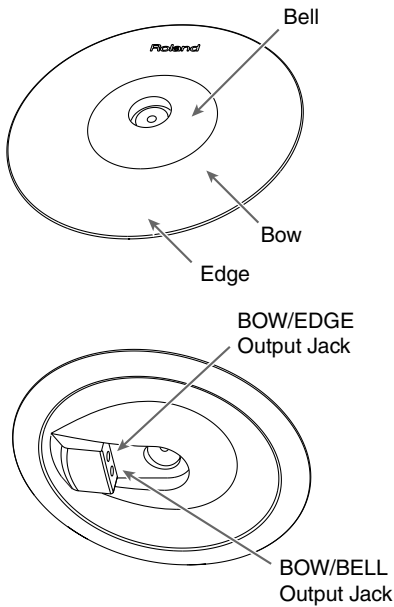

Attaching the V-Cymbal to the Cymbal Mount

1. Remove the wing nut, felt, collar, and washer included with the cymbal mount.
2. Use the tuning key supplied with the VH-11 to tighten the stopper bolt.

The stopper keeps the CY-12R/C from turning, and prevents the cables from catching or getting tangled on the stand.

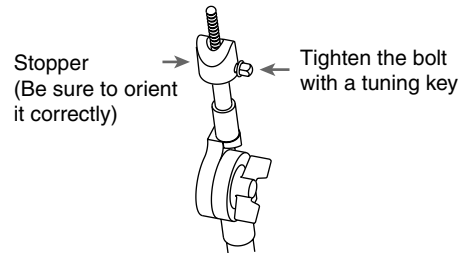

3. Attach the CY-12R/C so the unit is oriented as shown in the diagram (bolt should be opposite the output jacks).

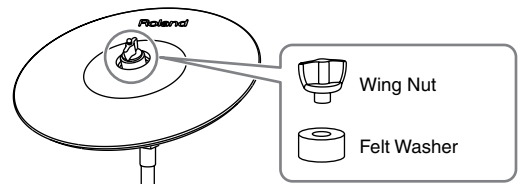

4. Tighten the wing nut to obtain the desired movement.

Use the included felt washer and the wing nut.

NOTE

- Double sounding may occur if the wing nut is loose.
- Do not use the washer or felt included with the cymbal mount.

Assemble the "TD-12K"

Using the built-in connection cables of the MDS-12, connect the pads, cymbals, hi-hat, and kick trigger pad.

NOTE

To prevent malfunction and/or damage to speakers or other devices, always turn down the volume, and turn off the power on all devices before making any connections.

TD-12 Rear Panel

* When connecting the cables, please refer to the marking labels that are attached to both ends of the cables.

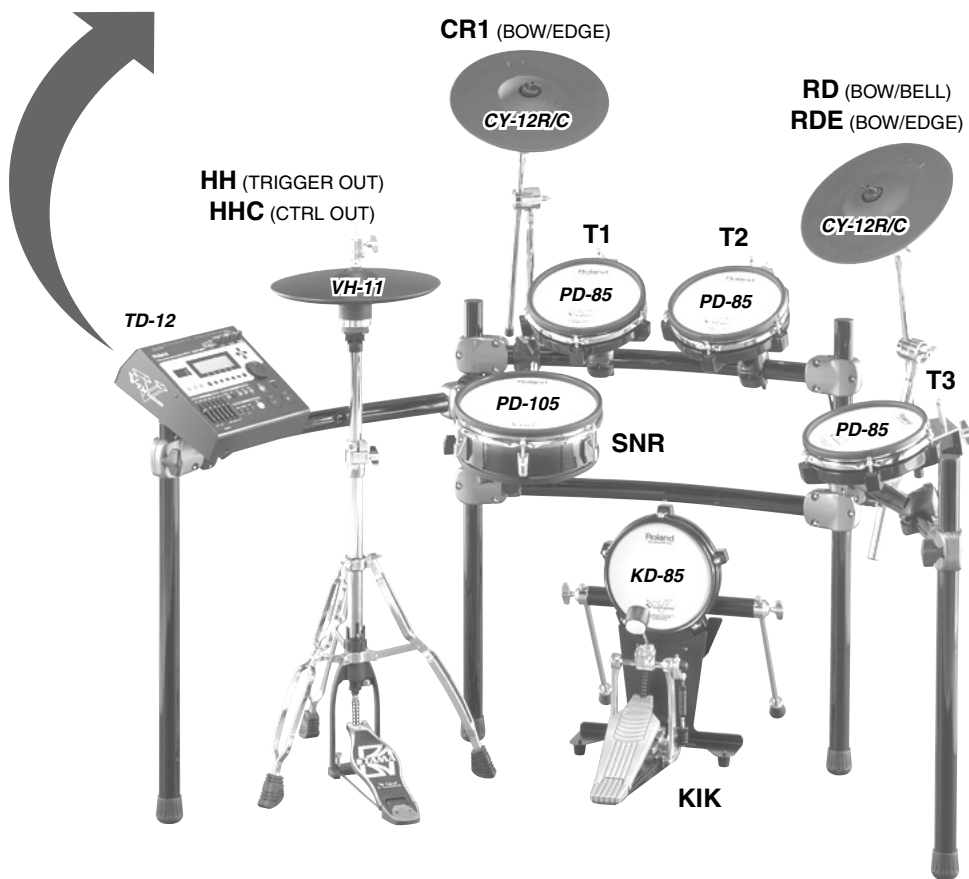
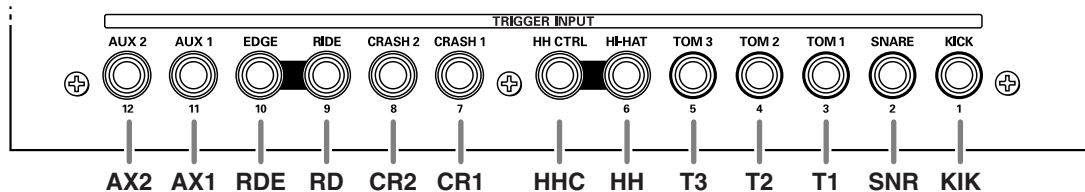

- The HI-HAT and RIDE cymbal use two cables each. See the TD-12 Owner's Manual (p. 20 and p. 52).
- Adjust the VH-11's offset.

* Do not pull or stretch the cables too tight.

The MDS-12 is designed for right-handed drummers.

For left-handed users, the manner in which the pipes should be configured and the way the cables need to be run differ from what appears here, so a proper setup cannot be achieved simply by following this manual. For instructions on setting up the unit for left-handed users, refer to the following:

<http://www.roland.com/products/en/TD-12K/index.html>

Playing the PD-105/PD-85

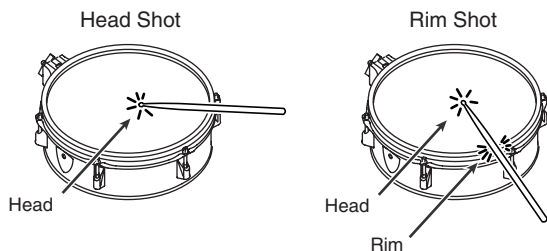

To play the sound assigned to the head, hit only the head.
To play a rim shot, you must **strike both the head and the rim simultaneously**.

MEMO

- If hitting the head produces a rim sound instead, reduce the RimShot Adjust value on the TD-12.
- On the other hand, if you find it difficult to get rim shot sounds to play, raise the RimShot Adjust value.



For details, refer to the TD-12 Owner's Manual (p. 51).

Cross Stick

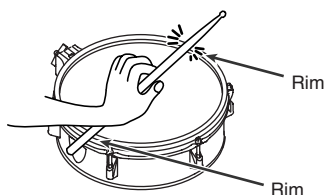

The cross stick sound is sometimes referred to as a "closed rim shot."

When you perform a cross stick, the rim instrument is played. When using the PD-105/85 to play the cross stick, be sure that you **only strike the rim (outer edge) of the pad**. Placing your hand on the head (center area) of the pad might prevent the cross stick sound from being played properly.

Brush Sweep

You can express a sweep sound using brushes (brush sweeps).

- * When using brushes, be sure to use nylon brushes.

MEMO

Cross Stick and Brush Sweep can be used only on the trigger input 2 (SNARE).

Playing the CY-12R/C

Bow Shot

This is the most common playing method, playing the pad face of the cymbal. It corresponds to the sound of the "head-side" of the connected trigger input.

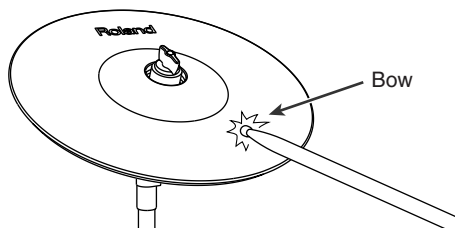

Edge Shot

This playing method involves striking the edge with the shoulder of the stick. It corresponds to the sound of the "rim-side" of the connected trigger input.

- * Edge shots are possible when the connection is made to the BOW/EDGE output.
- * To make use of edge shot, you'll need to connect to a trigger input jack on the percussion sound module that accommodates rim shots.

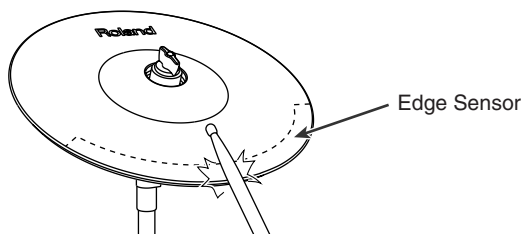

Bell Shot

This playing method involves striking the bell. It corresponds to the sound of the "rim-side" of the connected trigger input.

- * Bell shots are possible when the connection is made to the BOW/BELL output.
- * To make use of bell shot, you'll need to connect to a trigger input jack on the percussion sound module that accommodates rim shots.
- * Strike the bell somewhat strongly with the shoulder of the stick when playing bell shots.

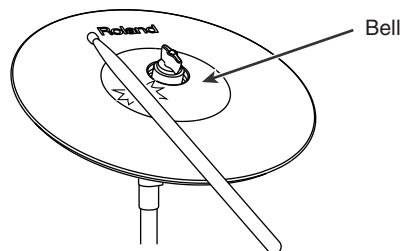

Choking

Choking (pinching) the cymbal's edge with the hand immediately after hitting the cymbal makes the sound stop. Choke the location of the edge sensor shown in the figure. If you choke an area where there is no sensor, the sound does not stop.

* To make use of choking play techniques, you'll need to connect to a trigger input jack on the percussion sound module that accommodates rim shots.

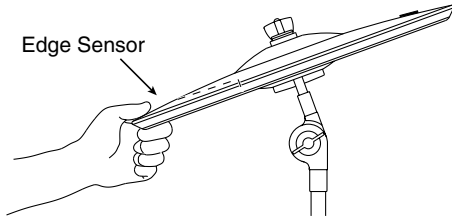

Specifications

KD-85 (V-Kick Trigger Pad)

Pad size:	8 inches
Dimensions:	440 (W) x 340 (D) x 465 (H) mm 17-3/8 (W) x 13-7/16 (D) x 18-5/16 (H) inches
Weight:	4.8 kg 10 lbs 10 oz
Accessory:	Beater
Option:	Mesh Head (MH-8)

PD-105 (V-Pad)

Pad size:	10 inches
Triggers:	2 (Head, Rim)
Dimensions:	280 (W) x 360 (D) x 112 (H) mm 11-1/16 (W) x 14-3/16 (D) x 4-7/16 (H) inches
Weight:	2.3 kg 5 lbs 2 oz
Option:	Mesh Head (MH-10)

PD-85 (V-Pad)

Pad size:	8 inches
Triggers:	2 (Head, Rim)
Dimensions:	245 (W) x 310 (D) x 95 (H) mm 9-11/16 (W) x 12-1/4 (D) x 3-3/4 (H) inches
Weight:	1.7 kg 3 lbs 12 oz
Option:	Mesh Head (MH-8)

CY-12R/C (V-Cymbal Ride/Crash)

Pad size:	12 inches
Triggers:	3 (Bow, Bell, Edge)
Dimensions:	300 (W) x 300 (D) x 51 (H) mm 11-13/16 (W) x 11-13/16 (D) x 2-1/16 (H) inches
Weight:	1.1 kg 2 lbs 7 oz
Accessories:	Stopper, Wing Nut, Felt Washer, Cable Tie

* In the interest of product improvement, the specifications and/or appearance of this unit are subject to change without prior notice.

Information

When you need repair service, call your nearest Roland Service Center or authorized Roland distributor in your country as shown below.

AFRICA

EGYPT
Al Fanny Trading Office
9, EBN Hagar A1 Askalany
Street,
ARD El Golf, Heliopolis,
Cairo 11341, EGYPT
TEL: 20-2-417-1828

REUNION
Maison FO - YAM Marcel
25 Rue Jules Hermann,
Chaudron - BP79 97 491
Ste Clotilde Cedex,
REUNION ISLAND
TEL: (0262) 218-429

SOUTH AFRICA
T.O.M.S. Sound & Music
(Pty)Ltd.
2 ASTRON ROAD DENVER
JOHANNESBURG ZA 2195,
SOUTH AFRICA
TEL: (011)417 3400
FAX: (011)417 3462

Paul Bothner(PTY)Ltd.
Royal Cape Park, Unit 24
Londonderry Road, Ottery 7800
Cape Town, SOUTH AFRICA
TEL: (021) 799 4900

ASIA

CHINA
Roland Shanghai Electronics
Co.,Ltd.
5F. No.1500 Pingliang Road
Shanghai 200090, CHINA
TEL: (021) 5580-0800

Roland Shanghai Electronics
Co.,Ltd.
(BEIJING OFFICE)
10F. No.18 3 Section Anhuaxili
Chaoyang District Beijing
100011 CHINA
TEL: (010) 6426-0500

HONG KONG
Tom Lee Music Co., Ltd.
Service Division
22-32 Pun Shan Street, Tsuen
Wan, New Territories,
HONG KONG
TEL: 2415 0911

Parsons Music Ltd.
8th Floor, Railway Plaza, 39
Chatham Road South, T.S.T,
Kowloon, HONG KONG
TEL: 2333 1863

INDIA
Rivera Digitec (India) Pvt. Ltd.
409, Nirman Kendra
Mahalaxmi Flats Compound
Off. Dr. Edwin Moses Road,
Mumbai-400011, INDIA
TEL: (022) 2493 9051

INDONESIA
PT Citra Inti Rama
Jl. Cideng Timur No. 15J-150
Jakarta Pusat
INDONESIA
TEL: (021) 6324170

KOREA
Cosmos Corporation
1461-9, Seocho-Dong,
Seocho Ku, Seoul, KOREA
TEL: (02) 3486-8855

MALAYSIA
Roland Asia Pacific Sdn. Bhd.
45-1, Block C2, Jalan PJU 1/39,
Dataran Prima, 47301 Petaling
Jaya, Selangor, MALAYSIA
TEL: (03) 7805-3263

PHILIPPINES
G.A. Yupangco & Co. Inc.
339 Gil J. Puyat Avenue
Makati, Metro Manila 1200,
PHILIPPINES
TEL: (02) 899 9801

SINGAPORE
SWEET LEE MUSIC
COMPANY PTE. LTD.
150 Sims Drive,
SINGAPORE 387381
TEL: 6846-3676

TAIWAN
ROLAND TAIWAN
ENTERPRISE CO., LTD.
Room 5, 9th. No. 112 Chung
Shan N.Road Sec.2, Taipei,
TAIWAN, R.O.C.
TEL: (02) 2561 3339

THAILAND
Theera Music Co., Ltd.
330 Soi Vergn NakornKasem,
New Road, Sumpantawongse,
Bangkok 10100, THAILAND
TEL: (02) 224-8821

AUSTRALIA/ NEW ZEALAND

**AUSTRALIA/
NEW ZEALAND**
Roland Corporation
Australia Pty.,Ltd.
38 Campbell Avenue
Dee Why West. NSW 2099
AUSTRALIA

For Australia
Tel: (02) 9982 8266
For New Zealand
Tel: (09) 3098 715

CENTRAL/LATIN AMERICA

ARGENTINA
Instrumentos Musicales S.A.
Av.Santa Fe 2055
(1129) Buenos Aires
ARGENTINA
TEL: (011) 4508-2700

BARBADOS
A&B Music Supplies LTD
12 Webster Industrial Park
Wilkey, St.Michael, Barbados
TEL: (246)430-1100

BRAZIL
Roland Brasil Ltda.
Rua San Jose, 780 Sala B
Parque Industrial San Jose
Cotia - Sao Paulo - SP, BRAZIL
TEL: (011) 4615 5666

CHILE
Comercial Fancy II S.A.
Rut.: 96.919.420-1
Nataliel Cox #739, 4th Floor
Santiago - Centro, CHILE
TEL: (021) 688-9540

COLOMBIA
Centro Musical Ltda.
Cra 43 B No 25 A 41 Bodega 9
Medellin, Colombia
TEL: (574)812529

COSTA RICA
JUAN Bansbach Instrumentos
Musicales
Ave.1. Calle 11, Apartado
10237,
San Jose, COSTA RICA
TEL: 258-0211

CURACAO
Zeelandia Music Center Inc.
Orionweg 30
Curacao, Netherland Antilles
TEL:(305)5926866

DOMINICAN REPUBLIC
Instrumentos Fernando Giraldez
Calle Proyecto Central No.3
Ens.La Esperilla
San Domingo,
Dominican Republic
TEL:(809) 683 0305

ECUADOR
Mas Musika
Rumichaca 822 y Zaruma
Guayaquil - Ecuador
TEL:(593-4)2302364

EL SALVADOR
OMNI MUSIC
75 Avenida Norte y Final
Alameda Juan Pablo II,
Edificio No.4010 San Salvador,
EL SALVADOR
TEL: 262-0788

GUATEMALA
Casa Instrumental
Calzada Roosevelt 34-01, zona 11
Ciudad de Guatemala
Guatemala
TEL:(502) 599-2888

HONDURAS
Almacen Pajaro AZUL S.A. de C.V.
BO.Paz Barahona
3 Ave.11 Calle S.O
San Pedro Sula, Honduras
TEL: (504) 553-2029

MARTINIQUE
Musique & Son
Z.I.Les Mangle
97232 Le Lamantin
Martinique F.W.I.
TEL: 596 596 426860

Gigamusik SARL
10 Rue De La Folie
97200 Fort De France
Martinique F.W.I.
TEL: 596 596 715222

MEXICO
Casa Veerkamp, s.a. de c.v.
Av. Toluca No. 323, Col. Olivar
de los Padres 01780 Mexico
D.F. MEXICO
TEL: (55) 5668-6699

NICARAGUA
Bansbach Instrumentos
Musicales Nicaragua
Altamira D'Este Calle Principal
de la Farmacia Sta.Avenida
1 Cuadra al Lago.#503
Managua, Nicaragua
TEL: (505)277-2557

PANAMA
SUPRO MUNDIAL, S.A.
Boulevard Andrews, Albrook,
Panama City, REP. DE
PANAMA
TEL: 315-0101

PARAGUAY
Distribuidora De
Instrumentos Musicales
J.E. Olear y ESC. Manduivira
Asuncion PARAGUAY
TEL: (595) 21 492147

PERU
Audionet
Distribuciones Musicales SAC
Juan Fanning 530
Miraflores
Lima - Peru
TEL: (511) 4461388

TRINIDAD
AMR Ltd
Ground Floor
Maritime Plaza
Barataria Trinidad W.I.
TEL: (868) 638 6385

URUGUAY
Todo Musica S.A.
Francisco Acuna de Figueroa
1771
C.P.: 11.800
Montevideo, URUGUAY
TEL: (02) 924-2335

VENEZUELA
Instrumentos Musicales
Allegro.C.A.
Av.las industrias edf.Guitar
import
#7 zona Industrial de Turumo
Caracas, Venezuela
TEL: (212) 244-1122

EUROPE

AUSTRIA
Roland Elektronische
Musikinstrumente HmbH.
Austrian Office
Eduard-Bodem-Gasse 8,
A-6020 Innsbruck, AUSTRIA
TEL: (0262) 26 44 260

**BELGIUM/FRANCE/
HOLLAND/
LUXEMBOURG**
Roland Central Europe N.V.
Houtstraat 3, B-2260, Oevel
(Westerlo) BELGIUM
TEL: (014) 575811

CROATIA
ART-CENTAR
Degenova 3,
HR - 10000 Zagreb
TEL: (1) 466 8493

CZECH REP.
CZECH REPUBLIC
DISTRIBUTOR s.r.o
Voctarova 247 /16
CZ - 180 00 PRAHA 8,
CZECH REP.
TEL: (2) 830 20270

DENMARK
Roland Scandinavia A/S
Nordhavnsvej 7, Postbox 880,
DK-2100 Copenhagen
DENMARK
TEL: 3916 6200

FINLAND
Roland Scandinavia As, Filial
Finland
Elmientie 5
FIN-01510 Vantaa, FINLAND
TEL: (09) 68 24 020

GERMANY
Roland Elektronische
Musikinstrumente HmbH.
Oststrasse 96, 22844
Norderstedt, GERMANY
TEL: (040) 52 60090

GREECE/CYPRUS
STOLLAS S.A.
Musik Sound Light
155, New National Road
Patras 26442, GREECE
TEL: 2610 435400

HUNGARY
Roland East Europe Ltd.
Warehouse Area "DEPO" Pf83
H-2046 Torokbalint,
HUNGARY
TEL: (23) 511011

IRELAND
Roland Ireland
G2 Calmout Park, Calmout
Avenue, Dublin 12
Republic of IRELAND
TEL: (01) 4294444

ITALY
Roland Italy S. p. A.
Viale delle Industrie 8,
20020 Arese, Milano, ITALY
TEL: (02) 937-78300

NORWAY
Roland Scandinavia Awd.
Kontor Norge
Lilleakerveien 2 Postboks 95
Lilleaker N-0216 Oslo
NORWAY
TEL: 2273 0074

POLAND
ROLAND POLSKA SP. Z O.O.
Ul. Gibraltaraska 4,
PL-03 664 Warszawa
POLAND
TEL: (022) 679 4419

PORTUGAL
Roland Iberia, S.L.
Portugal Office
Caís das Pedras, 8/9-1 Dto
4050-465, Porto, PORTUGAL
TEL: 22 608 00 60

ROMANIA
FBS LINES
Piata Libertatii 1,
53500 Gheorgheni,
ROMANIA
TEL: (266) 364 609

RUSSIA
MuTek
Dorozhnaya ul.3, korp.6
117 545 Moscow, RUSSIA
TEL: (095) 981-4967

SLOVAKIA
DAN Acoustic s.r.o.
Povazská 18,
SK - 940 01 Nové Zámky
TEL: (035) 6424 330

SPAIN
Roland Iberia, S.L.
Paseo Garcia Faria, 33-35
08005 Barcelona SPAIN
TEL: 93 493 91 00

SWEDEN
Roland Scandinavia A/S
SWEDISH SALES OFFICE
Danvik Center 28, 2 tr.
S-131 30 Nacka SWEDEEN
TEL: (08) 702 00 20

SWITZERLAND
Roland (Switzerland) AG
Landstrasse 5, Postfach,
CH-4452 Ittingen,
SWITZERLAND
TEL: (061) 927-8383

UKRAINE
EURHYTHMICS Ltd.
P.O.Box: 37-aa,
Nedeczej Str. 30
UA - 89600 Mukachevo,
UKRAINE
TEL: (03131) 414-40

UNITED KINGDOM
Roland (U.K.) Ltd.
Atlantic Close, Swansea
Enterprise Park, SWANSEA
SA7 9FJ,
UNITED KINGDOM
TEL: (01792) 702701

MIDDLE EAST

BAHRAIN
Moon Stores
No.16, Bab Al Bahrain Avenue,
P.O.Box 247, Manama 304,
State of BAHRAIN
TEL: 17 211 005

IRAN
MOCO INC.
No.41 Nike St., Dr.Shariyati Ave.,
Roberoy Cerahie Mirdamad
Tehran, IRAN
TEL: (021) 285-4169

ISRAEL
Halilit P. Greenspoon & Sons
Ltd.
8 Retzif Ha'aliya Hashnya St.
Tel-Aviv-Yafo ISRAEL
TEL: (03) 6823666

JORDAN
MUSIC HOUSE CO. LTD.
FREDDY FOR MUSIC
P. O. Box 922846
Amman 11192 JORDAN
TEL: (06) 5692696

KUWAIT
EASA HUSAIN AL-YOUSIFI
& SONS CO.
Abdullah Salem Street,
Safat, KUWAIT
TEL: 243-6399

LEBANON
Chahine S.A.L.
Gerge Zeidan St., Chahine
Bldg., Achrafieh, P.O.Box: 16-
5857,
Beirut, LEBANON
TEL: (01) 20-1441

OMAN
TALENT CENTRE L.L.C.
Malatan House No.1
Al Noor Street, Ruwi
SULTANATE OF OMAN
TEL: 2478 3443

QATAR
Al Emadi Co. (Badie Studio &
Stores)
P.O. Box 62, Doha, QATAR
TEL: 4423-554

SAUDI ARABIA
aDawlah Arabia
Electronics APL
Corniche Road, Aldossary
Blgd., 1st Floor, Alkhobar,
SAUDI ARABIA

P.O.Box 2154, Alkhubar 31952
SAUDI ARABIA
TEL: (03) 898 2081

SYRIA
Technical Light & Sound
Center
Rawda, Abdul Qader Zajaziri St.
Bldg. No. 21, P.O.BOX 13520,
Damascus, SYRIA
TEL: (011) 223-5384

TURKEY
ZUHAL DIS TICARET A.S.
Galip Dede Cad. No.37
Beyoglu - Istanbul / TURKEY
TEL: (0212) 249 85 10

U.A.E.
Zak Electronics & Musical
Instruments Co. L.L.C.
Zabeel Road, Al Sheroq Bldg.,
No. 14, Grand Floor, Dubai,
U.A.E.
TEL: (04) 3360715

NORTH AMERICA

CANADA
Roland Canada Ltd.
(Head Office)
5480 Parkwood Way
Richmond B.C., V6V 2M4
CANADA
TEL: (604) 270 6626

Roland Canada Ltd.
(Toronto Office)
170 Admiral Boulevard
Mississauga On L5T 2N6
CANADA
TEL: (905) 362 9707

U. S. A.
Roland Corporation U.S.
5100 S. Eastern Avenue
Los Angeles, CA 90040-2938,
U. S. A.
TEL: (323) 890 3700



This product must be disposed of separately at your local waste recycling centre. Do not dispose of in household waste bin.



As of November 1, 2006 (ROLAND)