

Roland®

SRQ-4015



Owner's Manual

Before using this unit, carefully read the sections entitled: "IMPORTANT SAFETY INSTRUCTIONS" (p. 2), "USING THE UNIT SAFELY" (p. 3, 4), and "IMPORTANT NOTES" (p. 5). These sections provide important information concerning the proper operation of the unit. Additionally, in order to feel assured that you have gained a good grasp of every feature provided by your new unit, owner's manual should be read in its entirety. The manual should be saved and kept on hand as a convenient reference.

The explanations in this manual include illustrations that depict what should typically be shown on the display. Note, however, that your unit may incorporate a newer, enhanced version of the system (e.g., includes newer sounds), so what you actually see in the display may not always match what appears in the manual.

Copyright © 2000 ROLAND CORPORATION

All rights reserved. No part of this publication may be reproduced in any form without the written permission of ROLAND CORPORATION.

	CAUTION RISK OF ELECTRIC SHOCK DO NOT OPEN	
ATTENTION : RISQUE DE CHOC ELECTRIQUE NE PAS OUVRIR		
CAUTION: TO REDUCE THE RISK OF ELECTRIC SHOCK, DO NOT REMOVE COVER (OR BACK). NO USER-SERVICEABLE PARTS INSIDE. REFER SERVICING TO QUALIFIED SERVICE PERSONNEL.		



The lightning flash with arrowhead symbol, within an equilateral triangle, is intended to alert the user to the presence of uninsulated "dangerous voltage" within the product's enclosure that may be of sufficient magnitude to constitute a risk of electric shock to persons.



The exclamation point within an equilateral triangle is intended to alert the user to the presence of important operating and maintenance (servicing) instructions in the literature accompanying the product.

INSTRUCTIONS PERTAINING TO A RISK OF FIRE, ELECTRIC SHOCK, OR INJURY TO PERSONS.

IMPORTANT SAFETY INSTRUCTIONS SAVE THESE INSTRUCTIONS

WARNING - When using electric products, basic precautions should always be followed, including the following:

1. Read these instructions.
2. Keep these instructions.
3. Heed all warnings.
4. Follow all instructions.
5. Do not use this apparatus near water.
6. Clean only with a damp cloth.
7. Do not block any of the ventilation openings. Install in accordance with the manufacturers instructions.
8. Do not install near any heat sources such as radiators, heat registers, stoves, or other apparatus (including amplifiers) that produce heat.
9. Do not defeat the safety purpose of the polarized or grounding-type plug. A polarized plug has two blades with one wider than the other. A grounding type plug has two blades and a third grounding prong. The wide blade or the third prong are provided for your safety. When the provided plug does not fit into your outlet, consult an electrician for replacement of the obsolete outlet.
10. Protect the power cord from being walked on or pinched particularly at plugs, convenience receptacles, and the point where they exit from the apparatus.
11. Only use attachments/accessories specified by the manufacturer.
12. Never use with a cart, stand, tripod, bracket, or table except as specified by the manufacturer, or sold with the apparatus. When a cart is used, use caution when moving the cart/apparatus combination to avoid injury from tip-over.
13. Unplug this apparatus during lightning storms or when unused for long periods of time.
14. Refer all servicing to qualified service personnel. Servicing is required when the apparatus has been damaged in any way, such as power-supply cord or plug is damaged, liquid has been spilled or objects have fallen into the apparatus, the apparatus has been exposed to rain or moisture, does not operate normally, or has been dropped.



For the U.K.

IMPORTANT: THE WIRES IN THIS MAINS LEAD ARE COLOURED IN ACCORDANCE WITH THE FOLLOWING CODE.



BLUE: NEUTRAL
BROWN: LIVE

As the colours of the wires in the mains lead of this apparatus may not correspond with the coloured markings identifying the terminals in your plug, proceed as follows:
 The wire which is coloured BLUE must be connected to the terminal which is marked with the letter N or coloured BLACK.
 The wire which is coloured BROWN must be connected to the terminal which is marked with the letter L or coloured RED.
 Under no circumstances must either of the above wires be connected to the earth terminal of a three pin plug.







USING THE UNIT SAFELY

INSTRUCTIONS FOR THE PREVENTION OF FIRE, ELECTRIC SHOCK, OR INJURY TO PERSONS

About WARNING and CAUTION Notices







 WARNING	Used for instructions intended to alert the user to the risk of death or severe injury should the unit be used improperly.
 CAUTION	Used for instructions intended to alert the user to the risk of injury or material damage should the unit be used improperly. * Material damage refers to damage or other adverse effects caused with respect to the home and all its furnishings, as well to domestic animals or pets.

About the Symbols







	The  symbol alerts the user to important instructions or warnings. The specific meaning of the symbol is determined by the design contained within the triangle. In the case of the symbol at left, it is used for general cautions, warnings, or alerts to danger.
	The  symbol alerts the user to items that must never be carried out (are forbidden). The specific thing that must not be done is indicated by the design contained within the circle. In the case of the symbol at left, it means that the unit must never be disassembled.
	The  symbol alerts the user to things that must be carried out. The specific thing that must be done is indicated by the design contained within the circle. In the case of the symbol at left, it means that the power-cord plug must be unplugged from the outlet.

ALWAYS OBSERVE THE FOLLOWING



WARNING

- Before using this unit, make sure to read the instructions below, and the Owner's Manual. 
- Do not open or perform any internal modifications on the unit. 
- Do not attempt to repair the unit, or replace parts within it (except when this manual provides specific instructions directing you to do so). Refer all servicing to your retailer, the nearest Roland Service Center, or an authorized Roland distributor, as listed on the "Information" page. 
- Never use or store the unit in places that are:
 - Subject to temperature extremes (e.g., direct sunlight in an enclosed vehicle, near a heating duct, on top of heat-generating equipment); or are 
 - Damp (e.g., baths, washrooms, on wet floors); or are 
 - Humid; or are
 - Exposed to rain; or are
 - Dusty; or are
 - Subject to high levels of vibration.
- This unit should be used only with a rack or stand that is recommended by Roland. 
- When using the unit with a rack or stand recommended by Roland, the rack or stand must be carefully placed so it is level and sure to remain stable. If not using a rack or stand, you still need to make sure that any location you choose for placing the unit provides a level surface that will properly support the unit, and keep it from wobbling. 









WARNING

- The unit should be connected to a power supply only of the type described in the operating instructions, or as marked on the unit. 
- Do not excessively twist or bend the power cord, nor place heavy objects on it. Doing so can damage the cord, producing severed elements and short circuits. Damaged cords are fire and shock hazards! 
- This unit, either alone or in combination with an amplifier and headphones or speakers, may be capable of producing sound levels that could cause permanent hearing loss. Do not operate for a long period of time at a high volume level, or at a level that is uncomfortable. If you experience any hearing loss or ringing in the ears, you should immediately stop using the unit, and consult an audiologist. 
- Do not allow any objects (e.g., flammable material, coins, pins); or liquids of any kind (water, soft drinks, etc.) to penetrate the unit. 

- In households with small children, an adult should provide supervision until the child is capable of following all the rules essential for the safe operation of the unit. 
- Protect the unit from strong impact. (Do not drop it!) 

⚠ WARNING

- Do not force the unit's power-supply cord to share an outlet with an unreasonable number of other devices. Be especially careful when using extension cords—the total power used by all devices you have connected to the extension cord's outlet must never exceed the power rating (watts/amperes) for the extension cord. Excessive loads can cause the insulation on the cord to heat up and eventually melt through. 
- Before using the unit in a foreign country, consult with your retailer, the nearest Roland Service Center, or an authorized Roland distributor, as listed on the "Information" page. 

⚠ CAUTION

- The unit should be located so that its location or position does not interfere with its proper ventilation. 
- Always grasp only the plug on the power-supply cord when plugging into, or unplugging from, an outlet or this unit. 
- Try to prevent cords and cables from becoming entangled. Also, all cords and cables should be placed so they are out of the reach of children. 
- Never climb on top of, nor place heavy objects on the unit. 
- Never handle the power cord or its plugs with wet hands when plugging into, or unplugging from, an outlet or this unit. 
- Before moving the unit, disconnect the power plug from the outlet, and pull out all cords from external devices. 
- Before cleaning the unit, turn off the power and unplug the power cord from the outlet. 
- Whenever you suspect the possibility of lightning in your area, pull the plug on the power cord out of the outlet. 

IMPORTANT NOTES

In addition to the items listed under "IMPORTANT SAFETY INSTRUCTIONS" and "USING THE UNIT SAFELY" on pages 2 and 3, please read and observe the following:

Power Supply

- Do not use this unit on the same power circuit with any device that will generate line noise (such as an electric motor or variable lighting system).
- Before connecting this unit to other devices, turn off the power to all units. This will help prevent malfunctions and/or damage to speakers or other devices.

Placement

- Using the unit near power amplifiers (or other equipment containing large power transformers) may induce hum. To alleviate the problem, change the orientation of this unit; or move it farther away from the source of interference.
- This device may interfere with radio and television reception. Do not use this device in the vicinity of such receivers.
- To avoid possible breakdown, do not use the unit in a wet area, such as an area exposed to rain or other moisture.

Maintenance

- For everyday cleaning wipe the unit with a soft, dry cloth or one that has been slightly dampened with water. To remove stubborn dirt, use a cloth impregnated with a mild, non-abrasive detergent. Afterwards, be sure to wipe the unit thoroughly with a soft, dry cloth.
- Never use benzine, thinners, alcohol or solvents of any kind, to avoid the possibility of discoloration and/or deformation.

Additional Precautions

- Please be aware that the contents of memory can be irretrievably lost as a result of a malfunction, or the improper operation of the unit. To protect yourself against the risk of losing important data, we recommend that you periodically save a backup copy of important data you have stored in the unit's memory in another MIDI device (e.g., a sequencer).
- Unfortunately, it may be impossible to restore the contents of data that was stored in another MIDI device (e.g., a sequencer) once it has been lost. Roland Corporation assumes no liability concerning such loss of data.

- Use a reasonable amount of care when using the unit's buttons, sliders, or other controls; and when using its jacks and connectors. Rough handling can lead to malfunctions.
- Never strike or apply strong pressure to the display.
- When connecting / disconnecting all cables, grasp the connector itself—never pull on the cable. This way you will avoid causing shorts, or damage to the cable's internal elements.
- A small amount of heat will radiate from the unit during normal operation.
- To avoid disturbing your neighbors, try to keep the unit's volume at reasonable levels (especially when it is late at night).
- When you need to transport the unit, package it in the box (including padding) that it came in, if possible. Otherwise, you will need to use equivalent packaging materials.
- Use a cable from Roland to make the connection. If using some other make of connection cable, please note the following precautions.
 - Some connection cables contain resistors. Do not use cables that incorporate resistors for connecting to this unit. The use of such cables can cause the sound level to be extremely low, or impossible to hear. For information on cable specifications, contact the manufacturer of the cable.

Table of Contents

USING THE UNIT SAFELY	3
IMPORTANT NOTES	5
Table of Contents	6
Features	7
Front and Rear Panel	8
Front Panel	8
Rear Panel	8
LCD Display	8
Basic Operations	9
Before You Begin	9
Connections	10
Turning On the Power	13
To Set the Input and Output Level	14
Internal Signal Flow	14
Setting the Input Level	14
Setting the Output Level (OUTPUT)	14
Changing the Input/Output Routing (INPUT SELECT)	15
To Let the Signals Bypass the Effect (BYPASS)	16
To Disable the Controls (LOCK)	16
Locking the Controls	16
Unlocking the Controls	16
Setting the Lock Function Level	17
To Edit System Parameters	17
Setting the Gain Level Controlling Range By Steps (STEP GAIN)	17
Readjusting the Frequency slider (CALIBRATION)	18
Adjusting the Contrast of the Display (LCD CONTRAST)	19
Changing How Things Are Displayed (GAIN SYMBOL)	19
Adjusting the Output Level (OUTPUT)	20
Link Function (LINK)	20
Noise Gate (NOISE GATE)	20
Time Alignment (TIME ALIGNEMENT)	20
Lock Function (LOCK)	20
Morphing (MORPHING)	20
Foot Switch (FOOT SWITCH)	20
MIDI	20
To Select Channels	21
Setting Each Channel	21
Adjusting the EQ Settings for CH1, 2 or CH3, 4 at the Same Time (LINK)	21
Linking Both Channels	21
Selecting the Link Type	22
Copying the Settings of One Channel to the Other	22

Sound Creation	23
Adjusting the Tone (Editing the Graphic Equalizer)	23
Normal Use of the Equalizer	23
About the Play Mode	23
Setting the Entire Gain Level Back to 0 dB (FLAT)	24
Detecting the Feedback Point (SEARCH)	24
Drawing an Easy EQ Curve Line (SWEEP)	26
Simultaneously Adjusting A Wide Range Of Adjacent Bands (WIDE)	26
Smoothing the Transition Between Memories (MORPHING)	27
To Cut the Gain of Selected Frequencies to -60dB (TOTAL CUT)	28
Reducing the Remaining Noise (NOISE GATE)	29
To Refine the Time Lag Between Channel Outputs (TIME ALIGNMENT)	30
To Recover the Settings (UNDO/REDO)	30
To Store/Recall the Present Settings (MEMORY SAVE/LOAD)	31
To Store the Current Settings (MEMORY SAVE)	31
To Recall the Stored Settings (MEMORY LOAD)	32
Remote Control	33
Using A Foot Switch	33
To Let the Signals Bypass the Effect (BYPASS)	33
Recalling Memorized Settings in Turns (MEMORY ROTATION)	33
Use With MIDI Devices	34
About MIDI	34
Changing settings from External MIDI Devices	35
Sending and Receiving Settings Via MIDI (BULK DUMP/LOAD)	37
Reference	40
Troubleshooting	40
There is No Sound or the Sound is Too Low	40
The Sound is Distorted	40
MIDI Messages Are Not Being Received	40
Display Messages	40
Equalizer Characteristics	41
User Interface Guide	42
MIDI Implementation Chart	43
Block Diagram	44
Specification	45
Index	46

Features

Low-Noise, High-Quality Sounds (24bit AD/DA)

With the 24-bit AD/DA converter, this unit provides low-noise, high-quality sounds.

Easy Operation

The Frequency slider and dial encoder ensure simple and quick analog-like command of this unit.

Noise Gate Function

Cuts the noise that enters as a mixture with input signals heard at soundless points. The 24-bit AD/DA converter ensures overall noise reduction with this unit, and also reduces noise from external sources (p. 29).

Time Alignment Function

In a system consisting of multiple speakers, the Time Alignment (delay) function allows you to correct for the negative effects on sound quality that can occur as the result of the differences in the amount of time it takes for sound to arrive from the various speakers. In addition to the delay time, the distance is indicated in the display, which should make it easier to quickly perform onsite adjustments (p. 30).

“Wide” Function Allows Control of Multiple Bands

The Wide function enables you to control a desired range of frequencies simultaneously at scenes where easy and quick equalizing is required (p. 26).

Search Function

Simply by moving the Frequency slider, you can carry out equalization much like you can with a parametric EQ. This comes in handy when you want to do things such as find the point where feedback occurs, or find that sweet spot (p. 24).

Flat Function

You can reset the EQ curve line into a flat position (p. 24).

Link Function

By linking CH1 and CH2, or CH3 and CH4, you can control two channels simultaneously (p. 21).

16 User Memory Bank

You can recall up to 16 memorized programs at certain scenes, and also compare several EQ settings with a touch of a button (p. 31).

15 Bands x 4 Channels in a 1U Size Unit

Bypass Control with a Foot switch (p. 33)

Front and Rear Panel

Front Panel

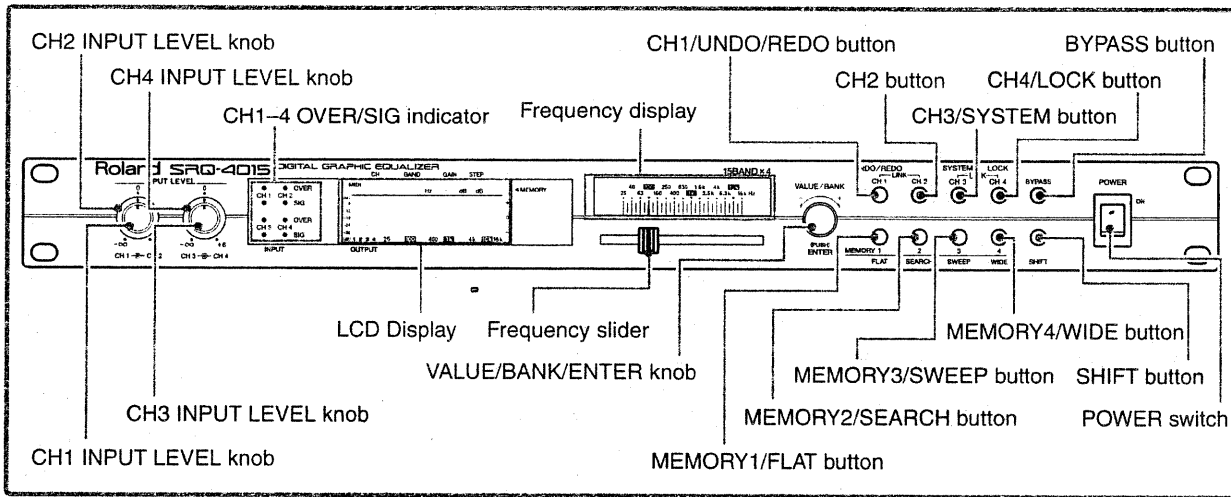

Rear Panel

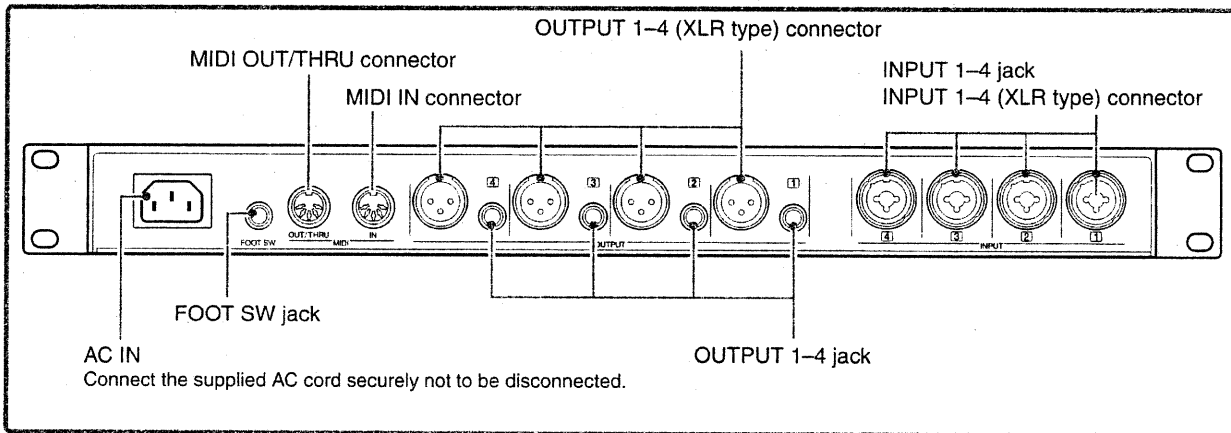

LCD Display

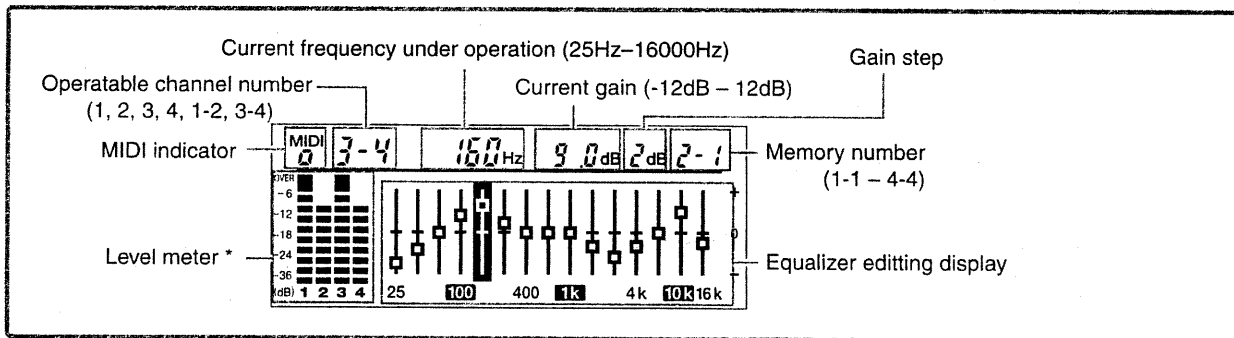

* The Level Meter shows the output level of the EQ setting (p. 14).

Basic Operations

Before You Begin

Do the necessary preparations before you start operations.



- If you are using this unit alone, attach the supplied rubber stand to the bottom.
- Use the washers included with the unit when rack-mounting the unit.

Notes on making the connections

When making connections, be sure to observe these precautions. Otherwise, you risk malfunction and/or damage to other connected equipment.

- To prevent malfunction and/or damage to speakers or other devices, always turn down the volume, and turn off the power on all devices before making any connections.
- Do not connect the SRQ-4015 to the output of a power amplifier.
- The pin assignment for the XLR type connectors (input) is as shown below. Before making any connections, make sure that this pin assignment is compatible with that of all your other devices.

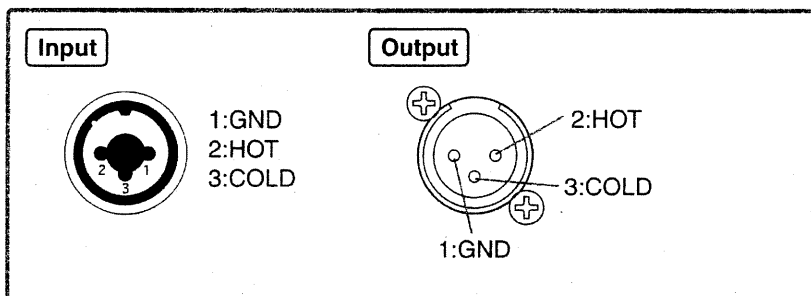

- The phone jacks support balanced input/output using TRS standard stereo plugs. (Also accepts unbalanced input.)

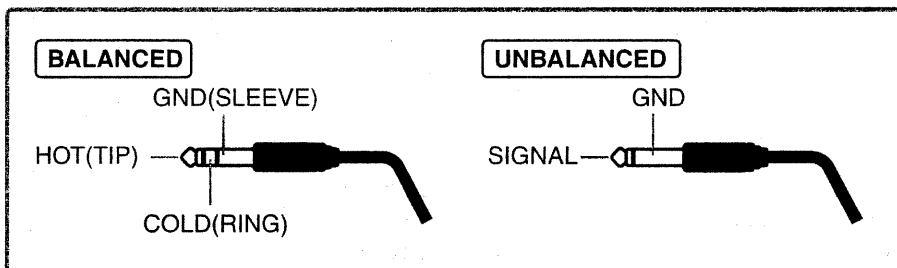

Do not connect to an XLR connector and a TRS plug at the same time.

Basic Operations

Connections

The SRQ-4015 can be connected up in various ways depending on how it is to be used. Refer to the example setups that are given in the following.

Using with an Entire PA System

This is an example of a connection that uses the SRQ-4015 for processing sound equalizing to all devices that are connected to the mixing console. You can adjust the tone of the total output sound.

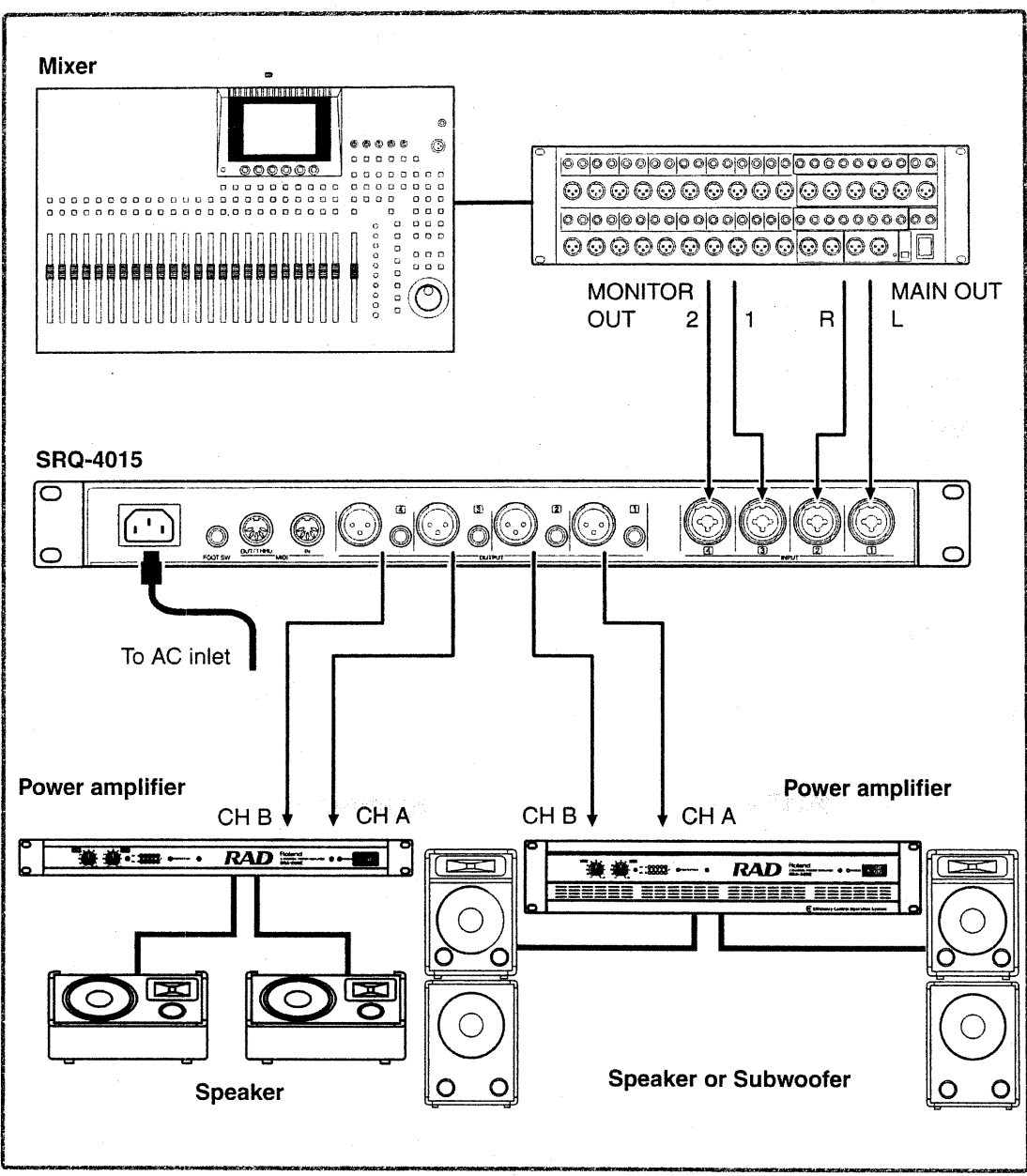

Basic Operations

If you change the internal signal routing (p. 15), signals that have been input on two channels can be output on four channels.

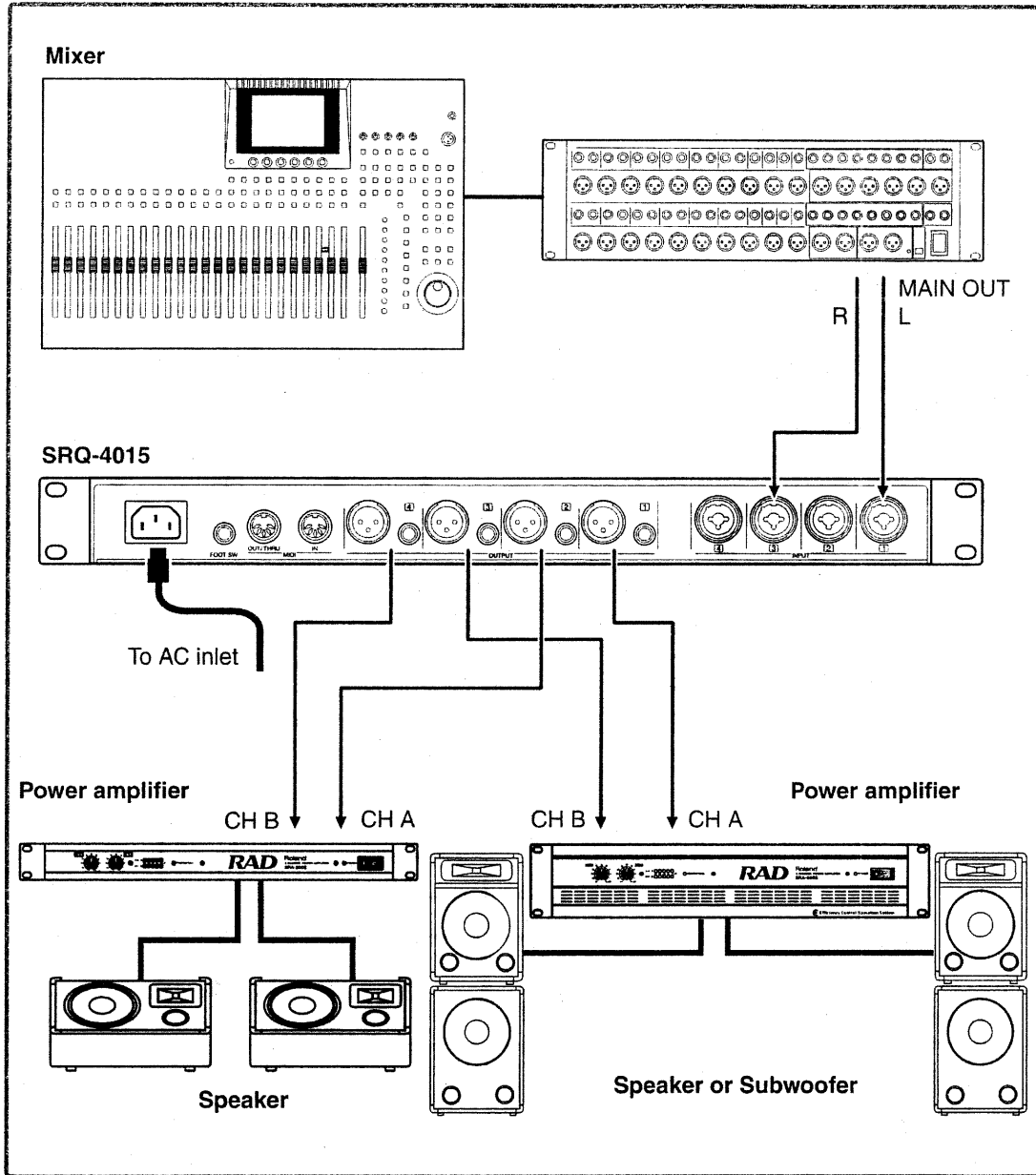

Basic Operations



A variety of other connections, such as outputting on four channels a signal that's been input in monaural, are also possible. For details, see "Changing the Input/Output Routing" (p. 15).

Basic Operations

Using With a Specific Microphone or Instrument

This is an example of a connection that uses the SRQ-4015 with only a specific microphone or instrument. When the SRQ-4015 for a microphone, connect the microphone to a channel insertion on a mixer.

Inserting on a Mixing Channel

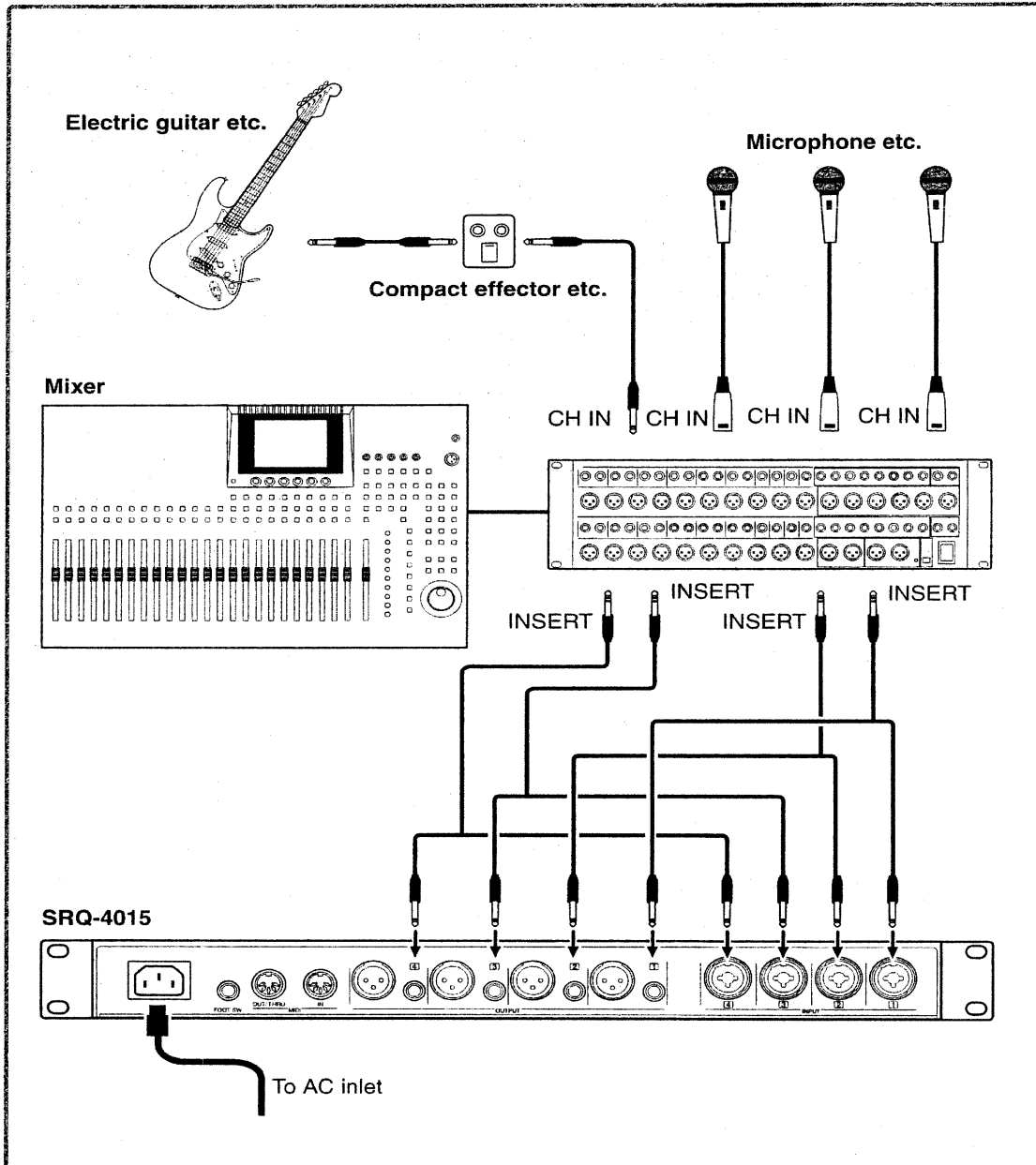

When connecting the cables, be sure to use the specified cables for your mixer.

Connecting External Devices

You can remotely control some of the functions of the SRQ-4015 using a connected foot switch (p. 33).

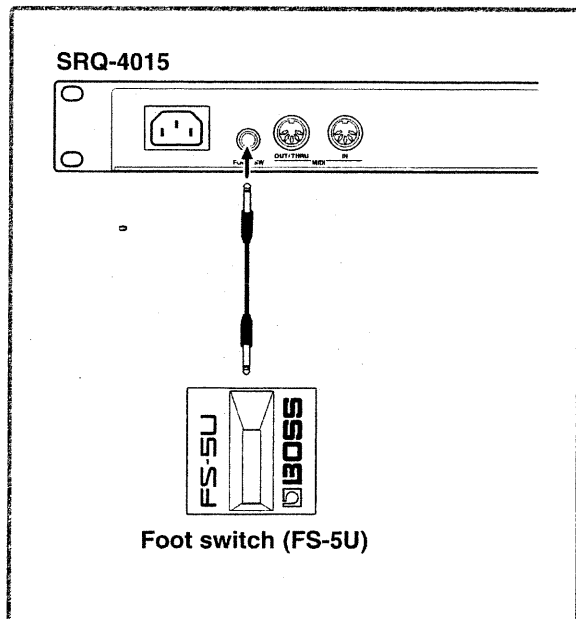

- When connecting a foot switch (FS-5U; sold separately) to the FOOT SW jack, set the polarity switch as shown below.

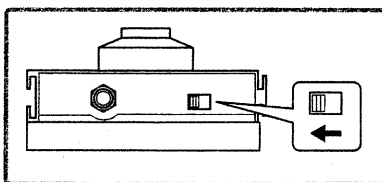

Turning On the Power

Once the connections have been completed (p. 10), turn on the power to your various devices in the order specified. By turning on devices in the wrong order, you risk causing malfunction and/or damage to speakers and other devices.

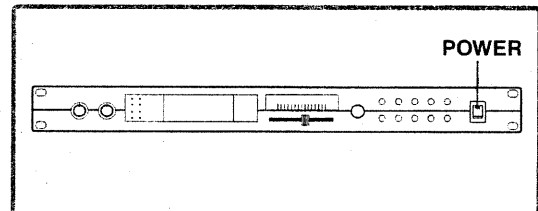

Power on your equipment as described in the following. After the devices are powered on, set the volumes to each connected device equipment.

- Turn the volume controls on your equipment all the way down before powering up.

Keyboards, etc. → Mixing Console → SRQ-4015 → Power Amplifier

A few seconds after power-up, the display changes as shown below. This is the default status called "Play Mode" (p. 23).

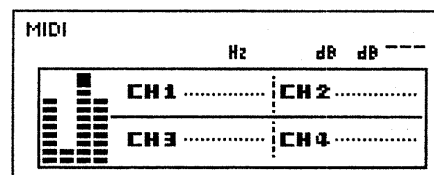

- This unit is equipped with a protection circuit. A brief interval (a few seconds) after power-up is required before the unit can operate normally.
- When powered off, the SRQ-4015 will send out any input signal directly through the output.
- Depending on the placement of the SRQ-4015, you may experience difficulty reading the display. In this case, you can adjust the contrast of the display (p. 19).

Turning Off the Power

Power down your equipment in the reverse order of the power-on procedure.

Points to check before powering down

Make sure that the volumes of all connected audio equipment is turned all the way down.

- If you leave the volume levels of your equipment turned up when you turn off the power, a loud noise may occur that can cause damage to your equipment.



When the "KEEP POWER ON" message (p. 40) appears in the display, do not turn off the power. If you do, the unit may return to the initial factory setting.

Basic Operations

To Set the Input and Output Level

Internal Signal Flow

The diagram below provides an overview of the audio signal flow. For further information, see the Block Diagram (p. 44).

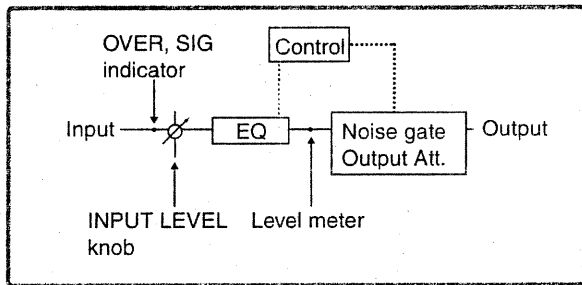

The level meter on this unit indicates the EQ output level, and is positioned in front of the level meter control. To adjust the overall output level, refer to "Setting the Output Level" (p. 14).

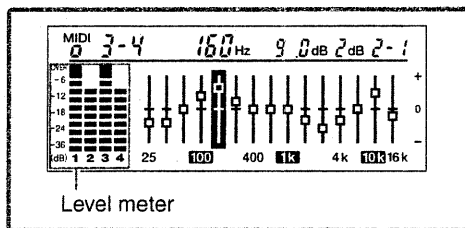

NOTE

When the level meter shows input overload during the EQ setting, audio signals are distorted. Be sure to set the input signals to an appropriate level.

Setting the Input Level

Set the preferred input level for input signals. The SRQ-4015 has a four-channel input, and you can adjust the input level for each channel individually.

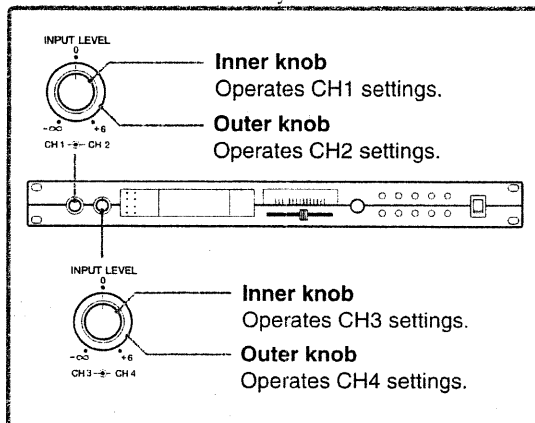

For Balanced Output

It is recommended that the [INPUT LEVEL] knob be normally positioned at "0." The "0" position is the Uni-Gain position, where the output level is the same as the level of input signals.

When the unit is accepting sound signals, "SIG" lights in green.

If OVER lights up, reduce the output level from the connected devices.

For Unbalanced Output

With the [INPUT LEVEL] knob positioned at "0" the volume goes down at BYPASS mode (p. 16). To set the level to Uni-Gain, adjust the level of the input signals by turning [INPUT LEVEL].

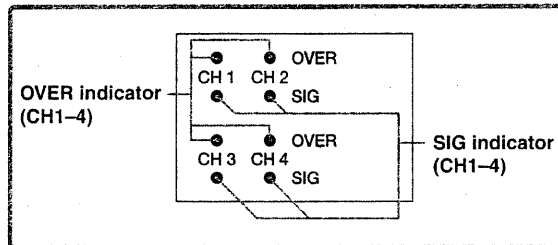

Setting the Output Level (OUTPUT)

Set the output level for each connected equipment. You can adjust the output level from each channel individually.

You can also readjust out-of-phase signals by inverting the phase on each channel.

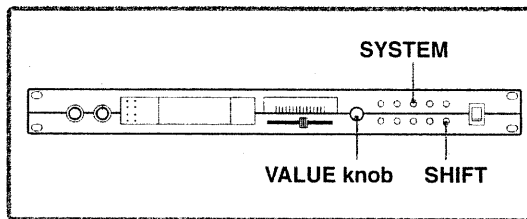

1. Together press both [SHIFT] and [SYSTEM].

[SYSTEM] lights in green, and the "SYSTEM SETTING" screen appears.

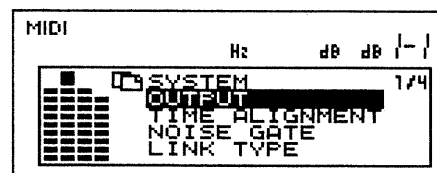

- Turn [VALUE] to select "OUTPUT," then press [VALUE].

The "OUTPUT" screen appears.

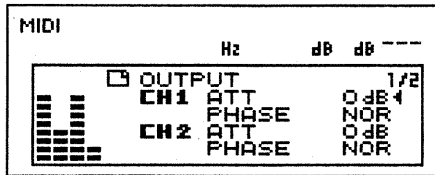

- Turn [VALUE] to select the value you wish to adjust, then press [VALUE].

• **CH 1 ATT**

Adjusts the output level from channel 1.
0dB - -60dB, -INF (-∞) dB

• **CH 1 PHASE**

Sets the phase for channel 1.
NOR : Normal phase
INV : Inverted phase

• **CH 2 ATT**

Adjusts the output level from channel 2.
0dB - -60dB, -INF (-∞) dB

• **CH 2 PHASE**

Sets the phase for channel 2.
NOR : Normal phase
INV : Inverted phase

• **CH 3 ATT**

Adjusts the output level from channel 3.
0dB - -60dB, -INF (-∞) dB

• **CH 3 PHASE**

Sets the phase for channel 3.
NOR : Normal phase
INV : Inverted phase

• **CH 4 ATT**

Adjusts the output level from channel 4.
0dB - -60dB, -INF (-∞) dB

• **CH 4 PHASE**

Sets the phase for channel 4.
NOR : Normal phase
INV : Inverted phase

- Turn [VALUE] to adjust the output level.

When you press [CH3] ([SYSTEM]), the settings are placed in effect, the "SYSTEM SETTING" screen reappears.

Together press both [SHIFT] and [SYSTEM] (or press [CH3] ([SYSTEM]) twice) to go to the Play Mode.



The output level is stored to the system memory when you store a setting (p. 31).

Changing the Input/Output Routing (INPUT SELECT)

You can output a monaural or two-channel input source separately from four channels by changing the internal signal flow.



Since the unit divides the signal before EQ, the EQ settings for CH1, CH2, CH3 and CH4 are reflected in each output signal.

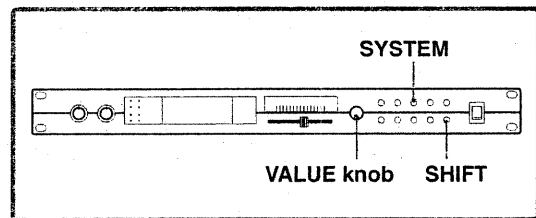

- Together press both [SHIFT] and [SYSTEM].
[SYSTEM] lights in green, and the "SYSTEM SETTING" screen appears.
- Turn [VALUE] to select "INPUT SELECT," then press [VALUE].

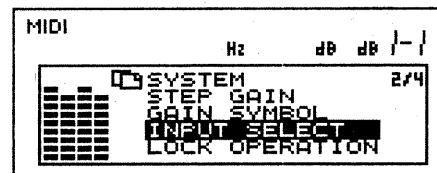

The "INPUT SELECT" screen appears.

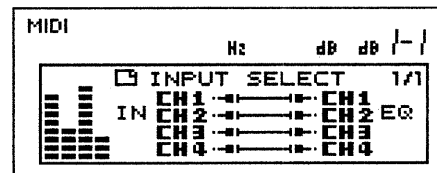

Basic Operations

3. Turn [VALUE] to define the INPUT and OUTPUT routes.

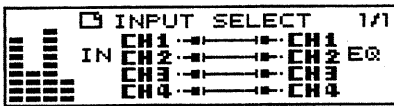

Set the routes for four-channel input and four-channel output.



The signal input to CH 1 is routed to CH1 and CH2, and the signal input to CH 3 is routed to CH3 and CH4, and all are output separately through each EQ block.

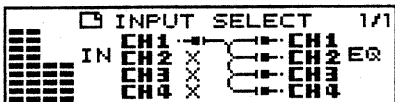

The signal input to CH 1 is routed to CH1, CH2, CH3 and CH4, and output through each EQ block separately.

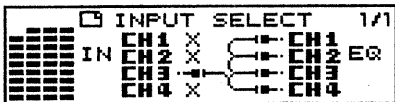

The signal input to CH 3 is routed to CH1, CH2, CH3 and CH4, and output through each EQ block separately.

When you press [CH3] ([SYSTEM]), the "NOW WORKING KEEP POWER ON" message appears in the display, and the settings are placed in effect. Then the "SYSTEM SETTING" screen reappears.

Together press both [SHIFT] and [SYSTEM] (or press [CH3] ([SYSTEM]) twice) to go to the Play Mode.



At BYPASS mode, the signal path remain as CH1-CH1, CH2-CH2, CH3-CH3, CH4-CH4, regardless to these settings

To Let the Signals Bypass the Effect (BYPASS)

You can disable the equalizing effect and send the input signal directly through the output, by using the BYPASS function.

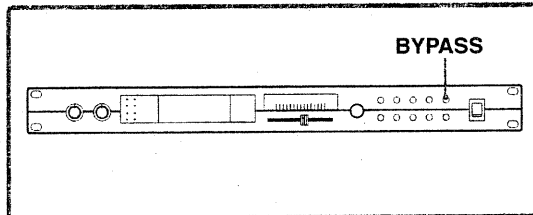

1. Press [BYPASS].

[BYPASS] lights in orange, and the BYPASS function is on.

To Turn Off the BYPASS Function

Press [BYPASS] once again to turn off the light of the button.



You can also turn on/off the BYPASS function using a foot switch (FS-5U; sold separately) (p. 33).



The BYPASS settings are stored to the system memory when you store a setting (p. 31).

To Disable the Controls (LOCK)

You can disable the functions of buttons and knobs on the panel and protect the settings by turning on the LOCK function. The LOCK function can be set to either "all controls" or "all controls except MEMORY LOAD."



You can use the LOCK function only in the Play Mode (p. 23).

Locking the Controls

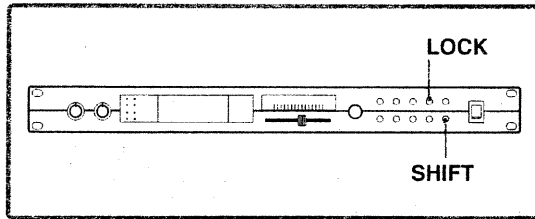

1. While pressing [SHIFT], press [LOCK].
"LOCK LEVEL 1" or "LOCK LEVEL 2" appears in the display, and the LOCK function is turned on.

Unlocking the Controls

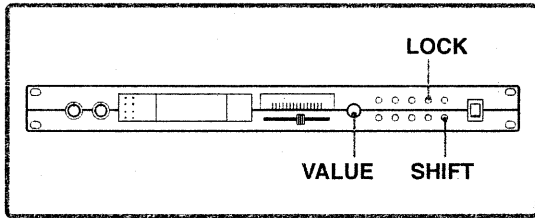

1. While pressing [SHIFT] and [VALUE], press [LOCK].

NOTE

The LOCK function setting remains effective even after you power-off the unit.

Setting the Lock Function Level

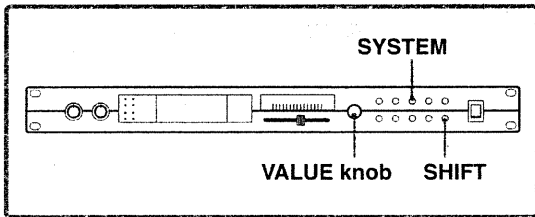

1. Together press both [SHIFT] and [SYSTEM].
[SYSTEM] lights in green, and the "SYSTEM SETTING" screen appears.
2. Turn [VALUE] to select "LOCK OPERATION," then press [VALUE].

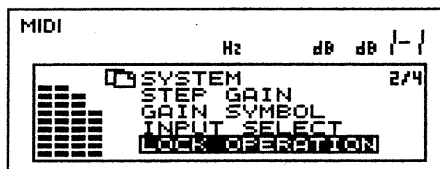

The "LOCK OPERATION" screen appears.

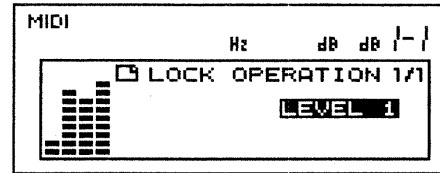

3. Turn [VALUE] to select "LEVEL 1" or "LEVEL 2," then press [VALUE].

• LEVEL 1

Locks all controls except those related to recalling the stored settings from memory. While in this state, you can call up the settings simply by pressing [MEMORY]. (Note that in this case, the procedure differs from that explained on (p. 32).).

• LEVEL 2

Locks all controls.

When you press [CH3] ([SYSTEM]), the "NOW WORKING KEEP POWER ON" message appears in the display, and the settings are placed in effect. Then the "SYSTEM SETTING" screen reappears.

Together press both [SHIFT] and [SYSTEM] (or press [CH3] ([SYSTEM]) twice) to go to the Play Mode.

HINT

The MIDI remote control function works during the LOCK function is ON.

To Edit System Parameters

This chapter explains the system setup of this unit.

Setting the Gain Level Controlling Range By Steps (STEP GAIN)

You can set the controlling range by steps when adjusting the overall value of the gain level. The "rough" step setting enables you to change the value faster, while the "smooth" step setting can be used for intensive adjustment of the equalizer.

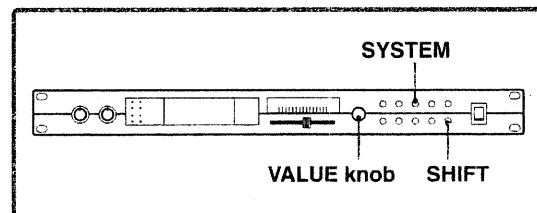

Basic Operations

1. Together press both [SHIFT] and [SYSTEM].
[SYSTEM] lights in green, and the "SYSTEM SETTING" screen appears.
2. Turn [VALUE] to select "STEP GAIN," then press [VALUE].

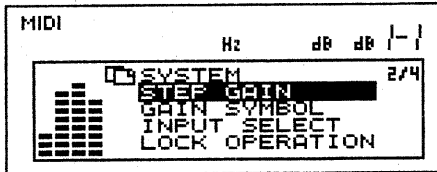

The "STEP GAIN" screen appears.

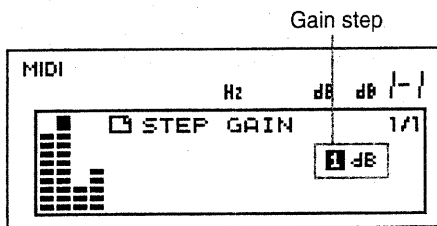

3. Turn [VALUE] to adjust the gain steps.
You can select the steps from 1 to 6 dB (You can adjust the gain level in increments of 0.1dB (p. 23)).

When you press [CH3] ([SYSTEM]), the settings are placed in effect, the "SYSTEM SETTING" screen reappears. Together press both [SHIFT] and [SYSTEM] (or press [CH3] ([SYSTEM]) twice) to go to the Play Mode.



The gain steps are stored in system memory when you save your settings (p. 31).

Readjusting the Frequency slider (CALIBRATION)

If the frequency shown in the display does not properly reflect the position of the Frequency slider, you can fine-adjust its position.



The fine tuning is carried out one calibration marking at a time. Once you have started the readjustment, be sure to complete the procedure. Otherwise, the setting will not take effect.

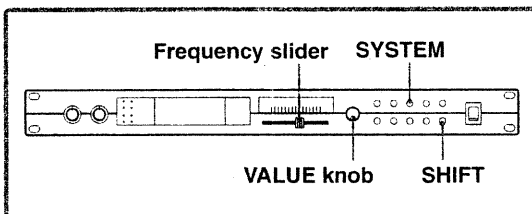

1. Together press both [SHIFT] and [SYSTEM].
[SYSTEM] lights in green, and the "SYSTEM SETTING" screen appears.
2. Turn [VALUE] to select "CALIBRATION," then press [VALUE].

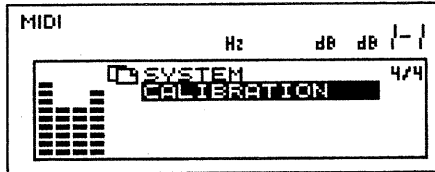

The "CALIBRATION" screen appears.

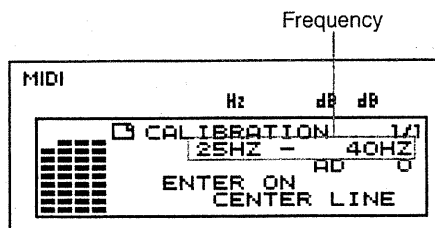

3. Move the Frequency slider so it points at the middle of the displayed frequency, then press [VALUE].
Move the Frequency slider according to the displayed frequency as shown below.

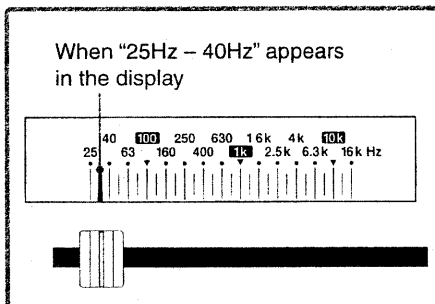

Press [VALUE]. The adjustment has been set, and the next frequency is shown in the display.

4. Repeat Step 3 to set the rest of the frequency.
Proceed while checking the frequency shown in the display.

After the fine-tuning procedure is completed, the "NOW WORKING KEEP POWER ON" message appears in the display, and the settings are placed in effect. Then the "SYSTEM SETTING" screen reappears. Together press both [SHIFT] and [SYSTEM] (or press [CH3] ([SYSTEM]) twice) to go to the Play Mode.

To Cancel the Readjusting

Together press both [SHIFT] and [SYSTEM] at any point during this operation. Any adjustments made up to this point are discarded, and the "SYSTEM SETTING" screen reappears. Together press both [SHIFT] and [SYSTEM] to go to the Play Mode.

Adjusting the Contrast of the Display (LCD CONTRAST)

You may wish to adjust the contrast of the display immediately after power-up, under unusual viewing conditions, or after the unit has been on for an extended period of time. Adjust the brightness of the screen as explained in the following.

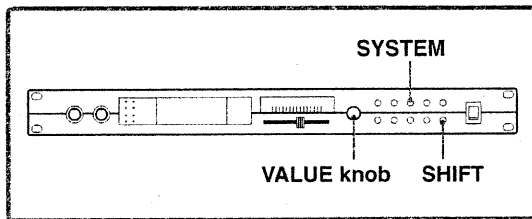

1. Together press both [SHIFT] and [SYSTEM].
[SYSTEM] lights in green, and the "SYSTEM SETTING" screen appears.
2. Turn [VALUE] to select "LCD CONTRAST," then press [VALUE].

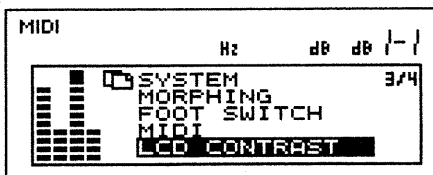

The "LCD CONTRAST" screen appears.

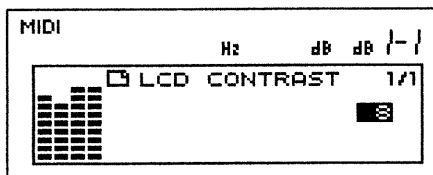

3. Turn [VALUE] to adjust the contrast of the display.

When you press [CH3] ([SYSTEM]), the "NOW WORKING KEEP POWER ON" message appears in the display, and the settings are placed in effect. Then the "SYSTEM SETTING" screen reappears.

Together press both [SHIFT] and [SYSTEM] (or press [CH3] ([SYSTEM]) twice) to go to the Play Mode.

Changing How Things Are Displayed (GAIN SYMBOL)

You can change the display patterns of the frequency lines and the gain levels on the equalizer editing display (3 types).

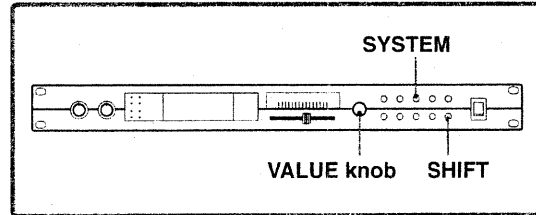

1. Together press both [SHIFT] and [SYSTEM].
[SYSTEM] lights in green, and the "SYSTEM SETTING" screen appears.
2. Turn [VALUE] to select "GAIN SYMBOL," then press [VALUE].
The "GAIN SYMBOL" screen appears.

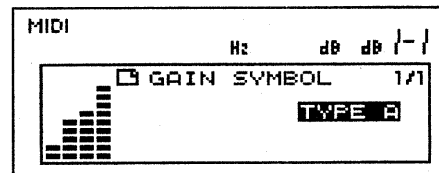

3. Turn [VALUE] to select the desired display pattern.

- TYPE A

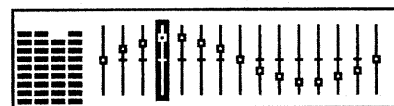

- TYPE B

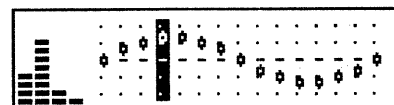

- TYPE C



When you press [CH3] ([SYSTEM]), the settings are placed in effect, the "SYSTEM SETTING" screen reappears. Together press both [SHIFT] and [SYSTEM] (or press [CH3] ([SYSTEM]) twice) to go to the Play Mode.



The display pattern is stored to the system memory when you store a setting (p. 31).

Basic Operations

The SRQ-4015 has the following System Parameters. You can edit the parameters on the "SYSTEM" editing screen. For further information about these parameters, read the reference pages for each parameter.

Adjusting the Output Level (OUTPUT)

You can adjust the signals' output level according to each connected device (p. 14).

Link Function (LINK)

By linking CH1 with CH2, or CH3 with CH4, you can edit settings for two channels at the same time (p. 21).

You can copy the entire settings of one channel to another (p. 22).

Noise Gate (NOISE GATE)

By deleting all sound below a certain level, you can reduce the remaining noise that can be heard at soundless periods (p. 29).

Time Alignment (TIME ALIGNEMENT)

If the speakers that are connected to the channels are placed at a wide distance, you can adjust the sound time lag for each channel using a delay effect (p. 30).

Lock Function (LOCK)

You can prevent the settings from being changed by unintentional action to controls on the panel (p. 16).

Morphing (MORPHING)

You can flatten the changing instant between 2 to 4 Memories. You can do this by MIDI control (p. 36), or you can set the Frequency slider to control the morphing during the Play Mode (p. 27).

Foot Switch (FOOT SWITCH)

You can remotely control some functions of this unit by connecting a foot switch (p. 33).

MIDI

You can set up the SRQ-4015 for MIDI connections (p. 34).

To Select Channels

When setting the equalizer, first select a channel and then operate on the editing screen.

You can select from channel 1 (CH1), channel 2 (CH2), channel 3 (CH3) and channel 4 (CH4). You can also link channel 1 with channel 2 or channel 3 with channel 4 and edit them together.

Setting Each Channel

Set the equalizer for each channel.

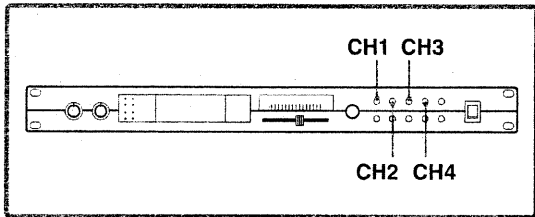

To set each channel separately, press [CH1], [CH2], [CH3] or [CH4] to select the channel you wish to control.

The selected button lights in green, and the equalizer editing screen appears.

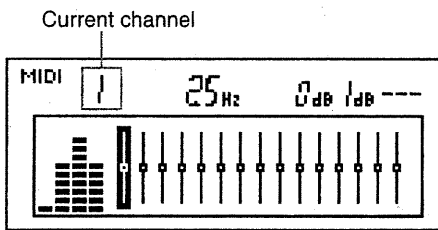

Adjusting the EQ Settings for CH1, 2 or CH3, 4 at the Same Time (LINK)

By linking CH1 with CH2 (CH3 with CH4), you can edit the settings on both channels at the same time. The LINK function also provides for customization, enabling you to do things such as clone the settings of one channel on another, or have the same amount of change be applied to the gain level of all settings.

You can also copy the entire settings of one channel to another to arrange for CH1 and CH2 (CH3 and CH4) to keep the same settings (p. 22).

Linking Both Channels

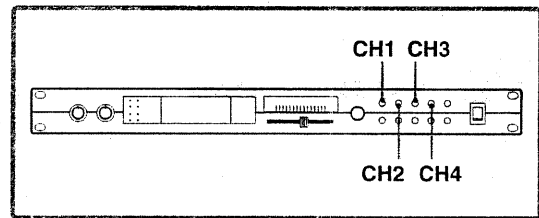

1. Press [CH1] and [CH2] ([CH3] and [CH4]) at the same time.

[CH1] and [CH2] ([CH3] and [CH4]) blink, and the "LINK" screen appears.

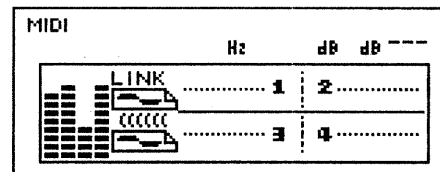

2. Press [CH1] or [CH2] ([CH3] or [CH4]).

[CH1] and [CH2] ([CH3] or [CH4]) light in green, and the equalizer editing screen of pressed channel appears.

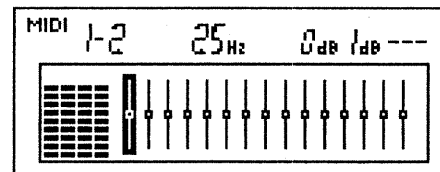

Settings made affect both CH1 and CH2 (CH3 and CH4).

To Select Channels

To Select Channels

Selecting the Link Type

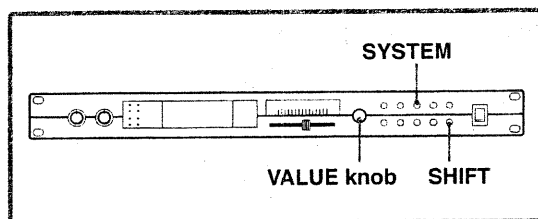

1. Together press both [SHIFT] and [SYSTEM].
[SYSTEM] lights in green, and the "SYSTEM SETTING" screen appears.
2. Turn [VALUE] to select "LINK TYPE," then press [VALUE].

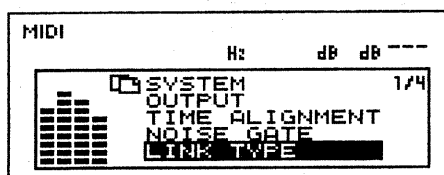

The "LINK TYPE" screen appears.

Link type

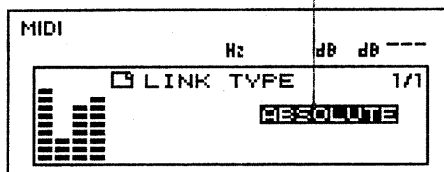

3. Turn [VALUE] to select the desired link type.

- **ABSOLUTE**

The gain level settings of both channels are set to match those shown in the editing screen.

- **RELATIVE**

When editing has been carried out with respect to the channel shown in the editing screen, the gain level of the other linked channel will be changed by an amount equivalent to the amount of change that actually resulted from the edit.

When you press [CH3] ([SYSTEM]), the settings are placed in effect, the "SYSTEM SETTING" screen reappears.

Together press both [SHIFT] and [SYSTEM] (or press [CH3] ([SYSTEM]) twice) to go to the Play Mode.



The link type is stored to the system memory when you store a setting (p. 31).

Copying the Settings of One Channel to the Other

You can copy the entire settings of one channel to another.

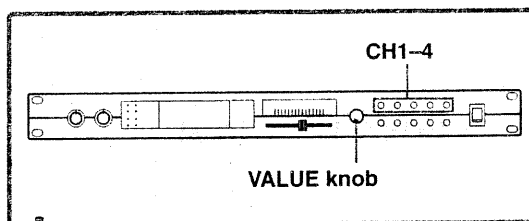

1. Press and hold down the copy-destination channel button ([CH1], [CH2], [CH3] or [CH4]) for more than 2 seconds.
The pressed button blinks, and the "COPY" screen appears.

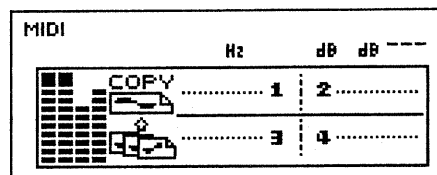

2. Press the copy-source channel button ([CH1], [CH2], [CH3] or [CH4]).

Copying begins, with the content referenced by the channel button just pressed being copied to the channel selected in step 1.

Example: To copy [CH1] settings to [CH2]

Press and hold down [CH2] for more than 2 seconds at Step 1, and press [CH1] after "COPY" appears in the screen.



You can undo the copying operation by holding down [SHIFT] while you press [UNDO/REDO]. To redo the canceled copy, together press [SHIFT] and [UNDO/REDO] again (p. 30).

Sound Creation

Adjusting the Tone (Editing the Graphic Equalizer)

You can adjust the equalizer using the [VALUE] knob and the Frequency slider while looking at the display.

You can also flatten the equalizer with a touch of a button (p. 24), create an easy tone curve (p. 26), or detect the point at which feedback occurs (p. 24).

Normal Use of the Equalizer

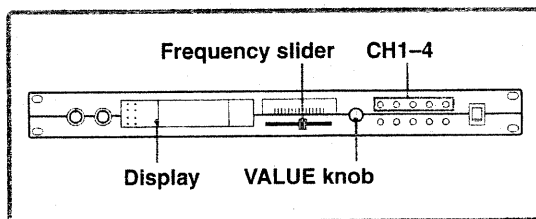

1. Press the [CH] button ([CH1], [CH2], [CH3] or [CH4]) to select the channel you wish to set up (p. 21).
The pressed [CH] button lights in green, and the equalizer editing screen appears.
2. Use the Frequency slider to select the frequency whose gain level you wish to adjust.

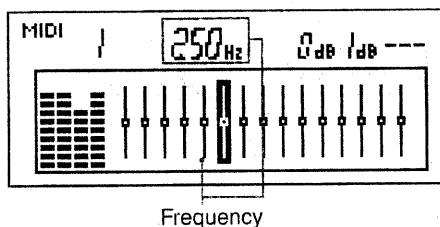

You can also select a frequency by turning in while pressing [VALUE]. Also, if you keep holding down [VALUE] after press-turning it, the frequency cursor continue to move in the direction you turned the knob.

3. Turn [VALUE] to adjust the gain level.

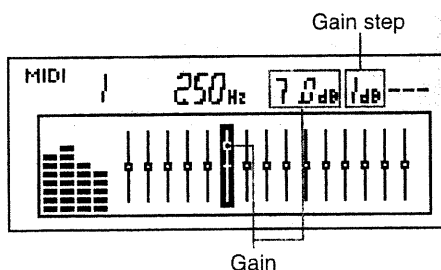

You can change the adjusting gain steps (p. 17).



You can adjust the gain level in increments of 0.1dB by turning [VALUE] while pressing [SHIFT].

4. Repeat Steps 2 to 3 to adjust other values.
5. Press the [CH] button that is lit in green.
The system returns to the Play Mode.

About the Play Mode

A few seconds after power-up, the display changes as shown below. This is the default position called "Play Mode."

In Play Mode, the current EQ settings curve and the output level are shown in the display.

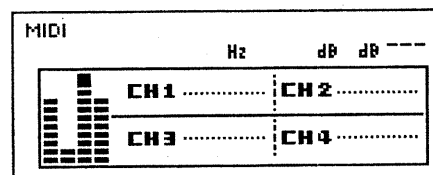

Functions Controllable in the Play Mode

- Memory Storage (p. 31)
- Memory Recall (p. 32)
- Morphing Control (p. 30)
- LOCK function (p. 16)
- LINK function (p. 21)
- Copy function (p. 22)
- UNDO/REDO (p. 30)

You can only perform these functions in the Play Mode.

How to Return to the Play Mode from Editing Modes

System Editing Screen

Press [SHIFT] + [SYSTEM] until the [CH3] ([SYSTEM]) indicator is extinguished.

Equalizer Editing Screen

Press the lit [CH] button.

SEARCH Screen

Press the lit [CH] button twice.

SWEEP Screen

Press the lit [CH] button twice.

WIDE Screen

Press the lit [CH] button twice.

Setting the Entire Gain Level Back to 0 dB (FLAT)

You can set the entire gain level back to 0 dB with a touch of a button. This is convenient when you wish to perform settings all over again.

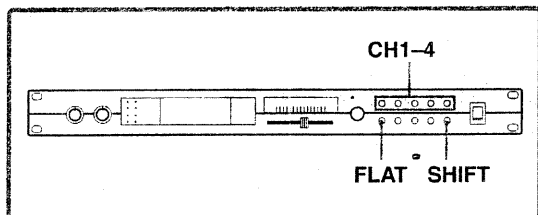

1. Press the [CH] button ([CH1], [CH2], [CH3] or [CH4]) to select the channel you wish to set back to 0 dB. (p. 21)
The selected [CH] button lights in green, and the equalizer editing screen appears.
2. Together press both [SHIFT] and [FLAT].
The entire gain level on the selected channel returns to 0 dB.



The FLAT function can also be used when performing SEARCH (p. 24), WIDE (p. 26), SWEEP (p. 26).



The FLAT function can also be used when the unit is in the Play Mode.

Detecting the Feedback Point (SEARCH)

You can easily detect the point at which feedback occurs by looking at the display.

Searching the Point of Feedback

This is convenient for detecting the frequency of the center of a snare drum, or for finding the cause of an unpleasant sound.

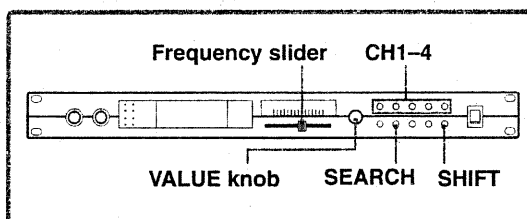

1. Press the [CH] button ([CH1], [CH2], [CH3] or [CH4]) to select the channel you wish to set up. (p. 21)
The selected [CH] button lights in green, and the equalizer editing screen appears.
2. Together press both [SHIFT] and [SEARCH].
The "SEARCH SETTING" screen appears.

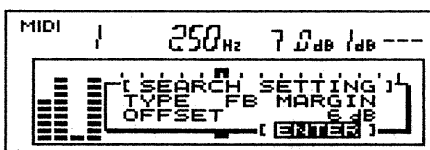

3. Turn [VALUE] to move the cursor to "TYPE," then press [VALUE].
4. Turn [VALUE] to select "MANUAL," then press [VALUE].
5. Turn [VALUE] to move the cursor to "OFFSET," then press [VALUE].
6. Turn [VALUE] to set the gain level, then press [VALUE].

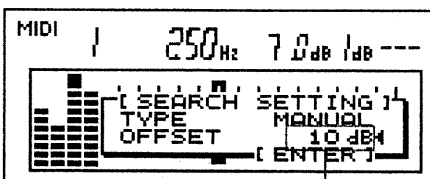

Offset level

- Turn [VALUE] to move the cursor to "ENTER," then press [VALUE].

The equalizer editing screen appears.

- Move the Frequency slider to find the point at which feedback occurs.

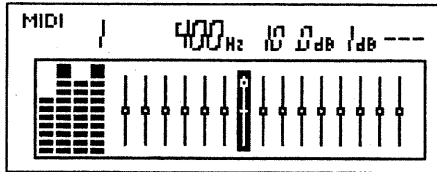

- At the point at which feedback occurs, turn [VALUE] to reduce the gain level.
- The reduced gain level will be reflected to the preset gain level.

To return to the Play Mode, press [SEARCH] twice (or either [CH] button once).

Taking the Margin of the Feedback Point

You can detect the point at which feedback occurs by first boosting the gain level to make it easier to cause a feedback, and then moving the boosted bandwidth around.

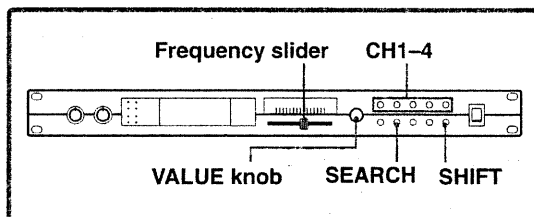

- Press the [CH] button ([CH1], [CH2], [CH3] or [CH4]) to select the channel you wish to set up. (p. 21)
- The selected [CH] button lights in green, and the equalizer editing screen appears.

- Together press both [SHIFT] and [SEARCH].
- The "SEARCH SETTING" screen appears.

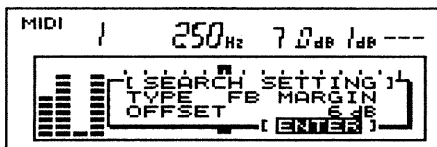

- Turn [VALUE] to move the cursor to "TYPE," then press [VALUE].
- Turn [VALUE] to select "FB MARGIN," then press [VALUE].

- Turn [VALUE] to move the cursor to "OFFSET," then press [VALUE].

- Turn [VALUE] to set the gain level, then press [VALUE].
- The gain level is boosted as has been set.

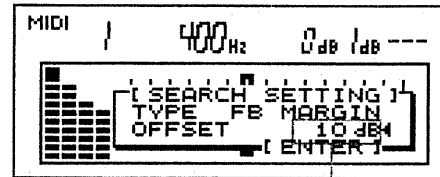

Offset level

- Turn [VALUE] to move the cursor to "ENTER," then press [VALUE].
- The equalizer editing screen appears.

The equalizer editing screen appears.

- Move the boosted band around with the Frequency slider to detect the point at which feedback occurs.

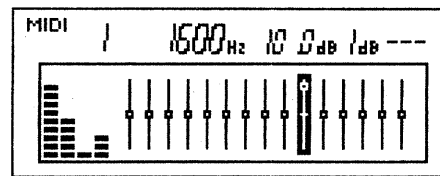

- At the point at which feedback occurs, turn [VALUE] to reduce the gain level.

The reduced gain level will be reflected to the preset gain level. If you reduce the gain level enough to prevent the feedback, the margin created will be counted as an offset level to the original gain.

To return to the editing screen, press [SEARCH] twice (or either [CH] button once).

Drawing an Easy EQ Curve Line (SWEEP)

You can easily draw a rough EQ curve line by using the Frequency slider and the [VALUE] knob.

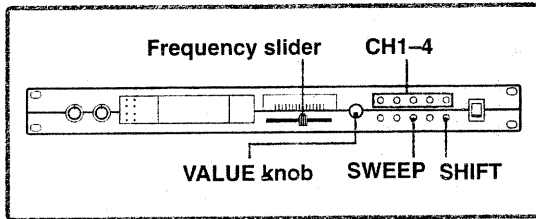

1. Press the [CH] button ([CH1], [CH2], [CH3] or [CH4]) to select the channel you wish to set up. (p. 21)
The selected [CH] button lights in green, and the equalizer editing screen appears.
2. Together press both [SHIFT] and [SWEEP].
[SWEEP] lights up.
3. While looking at the display, use the Frequency slider to move through the frequencies you wish to draw an EQ curve line, and turn while pressing [VALUE] to adjust the gain level.

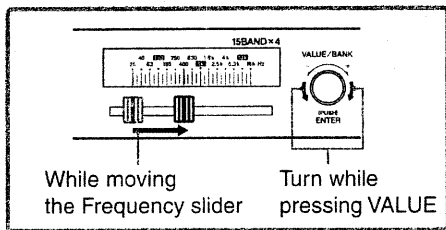
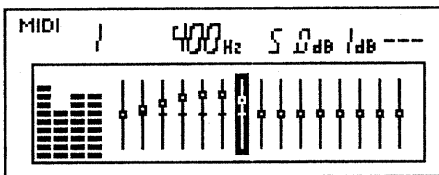

To return to the editing screen, press [SWEEP] (or either [CH] button).

Simultaneously Adjusting A Wide Range Of Adjacent Bands (WIDE)

You can set the gain level of a wide range of adjacent frequencies on both sides of a selected band.

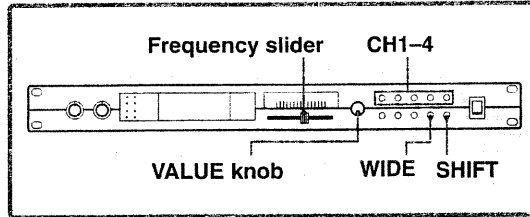

1. Press the [CH] button ([CH1], [CH2], [CH3] or [CH4]) to select the channel you wish to set up. (p. 21)
The pressed [CH] button lights in green, and the equalizer editing screen appears.
2. Together press both [SHIFT] and [WIDE].
The "WIDE SETTING" screen appears.

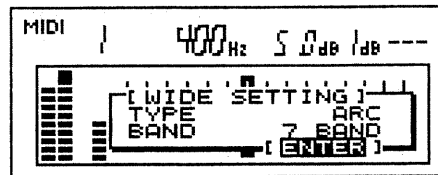

3. Turn [VALUE] to move the cursor to "TYPE," then press [VALUE].
4. Turn [VALUE] to select "FIX" or "ARC," then press [VALUE].

• **When "ARC" is selected**

You can angle the pattern of the EQ gain level within the selected group of frequencies.

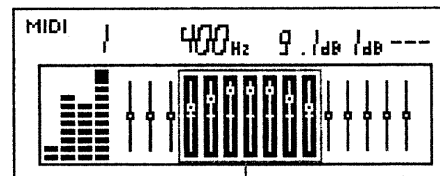

Selected frequencies

• **When "FIX" is selected**

You can boost or reduce the entire gain level of the selected group of frequencies.

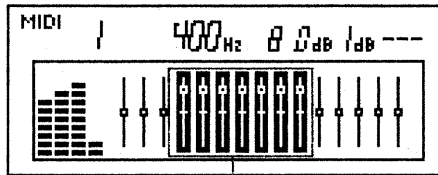

Selected frequencies

5. Turn [VALUE] to move the cursor to "BAND," then press [VALUE].
6. Turn [VALUE] to select the number of frequencies you wish to change as a group, then press [VALUE].

You can select from the following:

3 BAND, 7 BAND, 11BAND, 15BAND

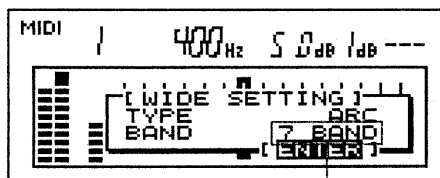

Number of selected frequencies

7. Turn [VALUE] to move the cursor to "ENTER," then press [VALUE].
The equalizer editing screen appears.
8. Move the Frequency slider to the frequency you wish to edit, and turn [VALUE] to adjust the gain level.

To return to the editing screen, press [WIDE] twice (or either [CH] button once).



At Step 8, you can change the number of frequencies you wish to change as a group by turning [VALUE] while you press and hold down it.



While on the WIDE mode, you can cut the gain level of the entire group of the selected frequencies by using the TOTAL CUT function (p. 28).

Smoothing the Transition Between Memories (MORPHING)

You can smooth the transition between 2 to 4 memories. You can do this by MIDI control (p. 36), or you can set the Frequency slider to do the controlling during the Play Mode.



To be able to use this function, you must first store the desired settings as memories. (p. 31)

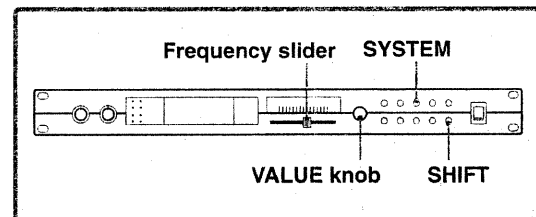

1. Together press both [SHIFT] and [SYSTEM].
[SYSTEM] lights in green, and the "SYSTEM SETTING" screen appears.
2. Turn [VALUE] to select "MORPHING," then press [VALUE].
The "MORPHING" screen appears.

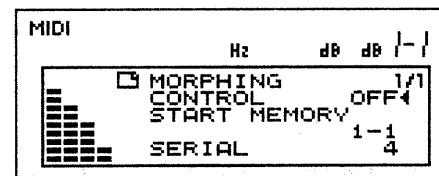

3. Turn [VALUE] to select "CONTROL," then press [VALUE].
4. Turn [VALUE] to select "ON," then press [VALUE].
To turn MORPHING off, select "OFF."
5. Turn [VALUE] to select "START MEMORY," then press [VALUE].

Sound Creation

6. Turn [VALUE] to select the lowest number of memories you want to morph, then press [VALUE].

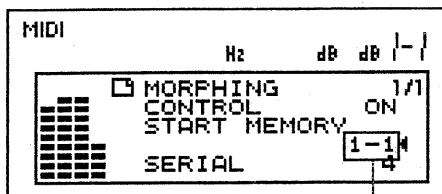

Memory number

7. Turn [VALUE] to select "SERIAL," then press [VALUE].
8. Turn [VALUE] to select the number of memories (up to 4) to morph, then press [VALUE].

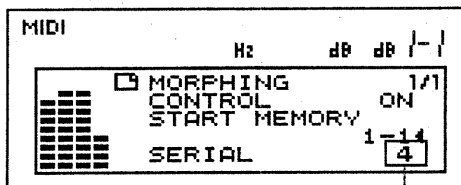

Memory number for the Morphing function

9. Press [CH3] ([SYSTEM]) three times to return to the Play Mode.
10. Use the Frequency slider to control morphing.
- The morphing memories are assigned to the Frequency slider. These memories are morphed by moving the Frequency slider.

Example: Morphing the memories 1-1, 1-2, 1-3

Select "1-1" at the "START MEMORY" field in Step 6, and select "3" at the "SERIAL" field in Step 8, and as above.

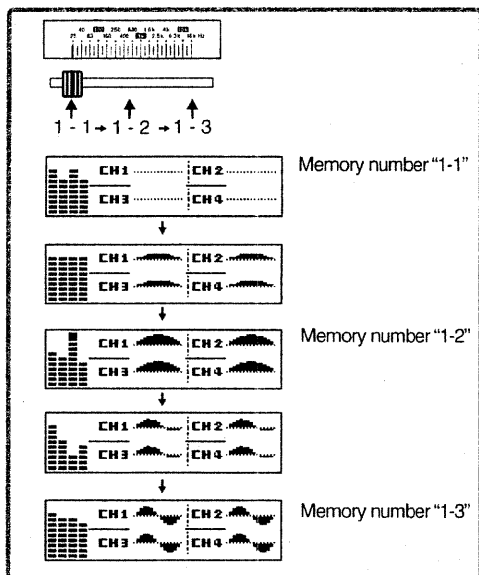

To Cut the Gain of Selected Frequencies to -60dB (TOTAL CUT)

You can cut the gain level of a selected frequency to -60dB with a touch of a button. This is convenient for erasing an always heard noise at a certain frequency.

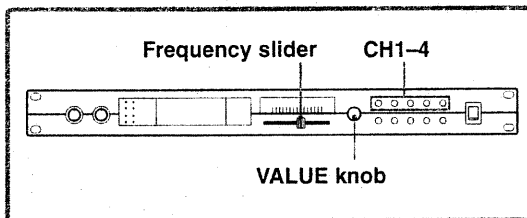

- Press the [CH] button ([CH1], [CH2], [CH3] or [CH4]) to select the channel you wish to set up. (p. 21)
- The selected [CH] button lights in green, and the equalizer editing screen appears.

- Use the Frequency slider to select the bandwidth you wish to cut.

- Press [VALUE].

The gain value of the selected bandwidth is cut.

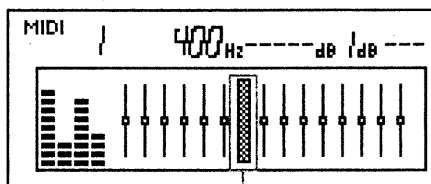

Frequency to be cut

If you press [VALUE] again, the system returns to its previous state.



If you use this function while on WIDE mode (p. 26), you can cut the gain level of the entire group of the selected frequencies.

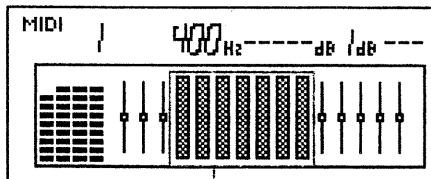

Frequencies to be cut

Reducing the Remaining Noise (NOISE GATE)

By deleting all sound below a certain level, you can reduce the remaining noise that can be heard at soundless periods.

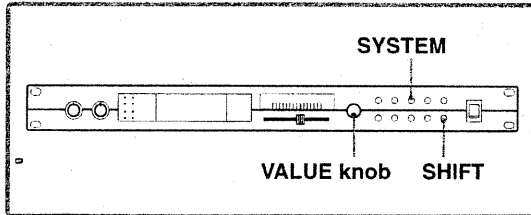

1. Together press both [SHIFT] and [SYSTEM].
[SYSTEM] lights in green, and the "SYSTEM SETTING" screen appears.
2. Turn [VALUE] to select "NOISE GATE," then press [VALUE].
The "NOISE GATE" screen appears.

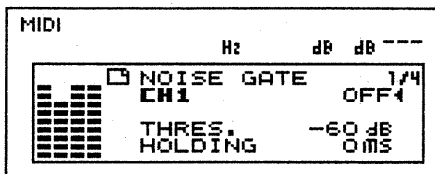

3. Turn [VALUE] to select the parameter you wish to edit.
The "NOISE GATE" Screen
Sets the Noise Gate for "CH1".

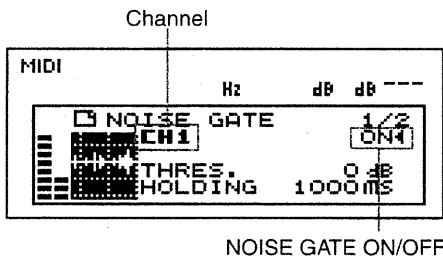

• "THRES." (THRESHOLD)

Sets the point from which the level is to be reduced.

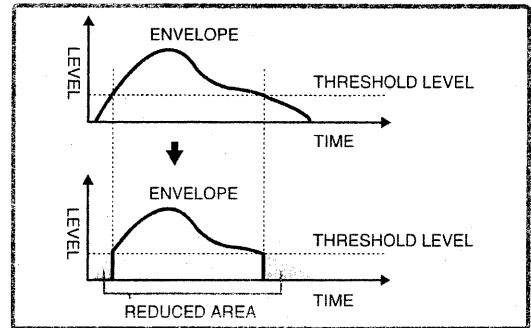

• "HOLDING" (HOLDING TIME)

Sets the time before release, when the signal goes down at the level below the threshold.

You can suppress the frequent intervals between the Gate on/off's that occur when the signals act with instability over and under the threshold level.

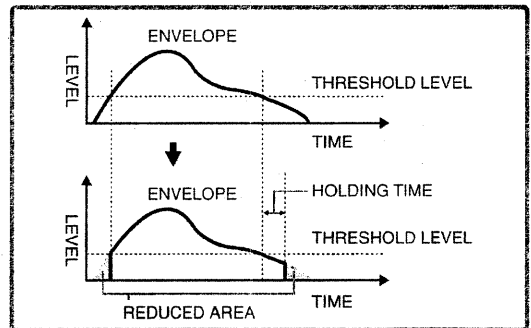

4. Turn [VALUE] to adjust the selected parameter.

When you press [CH3] ([SYSTEM]), the settings are placed in effect, the "SYSTEM SETTING" screen reappears. Together press both [SHIFT] and [SYSTEM] (or press [CH3] ([SYSTEM]) twice) to go to the Play Mode.



The NOISE GATE setting is stored in system memory when you save your settings (p. 31).

To Refine the Time Lag Between Channel Outputs (TIME ALIGNMENT)

If the speakers that are connected to the channels are placed at a wide distance, you can adjust the sound time lag for each channel using a delay effect.

This unit calculates the time and distance for TIME ALIGNMENT, and shows the rate at 340m per sound velocity.

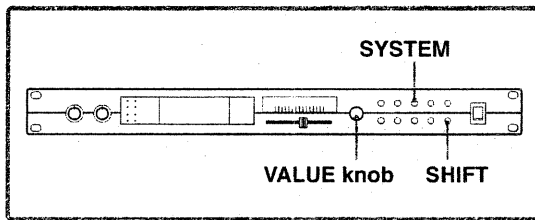

1. Together press both [SHIFT] and [SYSTEM].
[SYSTEM] lights in green, and the "SYSTEM SETTING" screen appears.
2. Turn [VALUE] to select "TIME ALIGNMENT," then press [VALUE].
The "TIME ALIGNMENT" screen appears.

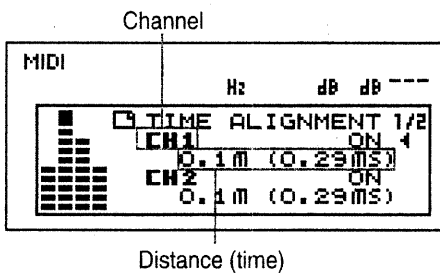

3. Turn [VALUE] to select the channel you wish to edit, then press [VALUE].
4. Turn [VALUE] to select "ON," then press [VALUE].
To turn TIME ALIGNMENT off, select "OFF."
5. Turn [VALUE] to move the cursor to the Distance (Time) field, then press [VALUE].
6. While looking at the display, turn [VALUE] to adjust the values (Distance or Time).

When you press [CH3] ([SYSTEM]), the settings are placed in effect, the "SYSTEM SETTING" screen reappears.

Together press both [SHIFT] and [SYSTEM] (or press [CH3] ([SYSTEM]) twice) to go to the Play Mode.



The TIME ALIGNMENT is stored in system memory when you save your settings (p. 31).

To Recover the Settings (UNDO/REDO)

Directly after a change has been made to the settings, you can recover the previous state, or recall the changed settings again.

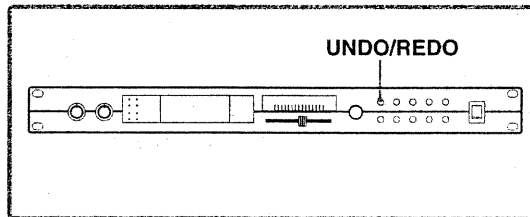

To recover the previous settings, press both [SHIFT] and [UNDO/REDO] directly after you have changed the settings. By pressing these buttons again, you can recall the changed settings again.

The UNDO/REDO function works for the following:

- **CHANNEL COPY (p. 22)**
The system returns to its state before the CHANNEL COPY operation.
- **MEMORY LOAD (p. 32)**
The system returns to its state before the MEMORY LOAD operation.
- **PLAY MODE (p. 23)**

If you press both [SHIFT] and [UNDO/REDO] at the Play Mode directly after you have changed the EQ gain settings, the system returns to the Play Mode state before any changes of the gain have been made.

To Store/Recall the Present Settings (MEMORY SAVE/LOAD)

You can store up to 16 patterns of EQ settings as memories (MEMORY SAVE). You can always recall these memories for instant use (MEMORY LOAD).

To Store the Current Settings (MEMORY SAVE)

The following settings can be stored in each memory.

- EQ Curve
- BYPASS ON/OFF (p. 16)
- OUTPUT (p. 14)
- TIME ALIGNMENT (p. 30)
- NOISE GATE (p. 29)
- LINK TYPE (p. 22)
- STEP GAIN (p. 17)
- GAIN SYMBOL (p. 19)

The EQ settings can be stored to the following Memory numbers.

- 1-1, 1-2, 1-3, 1-4, 2-1, 2-2, 2-3, 2-4**
3-1, 3-2, 3-3, 3-4, 4-1, 4-2, 4-3, 4-4

The number on the left denotes the Bank, while the number on the right denotes the Bank sub-number.

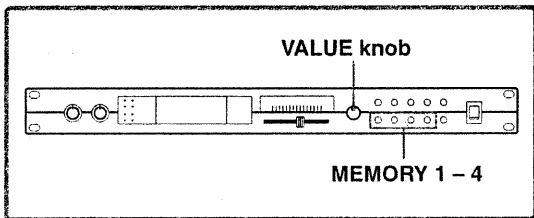

1. After you have finished the EQ settings, go back to the Play Mode.
2. Turn [VALUE] to select the Bank number of the Memory Number you wish to store the current settings.

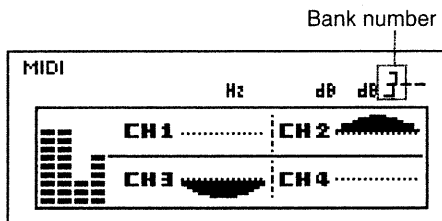

3. Press and hold down [MEMORY 1]-[MEMORY 4] for over 2 seconds.

The selected [MEMORY] button will enter the Bank sub-number.

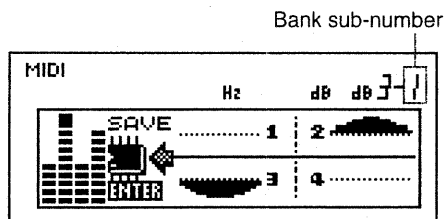

The pressed [MEMORY] button blinks, and "SAVE" appears in the display.

4. Press [VALUE].

The "NOW WORKING KEEP POWER ON" (p. 40) message appears in the display, and the current settings are stored to the selected Memory number.

Example: To store the current settings to "3-1"

Turn [VALUE] to select "3," then press [MEMORY 1] for over 2 seconds. "SAVE" appears in the display.

Press [VALUE].

To Store/Recall the Present Settings (MEMORY SAVE/LOAD)

To Recall the Stored Settings (MEMORY LOAD)

By calling up stored settings, the settings for the following can be called up.

- EQ Curve
- BYPASS ON/OFF (p. 16)
- OUTPUT (p. 14)
- TIME ALIGNMENT (p. 30)
- NOISE GATE (p. 29)
- LINK TYPE (p. 22)
- STEP GAIN (p. 17)
- GAIN SYMBOL (p. 19)

The EQ settings can be recalled from the following Memory numbers.

1-1, 1-2, 1-3, 1-4, 2-1, 2-2, 2-3, 2-4
3-1, 3-2, 3-3, 3-4, 4-1, 4-2, 4-3, 4-4

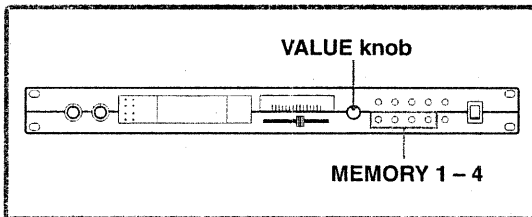

1. After you have finished the EQ settings, go back to the Play Mode.
2. Turn [VALUE] to select the Bank number of the Memory number you wish to recall.

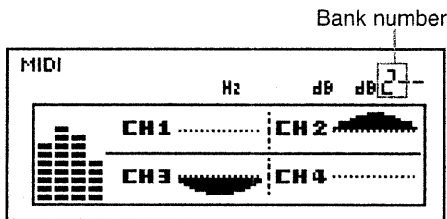

3. Press [MEMORY 1]-[MEMORY 4] to select the Bank sub-number of the Memory number.

The pressed [MEMORY] button will enter the Bank sub-number of the Memory number.

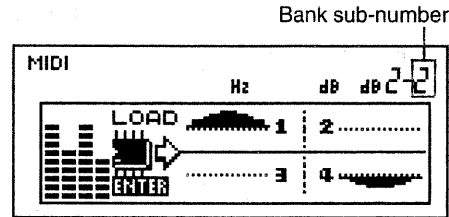

The pressed [MEMORY] lights up, and "LOAD" appears in the display.

4. Press [VALUE].

The selected memory is recalled.

Example: To recall the settings that are stored to "2-2"

Turn [VALUE] to select "2," then press [MEMORY 2] for over 2 seconds. "LOAD" appears in the display.

Press [VALUE].



If you press both [SHIFT] and [UNDO/REDO] together right after this operation, the recalled memory will be dismissed. If you press both [SHIFT] and [UNDO/REDO] together right after this again, the previously recalled memory will recover. (p. 30)

Remote Control

Using A Foot Switch

By connecting a foot switch to the FOOT SW port, you can lead signals through a bypass, or recall a memorized setting.

To Let the Signals Bypass the Effect (BYPASS)

You can control the BYPASS function (p. 16) using a foot switch.

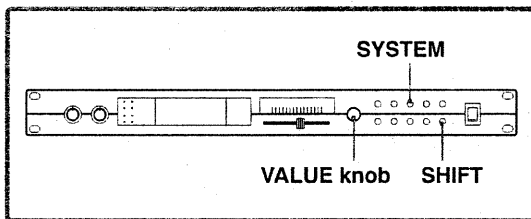

1. Together press both [SHIFT] and [SYSTEM].
[SYSTEM] lights in green, and the "SYSTEM SETTING" screen appears.
2. Turn [VALUE] to select "FOOT SWITCH," then press [VALUE].
The "FOOT SWITCH" display appears.

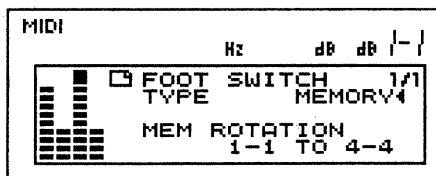

3. Turn [VALUE] to move the cursor to the upper field, then press [VALUE].
4. Turn [VALUE] to select "BYBASS" at the "TYPE" field.

When you press [CH3] ([SYSTEM]), the settings are placed in effect, the "SYSTEM SETTING" screen reappears. Together press both [SHIFT] and [SYSTEM] (or press [CH3] ([SYSTEM]) twice) to go to the Play Mode.

Recalling Memorized Settings in Turns (MEMORY ROTATION)

By pressing the foot switch, you can recall memories in turns over and over again. On this unit, you can set the desired range of memory numbers you wish to recall. This function works only in Play Mode.

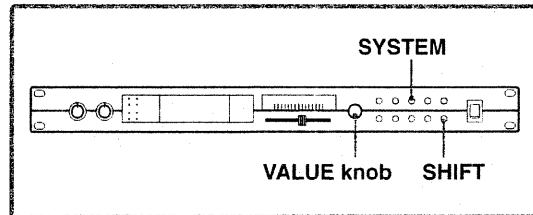

1. Carry out the same Steps 1-3 as in the previous "BYPASS" section.
2. Turn [VALUE] to select "MEMORY" at the "TYPE" field, then press [VALUE].
3. Set the desired range of memory numbers.
The SRQ-4015 can store up to 16 EQ settings to memory numbers "1-1" to "4-4" (p. 31). You can set the foot switch to select from these within the desired memory number range.

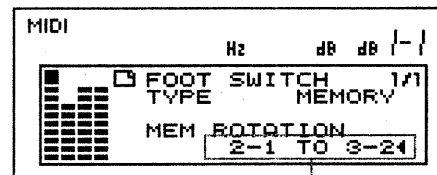

Range of selected memories

- 1 Turn [VALUE] to move the cursor to the memory number on the left side of the "MEM ROTATION" field.
- 2 Turn [VALUE] to select the smallest memory number you wish to recall, then press [VALUE].
- 3 Turn [VALUE] to move the cursor to the memory number on the right side of the "MEM ROTATION" field.
- 4 Turn [VALUE] to select the largest memory number you wish to recall, then press [VALUE].

Example: When you select "1-2" at Step 2, and "2-3" at Step 4.

Each time you press the foot switch, the selection occurs as follows.

"1-2" → "1-3" → "1-4" → "2-1" → "2-2" → "2-3"

When you press [CH3] ([SYSTEM]), the settings are placed in effect, the "SYSTEM SETTING" screen reappears. Together press both [SHIFT] and [SYSTEM] (or press [CH3] ([SYSTEM]) twice) to go to the Play Mode.

Use With MIDI Devices

About MIDI

This chapter explains MIDI fundamentals, and how the SRQ-4015 interacts with MIDI messages.

What Is MIDI?

MIDI stands for "Musical Instrument Digital Interface." This is a standard used throughout the world for the purpose of exchanging music data between electronic instruments and computers.

MIDI-compatible devices can exchange performance information with each other, regardless of manufacturer or model.

MIDI Connectors

MIDI messages (MIDI data or information) are exchanged using the following three types of connectors.

MIDI IN

For receiving MIDI messages from another device.

MIDI OUT

For sending MIDI messages from the master device.

MIDI THRU

For sending out unchanged MIDI messages received from another device.



On this unit, you can change functions of MIDI THRU/OUT connector as below at the "SYSTEM"- "MIDI" setting screen.

SOFT THRU

- ON : Both OUT and THRU functions are available.
- OFF : Only OUT function is available.

MIDI Channels

MIDI sends its information over several channels. To get messages to function as intended, you need to set the channel of the receiver so it matches that of the sender.

MIDI Messages Used by the SRQ-4015

MIDI uses a variety of MIDI messages to convey the various kinds of expression possible in a performance. MIDI messages can be broadly divided into two kinds: messages handled on a per-channel basis (Channel Messages), and messages that are handled irrespective of particular MIDI channels (System Messages).

Channel Messages

These are messages for transmitting performance operations.

Control change messages

Each function is distinguished by Controller Numbers, and can select parameters that have been set before operation. The selected parameters can be adjusted by changing the controlling values.

Program change messages

These are used for selecting a memory.

System Messages

These are messages (SysEx messages) that hold settings of devices.

By using these messages, you can send parameter settings to a sequencer for storage, or re-create identical settings on another SRQ-4015.



To exchange SysEx Messages, you must first set the same ID number to both devices. (p. 38)

MIDI Implementation Chart

The MIDI Implementation Chart is where you can check the types of MIDI messages the device can send and receive.

When using MIDI devices, compare the charts for each device, and confirm the compatible MIDI messages.

The MIDI Implementation Chart for the SRQ-4015 can be found at page 43.



A separate publication titled "MIDI Implementation" is also available. It provides complete details concerning the way MIDI has been implemented on this unit. If you should require this publication (such as when you intend to carry out byte-level programming), please contact the nearest Roland Service Center or authorized Roland distributor.

Changing settings from External MIDI Devices

By sending Control Change or Program Change messages from an external device, you can change settings of the SRQ-4015.

Setting the Reception Channel for MIDI Messages

Set the SRQ-4015 so that you can receive MIDI messages sent from an external device.

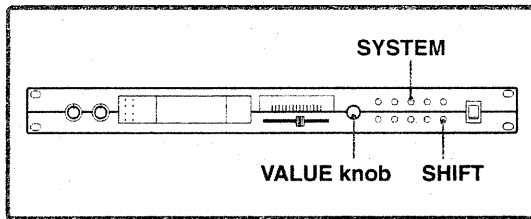

1. Together press both [SHIFT] and [SYSTEM].
[SYSTEM] lights in green, and the "SYSTEM SETTING" screen appears.
2. Turn [VALUE] to select "MIDI," then press [VALUE].
The "MIDI" screen appears.

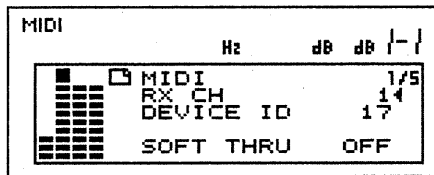

3. Turn [VALUE] to select "RX CH," then press [VALUE].
4. Turn [VALUE] to select the receiving channel.
 - **1-16**
To receive MIDI messages from the selected channel.
 - **OMNI**
To receive all MIDI messages.
 - **OFF MIDI**
Messages cannot be received.

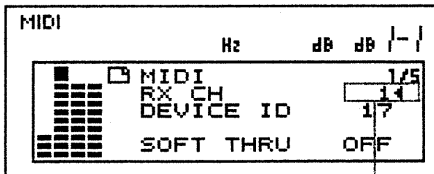

When you press [CH3] ([SYSTEM]), the "NOW WORKING KEEP POWER ON" message appears in the display, and the settings are placed in effect. Then the "SYSTEM SETTING" screen reappears.

Together press both [SHIFT] and [SYSTEM] (or press [CH3] ([SYSTEM]) twice) to go to the Play Mode.

Remote Control of the SRQ-4015 from an External MIDI Device (Control Change)

To operate this system from an external device, you must first set the receiving channel for MIDI messages as described on the left.

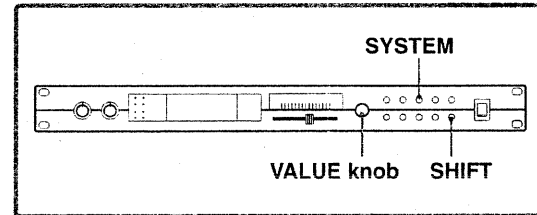

1. Together press both [SHIFT] and [SYSTEM].
[SYSTEM] lights in green, and the "SYSTEM SETTING" screen appears.
2. Turn [VALUE] to select "MIDI," then press [VALUE].
The "MIDI" screen appears.

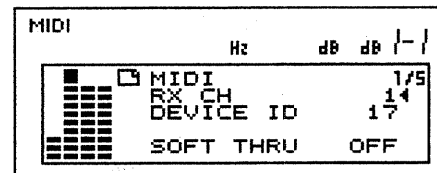

3. Turn [VALUE] to select the desired parameter, then press [VALUE].

The LEVEL editing screen

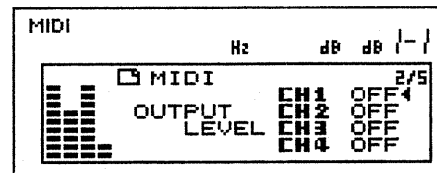

• LEVEL

Sets the volume.

OFF : Not Accepted

CC01 - CC31, CC64 - CC95

: Control Number 1 - 31, 64 - 95

Control Value	Setting Values
0	- ∞
1 - 61	-60dB - 0dB

Remote Control

The BYPASS/MORPHING editing screen

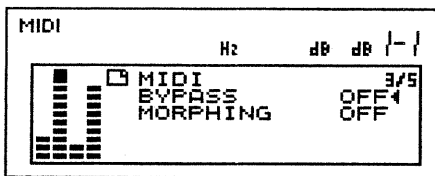

• BYPASS

Sets the Controller Number to switch on/off the BYPASS function.

OFF : Not Accepted

CC01 - CC31, CC64 - CC95

: Control Number 1 - 31, 64 - 95

Control Value	Setting Values
0 - 63	OFF
64 - 127	ON

• MORPHING

Sets the Controller Number to control Morphing.

OFF : Not Accepted

CC01 - CC31, CC64 - CC95

: Control Number 1 - 31, 64 - 95

Control Value	Setting Values
0-127	Correspond to the L/R (25Hz - 16 kHz) of faders

The CH SELECT/FRQ SELECT/GAIN SET Editing Screen

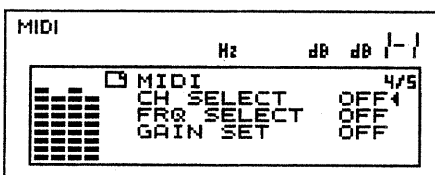

• CH SELECT

Sets the Controller Number for selecting the channel (CH1, CH2, CH3 or CH4) whose gain level you wish to adjust.

OFF : Not Accepted

CC01 - CC31, CC64 - CC95

: Control Number 1 - 31, 64 - 95

Control Value	Setting Values
0	CH1
1	CH2
2	CH3
3	CH4

• FRQ SELECT

Sets the Controller Number for selecting the frequency whose gain level you wish to control.

OFF : Not Accepted

CC01 - CC31, CC64 - CC95

: Control Number 1 - 31, 64 - 95

Control Value	Setting Values
0 - 14	Corresponds to every frequency from 25 through 16,000 Hz (15 bands)

• GAIN SET

Sets the Controller Number for setting the gain level.

OFF : Not Accepted

CC01 - CC31 : MSB

CC33 - CC63 : LSB

On this unit you can set the gain level in increments of 0.1 dB within 24 dB (240 steps). To manipulate these 240 GAIN STEPS, you use two Controller Numbers, in pairs consisting of the MSB (CC1-CC31), and the LSB (CC33-C63).

CONTROLLER NUMBERS CORRESPONDENCE

MSB	LSB
CC1	CC33
CC2	CC34
CC31	CC63

The GAIN SET screen on this unit works as the MSB Controller Number selection screen. When you select the MSB, the LSB Controller Number will be set automatically. When you adjust the gain level, send the control value to both MSB and LSB channels. The relations between the gain level and the MSB/LSB values are as listed below.

VALUE (MSB-LSB) - GAIN RELATIONS

MSB (CC1 - 31)	LSB (CC33 - 63)	GAIN
1	0 - 112	+0.8dB - +12dB
0	0 - 127	-12dB - +0.7dB
1	127	TOTAL CUT ON
1	126	TOTAL CUT OFF

VALUE (MSB-LSB) – GAIN RELATIONS

MSB (CC1 - 31)	LSB (CC33 - 63)	GAIN
1	112	+12dB
1	102	+11dB
1	92	+10dB
1	82	+9dB
1	72	+8dB
1	62	+7dB
1	52	+6dB
1	42	+5dB
1	32	+4dB
1	22	+3dB
1	12	+2dB
1	2	+1dB
0	119	+0dB
0	109	-1dB
0	99	-2dB
0	89	-3dB
0	79	-4dB
0	69	-5dB
0	59	-6dB
0	49	-7dB
0	39	-8dB
0	29	-9dB
0	19	-10dB
0	9	-11dB
0	0	-12dB

4. Turn [VALUE] to select the desired Controller Number, then press [VALUE].

When you press [CH3] ([SYSTEM]), the "NOW WORKING KEEP POWER ON" message appears in the display, and the settings are placed in effect. Then the "SYSTEM SETTING" screen reappears.

Together press both [SHIFT] and [SYSTEM] (or press [CH3] ([SYSTEM]) twice) to go to the Play Mode.

Selecting a memory from an External MIDI Device (Program Change)

To select a memory from an external MIDI device, you must first set the receiving channel for MIDI messages (p. 35).

The program change message corresponds to the memory number as below.

MSB	LSB
0	1-1
1	1-2
1	1
16	4-4

Sending and Receiving Settings Via MIDI (BULK DUMP/LOAD)

With the SRQ-4015, you can use SysEx Messages to re-create identical settings on another SRQ-4015, or send the EQ settings to a sequencer for storage. be under same settings, or record the EQ settings to a sequencer or other devices. This transmission of SysEx messages is called "Bulk Dump," and reception is called "Bulk Load."

Data Transfer (BULK DUMP)

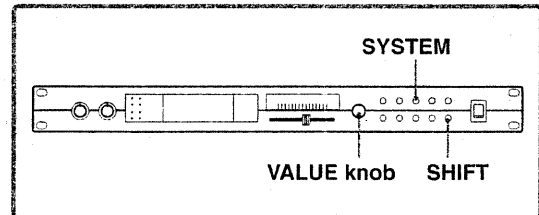

Saving Data on a Sequencer

Connect the devices as shown below, then get the sequencer ready for receiving SysEx messages.

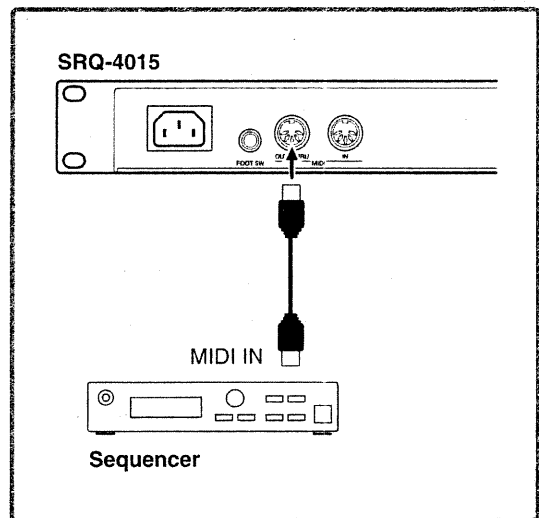

Read the instructions in the manual of the sequencer you are using.

Remote Control

1. Together press both [SHIFT] and [SYSTEM].
[SYSTEM] lights in green, and the "SYSTEM SETTING" screen appears.
2. Turn [VALUE] to select "MIDI," then press [VALUE].
The "MIDI" screen appears.

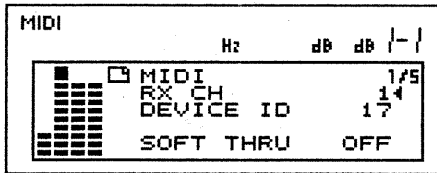

3. Turn [VALUE] to select "BULK DUMP," then press [VALUE].
4. Turn [VALUE] to select the data you wish to transmit, then press [VALUE].



Settings to be sent

- **"1-1" - "4-4"**
Transfers the settings of the selected memory number
- **TEMP**
Transfers the settings of the memory currently recalled (Play Mode)
- **SYS**
Transfers all system settings other than the settings stored at memory (p. 31)
- **ALL**
Transfer all settings

5. Set the sequencer to Recording mode.
6. Turn [VALUE] to select "TRANSMIT," then press [VALUE].
Data transfer begins.
After the data transfer has been completed, the display returns to its previous state.
7. Set the sequencer to Stop mode.

When you press [CH3] ([SYSTEM]), the "NOW WORKING KEEP POWER ON" message appears in the display, and the settings are placed in effect. Then the "SYSTEM SETTING" screen reappears.

Together press both [SHIFT] and [SYSTEM] (or press [CH3] ([SYSTEM]) twice) to go to the Play Mode.

Copying Data to Another SRQ-4015

Connect the devices as shown below.

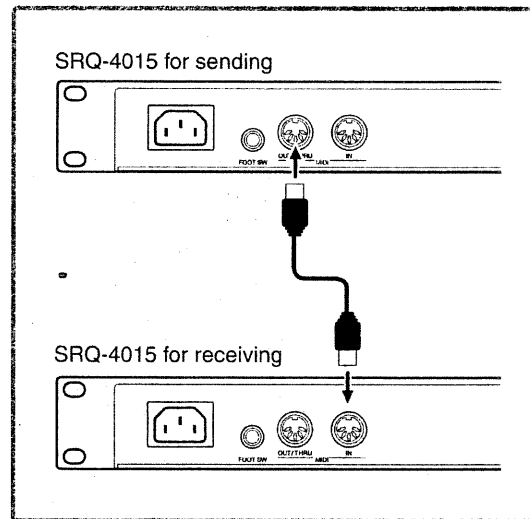

1. Together press both [SHIFT] and [SYSTEM].
[SYSTEM] lights in green, and the "SYSTEM SETTING" screen appears.
2. Turn [VALUE] to select "MIDI," then press [VALUE].
The "MIDI" screen appears.

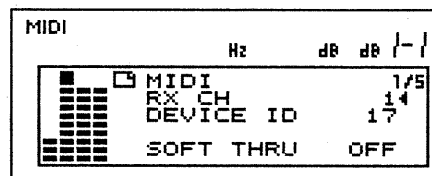

3. Turn [VALUE] to select "DEVICE ID," then press [VALUE].
4. Turn [VALUE] to select the device ID number, then press [VALUE].

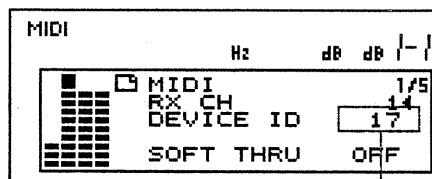

Device ID



Make sure that the ID numbers of both SRQ-4015s correspond to each other.

5. Turn [VALUE] to select "BULK DUMP," then press [VALUE].
6. Turn [VALUE] to select the data you wish to transmit, then press [VALUE].

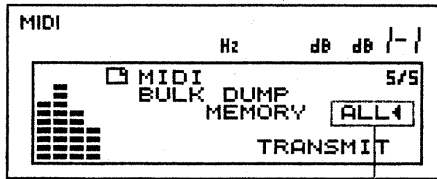

Settings to be sent

- "1-1" - "4-4"
Transfers the settings of the selected memory number
 - **TEMP**
Transfers the settings of the memory currently recalled (Play Mode)
 - **SYS**
Transfers all system settings other than the settings stored at memory (p. 31)
 - **ALL**
Transfer all settings
7. Turn [VALUE] to select "TRANSMIT," then press [VALUE].
Data transfer begins.
After the data transfer is complete, the display returns to its previous state.

When you press [CH3] ([SYSTEM]), the "NOW WORKING KEEP POWER ON" message appears in the display, and the settings are placed in effect. Then the "SYSTEM SETTING" screen reappears.
Together press both [SHIFT] and [SYSTEM] (or press [CH3] ([SYSTEM]) twice) to go to the Play Mode.

Receiving Settings (BULK LOAD)

Connect the devices as shown below, and set the same ID to this unit as that used when you saved data to the sequencer. (p. 38)

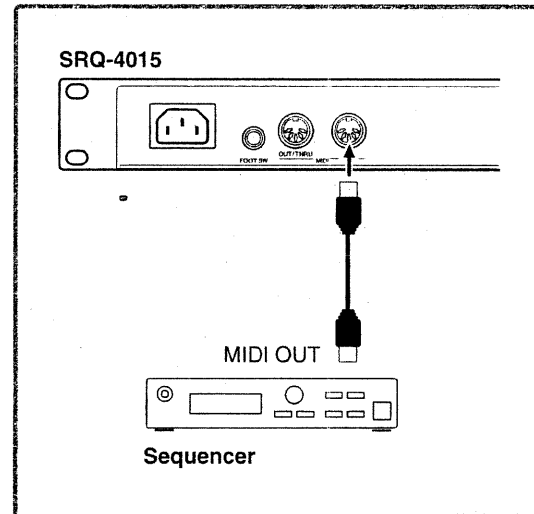

Read the instructions in the manual of the sequencer you are using.

1. Set the sequencer to the Play Mode.
Data transfer begins.
During transfer, "O" blinks at the MIDI signal transmit indicator in the LCD display. If you are receiving ALL or "1-1"-"4-4" setting data, the "MSR RECEIVED KEEP POWER ON" message (p. 40) appears in the display after data transfer is complete.
After data transfer is complete, the display returns to its previous state.
2. Set the sequencer to Stop mode.



During reception of SysEx Messages, all controls of the SRQ-4015 are disabled.

Reference

Troubleshooting

If you encounter problems with the operation of the SRQ-4015, first check the following points.

If these instructions still do not resolve your problems, consult your nearest Roland Service Center or an authorized Roland distributor.

There is No Sound or the Sound is Too Low

- **Is there a break in the cable?**
 - Try replacing the connected cable.
- **Is the SRQ-4015 properly connected to other MIDI devices?**
 - Check the connections. (p. 10)
- **Is the volume of the connected device turned down?**
 - Check the settings of the connected device.
- **Is the [INPUT LEVEL] knob turned down?**
 - Set [INPUT LEVEL] to the appropriate position. (p. 14)
- **Is the NOISE GATE turned on?**
 - Try turning the NOISE GATE off. (p. 29)
- **Is "OUTPUT" set to "-INF" or to a low position?**
 - Increase the output level. (p. 14)
- **Are you using a cable that contains a resistor?**
 - Use a connection cable that does not contain a resistor (Roland PCS Series, etc.).

The Sound is Distorted

- **Is the Output Level of the connected device too high?**
 - Adjust the output of the connected device to a more suitable level.
- **Is the Input Level knob set at an appropriate position?**
 - Set the input level to the appropriate position. (p. 14)

MIDI Messages Are Not Being Received

- **Could there be a break in the MIDI cable?**
 - Try replacing the MIDI cable.
- **Is the SRQ-4015 properly connected to other MIDI devices?**
 - Check the connections to the MIDI devices. (p. 37)
- **Do the MIDI channel numbers on the SRQ-4015 correspond to those on the other MIDI devices?**
 - Set the same MIDI channel numbers to those corresponding devices. (p. 35)
- **If you are Bulk Loading from another SRQ-4015, are the device ID numbers set to the same?**
 - Set the same ID number for both units. (p. 38)

Display Messages

This is a list of messages that may be displayed to prevent serious accidents, when there is an operational malfunction, or if a procedure is not properly executed. Respond as indicated in the messages.

"NOW WORKING KEEP POWER ON"

Appears when saving a setting to the unit.

Response: Do not turn off the power while displayed. If you do, the unit may return to the initial factory setting.

"PARAMETER ERROR!! NOW LOADING PRESET"

Cause: The unit was turned off while the "KEEP POWER ON" message was on display. The unit is loading the initial factory setting while this message is displayed for about 20 seconds.

Response: After the initializing is finished, the unit starts up as usual. You can now use it again.

"MIDI ERROR!! BUFFER FULL"

Cause: More MIDI messages were received at once than the SRQ-4015 was able to process.

Response: Reduce the amount of MIDI messages that are being transmitted to the SRQ-4015.

"MSR RECEIVED KEEP POWER ON"

Indicates that MSR messages have been successfully received during BULK LOAD.

("MSR:MEMORY SAVE REQUEST" For close information, refer to a separately sold MIDI Implementations document.)

Response: Do not turn off the power while displayed. If you do, the unit may return to the initial factory setting.

Equalizer Characteristics

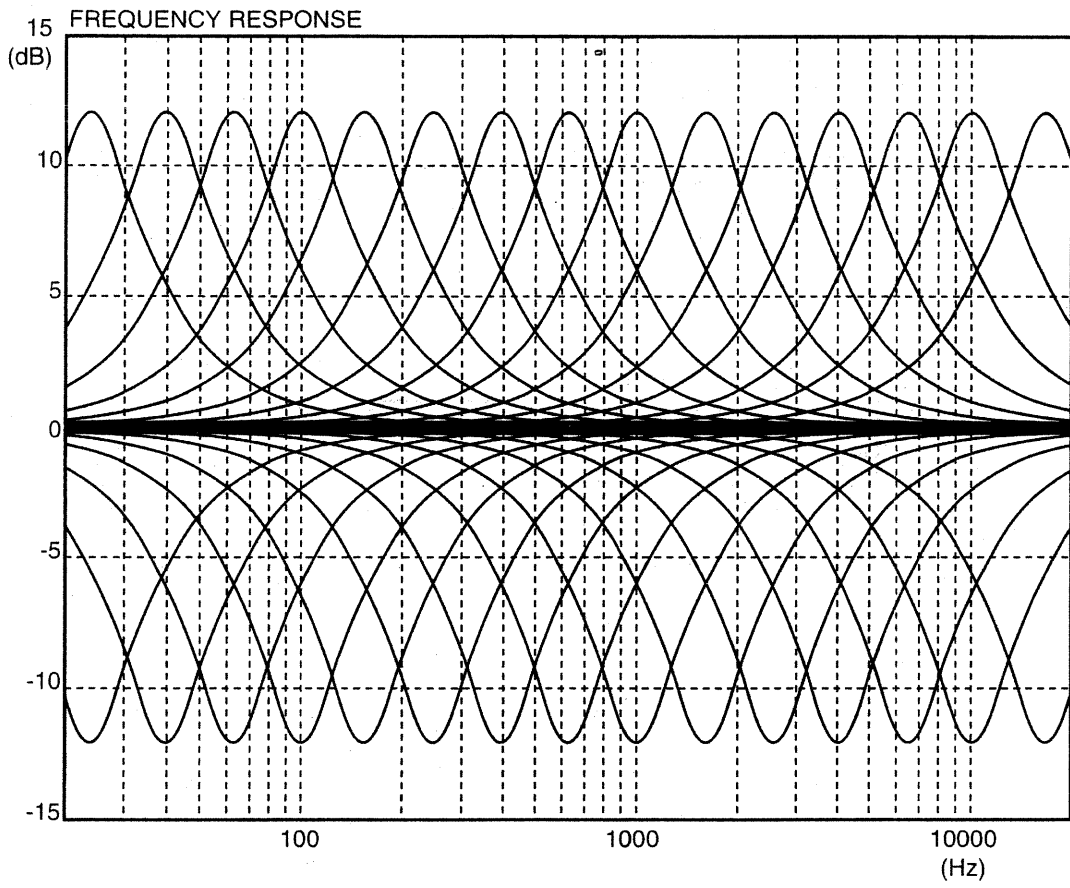

User Interface Guide

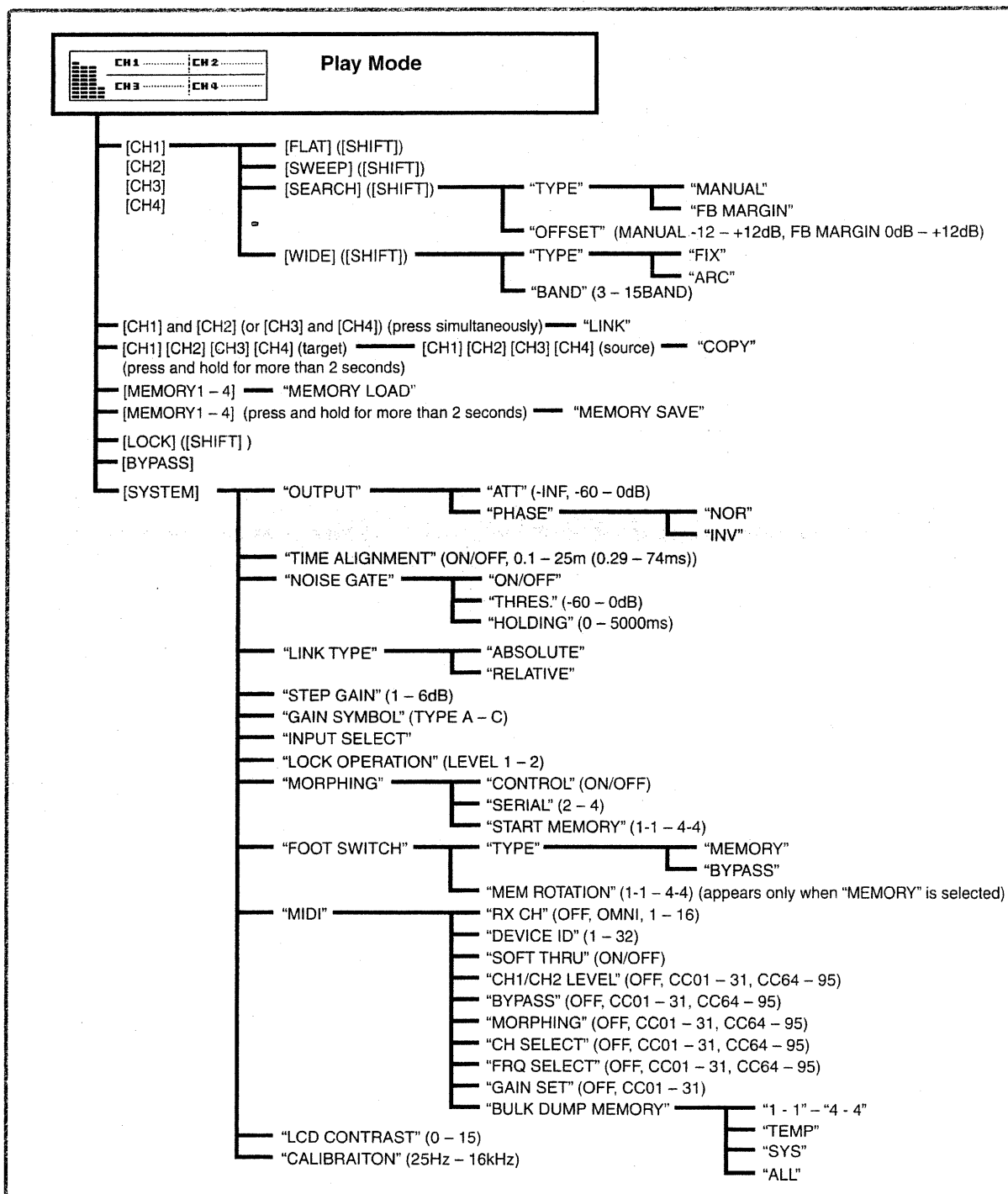

Characters and numbers enclosed in square brackets [] (for example [SYSTEM]) indicate buttons and knobs on the front panel.

Characters and numbers enclosed in double quotation marks " " (for example "MIDI") indicate the editing mode names shown in the display.

MIDI Implementation Chart

Date : Jun. 07, 2000 Version : 1.00

Function...	Transmitted	Recognized	Remarks
Basic Default Channel Changed	X X	1-16 1-16	Can be memorized after powering off.
Mode Default Messages Altered	X X *****	OMNI ON/OFF X X	Can be memorized after powering off.
Note Number : True Voice	X *****	X X	
Velocity Note On Note Off	X X	X X	
After Key's Touch Channel's	X X	X X	
Pitch Bend	X	X	
Control 1 - 31 Change 33 - 63 64 - 95	X X X	O O O *2 *1 *2 *1	
Program Change : True Number	O *****	O 0-15	User memory 1-1 to 4-4
System Exclusive	O	O	
System : Song Position Common : Song Select : Tune Request	X X X	X X X	
System : Clock Real Time : Commands	X X	X X	
Aux : All Sound Off Messages : Reset All Controllers : Local On/Off : All Notes Off : Active Sensing : System Reset	X X X X X X	X X X X X X	
Notes	* 1 LSB for controller number 1 - 31 * 2 Recognize messages for controlling parameters		

Mode 1 : OMNI ON, POLY
Mode 3 : OMNI OFF, POLYMode 2 : OMNI ON, MONO
Mode 4 : OMNI OFF, MONOO : Yes
X : No

A separate publication titled "MIDI Implementation" is also available. It provides complete details concerning the way MIDI has been implemented on this unit. If you should require this publication (such as when you intend to carry out byte-level programming), please contact the nearest Roland Service Center or authorized Roland distributor.

Block Diagram

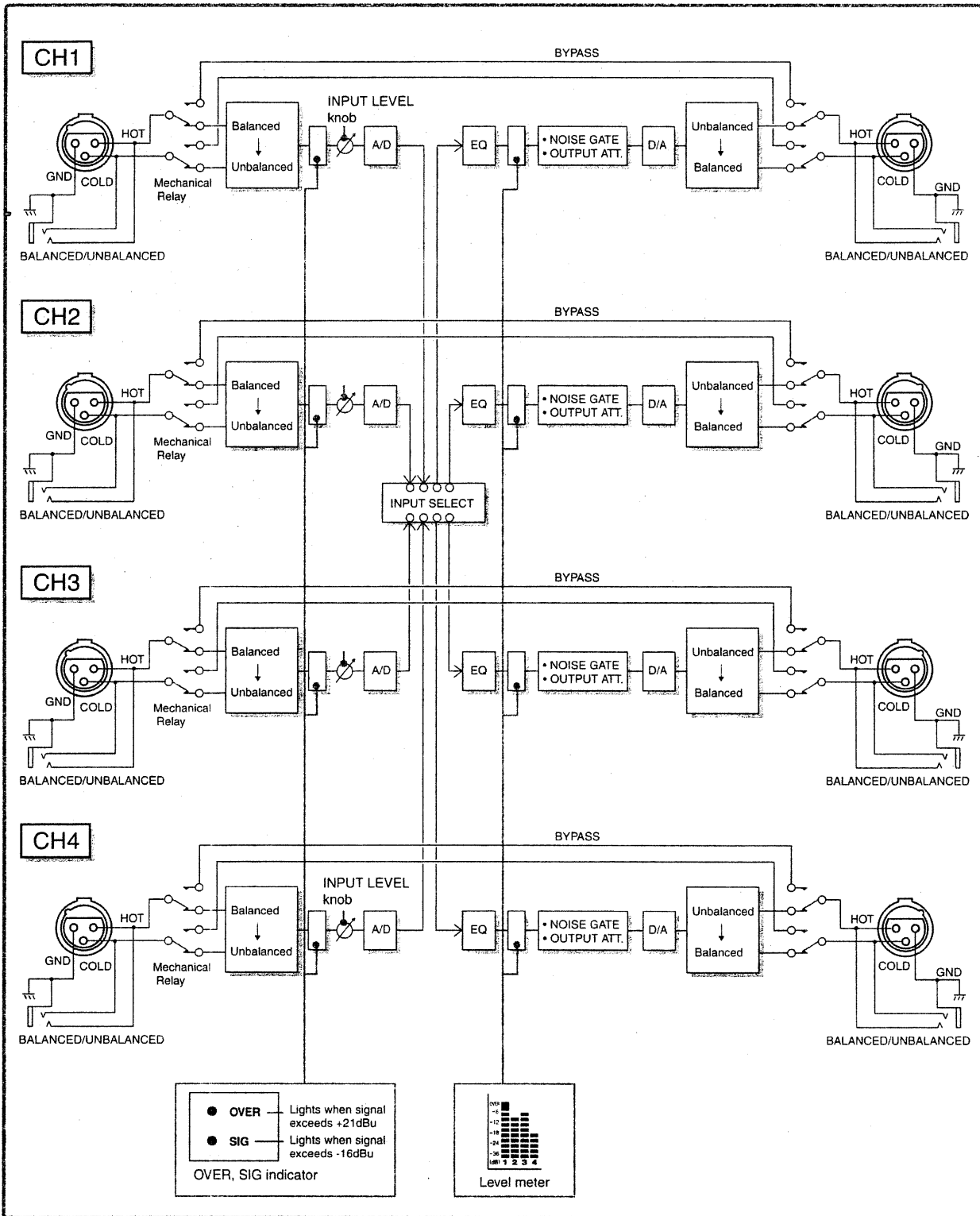

Specification

- **AD Conversion**
24 bits (64 times oversampling)
- **DA Conversion**
24 bits (128 times oversampling)
- **Sampling Frequency**
44.1 kHz
- **Program memory**
16 memories
- **Frequency Response**
20 Hz to 20 kHz -1 / +0 dB
- **Nominal Input Level**
+4 dBu
- **Input Impedance**
10 k ohms (HOT-COLD)
10 k ohms (HOT-GND, COLD-GND)
- **Nominal Output Level**
+4 dBu
- **Non-clipping Maximum Input Level**
+21 dBu
- **Non-clipping Maximum Output Level**
+21 dBu
- **Output Impedance**
600 ohms (HOT-COLD)
300 ohms (HOT-GND, COLD-GND)
- **Recommended Load Impedance**
Balanced Output: 6 k ohms or greater
Unbalanced Output : 3 k ohms or greater
- **Total Harmonic Distortion**
0.05 % or less (1kHz; level control: +/- 0 dB; equalizer level: +/- 0 dB)
- **Residual Noise Level**
-80 dBu (IHF-A; level control: +/- 0 dB; equalizer level: +/- 0 dB, typ.)
- **Equalizer Control**
Center Frequency: 25, 40, 63, 100, 160, 250, 400, 630, 1k, 1.6k, 2.5k, 4k, 6.3k, 10k, 16k [Hz]
Variable Range : +/- 12dB, -60dB

Controls

- Frequency slider
- VALUE/BANK (PUSH ENTER) knob
- CH1, CH2, CH3 (SYSTEM), CH4 (LOCK), BYPASS, FLAT (MEMORY1), SEARCH (MEMORY2), SWEEP (MEMORY3), WIDE (MEMORY4), SHIFT button
- INPUT LEVEL knob (CH1, CH2, CH3, CH4)
- Power Switch

Indicators

- Peak Indicator
- Signal Indicator
- Bypass Indicator

Display

- Graphic LCD (Back Light)

Connectors

- Input Connector (XLR type, 1/4 inch phone type)
- Output Connector (XLR type, 1/4 inch phone type)
XLR type 1:GND, 2:HOT, 3:COLD
phone type T:HOT, R:COLD, S:GND
- FOOT SW Jack
- MIDI connector (IN, OUT/THRU)

Power Supply

- AC 117 V, AC 230 V or AC 240 V

Power Consumption

- 7 W (AC 117 V), 9 W (AC 230 V), 9 W (AC 240 V)

Dimensions

- 482.0 (W) x 222.0 (D) x 44.0 (H) mm
19 (W) x 8-3/4 (D) x 1-3/4 (H) inches
(EIA-1U rack mount type)

Weight

- 2.6 kg/ 5 lbs 12 oz

Accessories

- Owner's Manual
- Rubber Feet
- AC cord
- Rack Mount Washer (x4)

Options

- Foot Switch: FS-5U (BOSS)

* 0 dBu = 0.775 Vrms

* In the interest of product improvement, the specifications and/or appearance of this unit are subject to change without prior notice.

Index

A	
ABSOLUTE	22
ARC	26
B	
Bank	31-32
Block Diagram	44
BYPASS	16, 33
C	
CALIBRATION	18
Channel copy	22
Connections	10
D	
Data Transfer (BULK DUMP)	37
E	
Editing	23
Equalizer Characteristics	41
F	
FB MARGIN	25
Feedback Margin	25
Feedback Point	25
FIX	27
FLAT	24
Foot Switch	33
G	
GAIN SYMBOL	19
H	
HOLDING TIME	29
I	
Input Level	14
L	
LCD CONTRAST	19
LINK	21
LOCK	16
M	
MANUAL	24
MEMORY LOAD	32
MEMORY ROTATION	33
MEMORY SAVE	31
MIDI	34
MIDI Channel	34
MIDI Implementation Chart	43
MORPHING	27
N	
NOISE GATE	29
O	
Output Level	14
P	
PHASE	15
Play Mode	23
R	
Receiving data (BULK LOAD)	39
RELATIVE	22
S	
SEARCH	24
Specification	45
STEP GAIN	17
System Parameter	17
T	
THRESHOLD	29
TIME ALIGNMENT	30
TOTAL CUT	28
Troubleshooting	40
TRS standard plug	9
Turning On the Power	13
U	
UNDO/REDO	30
User Interface Guide	42
W	
WIDE	26

Information

When you need repair service, call your nearest Roland Service Center or authorized Roland distributor in your country as shown below.

AFRICA

EGYPT

Al Fanny Trading Office
P.O. Box 2904,
El Horrieh Heliopolis, Cairo,
EGYPT
TEL: (02) 4185531

REUNION

Maison FO - YAM Marcel
25 Rue Jules Merman, ZI
Chaudron - BP79 97491
Site Clotilde REUNION
TEL: 28 29 16

SOUTH AFRICA

That Other Music Shop
(PTY) Ltd.
11 Melle Street (Cnr Melle and
Juta Street)
Braamfontein, 2001,
Republic of SOUTH AFRICA
TEL: (011) 405 4105

Paul Bothner (PTY) Ltd.
17 Werdmuller Centre Claremont
7700
Republic of SOUTH AFRICA

P.O. Box 23022
Claremont, Cape Town
SOUTH AFRICA, 7735
TEL: (021) 64 4030

ASIA

CHINA

Beijing Xinghai Musical
Instruments Co., Ltd.
6 Huangmichang Chao Yang
District, Beijing, CHINA
TEL: (010) 6774 7491

HONG KONG

Tom Lee Music Co., Ltd.
Service Division
22-32 Pun Shan Street, Tsuen
Wan, New Territories,
HONG KONG
TEL: 2415 0911

INDIA

Rivera Digitec (India) Pvt. Ltd.
409, Nirman Kendra Mahalaxmi
Flats Compound Off. Dr. Edwin
Moses Road, Mumbai-400011,
INDIA
TEL: (022) 498 3079

INDONESIA

PT Citra IntiRama
11, Cideng Timur No. 151-150
Jakarta Pusat
INDONESIA
TEL: (021) 6324170

KOREA

Cosmos Corporation
1461-9, Seocho-Dong,
Seocho Ku, Seoul, KOREA
TEL: (02) 3486-8855

MALAYSIA

Bentley Music SDN BHD
140 & 142, Jalan Bukit Bintang
55100 Kuala Lumpur, MALAYSIA
TEL: (03) 2443333

PHILIPPINES

G.A. Yupangco & Co. Inc.
339 Gil I. Puyat Avenue
Makati, Metro Manila 1200,
PHILIPPINES
TEL: (02) 899 9801

SINGAPORE

Sweet Lee Company
150 Sims Drive,
SINGAPORE 387381
TEL: 748-1669

CRISTOFORI MUSIC PTE LTD

BK 3014, Bedok Industrial Park E,
#02-2148, SINGAPORE 489980
TEL: 243 9555

TAIWAN

ROLAND TAIWAN
ENTERPRISE CO., LTD.
Room 5, 9th. No. 112 Chung Shan
N. Road Sec. 2, Taipei, TAIWAN,
R.O.C.
TEL: (02) 2561 3339

THAILAND

Theera Music Co., Ltd.
330 Veeng NakornKasem, Soi 2,
Bangkok 10100, THAILAND
TEL: (02) 2248821

VIETNAM

Saigon Music
138 Tran Quang Khai St.,
District 1
Ho Chi Minh City
VIETNAM
TEL: (08) 844-4068

AUSTRALIA/ NEW ZEALAND

AUSTRALIA

Roland Corporation
Australia Pty., Ltd.
38 Campbell Avenue
Dee Why West, NSW 2099
AUSTRALIA
TEL: (02) 9982 8266

NEW ZEALAND

Roland Corporation (NZ) Ltd.
97 Mt. Eden Road, Mt. Eden,
Auckland 3, NEW ZEALAND
TEL: (09) 3098 715

CENTRAL/LATIN AMERICA

ARGENTINA

Instrumentos Musicales S.A.
Florida 656 2nd Floor
Office Number 206A
Buenos Aires
ARGENTINA, CP1005
TEL: (54-11) 4- 392-6057

BRAZIL

Roland Brasil Ltda.
R. Coronel Octaviano da Silveira
203 05522-010
Sao Paulo BRAZIL
TEL: (011) 3743 9377

COSTA RICA

JUAN Bansbach
Instrumentos Musicales
Ave. 1, Calle 11, Apartado 10237,
San Jose, COSTA RICA
TEL: (506) 258-0211

CHILE

Comercial Fancy S.A.
Avenida Rancagua #0330
Providencia Santiago, CHILE
TEL: 56-2-373-9100

EL SALVADOR

OMNI MUSIC
75 Avenida Notre YY Alameda,
Juan Pablo 2, No. 4010
San Salvador, EL SALVADOR
TEL: (503) 262-0788

MEXICO

Casa Veerkamp, s.a. de c.v.
Av. Toluca No. 323, Col. Olivar
de los Padres 01780 Mexico D.F.
MEXICO
TEL: (525) 668 04 80

La Casa Wagner de
Guadalajara s.a. de c.v.
Av. Corona No. 202 S.J.
Guadalajara, Jalisco Mexico
C.P. 44100 MEXICO
TEL: (5) 613 1414

PANAMA

SUPRO MUNDIAL, S.A.
Boulevard Andrews, Albrook,
Panama City,
REP. DE PANAMA
TEL: (507) 315-0101

PARAGUAY

Distribuidora De
Instrumentos Musicales
J.E. Olear y ESQ. Manduvira
Edefeño, El Dorado Planta Baja
Asuncion PARAGUAY
TEL: 595-21-492147

PERU

VIDEO Broadcast S.A.
Portinari 199 (ESQ. HALS),
San Borja, Lima 41,
REP. OF PERU
TEL: 51-14-758226

URUGUAY

Todo Musica S.A.
Cuareim 1844, Montevideo,
URUGUAY
TEL: 5982-924-2335

VENEZUELA

Musiland Digital C.A.
Av. Francisco de Miranda,
Centro Parque de Cristal, Nivel
C2 Local 20 Caracas
VENEZUELA
TEL: (02) 285 9218

EUROPE

AUSTRIA

Roland Austria GES.M.B.H.
Simonsstrasse 4, P.O. Box 74,
A-6063 RUM, AUSTRIA
TEL: (0512) 26 44 200

BELGIUM/HOLLAND/ LUXEMBOURG

Roland Benelux N. V.
Houtstraat 3, B-2260, Oevel
(Westerlo) BELGIUM
TEL: (014) 575811

DENMARK

Roland Scandinavia A/S
Nordhavnsvej 7, Postbox 888,
DK-2100 Copenhagen
DENMARK
TEL: (039) 116 6200

FRANCE

Roland France SA
4, Rue Paul Henri SPAAK,
Parc de l'Esplanade, F 77 462 St.
Thibault, Lagny Cedex FRANCE
TEL: 01 600 73 500

FINLAND

Roland Scandinavia As,
Filial Finland
Lauttasaarentie 51 B
Fin-00201 Helsinki, FINLAND
TEL: (9) 682 4020

GERMANY

Roland Elektronische
Musikinstrumente HmbH.
Oststrasse 96, 22844 Norderstedt,
GERMANY
TEL: (040) 52 60090

GREECE

STOLLAS S.A.
Music Sound Light
135, New National Road
26422 Patras, GREECE
TEL: 061-435400

HUNGARY

Intermusica Ltd.
Warehouse Area 'DEPO' Pf.83
H-2046 Torokbalint, HUNGARY
TEL: (23) 511011

IRELAND

Roland Ireland
Audio House, Belmont Court,
Donnybrook, Dublin 4,
Republic of IRELAND
TEL: (01) 2603501

ITALY

Roland Italy S. p. A.
Viale delle Industrie 8,
20020 Arese, Milano, ITALY
TEL: (02) 937-78300

NORWAY

Roland Scandinavia Avd.
Kontor Norge
Lilleakerveien 2 Postboks 95
Lilleaker N-0216 Oslo
NORWAY
TEL: 273 0074

POLAND

P. P. H. Brzostowicz
U.L. Gibraltarska 4,
PL-03664 Warszawa POLAND
TEL: (022) 679 44 19

PORTUGAL

Tecnologias Musica e Audio,
Roland Portugal, S.A.
RUA DE SANTA CARARINA
131/133, 4000-450 PORTO
PORTUGAL
TEL: (022) 208 4456

ROMANIA

FBS LINES
Plata 1 libertatii 1,
RO-1200 Cheorgheni
TEL: (066) 164 609

RUSSIA

Slami Music Company
Sadovaya-Triumfalnaja st., 16
103006 Moscow, RUSSIA
TEL: 095 209 2193

SPAIN

Roland Electronics
de España, S. A.
Calle Bolivia 239, 08020
Barcelona, SPAIN
TEL: (93) 308 1000

SWEDEN

Roland Scandinavia A/S
SWEDISH SALES OFFICE
Danvik Center 28, 2 tr.
S-131 30 Nacka SWEDEN
TEL: (08) 702 0020

SWITZERLAND

Roland (Switzerland) AG
Musitronic AG
Gerberstrasse 5, CH-4410 Liestal,
SWITZERLAND
TEL: (061) 921 1615

UKRAINE

TIC-TAC
Mira Str. 19/108
P.O. Box 180
295400 Munkachevo, UKRAINE
TEL: (03131) 414-40

UNITED KINGDOM

Roland (U.K.) Ltd.
Atlantic Close, Swansea
Enterprise Park, SWANSEA
SA7 9FJ,
UNITED KINGDOM
TEL: (01792) 700139

MIDDLE EAST

BAHRAIN

Moon Stores
Bab Al Bahrain Road,
P.O. Box 20077
State of BAHRAIN
TEL: 211 005

CYPRUS

Radex Sound Equipment Ltd.
17 Dingorou St., P.O. Box 2046,
Nicosia CYPRUS
TEL: (02) 453 426

ISRAEL

Haliit P. Greenspoon &
Sons Ltd.
8 Retzif Fa'aliya Hashvya St.
Tel-Aviv-Yahoe ISRAEL
TEL: (03) 6823666

JORDAN

AMMAN Trading Agency
Prince Mohammed St. P.O. Box
825 Amman 1118 JORDAN
TEL: (06) 4641200

KUWAIT

Easa Husain Al-Yousifi
Abdullah Salem Street,
Satal KUWAIT
TEL: 5719499

LEBANON

A. Chahine & Fils
P.O. Box 16-5857 Gergi Zeidan St.
Chahine Building, Achrafieh
Beirut, LEBANON
TEL: (01) 335799

QATAR

Badie Studio & Stores
P.O. Box 62,
DOHA QATAR
TEL: 423554

SAUDI ARABIA

aDawlah Universal
Electronics APL
P.O. Box 2154 ALKHOBAR 31952,
SAUDI ARABIA
TEL: (03) 898 2081

SYRIA

Technical Light & Sound
Center
Khaled Ibn Al Walid St.
P.O. Box 13520
Damascus - SYRIA
TEL: (011) 2235 384

TURKEY

Barkat muzik aletleri ithalat
ve ihracat Ltd Sti
Sirasiviler cad. Guney is hani 84
86/6, Taksim, Istanbul, TURKEY
TEL: (0212) 2499324

U.A.E.

Zak Electronics & Musical
Instruments Co. L.L.C.
Zabeel Road, Al Sherooq Bldg.,
No. 14, Grand Floor DUBAI
U.A.E.
TEL: (04) 3360715

NORTH AMERICA

CANADA

Roland Canada Music Ltd.
(Head Office)
5480 Parkwood Way, Richmond
B. C., V6V 2M4 CANADA
TEL: (0604) 270 6626

Roland Canada Music Ltd.

(Toronto Office)
Unit 2, 109 Woodbine Downs
Bldv, Etobicoke, ON
M9W 6Y1 CANADA
TEL: (0416) 213 9707

U. S. A.

Roland Corporation U.S.
5100 S. Eastern Avenue
Los Angeles, CA 90040-2938,
U. S. A.
TEL: (323) 890 3700

As of June 1, 2000 (Roland)



For EU Countries

This product complies with the requirements of European Directives EMC 89/336/EEC and LVD 73/23/EEC.

For the USA

FEDERAL COMMUNICATIONS COMMISSION RADIO FREQUENCY INTERFERENCE STATEMENT

This equipment has been tested and found to comply with the limits for a Class B digital device, pursuant to Part 15 of the FCC Rules. These limits are designed to provide reasonable protection against harmful interference in a residential installation. This equipment generates, uses, and can radiate radio frequency energy and, if not installed and used in accordance with the instructions, may cause harmful interference to radio communications. However, there is no guarantee that interference will not occur in a particular installation. If this equipment does cause harmful interference to radio or television reception, which can be determined by turning the equipment off and on, the user is encouraged to try to correct the interference by one or more of the following measures:

- Reorient or relocate the receiving antenna.
- Increase the separation between the equipment and receiver.
- Connect the equipment into an outlet on a circuit different from that to which the receiver is connected.
- Consult the dealer or an experienced radio/TV technician for help.

Unauthorized changes or modification to this system can void the users authority to operate this equipment.
This equipment requires shielded interface cables in order to meet FCC class B Limit.

For Canada

NOTICE

This Class B digital apparatus meets all requirements of the Canadian Interference-Causing Equipment Regulations.

AVIS

Cet appareil numérique de la classe B respecte toutes les exigences du Règlement sur le matériel brouilleur du Canada.

Additions to the SRQ-4015 Owner's Manual

The text in this supplement was mistakenly omitted from the SRQ-4015 Owner's Manual. Please add the following sentences where indicated. We apologize for any inconvenience.

Add the following sentence to "Turning On the Power" (p. 13)

- Upon power-up, Memory Number "1-1" is automatically called up.

Add the following sentence to "Turning Off the Power" (p. 13)

- Settings in effect at the time the power is turned off will be discarded. If you want to retain your settings, you need to save them before turning off the power (p. 31).

Add the following sentences to "To Store the Current Settings" (p. 31)

- Upon power-up, Memory Number "1-1" is automatically called up. If you have settings that you want to have called up automatically each time the power is turned on, you can save them at Memory "1-1."

 Roland®

71678234

UPC

71678234



10901

Roland