

RCL-10

COMPRESSOR

LIMITER

Owner's Manual



RCL-10 COMPRESSOR LIMITER

INSTRUCTIONS

• Please read the instructions carefully.

FEATURES

The Dynamics Processor RCL-10 has Compressor, Limiter, Expander, and more, Noise Gate functions. Adopting a high quality VCA, the RCL-10 allows high SN ratio, low harmonic distortion and little tone quality deterioration. Each control can be used to present various effects. The Key In Jack allows to change the response depending on the type of input signal, and the Stereo Link Jack allows connection of two sets of RCL-10's for synchronization. The RCL-10 is one of the Micro Studio Series, and by using the Rack Mount Adaptor (optional), any two of the Series can be mounted on the standard 19" rack (EIA-1U).

FUNCTIONS

The RCL-10 has four functions; Compressor, Limiter, Expander and Noise Gate.

«Compressor/Limiter»

Both are the functions of compressing the input signal, but different in the threshold level (*1) and ratio (*2) settings. Compressor is used to compress the signal of a wide dynamic range and even the level. Limiter is a stronger function that is used to protect a unit from excessive input or to reduce sound distortion.

«Expander»

This is the function of widening the dynamic range of input signal. Use this to make a dynamic sound.

Threshold Level (*1)

This is the level at which the compressor or limiter starts the compressing procedure. The signal lower than the threshold level will pass through without being compressed.

Ratio (*2)

This is the compression ratio to the input level. For instance, when a 10 dB signal is fed in and 5dB level signal is sent out, the ratio will be 10dB : 5dB = 2 : 1.

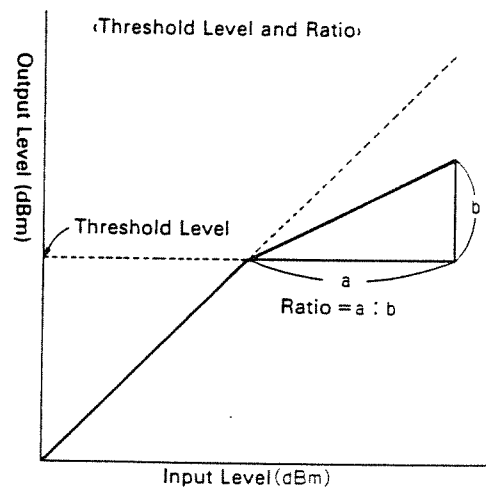

Attack Time

This is the time needed for the ratio of the signal over the threshold level to reach the set ratio.

Release Time

This is the time required for the signal that has become under the threshold level (= the signal that stops compressing) to reach the normal level.

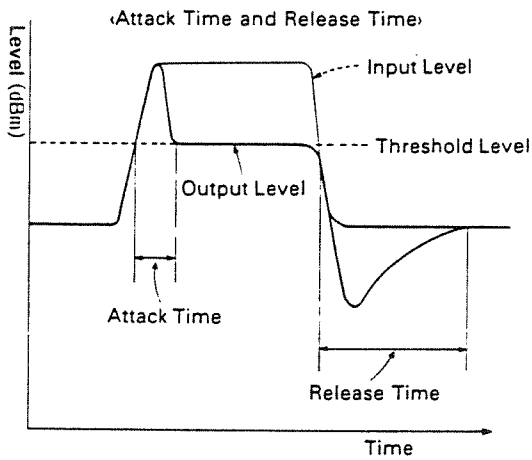

● Control Setting Examples

	Threshold	Ratio	Attack Time	Release Time
Limitter	Fairly High	$\infty : 1 \sim 8 : 1$	Fairly Short	Fairly Short
Compressor	Fairly Low	$8 : 1 \sim 1 : 1$	Slightly Long	Slightly Long
Expander		$1 : 1 \sim 1 : 1.5$	Fairly Short	Fairly Short

《Noise Gate》

This serves to mute the signal that is lower than the set level (threshold level). Therefore, it can be effectively used for removing noise when nothing is being played, or reducing the crosstalk when several microphones are used.

Threshold Level

The signal lower than this level will be muted.

Decay Time

This is the time spent for the muting.

PANEL DESCRIPTIONS

< FRONT PANEL >

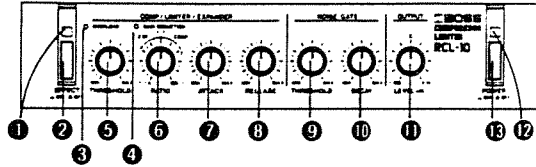

1 EFFECT INDICATOR

This lights up when the effect is turned on. So you can easily see whether the unit is in the Normal or Effect mode.

2 EFFECT SWITCH

Each time this switch is pushed, the unit is alternately turned to the Effect and Normal modes.

3 OVERLOAD INDICATOR

When the signal fed into the unit is too high, this indicator lights up. If it lights up too often, lower the input level of the connected unit, or set the Level Switch (15) to the "-10dBm" position.

4 GAIN REDUCTION INDICATOR

In the compressor or limiter mode, this lights up when the unit is operating. So, this can be an aid for setting the threshold level. In the expander mode, this lights up when the unit is not operating, and goes out when operating.

5 THRESHOLD

This decides the threshold level (the level where the compressor starts working). Rotating it clockwise will increase the level, making the effect of the compressor/limiter weaker.

* In Expander mode (when the ratio is 1 : 1.5 to 1 : 1), this knob has no effect.

6 RATIO

This adjusts the compression ratio. When it is rotated clockwise from the center position (1 : 1 to ∞ : 1), the RCL-10 functions as compressor/limiter. And when rotated counterclockwise (1 : 1 to 1 : 1.5), it functions as an expander. At its center position, the compression ratio is 1 : 1, therefore none of the compressor, limiter or expander works.

7 ATTACK

This adjusts the attack time. Rotating this clockwise will make the attack time longer.

8 RELEASE

This adjusts the release time. Rotating it clockwise will make the release time longer.

9 THRESHOLD

This decides the threshold level of the noise gate. Rotating the knob clockwise will increase the level. At its fully counterclockwise position, the noise gate function is not obtained at all.

10 DECAY

Decay Time is the time needed for the input signal under the set threshold level to finally fade out. Rotating the knob clockwise will make a longer decay time.

11 OUTPUT LEVEL

This adjusts the output level of the effect signal. When the ratio is 1 : 1, setting this knob to the center position will make the output and input levels equal.

12 POWER INDICATOR

This lights up when the unit is turned on.

13 POWER SWITCH

Push this switch to turn the unit on, and push it again to turn off.

< REAR PANEL >

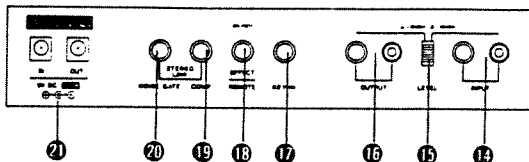

14 INPUT JACKS

Connect a musical instrument or audio equipment to this jack.

* The standard phone and pin jacks do not work at a time. If both are simultaneously used, the standard phone jack will have priority.

15 LEVEL SWITCH

Set this knob to an appropriate position depending on the output level of the connected device. "-20dBm" position may be selected for a usual electric musical instrument (such as an electric guitar).

16 OUTPUT JACKS

Connect a guitar amplifier or audio equipment, etc. Both pin and standard phone jacks can be simultaneously used.

17 KEY IN JACK

This is an input jack that can be used to change the response of each function of the RCL-10

depending on the external audio signal fed into (usually the input signal or the processed input signal).

18 EFFECT REMOTE JACK

Connect the footswitch FS-1 (optional) to this jack, and Effect/Normal mode can be selected without reaching out your hand.

* The above function cannot be obtained if the Effect Switch on the front panel is turned off. When two RCL-10's are setup, connect the Remote jacks of the two units, and Effect/Normal of the both units can be controlled by either of them.

19 STEREO LINK JACK (COMP)

By connecting two sets of the RCL-10 through these Stereo Link Jacks, they will have the same responses of the compressors, limiters and expanders. (See page 11).

20 STEREO LINK JACK (NOISE GATE)

By connecting two sets of the RCL-10 through these Stereo Link Jacks, they will have the same responses of the noise gate. (See page 12.)

21 AC ADAPTOR JACKS

This is to connect the AC Adaptor (BOSS PSA-120, 220 or 240). When using this unit to supply power to other BOSS Micro Studio Series, connect the supplied DC cord to "OUT". Otherwise use the "IN" jack.

* When only one AC adaptor is used for supplying power to more than one unit, please be sure that the total amount of the current draw does not exceed 200mA. (The current draw is shown on the rear panel of each unit.)

CONNECTIONS

AC Adaptor BOSS
PSA-120, 220 or 240.
(Optional)

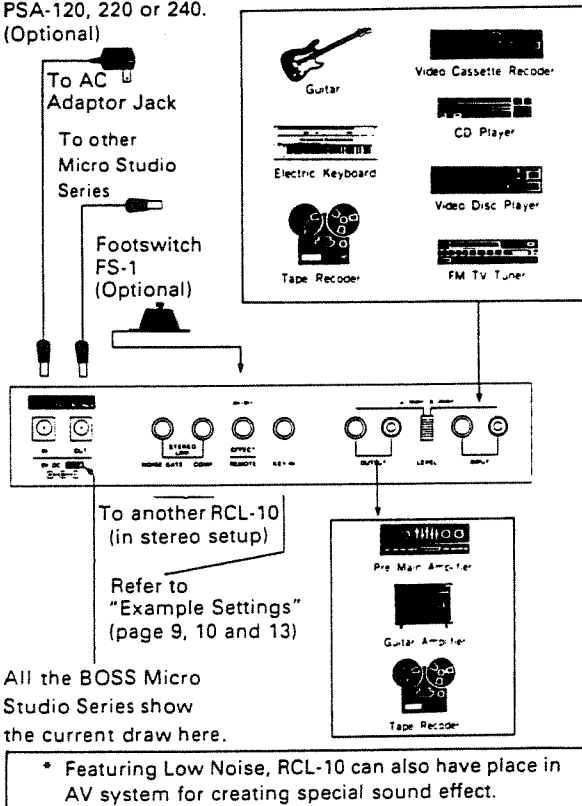

OPERATION

- 1 Set the Ratio Knob to 1:1 (center) position, the Threshold of Noise Gate to MIN, the Output Level to "0dB", and the Effect Switch to the OFF position.
- 2 Switch the RCL-10 on. (Make sure that the Power Indicator lights up.)
- 3 Set the Level Switch to either position depending on the type of the device you use.
 - * Changing the position of the Level Switch will not affect the volume.
- 4 Push the Effect Switch to turn the unit to the effect mode.
 - * When you connect a footswitch to the Effect Remote Jack, you can turn the unit to the effect or normal mode just by depressing the pedal.
 - * If the Effect Switch on the front panel has been turned off, above remote control function cannot be obtained.
- 5 Try moving each Control to see how it affects the tone color, then make your own sounds.

Example Settings (1)

RCL-10 as a Limiter

Set up the RCL-10 before a tape recorder, and clear sound without distortion can be recorded.

Set up the RCL-10 before an amplifier, and the speaker can be protected from an excessive strain by overloading.

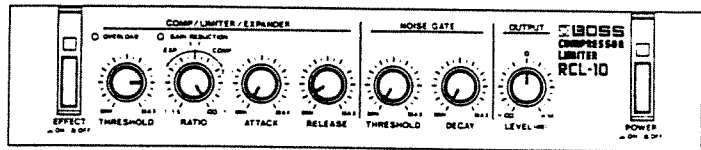

RCL-10 as a Compressor for vocal

Vocal has a very wide dynamic range, so it is usually difficult to record in low distortion and good SN ratio. In the setting as shown right, clear sound can be recorded and volume will increase, therefore the vocal will come forward.

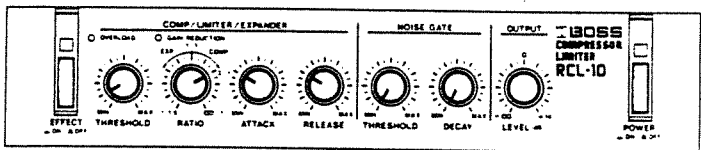

RCL-10 as a Compressor for guitar or bass guitar

By using the RCL-10 for guitar cutting, accurate and clear sound can be obtained. Also, by using it for bass chopper, the peak will be suppressed, allowing better band ensemble.

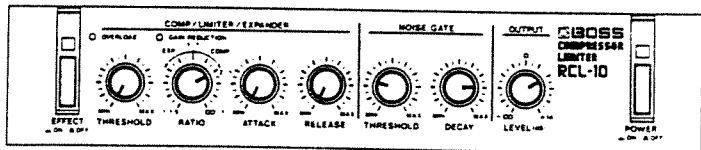

RCL-10 as an Expander

When recording drum voices, you may use the RCL-10 for tom. The recorded sound will be extremely dynamic.

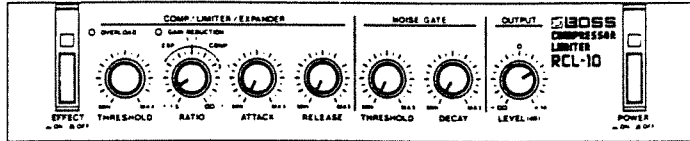

RCL-10 as a Noise Gate

In a setup using many effect units, noise will increase that much. Using the RCL-10 as a Noise Gate at the end of the group of the effect units will remove the undesired noise heard when nothing is being played.

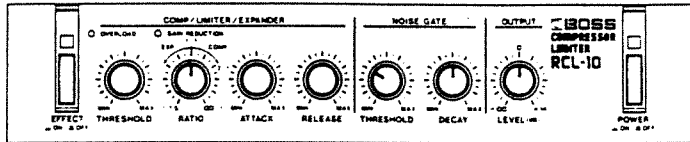

RCL-10 as a signal gate

When recording drum voices, use the RCL-10 for a bass drum and cut the unnecessary release time, and the recorded sound will be tight. Also by using it for a microphone, the crosstalk among the microphones can be reduced, and clear sound will be obtained.

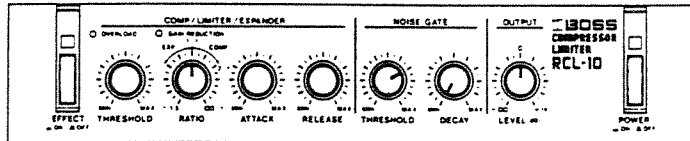

Example Settings (2)

The RCL-10 features a Key In Jack and Stereo Link Jacks, allowing wide variety of applications.

RCL-10 as a gate echo

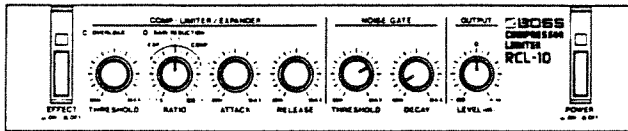

You can make gate echo sound which is often used for a snare drum.

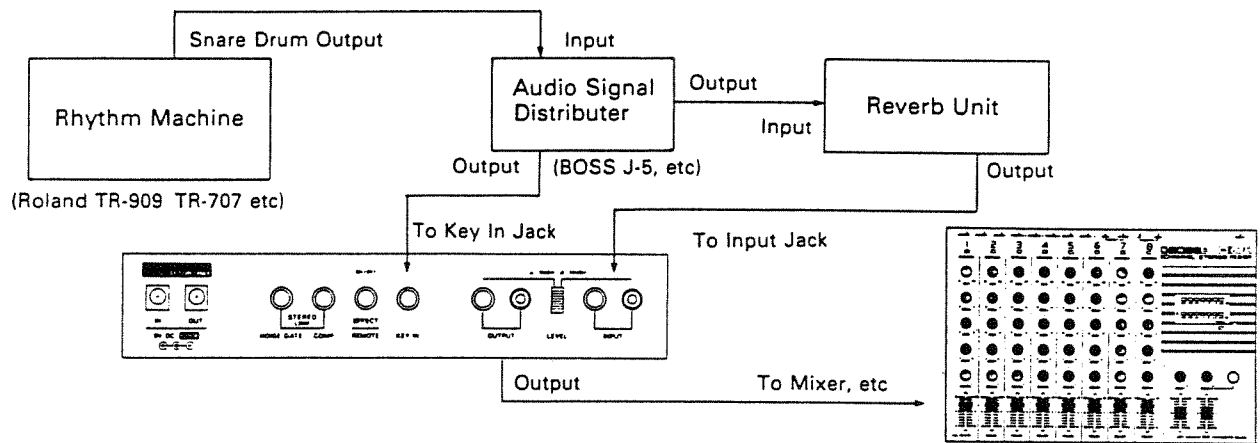

RCL-10 as a de-esser for vocal

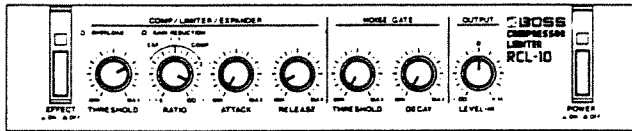

To make clearer vocal sound, you may boost the treble by using equalizer. This, however, inevitably emphasizes sibilant sounds. To resolve this problem, use the limiter on the band of 6kHz which contains sibilant sounds.

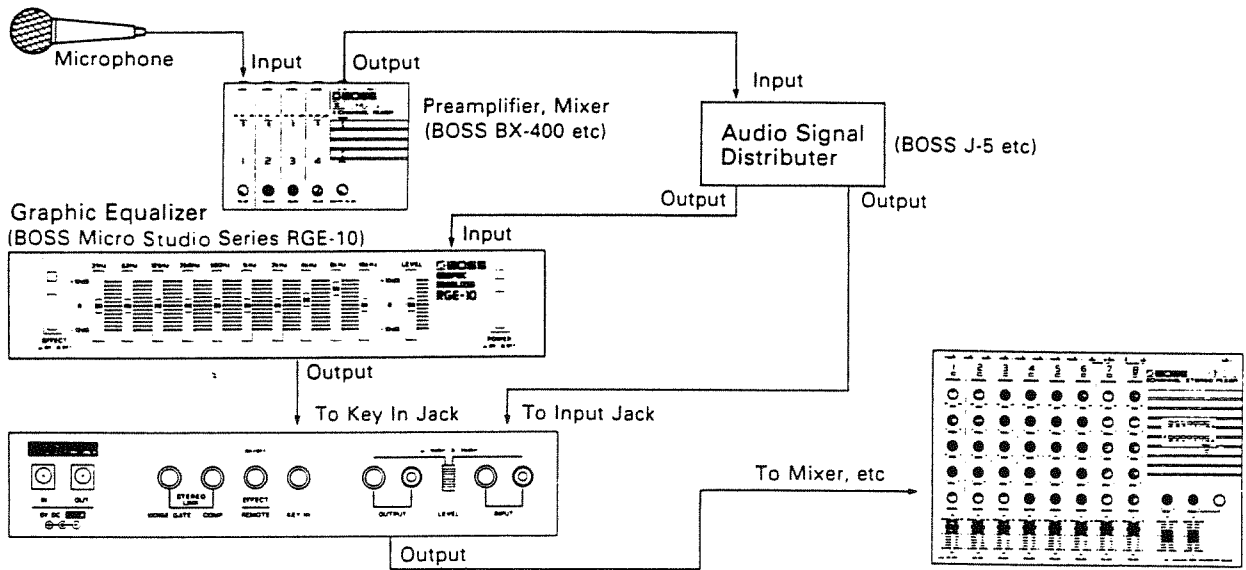

RCL-10 as a Limiter in stereo

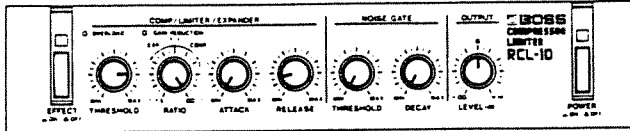

* Normally, set these two RCL-10's exactly the same. If they are set differently, the one with smaller amount of compression will synchronize to the other one.

By connecting two sets of the RCL-10 through the Stereo Link Jacks (COMP), they will have the same responses of the Compressors, Limiters and Expanders, therefore, even in stereo use, natural limiting effect can be obtained.

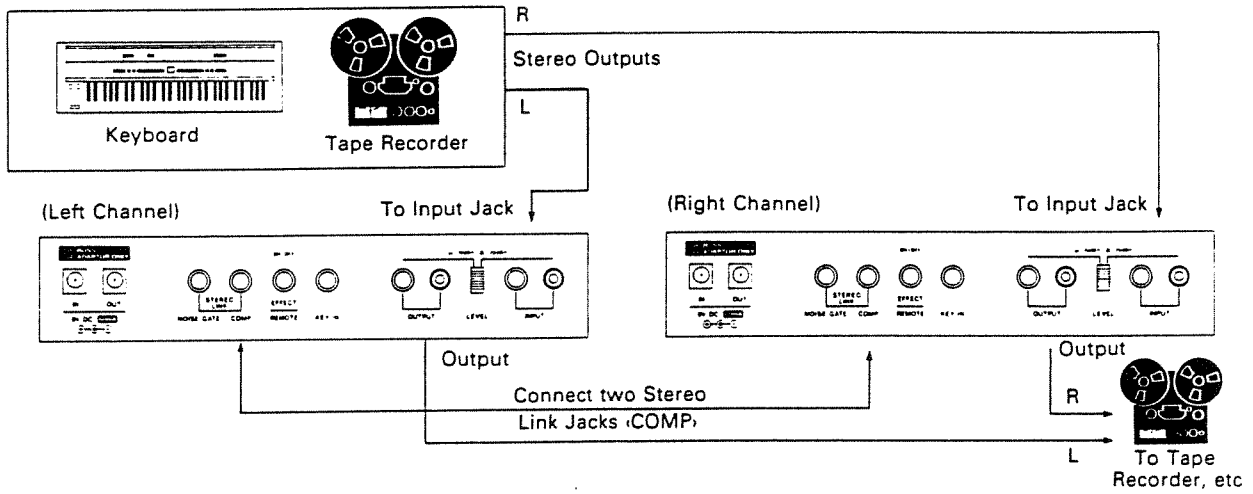

RCL-10 as a Noise Gate in stereo

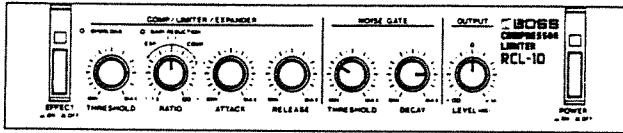

* Normally set these two RCL-10's exactly the same. If they are set differently, the one with smaller input level will synchronize to the other one.

Lately, more stereo-out effect units have been on the market, so you may sometimes want to use the Noise Gate in stereo. If so, connect two sets of the RCL-10's through the Stereo Links (NOISE GATE), and the responses of these two units will be the same. In this way, noise can be removed without spoiling natural impression.

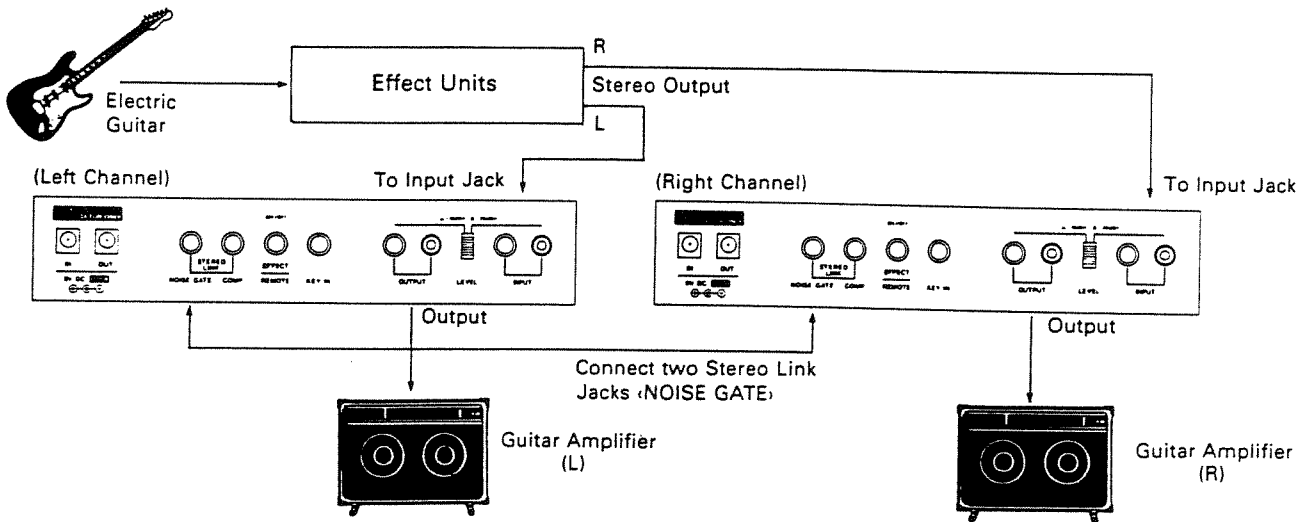

RCL-10 as an Expander for distortion sound

Example Settings

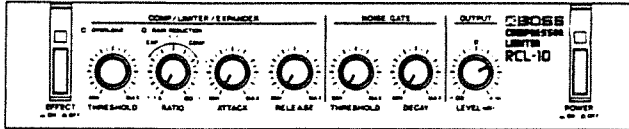

Expressing a delicate picking nuance in guitar's distortion sound is not an easy job. Using the RCL-10 as an Expander, however, a subtle nuance of picking can be expressed, reducing noise at a time. Also, by setting the release time fairly long, you can control the level of the distortion sound with the volume control of the guitar.

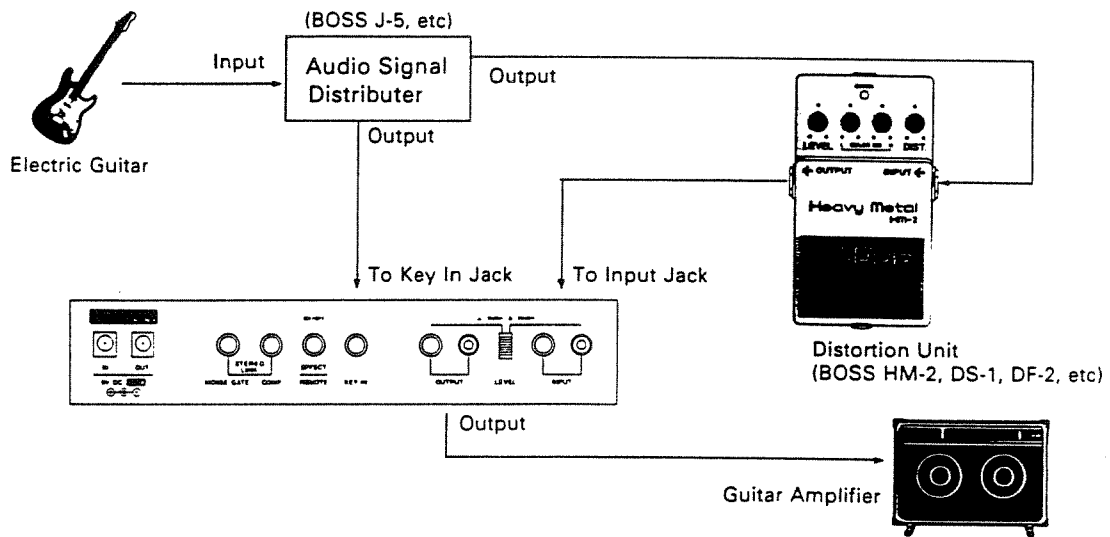

IMPORTANT NOTES

- Be sure to use the AC Adaptor BOSS PSA-120, 220 or 240 depending on the line voltage system in your country.
- When you use only an AC adaptor for supplying power to more than one unit, please be sure that the total current draw does not exceed 200mA. (The current draw of each unit is shown on its rear panel.)
- When the unit is not to be used for a long period of time, disconnect the AC adaptor from the wall socket.
- Avoid using the unit in extreme heat or humidity or where it may be affected by dust.
- Please never remove the cabinet from the body of the unit.
- When you use only Micro Studio Series without optional Rack Mount Adaptor "RAD-10", please attach the rubber feet. Refer to figure.

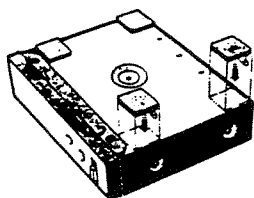

AC ADAPTOR BOSS PSA-120, 220 OR 240

Be sure to use the optional BOSS PSA series. Using any other adaptor will cause trouble.

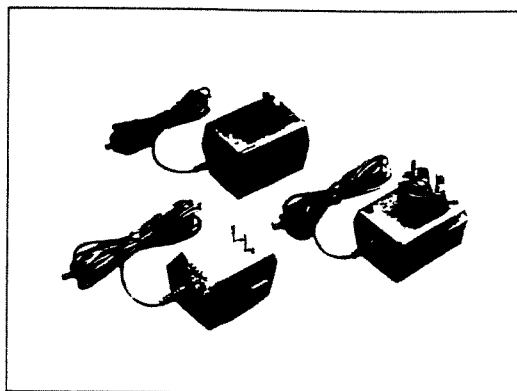

RACK MOUNT INSTALLATION

The RCL-10 is one of the BOSS Micro Studio Series, and by using the Rack Mount Adaptor RAD-10, any two sets of the Series can be mounted in a standard 19" rack (EIA-1U). Remove the rubber feet (x4) from the units, then attach the units to the Rack Mount Adaptor RAD-10, then mount the whole set in the rack.

SPECIFICATIONS

Input Level/Input Impedance: -20dBm/1M Ω ,
 -10dBm/47k Ω
Output Level/Output Impedance: -20dBm/2k Ω ,
 -10dBm/2k Ω
Output Load Impedance: over 10k Ω
Frequency Response: 10Hz to 25kHz (-3 ⁺⁰dB)
Residual Noise: under 95dBm
 (IHF-A, Level Switch set to -20dBm)
Compressor/Limiter/Expander
 • **Threshold:** -40dBm to 0dBm
 (Level Switch set to -20dBm)
 • **Ratio:** 1:1.5 to ∞ :1
 • **Attack:** 0.2ms to 50ms
 • **Release:** 50ms to 2s
Noise Gate
 • **Threshold:** - ∞ to -10dBm
 (Level Switch set to -20dBm)
 • **Decay:** 2ms to 5s
Output Gain: - ∞ to +14dB
THD: under 0.03%
Switches: Power
 Effect
 Level (-20dBm: -10dBm)
Jacks: Input (Standard Phone, Pin)
 Output (Standard Phone, Pin)
 Effect Remote (On/Off)
 Key In
 Stereo Link (COMP)
 Stereo Link (NOISE GATE)
 AC Adaptor (In, Out)

Indicators: Power
 Effect
 Overload
 Gain Reduction
Power: 9V DC (BOSS PSA-120, 220 or 240)
Current Draw: 60mA
Dimensions: 218(W) x 44(H) x 169(D) mm
 8-9/16"(W) x 1-3/4"(H) x 6-11/16"(D)
 900g/2 lb
Weight:
Accessory: DC Cord (0.5m)
OPTIONS: AC Adaptor BOSS PSA-120, 220 or 240
 Rack Mount Adaptor RAD-10
 Footswitch FS-1
 Micro System Rack BMR-5

• Specifications are subject to change without notice.

BOSS Micro Studio Series

RCL-10	Compressor/Limiter
RBF-10	Flanger
RGE-10	Graphic Equalizer
RPH-10	Phaser
RDD-10	Digital Delay

NOTES



Products of Roland

RCL-10 Instructions Printed in Japan '85 Sep. C-3