

BOSS

PH-1 Phaser INSTRUCTIONS

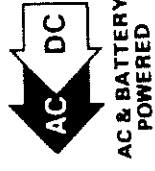

- Please read these instructions carefully for proper operating procedures for the BOSS PH-1.

NAME AND FUNCTIONS

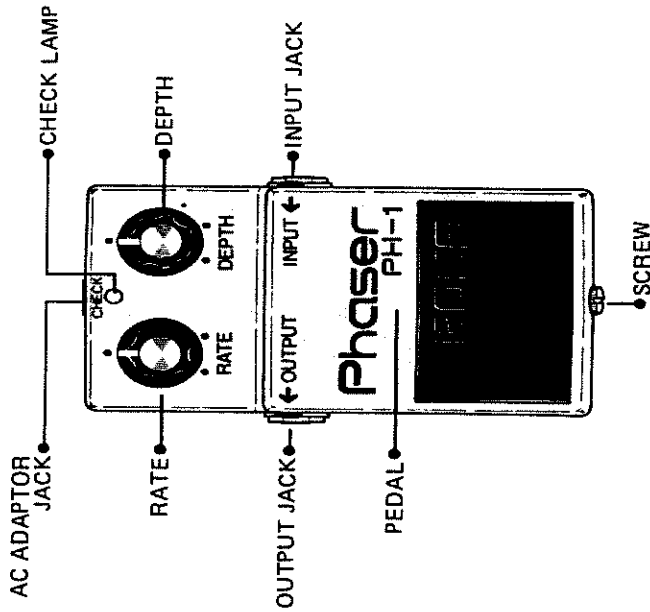

BOSS Phaser PH-1 gives you a sharp phase effect with a wide range from very slow to fast speed. The well-thought-out low-noise construction and natural phase sound will wield an unprecedented power in studio and on stage.

RATE

This knob controls speed of phase effect. At fully clockwise (∩) position, a phase effect of high speed, 100ms, is attained and at fully counterclockwise (∩) position, very low speed, 16s, phase is effected.

DEPTH

This knob controls depth of phase effect. Turn clockwise (∩) for deeper effect and counterclockwise (∩) for shallower effect.

INPUT JACK

This input jack receives output from electric guitar and other electronic instruments.

OUTPUT JACK

This jack feeds signal to amplifier.

AC ADAPTOR JACK

PH-1 operates both from self-contained battery (9V) and from AC line. Connect a BOSS AC Adaptor (DC9V) to this jack, and the battery is disconnected from the circuit, guaranteeing stable long-time performance.

PEDAL SWITCH

This is a changeover switch for Normal or Effect. By use of **FET ELECTRONIC SWITCH**, first in these kinds of small size effect units, pop noise is perfectly eliminated and PH-1 can be satisfactorily employed even in studio recording.

CHECK LAMP

While pedal is trod down, this lamp lights if battery is normal. Thus this lamp lets you confirm the changeover between Effect and Normal modes, and also battery state.

If the indicator fails to light, replace the battery with a new one.

SCREW

When replacing battery, loosen this screw to open the casing. Do not remove off the screw from the pedal. If you do, be careful not to lose it.

BEFORE USING PH-1

- When operating PH-1 from AC line, use BOSS AC Adaptor for PH-1.
- Avoid using PH-1 in very dusty location or under high temperature or humidity conditions.

CONNECTING PH-1

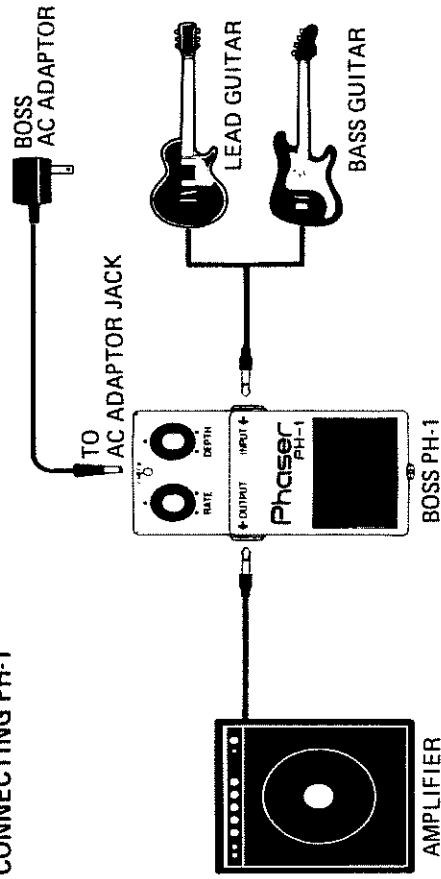

OPERATING PH-1

1

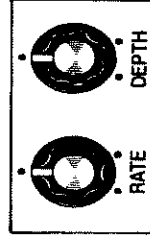

After connecting all cords required, set all knobs on the panel as illustrated.

2

Tread the pedal to check battery. If check lamp lights, battery is live.

* If lamp does not light, which means dead battery, replace with a new battery.

3

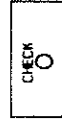

Tread pedal to set the unit in the state that sound is effected.

4

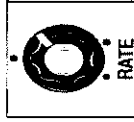

Turn RATE control to proper position.

5

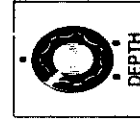

Turn DEPTH control to proper position to obtain the depth you like.

CAUTIONS FOR REPLACING AND HANDLING BATTERY

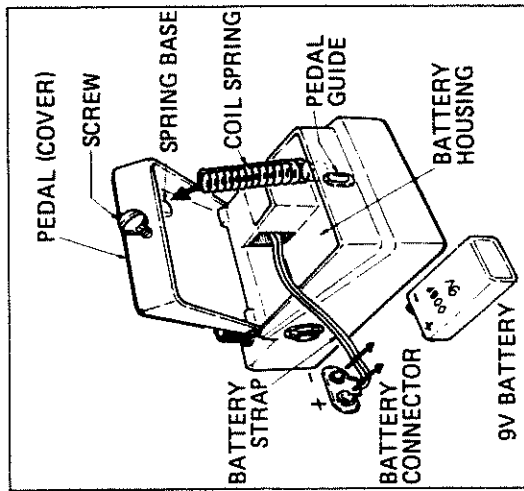

REPLACING BATTERY USE ONE 9-VOLT BATTERY.

- 1 Loosen the screw of pedal to open it and take out battery from its housing.
 - 2 Replace the battery by a fresh one and put it into position.
 - 3 Set coil spring onto the projection on the rear of the pedal and shut the cover (pedal). Finally, insert the screw into the pedal guide and tighten it.
- At this time, be careful not to catch the battery strap in the cover or coil spring.

CAUTIONS

- When you don't use for a long period, remove the battery to prevent current leakage and leaking out of sticky substance.
- If battery voltage drops, effect becomes inferior or no sound is produced. To prevent that, replace the battery a little earlier.
- Be sure to keep the battery snapped by connector into the housing, when using AC adaptor, too.
- Even if AC Adaptor cord comes out during performance, operations immediately changes to battery, causing no trouble in continued performance.
- Power is switched on while a plug is put into input jack. When you do not use, keep the plug off the jack.

AC ADAPTOR (OPTION)

When you operate PH-1 from AC line, use AC adaptor for PH-1.

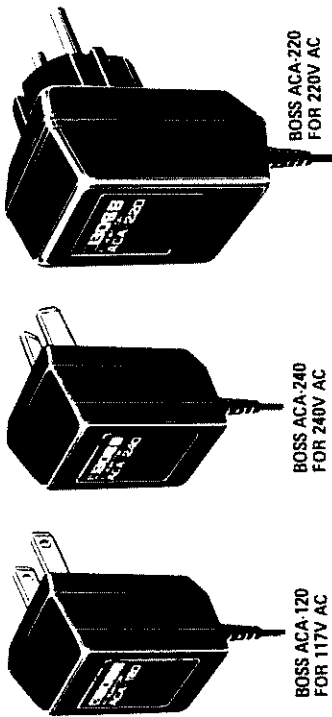

SPECIFICATIONS

Power	Battery 9V (1) AC Adaptor
Current draw	DC9V, 7mA
Control	Rate, Depth
Others	Normal/Effect Changeover Switch, Battery Check Lamp (also for confirmation of Normal/Effect changeover)
Jack	Input, Output, AC Adaptor
Phase shift	4 steps, 720°
LFO Speed	16 sec — 100msec
S/N ratio	Over 80dB
Input impedance	220K Ω
Output load impedance	Over 600 Ω
Maximum input	-20dB
Gain	UNITY 1
Dimensions	70(W) x 55(H) x 125(D)mm
Weight	400g

* Specifications are subject to change without notice.



Printed in Japan, Oct. '77 E-2

 Roland®

10419

UPC

10419



1991

 Roland®