

# PA SYSTEMS

**PA SERIES**

**8 CHANNEL MIXING AMPLIFIER**

**MODEL PA-120 • PA-120S**

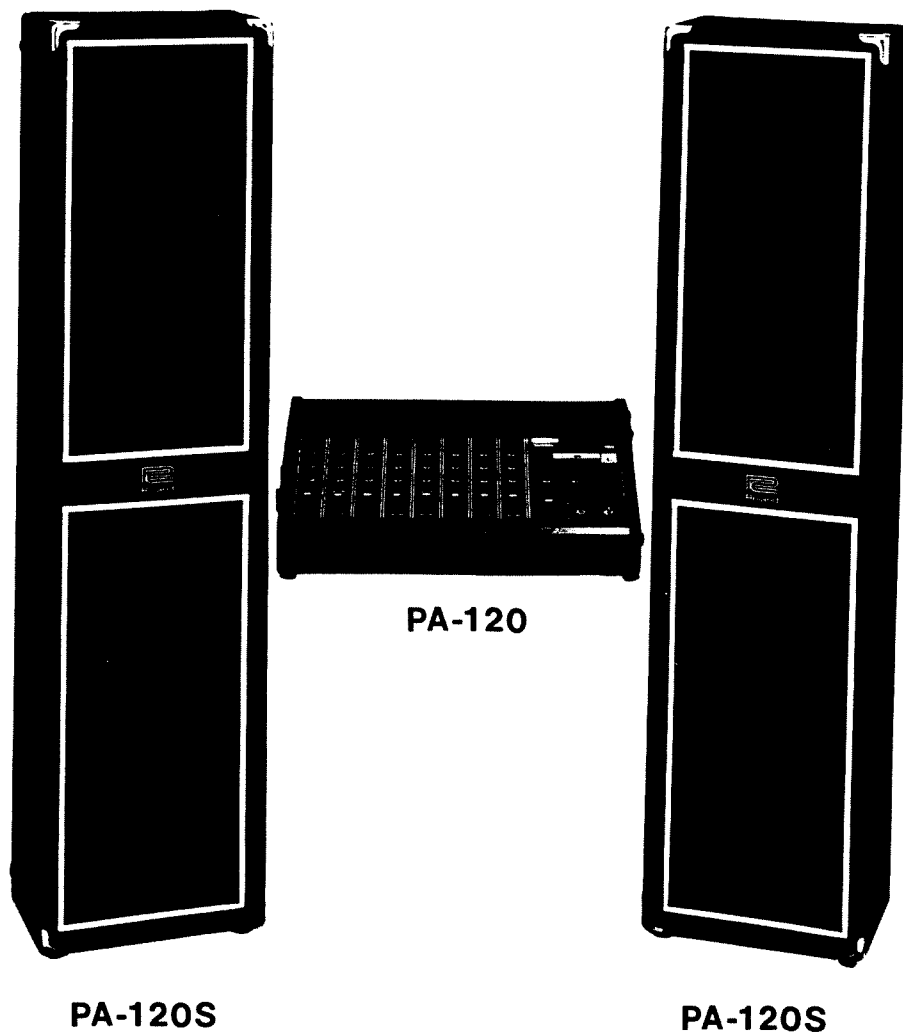

# Roland PA SERIES MODEL PA-120

PA-120 is a professional type 8 channel public-address amp for stage use.

## FEATURES

- The first big capacity desk type PA amp combining a 120W (R.M.S.) main amp in the mixing unit. A 120W power can be easily obtained by connecting conventional speaker cabinet without using a slave amp.
- Mic input and other various input/output terminals are located on the rear panel ensuring easy operation.
- Combination of 2 sets for 16 channel use

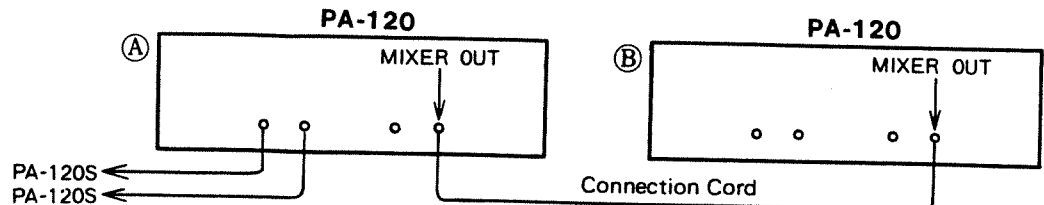

In this case, the main volume of set (B) will not serve as volume adjustor, and the total volume of (A) and (B) can be adjusted by the main volume of the (A).

### ★ Use of second set as a slave amp

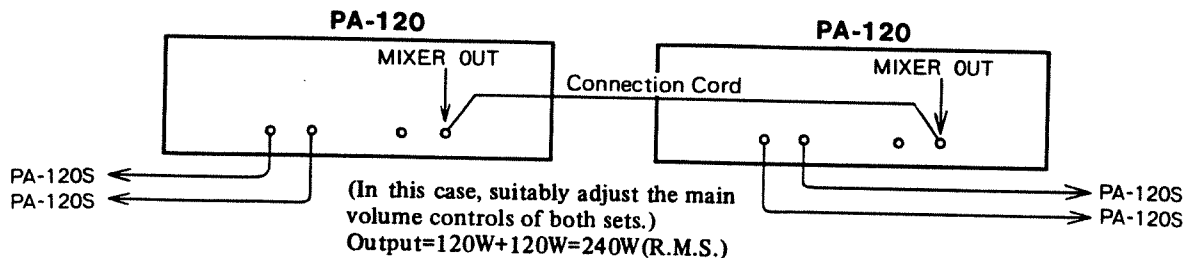

- How to augment power by connecting slave amps

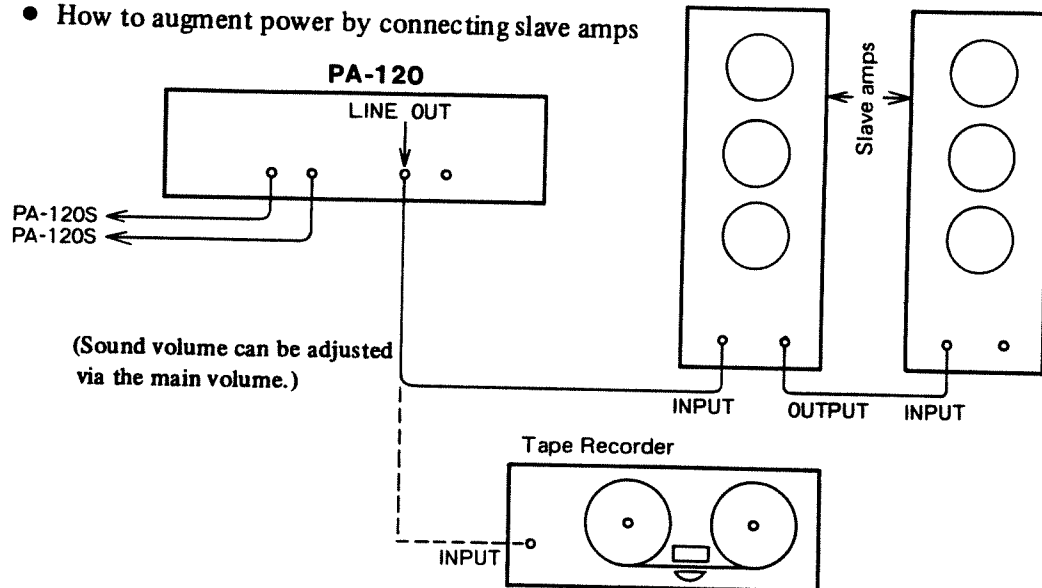

### ★ When recording, connect to the LINE OUT jack.

- Thanks to the employed unique attenuator with click, easy and sure control of the volume for each channel and master is ensured.
- Reverb and echo can be independantly controlled for each channel.
- Due to the employed headphone volume change-over switch (3-step changeover: L/M/H) in the headphone terminal for monitor, wide dynamic range can be obtained.

## PREPARATION

1. Set all knobs to 0 position.
2. Set the stand-by switch to OFF (lower side).
3. Connect the speaker PA-120S to the speaker terminal on the rear panel with a connection cord.
4. Plug the power cord into the mains socket after ensuring the power switch is OFF.
5. For the echo chamber terminal on the rear panel, connect TO ECHO jack to INPUT of the echo chamber, and FROM ECHO jack to OUTPUT, with connection cord.
6. Connect low impedance (200 ~ 600-ohm) microphones to mic terminals (MIC 1 to 8 jacks)

## ADJUSTMENT

1. When the power switch is set to ON, the VU meter lamp lights.
2. Set the main volume to 5-grade position.
3. Set the stand-by switch to ON on the same channel as the jack connected with microphone, then, the channel is operative.
4. Set the volume on each channel to appropriate position. In case many mics are used, adjust the total volume by the main volume, after adjusting volume of each channel.
5. Set the Treble and Bass knobs to appropriate tone.
6. If noise and power supply hum generate, change-over the power switch position up or down to choose better one.
7. It is designed to be no-deviation maximum output (120W R.M.S. – 6 ohm load) when the pointer in the VU meter is in the 0 position. If the pointer deflects to plus (red zone), lower the volume of each channel or main volume.
8. Set the reverb volume to 5-grade position and turn the effect volume of each channel clockwise to deepen the reverberation effect. Adjust the total reverberation effect with the reverb volume.
9. Set the echo volume to 5-grade position and turn the effect volume of each channel clockwise, then echo effect can be obtained.
10. Use the AC OUTLET for the echo chamber, tape recorder, etc.  
Its electricity can be used upto 300W. Note that this socket is operative even when the power switch on the front panel is OFF.

## CAUTION

- When transporting the PA-120, be sure to cover with the vinyl cover attached in order to protect the panel.
- Set the amp volume to OFF when connecting/disconnecting the power plug, microphone and echo chamber plugs, otherwise, speaker may be damaged.
- Since the PA-120 comprises of precision component parts, be sure not to shock to the amp.

# PA-120 GENERAL SCHEMATIC DIAGRAM

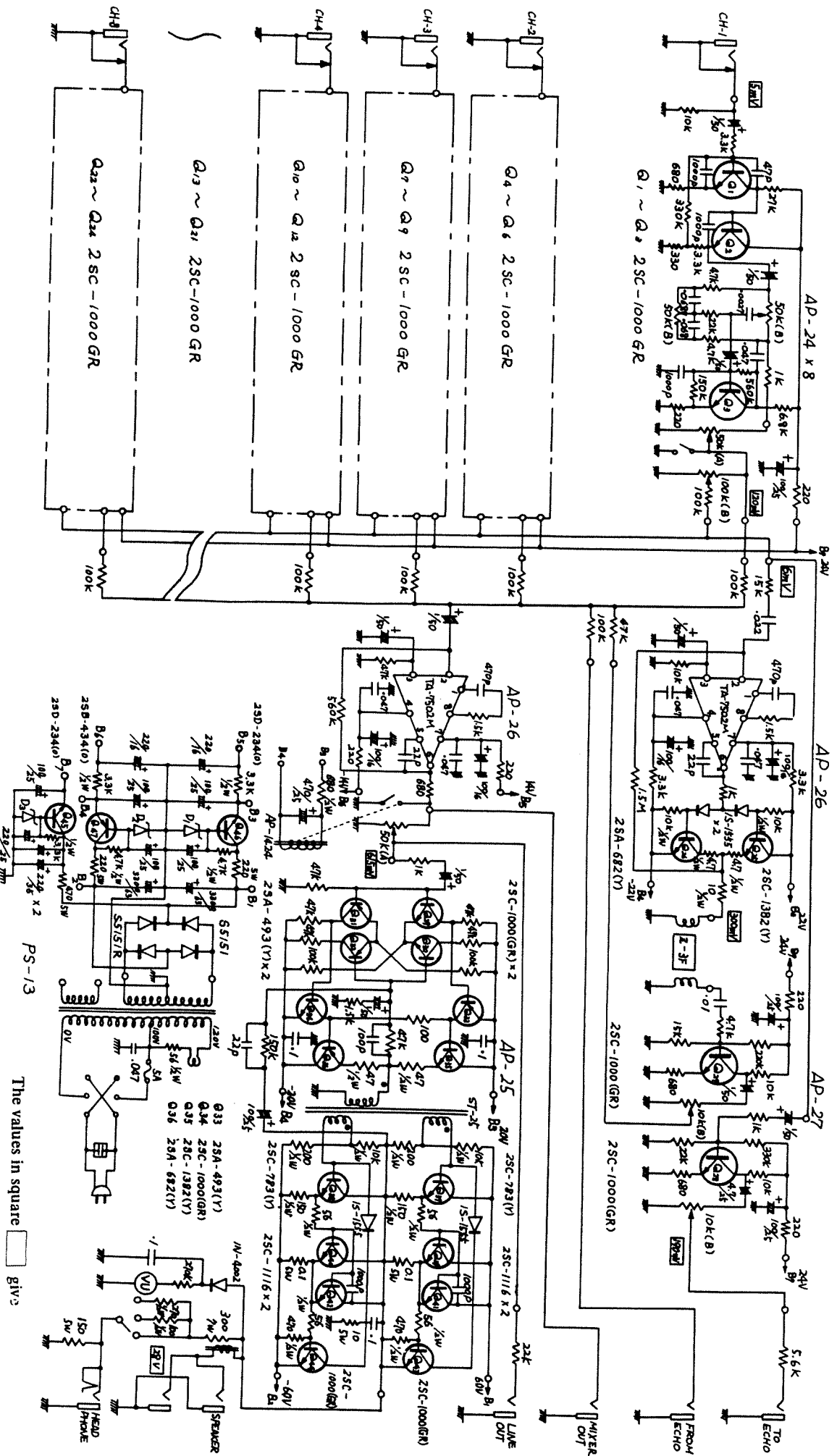

These circuits are subject to change without notice.

# PA-120 PANEL DISTRIBUTION

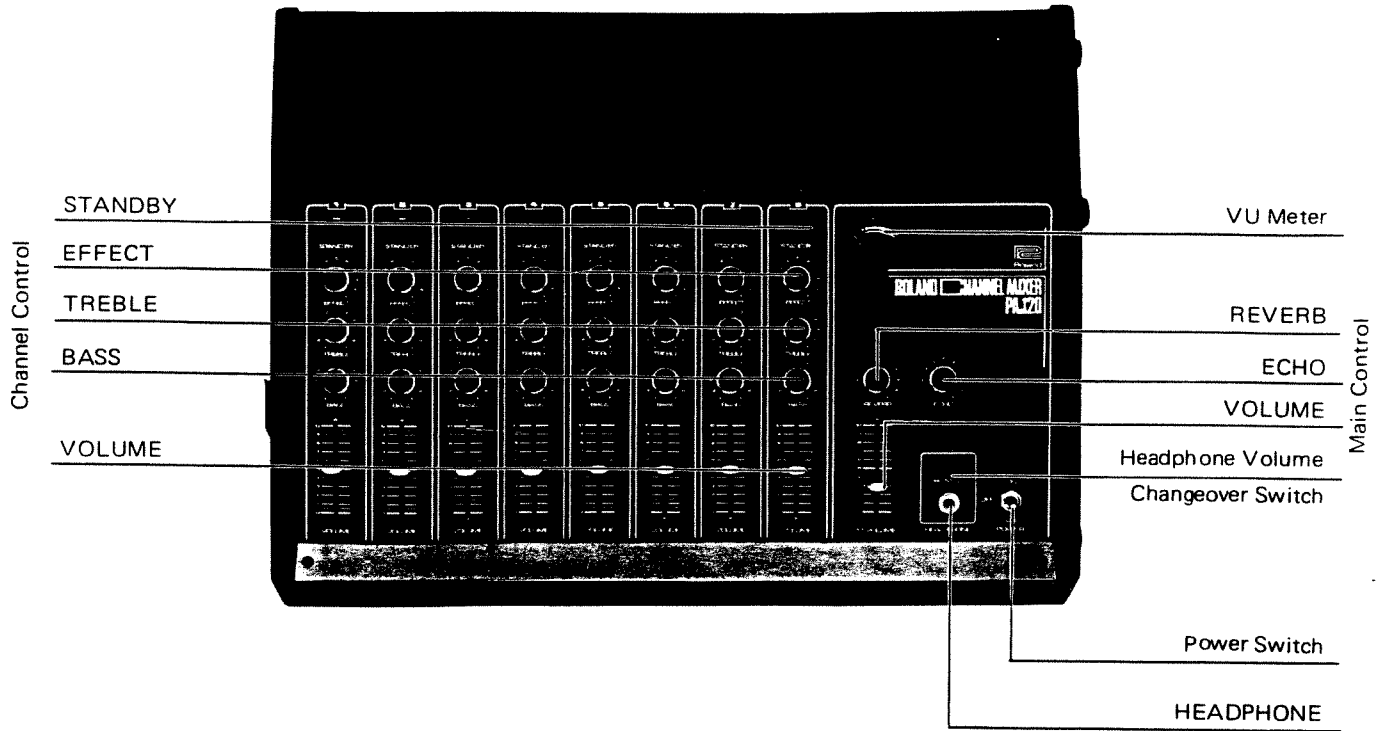

## \* Connection of Mic, Guitar and Echo Chamber.

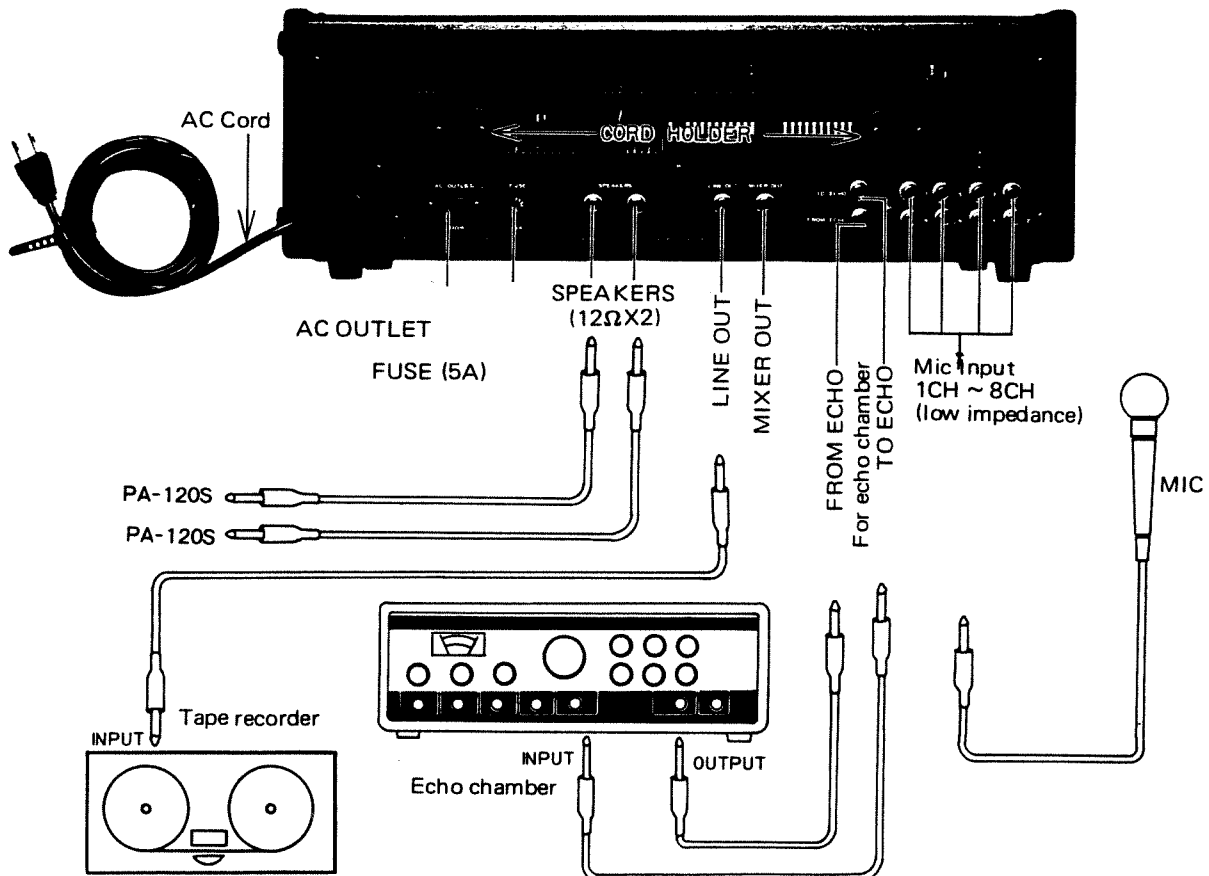

# Roland PA SERIES

## MODEL PA-120 · PA-120S

### SPECIFICATIONS

Inputs (8-channel system)	Mic Channel (low impedance) . . . . .	8
Channel Control	Volume . . . . .	8
	Effect . . . . .	8
	Bass . . . . .	8
	Treble . . . . .	8
	Standby . . . . .	8
	Main Control	Main Volume . . . . .
Echo Volume . . . . .		1
Reverb Volume . . . . .		1
Headphone (with volume changeover switch: 3-step changeover L/M/H) . . . . .		1
Power Switch . . . . .		1
Output Jacks	Speakers (12Ω – 8Ω: parallel) . . . . .	2
	Headphone . . . . .	1
	Line out . . . . .	1
	Mixer out . . . . .	1
	R.M.S.	120W (6Ω load)
Peak Power	240W (6Ω load)	
Others	AC Outlet . . . . .	1
	Jacks for Echo Chamber . . . . .	2
	VU meter . . . . .	1
	Semiconductors	Transistors . . . . .
	Diodes . . . . .	10
	I.C. . . . .	2
AC Voltage	100V, 117V, 220V, 250V, 50/60Hz	
Power Consumption	600 VA	
Speaker Systems	PA-120S (20cmSP x 6: impedance 12Ω: Input 100W R.M.S.) x 2	
Dimensions	PA-120: 551(W) x 390(D) x 170/78(H)mm	
	PA-120S: 340(W) x 250(D) x 1415(H)mm	
Weight	PA-120: 17 Kgs	
	PA-120S: 22 Kgs x 2	
Accessory	Cover . . . . .	1

SPECIFICATIONS SUBJECT TO CHANGE WITHOUT NOTICE



 Roland®

---

**10199**

UPC

10199



10981

 Roland®