

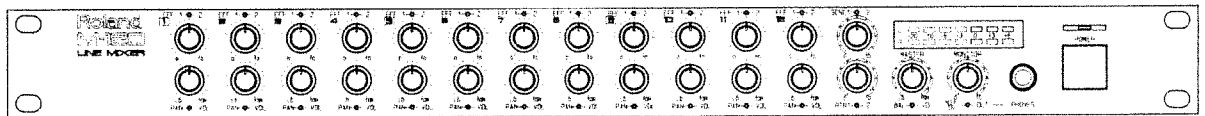

Roland

LINE MIXER

M-120

OWNER'S MANUAL



	CAUTION RISK OF ELECTRIC SHOCK DO NOT OPEN	
ATTENTION : RISQUE DE CHOC ELECTRIQUE NE PAS OUVRIR		
<p>CAUTION: TO REDUCE THE RISK OF ELECTRIC SHOCK. DO NOT REMOVE COVER (OR BACK). NO USER-SERVICEABLE PARTS INSIDE. REFER SERVICING TO QUALIFIED SERVICE PERSONNEL.</p>		



The lightning flash with arrowhead symbol, within an equilateral triangle, is intended to alert the user to the presence of un-insulated "dangerous voltage" within the product's enclosure that may be of sufficient magnitude to constitute a risk of electric shock to persons



The exclamation point within an equilateral triangle is intended to alert the user to the presence of important operating and maintenance (servicing) instructions in the literature accompanying the product.

INSTRUCTIONS PERTAINING TO A RISK OF FIRE, ELECTRIC SHOCK, OR INJURY TO PERSONS.

IMPORTANT SAFETY INSTRUCTIONS

WARNING — When using electric products, basic precautions should always be followed, including the following:

1. Read all the instructions before using the product.
2. Do not use this product near water — for example, near a bathtub, washbowl, kitchen sink, in a wet basement, or near a swimming pool, or the like.
3. This product should be used only with a cart or stand that is recommended by the manufacturer.
4. This product, either alone or in combination with an amplifier and headphones or speakers, may be capable of producing sound levels that could cause permanent hearing loss. Do not operate for a long period of time at a high volume level or at a level that is uncomfortable. If you experience any hearing loss or ringing in the ears, you should consult an audiologist.
5. The product should be located so that its location or position does not interfere with its proper ventilation.
6. The product should be located away from heat sources such as radiators, heat registers, or other products that produce heat.
7. The product should avoid using in where it may be effected by dust.
8. The product should be connected to a power supply only of the type described in the operating instructions or as marked on the product.
9. The power-supply cord of the product should be unplugged from the outlet when left unused for a long period of time.
10. Do not tread on the power-supply cord.
11. Do not pull the cord but hold the plug when unplugging.
12. When setting up with any other instruments, the procedure should be followed in accordance with instruction manual.
13. Care should be taken so that objects do not fall and liquids are not spilled into the enclosure through openings.
14. The product should be serviced by qualified service personnel when:
 - A. The power-supply cord or the plug has been damaged; or
 - B. Objects have fallen, or liquid has been spilled into the product; or
 - C. The product has been exposed to rain; or
 - D. The product does not appear to operate normally or exhibits a marked change in performance; or
 - E. The product has been dropped, or the enclosure damaged.
15. Do not attempt to service the product beyond that described in the user-maintenance instructions. All other servicing should be referred to qualified service personnel.

SAVE THESE INSTRUCTIONS

WARNING: THIS APPARATUS MUST BE EARTHED

For the U.K.

IMPORTANT: THE WIRES IN THIS MAINS LEAD ARE COLOURED IN ACCORDANCE WITH THE FOLLOWING CODE.
GREEN-AND-YELLOW: EARTH, BLUE: NEUTRAL, BROWN: LIVE

As the colours of the wires in the mains lead of this apparatus may not correspond with the coloured markings identifying the terminals in your plug proceed as follows:

The wire which is coloured GREEN-AND-YELLOW must be connected to the terminal in the plug which is marked by the letter E or by the safety earth symbol  or coloured GREEN or GREEN-AND-YELLOW.

The wire which is coloured BLUE must be connected to the terminal which is marked with the letter N or coloured BLACK.

The wire which is coloured BROWN must be connected to the terminal which is marked with the letter L or coloured RED.

The product which is equipped with a THREE WIRE GROUNDING TYPE AC PLUG must be grounded.

Thank you, and congratulations on your choice of a Roland product. The M-120, though compact enough that it takes only one unit of rack space, is a multi-function 12-channel line mixer able to provide the utmost in performance at a very favorable cost/performance ratio.

In order to get the most out of this unit for many years to come, first take the time to read this manual in full.

FEATURES

- Packs a 12-channel mixer, equipped with two independent Effects Send/Return loops, into a unit taking only 1U of rack space.
- Clean mixing is assured thanks to the extremely low-noise design, which has already won acclaim for the M series.
- As a result of engineering dedicated to the quality of sound, the M-120 is able to produce results that rival that of professional high-end equipment.
- For output, it is provided not only with standard 1/4" phone jacks, but with XLR connectors as well. This enables you to use the unit as a sub-mixer when connected with professional-use equipment.
- In addition to Master Out it is also equipped with an independent Monitor Out. You thus have separate, independent control over both the volume of sound monitored on stage, and that sent to the console.
- Equipped with a Monitor Mix In, useful such as when wishing to monitor a sequencer's click, either from Monitor Out, or with headphones.
- Settings for level are facilitated by an easy-to-read, seven-segment LED level meter.

IMPORTANT NOTES

[Concerning the power supply]

- Whenever you make any connections with other devices, always turn off the power to all equipment first. This will help in preventing malfunction, and damage to speakers.
- Do not force the unit to share the same power outlet as one used for distortion producing devices (such as motors, variable lighting devices). Be sure to use a separate power outlet.
- Do not place heavy objects onto, step on, or otherwise risk causing damage to the power cord.

[Concerning placement]

- Avoid using or storing the unit in the following places, as damage could result.
 - Places subject to extremes in temperature. (Such as under direct sunlight, near heating units, above equipment generating heat, etc.)
 - Places near water and moisture. (Baths, washrooms, wet floors, etc.) Places otherwise subject to high humidity.

- Dusty environments.
- Places where high levels of vibration are produced.

- Placing the unit near power amplifiers or other equipment containing large transformers may induce hum.

[Maintenance]

- For everyday cleaning, wipe the unit with a soft dry cloth, or one that is dampened slightly. To remove dirt that is more stubborn, wipe using a mild, neutral detergent. Afterwards, make sure to wipe thoroughly with a soft cloth.
- Never apply benzene, thinners, alcohol or any like agents, to avoid the risk of discoloration and deformation.

[Other Precautions]

- Protect the unit from strong impact.
- Avoid getting any foreign objects (coins, wire, etc.), or liquids (water, drinks, etc.) into the unit.
- Never apply strong pressure to the display, or strike it in any way.
- A certain small amount of heat will be radiated from the unit, and thus should not be considered abnormal.
- Before using the unit in a foreign country, check first with your local Roland Service Station.
- At any time that you notice a malfunction, or otherwise suspect there is damage, immediately refrain from using the unit. Then contact the store where bought, or the nearest Roland Service Station.

CONTENTS

1	Block Diagram and Signal Flow	5
1.	Channel Section	5
2.	Master Section	5
a.	Master Out	5
b.	Effect Send	5
c.	Return	5
d.	Monitor Mix In	5
e.	Monitor Out	5
2	Panel Descriptions	6
1.	Front Panel	6
2.	Rear Panel	7
3	Setup and Operation	8
■	Starting Up	8
1.	Basic setup for using electronic instruments	8
■	Mixing using electronic musical instruments	8
2.	Setup using effects devices	9
■	Effects processing using delay, reverb, etc.	9
3.	Connections for monitoring	10
■	Monitoring and mixing	10
4	Input/Output Standards	11
5	Specifications	12

1 Block Diagram and Signal Flow

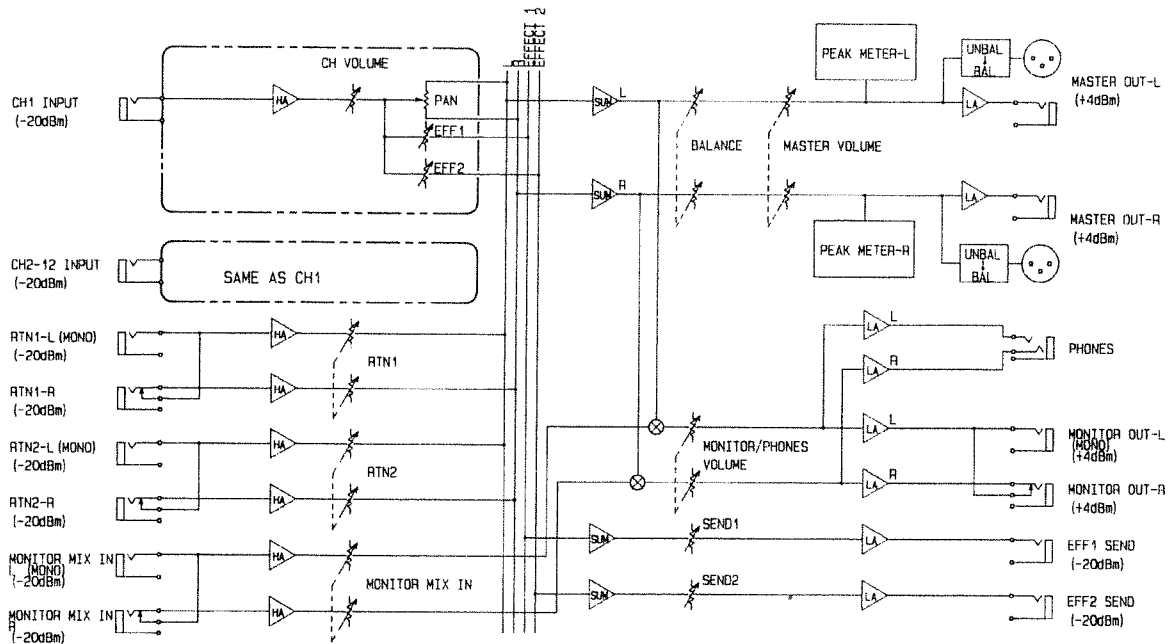

1. Channel Section

The signals arriving at the input jacks pass through the head amp, and adjustment of channel volume is made. After leaving channel volume, the signals are divided into L and R by the panpots, then sent to the Master Section. A portion of the signals, after passing through channel volume (post fader), is split off, and after passing through Effect Volume, is sent to the Master Section.

2. Master Section

a. Master Out

The signals from each channel and from return are mixed. Then after the final adjustment of level is made by Master Volume, they are sent to Master Out.

b. Effect Send

Mixing of all signals coming from the Effect Volume of each channel is performed. Then after the level is adjusted at Effect Send Volume, they are sent to Effect Send.

c. Return

The signals input at Return go to the head amp. Then after passing through Return Volume they are mixed and sent to both Master Out and Monitor Out.

d. Monitor Mix In

The signals arriving at Monitor Mix In pass through the head amp, then are adjusted at Monitor Mix In Volume. The master signals (signals prior to Master Volume) along with those after the mix are sent to Monitor Out.

e. Monitor Out

The signals from each channel and from Return, along with those from Monitor Mix In have their level adjusted at Monitor Out Volume, then are sent to Monitor Out.

2 Panel Descriptions

1. Front Panel

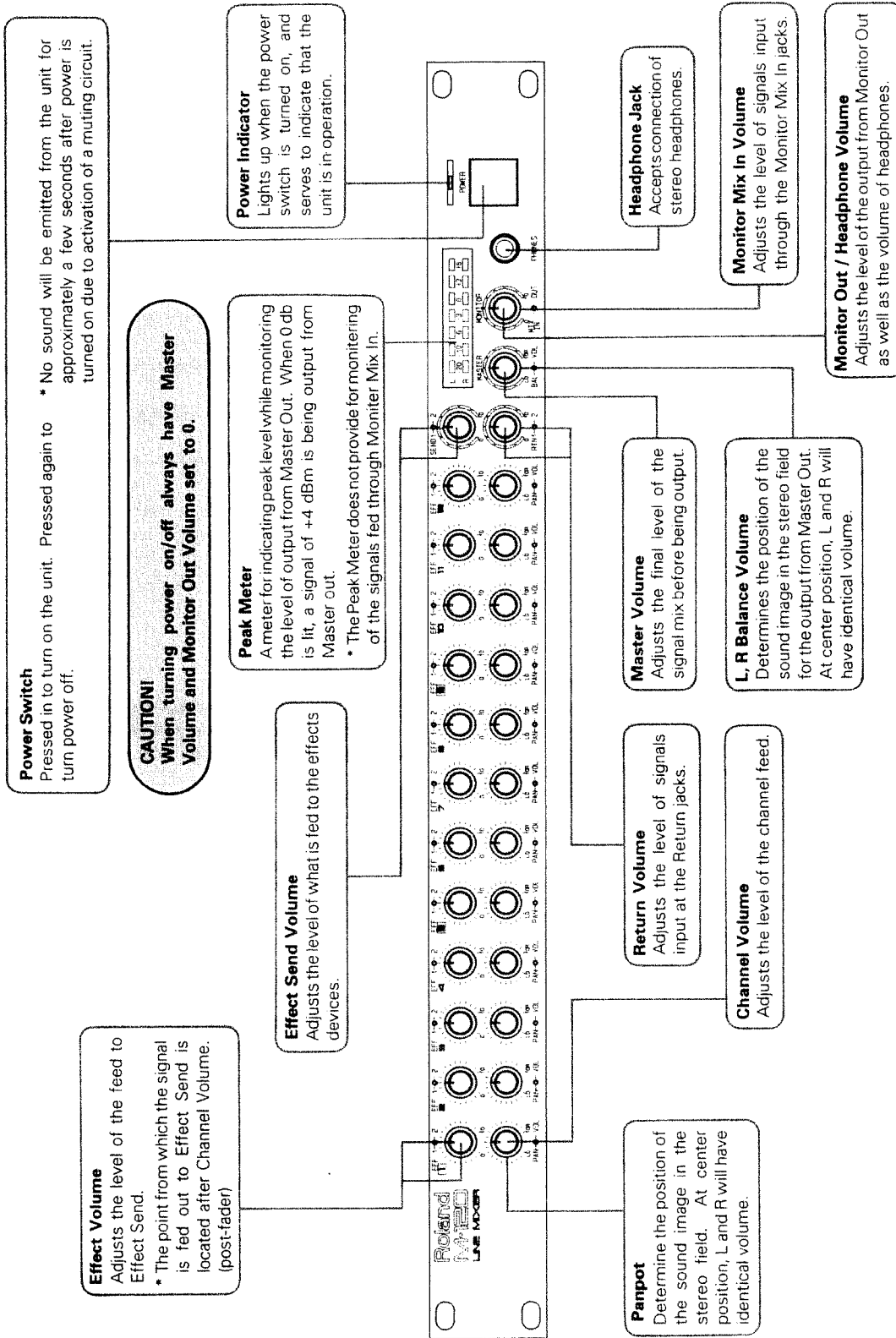

2. Rear Panel

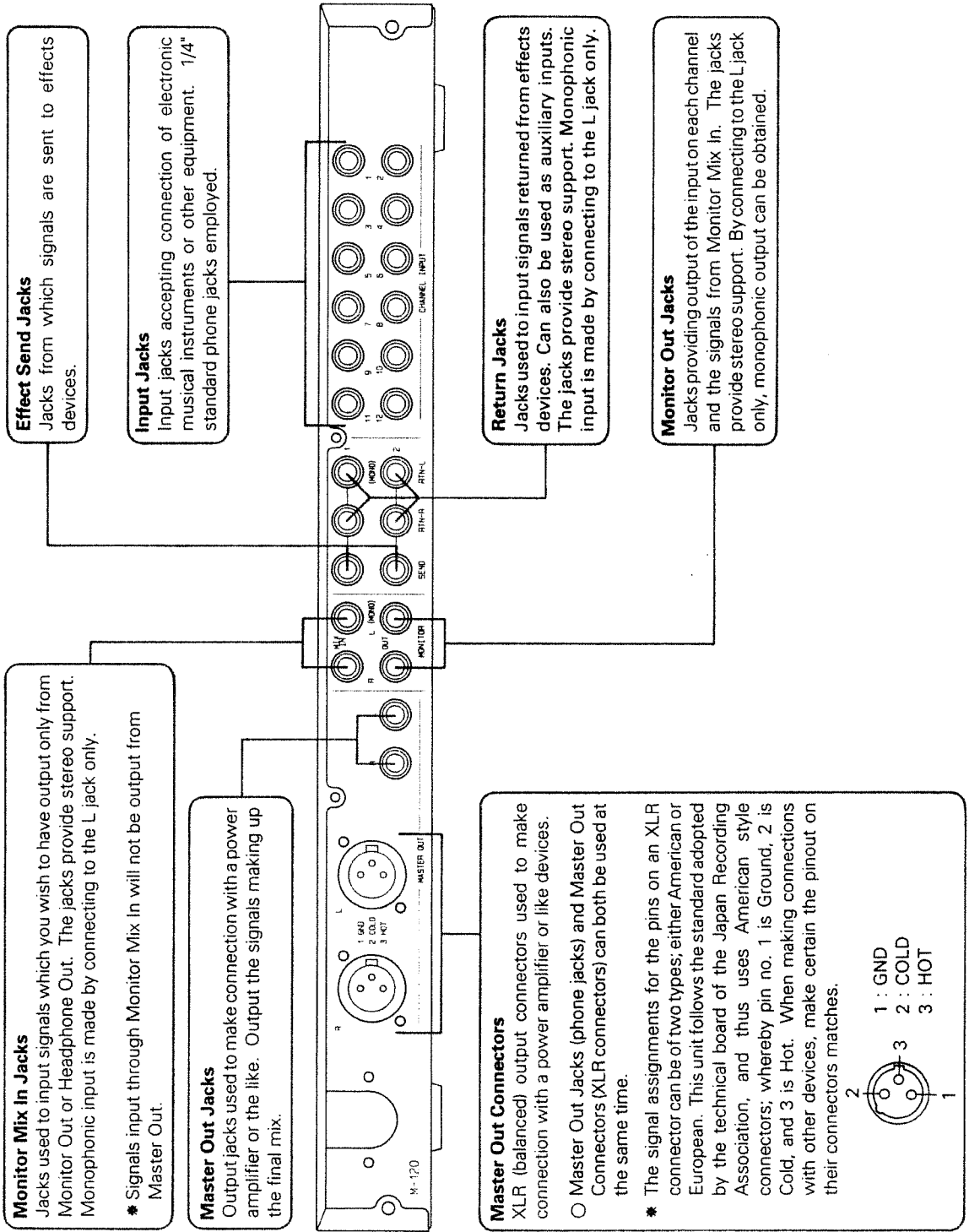

3 Setup and Operation

■ Starting Up

- ① Check that the power switch is off, then insert the plug on the power cord into an outlet.
- ② Connect up all equipment that is going to be used. (Refer to illustrated setup example.)
- ③ Set the volume on all devices to 0.
- ④ After checking that all connections have been made properly, turn power on for any equipment being used for input. Then, turn on power to the M-120. Last, turn on the power amplifier's power switch. (Perform the above in reverse order when turning off power.)

1. Basic setup for using electronic instruments

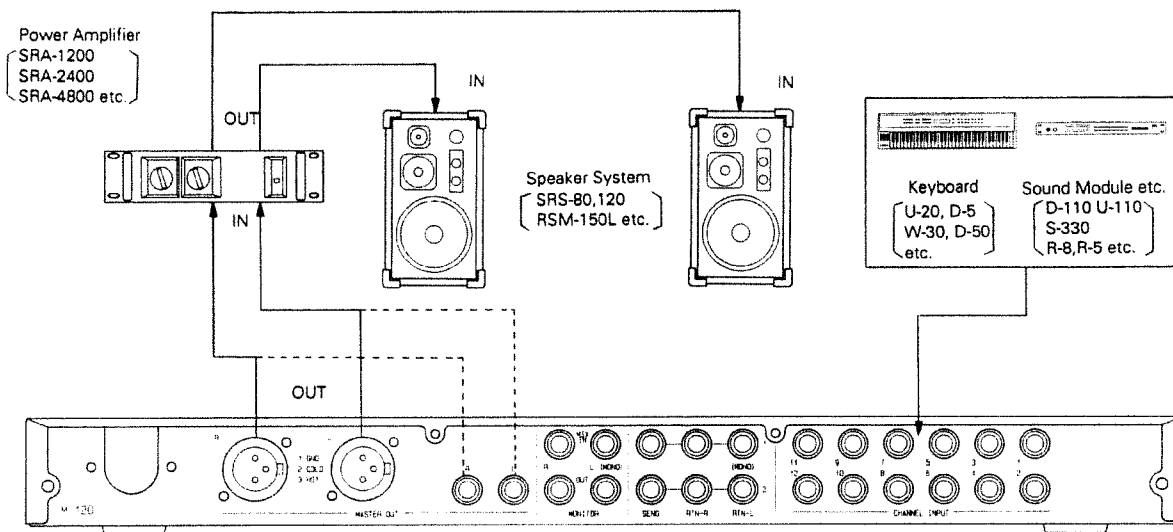

■ Mixing using electronic musical instruments

- ① Play the instrument with Master Volume raised a little. The volume balance for each channel is adjusted using Channel Volume.
- * If you start out with the Channel Volume raised to around 7, then adjust volume by adjusting the output coming from the instrument, mixing can be performed more easily.

Notice!

The unit's input level is rated at -20 dBm. Excessive input can cause sound distortion. To avoid this problem, lower the volume being output from the instrument.

- ② Set the positioning of the sound image, in respect to L & R, using the Panpots.
 - ③ Finally, adjust the overall volume level using Master Volume.
- * When employing headphones during mixing, adjust Headphone (Monitor Out) Volume to your liking.

2. Setup using effects devices

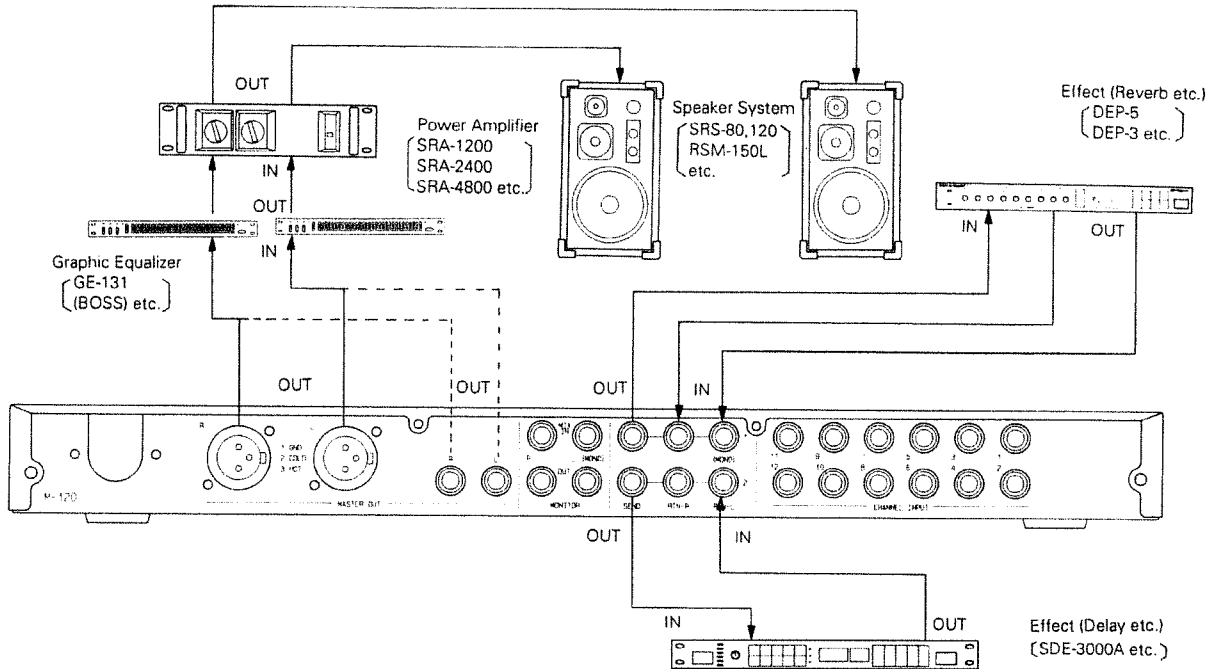

■ Effects processing using delay, reverb, etc.

- ① Make suitable adjustment of the Effect Volume for the channel to which you wish to apply effects. Then, while viewing the input level meter, etc., for the effects devices, adjust the overall level to be output using the Master Section's Effect Send Volume.
 - ② Adjust the level of the sound being returned from the effects using Return Volume.
- * The direct sound is processed within the mixer, so return only the effect sound.
 - * The point from which the signals for Effect Send are fed out occurs after the signals have passed through Channel Volume. (post-fader)
 - * If you connect a graphic or parametric equalizer between the mixer and power amplifier, you will then be able to make corrections in the sound field and overall quality of the sound.

4 Input/Output Standards

■ Input Standard

Input Socket		Input Sensitivity	Rated Input Level	Input Impedance	Recommended Source Impedance	Type of Connectors
CHANNEL INPUT	CH1~12 (PHONE-UNBAL)	-26 dBm (38.8 mV)	-20 dBm (77.5 mV)	20 k Ω	Less than 2 k Ω	PHONE
RETURN	1.(L,R) 2.(L,R)	-26 dBm (38.8 mV)	-20 dBm (77.5 mV)	20 k Ω	Less than 2 k Ω	PHONE
MONITOR MIX IN	L,R	-26 dBm (38.8 mV)	-20 dBm (77.5 mV)	10 k Ω	Less than 1 k Ω	PHONE

■ Output Standard

Output Socket		Rated Output Level	Non-Clip Max. Output	Output Impedance	Recommended Load Impedance	Type of Connectors
MASTER OUT	BALANCED	+4 dBm ^{*1} (1.23 V)	+20 dBm ^{*1} (7.75 V)	600 Ω	More than 600 Ω	XLR-3-32 (XLR Connector)
	UNBALANCED	+4 dBm (1.23 V)	+20 dBm [*] (7.75 V)	300 Ω	More than 3 k Ω	PHONE
SEND	1,2	-20 dBm (77.5 mV)	-4 dBm (489 mV)	330 Ω	More than 3 k Ω	PHONE
MONITOR OUT		+4 dBm (1.23 V)	+20 dBm (7.75 V)	3.3 k Ω	More than 6 k Ω	PHONE
PHONES		—————	70 mW+70 mW ^{*2}	100 Ω	More than 8 Ω	STEREO PHONE

@ : 0 dBm=0.775 Vrms

*1 : 600 Ω Loaded

*2 : Both Channels 100 Ω Loaded

5 Specifications

Frequency Response:	20 Hz - 20 kHz (± 1 dB)
Total Harmonic Distortion:	0.05% or less (20 Hz - 20 kHz rated output)
Noise Level	(Input Shorted, IHF-A, Typ.)
Equivalent Input Noise:	-123 dBm
Residual Noise:	-103 dBm [All Volume: min.]
	-85 dBm [Master Volume: max.]
	[All Channel Volume: min.]
	-79 dBm [Master Volume: max.]
	[All Channel Volume: max.]
Crosstalk:	-70 dB or less (1 kHz between channels)
	-60 dB or less (1 kHz between L and R)
Power:	AC 117V/220V/240V (50/60Hz)
Power Consumption:	16 W
Dimensions:	482 (W) x 281 (D) x 44 (H) mm
	19 (W) x 11-1/16" (D) x 1-3/4" (H)
Weight:	3.9 kg / 8 lb 10 oz

* Specifications are subject to change without notice.

 Roland®

26035311

UPC

28035311



10981

Roland