 **BOSS**

Km-60

Mixer

INSTRUCTIONS

• Please read these instructions carefully for proper operating procedures for the BOSS KM-60.

Km-60

Mixer

KM-60 is a universal multi-channel mixer provided with 6-channel inputs, multiple effects jacks, and dual outputs.

By virtue of effect level control for each channel and effect master volume, various kinds of effects units can be connected, to each channel separately or to mixed outputs, as you like.

Two units of KM-60 can be linked very easily through stacking jacks, making up a mightier 12-channel mixer.

The incorporated low-cut filter helps prevent howling in low range through microphone.

Monitoring through stereo headphones jack, you can control the balance of each inputs efficiently.

The side angle allows KM-60 to be mounted on 19-inch width rack and also the unit can be used in an inclined posture simply by changing the positions of the screws.

KM-60 SPECIFICATIONS

| | | LEVEL | IMPEDANCE | NO. |
|---------|--------------------|---------------|-------------------|------|
| CHANNEL | INPUT | -50/-35/-20dB | L: 3.9kΩ; H: 33kΩ | 6 |
| | EFFECTS | SEND | 0dB | 300Ω |
| | | RETURN | -10dB | 10kΩ |
| MIXED | EFFECTS | SEND | 0dB | 300Ω |
| | | RETURN | -26dB | 20kΩ |
| | STACKING | 0dB | 3kΩ | 2 |
| | STEREO MONITOR OUT | - | 8Ω | 1 |
| | OUTPUT | +4dB(0VU) | 300Ω | 2 |

Power consumption 7W
 S/N ratio Over 64dB
 Semiconductors 16 IC's, 16 transistors, 8 diodes
 Dimensions 480(W) x 95(H) x 273(D) mm
 18.9(W) x 3.7(H) x 10.8(D) in
 Weight 4.7kg, 10.4lbs.

* Specifications are subject to change without notice.

CAUTIONS

- Do not put KM-60 or instrument right next to neon or fluorescent lamp. Separate them each other.
- When connecting instrument to KM-60, connect cord plug to source first and then the other end to KM-60. For disconnection, reverse the order: from KM-60 first and then from source.
- Avoid using KM-60 where there is much dust or under high temperature or humidity conditions.
- If your unit is soiled, clean with neutral cleanser.
* Avoid using thinner or the like.
- KM-60 operates on AC mains. It may heat up slightly, but that is not a sign of trouble.

BLOCK DIAGRAM

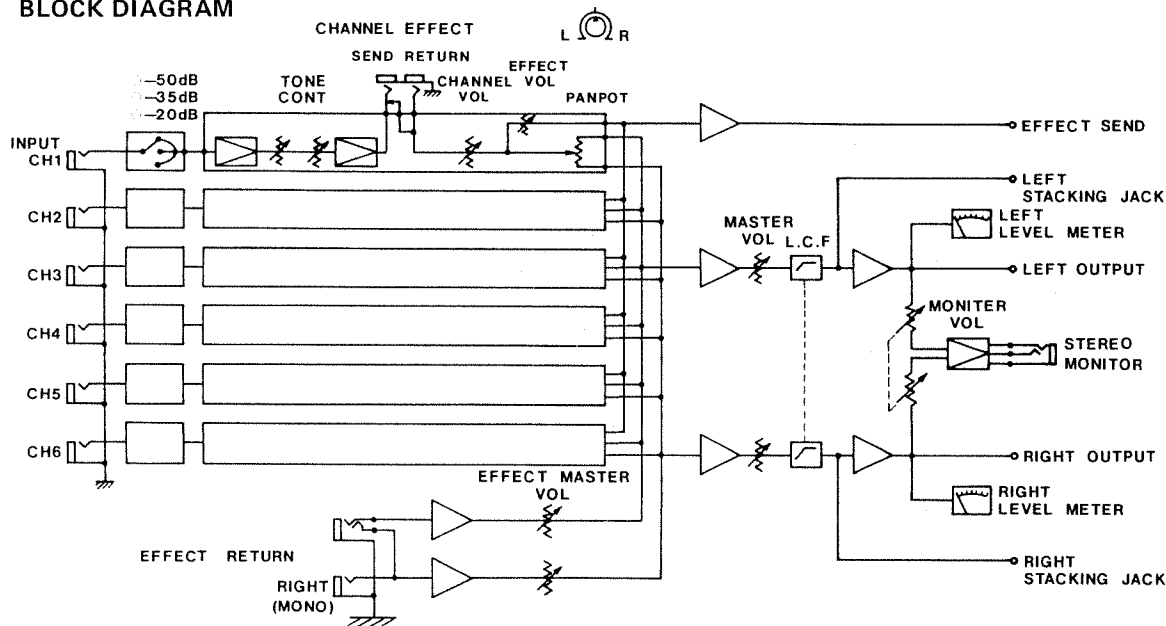

NAME AND FUNCTIONS

REAR PANEL

STACKING OUTPUT: By linking up to another mixer, channels can be expanded. WHEN linking two KM-60's, connect STACKING JACK of one KM-60 to STACKING JACK or EFFECTS RETURN of the other KM-60. (See connection diagram "D".)

WHEN connecting to different model mixer, connect to a suitable input.

OUTPUT JACK: Mixed sounds are sent to independent right and left amplifiers, echo chamber, etc. through these jacks.

STEREO MONITOR JACK: When monitoring with headphones, connect stereo headphones to this jack (impedance: 4-16Ω.)

EFFECTS SEND (MONAURAL OUTPUT): Mixed signal is sent to Echo Chamber, Mixing Amplifier, etc. through this jack.

EFFECTS RETURN: Output from external effects unit is connected to these jacks. When dual outputs are available, connect to R and L jacks and when the output is monaural, connect to R jack. Also used for stacking input. See connection diagram.

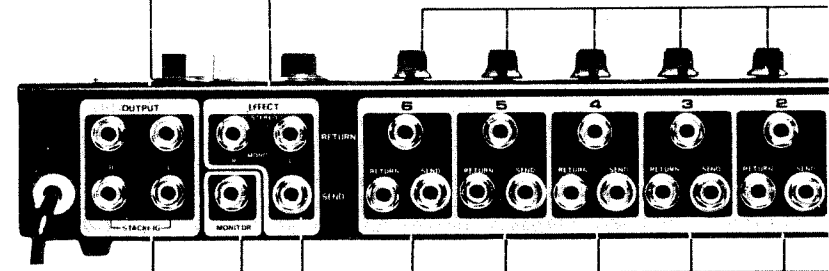

CONTROL PANEL

INPUT ATTENUATOR attenuates input signal to three steps (-50/-35/-20dB) to accurately match KM-60 to any source. Set to -50dB for microphone, -35dB for guitar, and -20dB for synthesizer.

TONE CONTROLS adjust the levels of treble and bass. Normal tone with knob at "5" graduation, and turn knob clockwise (○) to intensify treble or bass, and counterclockwise (○) to de-emphasize.

PANPOT routes each input source from left to right or any point in between to the mixed outputs. When PANPOT of an input channel is set to CENTER, the corresponding input is sent both to right and left outputs equally. When PANPOT is turned clockwise (○), the sound of the input channel shifts to the right. When it is turned counterclockwise (○), the sound shifts to the left.

EFFECTS LEVEL controls level of EFFECTS SEND output (monaural output) of each channel. Turn clockwise (○) to increase and counterclockwise (○) to decrease.

CHANNEL VOLUME controls the level of each input channel. Turn the knob clockwise (○) to increase, and counterclockwise (○) to decrease.

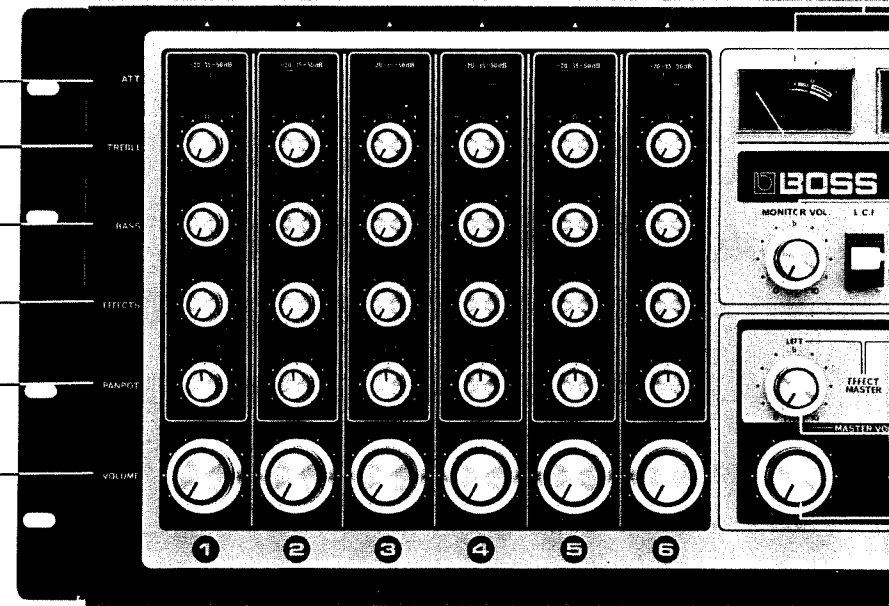

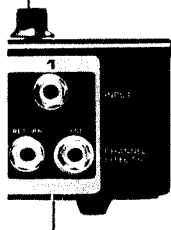

INPUT JACK accepts devices: microphone and instrument for mixing.

CHANNEL EFFECTS: Effects units like Graphic Equalizer GE-6, Delay Machine DM-1, etc. can be connected to each channel selectively through these jacks.

SEND: Output jack to effects unit, etc.

RETURN: Input jack to accepts processed signal from effects unit, etc.

* See connection diagram.

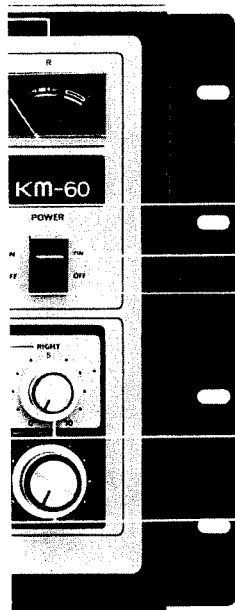

MONITOR VOLUME CONTROL: Monitoring (headphones) volume is adjusted by this knob. Turn clockwise (○) to increase and counterclockwise (○), to decrease.

POWER SWITCH

LOW-CUT FILTER (LCF): With this switch on, proximity effect, wind sound, or rumbling noise that can occur when using microphone can be cut off. (Lower than 300Hz sounds are attenuated at -4dB/octave.)

MASTER VOLUME controls the output level of right and left channels separately. The right-hand knob is for RIGHT OUTPUT and the left-hand knob is for LEFT OUTPUT.

LEVEL METER is stereo level meters indicating the levels of each output. If the meter pointer goes into the plus range (red section), the sound may be distorted.

* At 0-point, the output level is -5dB.

EFFECTS MASTER VOLUME controls overall effects return input level for right and left channels separately. The right-hand knob is for RIGHT EFFECTS RETURN and the left-hand knob is for LEFT EFFECTS RETURN.

HIGH OPERABILITY WITH INCLINED INSTALLATION

KM-60 is provided with side angles on both sides of the body, to make it possible to mount in any EIA width rack. Furthermore simply by changing the position of two screws, each on the right and left sides, the unit can be used in an inclined posture to enhance the operability.

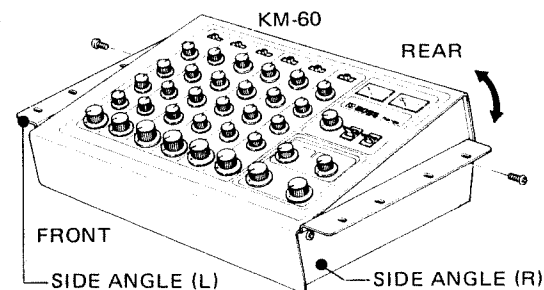

CONNECTING KM-60

A. GENERAL STEREOPHONIC CONNECTION

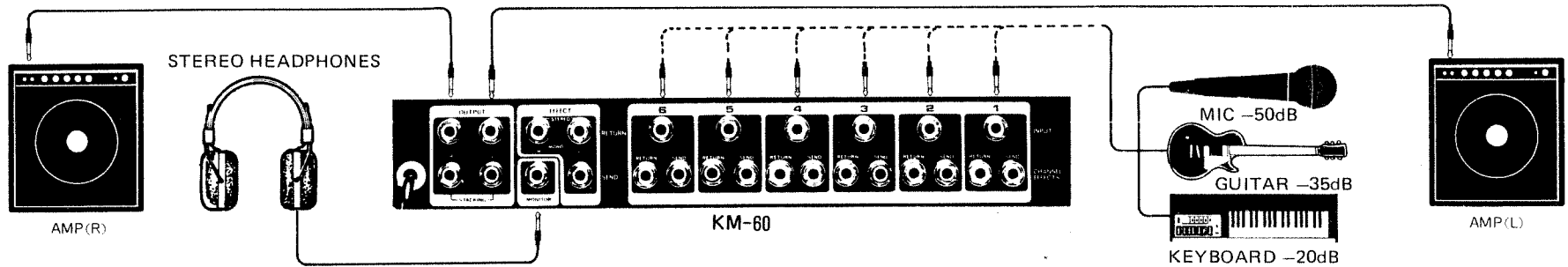

B. USING ECHO CHAMBER FOR MULTI-INSTRUMENT SET-UPS

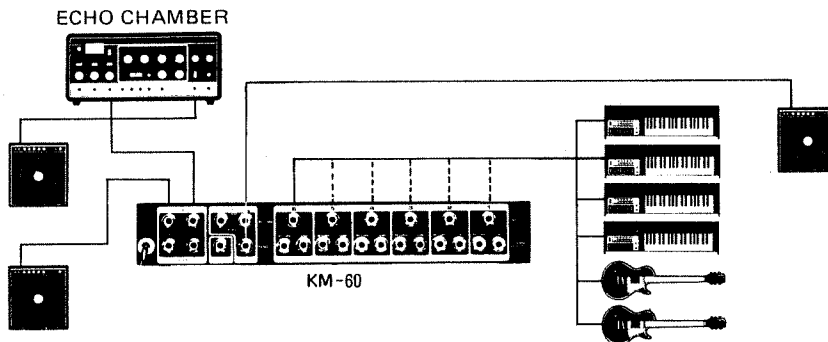

C. USING EFFECTS UNIT

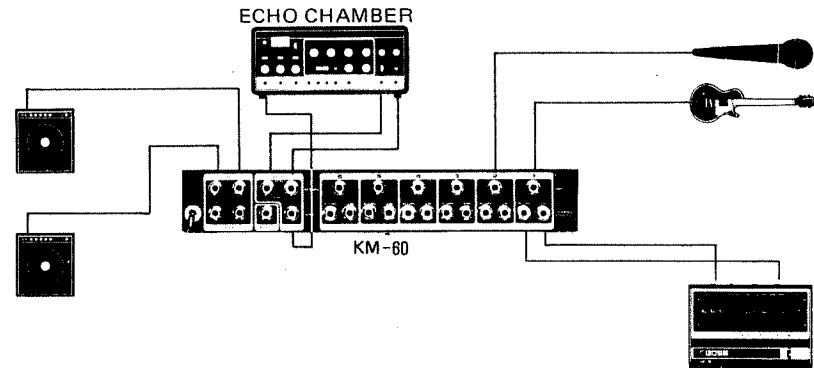

D. EXPANDING TO 12 CHANNELS BY STACKING TWO KM-60's

PARALLEL CONNECTION - I

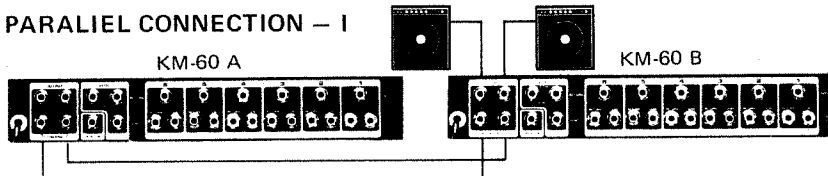

All channel volumes and master volumes of A and B units can be controlled independently. It is recommended, for example, to use A unit for the right channel and B unit for the left channel.

(Consult the block diagram carefully to make the best use of stacking function of KM-60. It will expand the mixing possibility far wider.)

PARALLEL CONNECTION - II

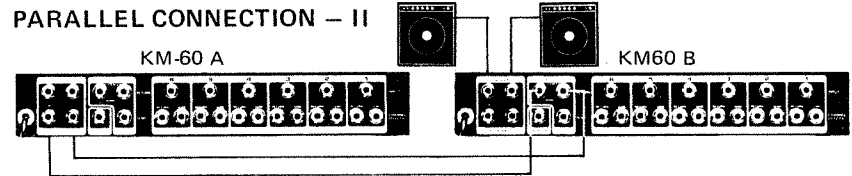

Set L and R MASTER VOLUME's of KM-60 A unit at around "6".

Set L and R EFFECTS MASTER VOLUME's of KM-60 B unit at around "3".

Both L and R outputs are taken out from KM-60 B unit. Thus volume control of all 12 channels can be accomplished by L and R MASTER VOLUME's of KM-60 B unit.

GOING INTO OPERATION

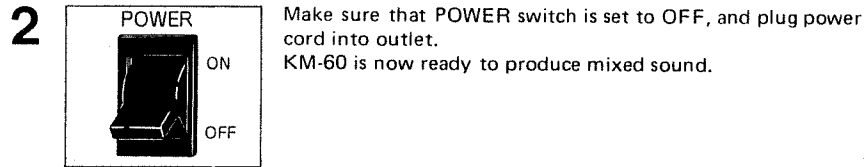
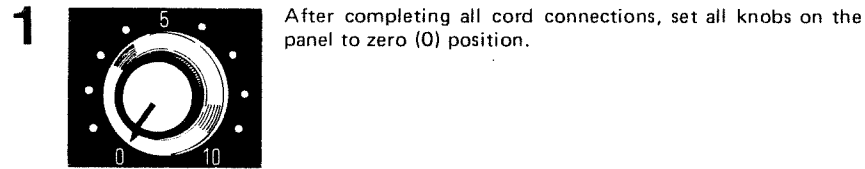

3 Set POWER switch to ON, and level meter lamp will light up.

4 Set attenuator switches to proper position to match the sources connected.

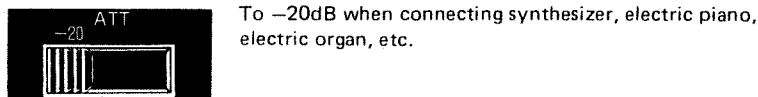
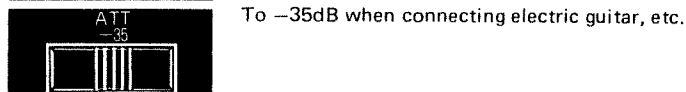
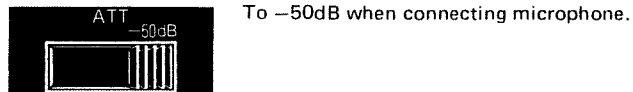

5 Set PANPOT to proper position to obtain best mixing results.

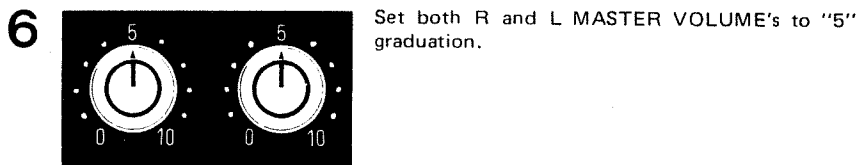

7 Set each input channel volume to proper position. Turn the knob clockwise (↻) to intensify given source, and counterclockwise (↺) to tone down.
* Volume of channel not in use or unnecessary should be set to zero "0" position.

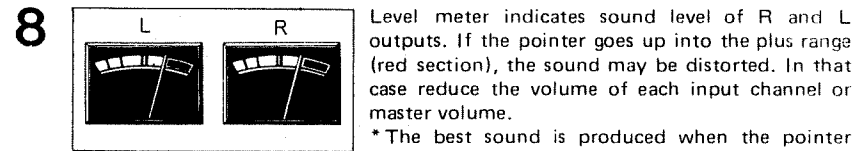

9 Set TREBLE and BASS knobs to fine-tune the sounds.

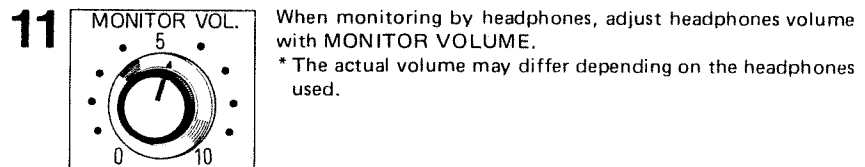
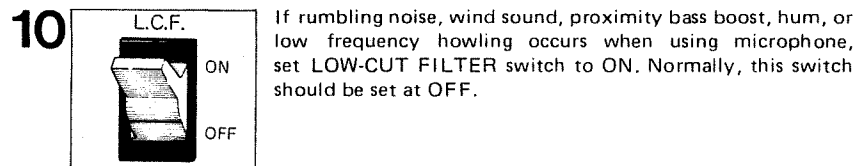

FOR "C" CONNECTION METHOD

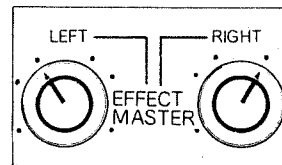
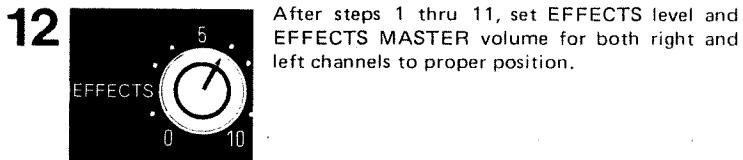

 Roland®

10177

UPC

10177



10981

 **BOSS**

Products of Roland