



Thank you, and congratulations on your choice of the Roland KD-80 V-Kick Trigger.

Before using this unit, carefully read the sections entitled: "USING THE UNIT SAFELY" (p. 3-4) and "IMPORTANT NOTES" (p. 4). These sections provide important information concerning the proper operation of the unit. Additionally, in order to feel assured that you have gained a good grasp of every feature provided by your new unit, Owner's manual should be read in its entirety. The manual should be saved and kept on hand as a convenient reference.

Before using the KD-80, you need to make the following settings.

- Head tension adjustment (p. 5)
- Settings for the percussion sound module (p. 2)

Contents of the Package

KD-80 (pad unit)



Stay



Leg x 2



Beater

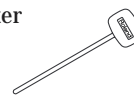

Connection Cable

Tuning Key

Owner's Manual (this manual)

* This package does not include a kick pedal. Use with a commercially available kick pedal installed on the KD-80. Please be aware that by using a felt beater, you risk causing damage to the head as a result of the metal portions of the beater that can become exposed when the felt wears thin.

Names of Components

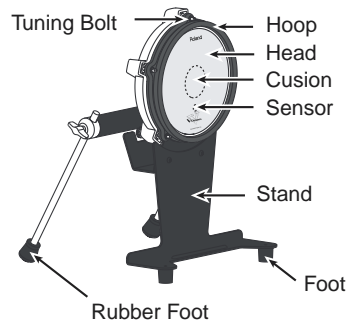
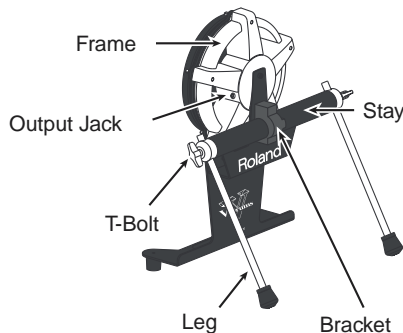

Copyright © 2001 ROLAND CORPORATION

All rights reserved. No part of this publication may be reproduced in any form without the written permission of ROLAND CORPORATION.

Recommended Settings for the Percussion Sound Module

Recommended settings for the trigger parameters when using the KD-80 with various percussion sound modules.

- The trigger parameters should be adjusted as necessary to match the actual state of your configuration, and the environment in which it is being used.
- For information on how to change the parameters for a percussion sound module, refer to the documentation for the percussion sound module you're using.

TTD-10 (TDW-1 V-Cymbal Control, TDW-1)

Trigger Type	K80
Sensitivity	8
Threshold	5
Curve	Linear
Scan Time (*1)	2.0
Retrigger Cancel (*1)	8
Mask Time (*1)	8
Xtalk Cancel (*1)	OFF
Mount Type (*1)	Separate

TD-10 (Non expanded)

Trigger Type	K2
Sensitivity	5
Threshold	0
Curve	Linear
Scan Time (*1)	2.0
Retrigger Cancel (*1)	8
Mask Time (*1)	12
Xtalk Cancel (*1)	OFF

TD-8

TRIGGER TYPE	K8
SENSITIVITY	9
THRESHOLD	3
CURVE	LINEAR
SCAN TIME	1.5
RETRIG CANCEL	5
MASK TIME	0
XTALK CANCEL	25

TD-6

TrigType	KD Type
Sensitivity	10
Threshold	4
TrigCurve	LINEAR
Xtalk Cancel	20
Scan Time	2.0
Retrig Cancel	5
Mask Time	4

TD-7 (*2)

Cross Talk Group	OFF
Velocity Curve	Norm3
Choke	OFF
Max Dyna	3
Min Dyna	1
Min Velo	1
Mask Time	12
Threshold	1

TD-5

TRIGGER TYPE	K2
SENSITIVITY	11
THRESHOLD	2
CURVE	Lnr

SPD-20

Trig Sens	12
Trig Threshold	0
Trig Type	K1
Trig Curve	0

SPD-11

Trig Sens	12
Trig Threshold	1
Trig Mask Time	12
Trig Scan Time	20

HPD-15

Input Mode	TRIGx2
Trig Type	KD-80
Trig Sens	12
Curve	Linear
Threshold	2
Scan Time	1ms
Retrig Cancel	4
Mask Time	4ms
X-Talk Rate	40%

*1: You need to set each advanced trigger parameter after setting the trigger type.

*2: Each trigger parameter can be set independently for the "head-side" and "rim-side." Set to the same value for the head and rim. Trigger parameters can be set individually for each patch.

Specifications

KD-80 (V-Kick Trigger)

Pad Size: 8 inches

Dimensions: 440 (W) x 340 (D) x 465 (H) mm 17-3/8 (W) x 13-7/16 (D) x 18-5/16 (H) inches

Weight: 4.8 kg 10 lbs 10 oz



Accessories: Owner's Manual, Connection Cable, Beater, Tuning Key



Options: Mesh Head (MH-8)

* In the interest of product improvement, the specifications, appearance of this unit and/or contents of this package are subject to change without prior notice.







USING THE UNIT SAFELY

INSTRUCTIONS FOR THE PREVENTION OF FIRE, ELECTRIC SHOCK, OR INJURY TO PERSONS

About  WARNING and  CAUTION Notices







 WARNING	Used for instructions intended to alert the user to the risk of death or severe injury should the unit be used improperly.
 CAUTION	Used for instructions intended to alert the user to the risk of injury or material damage should the unit be used improperly. * Material damage refers to damage or other adverse effects caused with respect to the home and all its furnishings, as well to domestic animals or pets.

About the Symbols







	The  symbol alerts the user to important instructions or warnings. The specific meaning of the symbol is determined by the design contained within the triangle. In the case of the symbol at left, it is used for general cautions, warnings, or alerts to danger.
	The  symbol alerts the user to items that must never be carried out (are forbidden). The specific thing that must not be done is indicated by the design contained within the circle. In the case of the symbol at left, it means that the unit must never be disassembled.
	The  symbol alerts the user to things that must be carried out. The specific thing that must be done is indicated by the design contained within the circle. In the case of the symbol at left, it means that the power-cord plug must be unplugged from the outlet.

ALWAYS OBSERVE THE FOLLOWING





WARNING

- Before using this unit, make sure to read the instructions below, and the Owner's Manual. 
- Do not open or perform any internal modifications on the unit. (The only exception would be where this manual provides specific instructions which should be followed in order to put in place user-installable options; see p. 5, p. 7.) 
- Do not attempt to repair the unit, or replace parts within it (except when this manual provides specific instructions directing you to do so). Refer all servicing to your retailer, the nearest Roland Service Center, or an authorized Roland distributor, as listed on the "Information" page. 
- Never use or store the unit in places that are:
 - Subject to temperature extremes (e.g., direct sunlight in an enclosed vehicle, near a heating duct, on top of heat-generating equipment); or are 
 - Damp (e.g., baths, washrooms, on wet floors); or are 
 - Humid; or are
 - Exposed to rain; or are
 - Dusty; or are
 - Subject to high levels of vibration.
- Make sure you always have the unit placed so it is level and sure to remain stable. Never place it on stands that could wobble, or on inclined surfaces. 



WARNING

- Do not allow any objects (e.g., flammable material, coins, pins); or liquids of any kind (water, soft drinks, etc.) to penetrate the unit. 

- In households with small children, an adult should provide supervision until the child is capable of following all the rules essential for the safe operation of the unit. 
- Do not drop the unit! 
- Keep the lock bushings and washers that you removed out of reach of small children. If a child has accidentally swallowed them, see a doctor immediately. 
- Please be aware that by using a felt beater, you risk causing damage to the head as a result of the metal portions of the beater that can become exposed when the felt wears thin. For the kick pedal, we recommend that you use only the supplied beater, or a commercially available plastic beater. 

⚠ CAUTION

- Try to prevent cords and cables from becoming entangled. Also, all cords and cables should be placed so they are out of the reach of children. 
- Never climb on top of, nor place heavy objects on the unit. 
- Do not apply excessive force to the sensor located below the center of the head. Doing so can interfere with accurate detection, and may damage it. 
- Due to the nature of the materials used in the sensor, changes in room temperature may affect the sensitivity of the sensor. 

⚠ CAUTION

- Assemble the KD-80 with care to avoid danger of pinching the fingers. 
- To keep the KD-80 from slipping or moving during play, the tips of the legs installed on the stand are pointed. Handle with care to avoid injury. 
- Be sure to tighten the head tension before use. Striking the head when the head tension is loose may damage the sensor and head. 

IMPORTANT NOTES

In addition to the items listed under “USING THE UNIT SAFELY” on page 3–4, please read and observe the following:

Placement

- Do not expose the unit to direct sunlight, place it near devices that radiate heat, leave it inside an enclosed vehicle, or otherwise subject it to temperature extremes. Also, do not allow lighting devices that normally are used while their light source is very close to the unit (such as a piano light), or powerful spotlights to shine upon the same area of the unit for extended periods of time. Excessive heat can deform or discolor the unit.
- Do not allow rubber, vinyl, or similar materials to remain on the unit for long periods of time. Such objects can discolor or otherwise harmfully affect the finish.
- Do not put anything that contains water (e.g., flower vases) on the unit. Also, avoid the use of insecticides, perfumes, alcohol, nail polish, spray cans, etc., near the unit. Swiftly wipe away any liquid that spills on the unit using a dry, soft cloth.

Maintenance

- For everyday cleaning wipe the unit with a soft, dry cloth or one that has been slightly dampened with water. To remove stubborn dirt, use a cloth impregnated with a mild, non-abrasive detergent. Afterwards, be sure to wipe the unit thoroughly with a soft, dry cloth.
- Never use benzine, thinners, alcohol or solvents of any kind, to avoid the possibility of discoloration and/or deformation.

Additional Precautions

- Use a reasonable amount of care when using the unit's buttons, sliders, or other controls; and when using its jacks and connectors. Rough handling can lead to malfunctions.
- When connecting / disconnecting all cables, grasp the connector itself—never pull on the cable. This way you will avoid causing shorts, or damage to the cable's internal elements.

Features

- Kick trigger unit with embedded-mesh head for superior playing feel, and quiet response.
- Compact, eight-inch pad allows for greater versatility when setting up.
- The four-leg stand assures outstanding stability.
- You can also play using a twin (double kick) pedal.

Adjusting the Head Tension

When adjusting, use the included tuning key.

Be sure to adjust the head tension before use.

In general, a tension that produces a strike response approximately the same as an acoustic drum will be appropriate.

NOTE

- Striking the head when the head tension is loose may damage the sensor and head.
- Should you neglect to make the appropriate settings, you could likely experience the following problems:
Sometimes it does not sound (uneven volume).
The volume is too low (reduced sensitivity).

MEMO

- On the KD-80, adjusting the head tension affects only the head response, and does not change the pitch of the sound as it would on an acoustic drum.
- The head tension will change as the instrument is used, so you should readjust when necessary.
- The head stretches when used for extended periods, so even when this is adjusted to 7.5 mm in the following procedure, you may not achieve the same degree of tension as when the head was initially adjusted. Strike the head to check the feel and response as you adjust the tension.

1. Use the included tuning key to tighten the tuning bolts.

Tighten the bolts until there is a space of approximately 7.5 mm between the frame and the hoop.

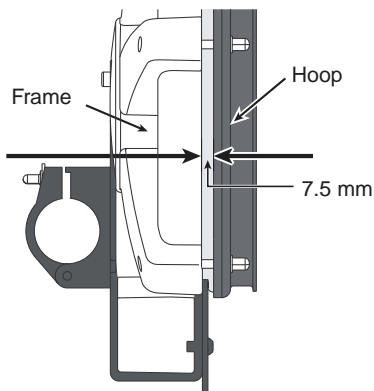

The band has a width of 7.5 mm.
Use this for adjusting the head tension.

HINT

A black, 7.5 mm strip is printed at the edge of this page. Use this as a reference when making the adjustment.

MEMO

Tighten each tuning bolt one by one, observing the numerical order shown in the diagram.

Do not firmly tighten a single tuning bolt by itself. Doing so will make it impossible to tension the head evenly, and will cause malfunctions.

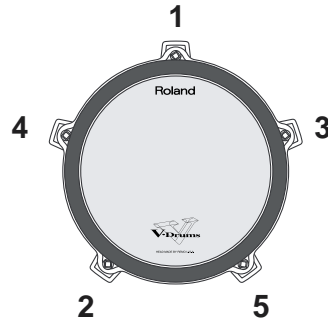

2. Fine-tune the adjustment while continuing to check the pad feel and response.

Assembling the KD-80

NOTE

Take care not to pinch your fingers between the KD-80 pad and the stand plate.

1. Place the KD-80 pad, with the head surface facing downward, on a flat surface such as the floor.
2. Use the included tuning key to loosen the bolts for the bracket on the back of the KD-80 pad, then open the bracket.
3. Mount the stay on the pad.

Align the mark on the stay with the protrusion of the bracket, and use the tuning key to firmly tighten the bolts that you loosened in step 2.

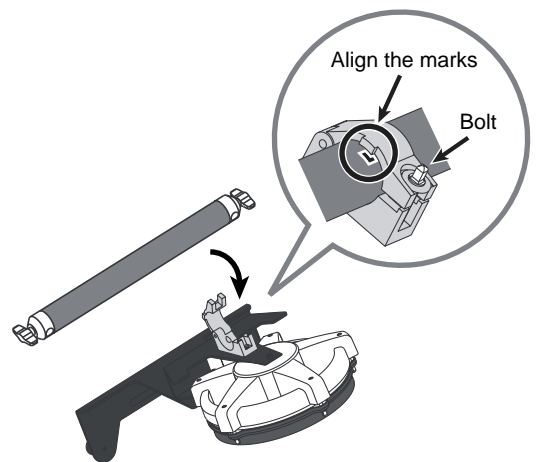

4. Loosen the leg nut.

5. Rotate the rubber foot to adjust the leg tip.

Adjust to use the spike legs when installing on carpeting or other soft surfaces, or the rubber legs when installing on flooring or other hard surfaces.

When shipped from the factory, the stand is adjusted for using the rubber legs.

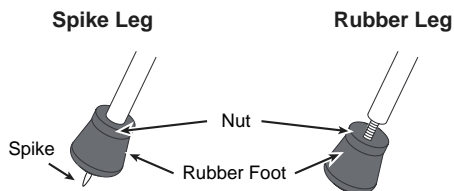

NOTE

- The tip of the spike is sharp. Handle it with care.
- When using on flooring, the spike legs may damage the floor. Adjust to use the rubber legs.

6. Tighten the nut and rubber foot to secure the rubber foot in place and keep it from loosening.

The nut and rubber foot must be tightened to prevent the malfunctions.

7. Loosen the T-bolts for the stay and mount the legs on the stay.

Install the legs as shown in the figure so that the ends of the legs protrude by about 1 inch (2 cm).

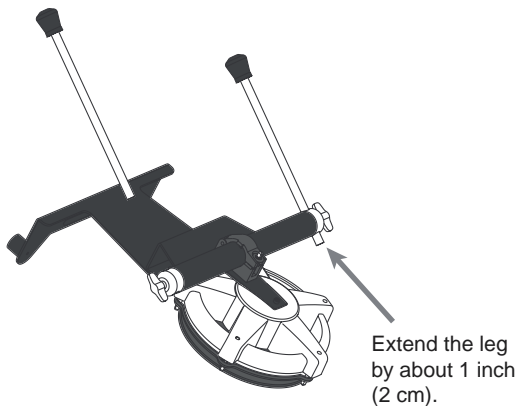

8. Tighten the T-bolts to secure the legs to the stand.

9. Lift the KD-80 and place the stand and the four legs upright.

10. Adjust the angle of the stand plate so that it's at a right angle to the floor.

Loosen the T bolts that you tightened in step 8, and adjust the length of the legs so that the stand plate is vertical to the floor. Then firmly tighten the T bolts.

11. Install the included beater on your kick pedal.

12. Mount the kick pedal on the KD-80.

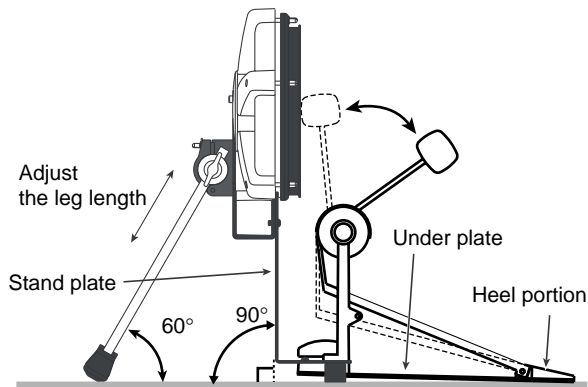

NOTE

- Install the kick pedal securely.
- Set the KD-80 so no mechanical noise is heard when you step on pedal.
- Make sure that KD-80 does not touch the drum stand or the other pads.

MEMO

If you are using a kick pedal with an under plate

Adjust the length of the legs so that the four legs of the KD-80 and the heel of the kick pedal contact the floor evenly.

13. Adjust the striking point for the beater.

The beater's striking point is adjusted to fall at the center of the head.

Adjust the striking point so that it doesn't extend beyond the cushion on the back of the head.

When Using a Twin (Double Kick) Pedal

With the KD-80, you can also play using a twin (double kick) pedal.

Set this up so the striking points of the two beaters fall at equal distances to the left and right of the center of the head.

NOTE

When using a twin (double kick) pedal, as with a regular pedal, use the included beater or a plastic beater as the beater for the kick pedal.

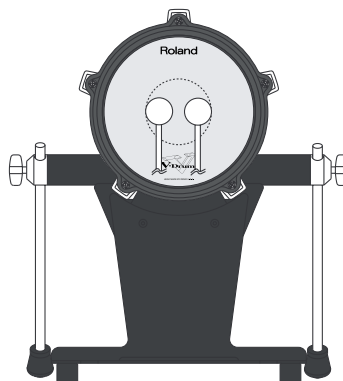

Connecting To A Percussion Sound Module

Connecting to a percussion sound module (TD-10, TD-8, TD-7, TD-6, TD-5, HPD-15, SPD-20, SPD-11, etc.).



When you have finished connecting to your percussion sound module, refer to the recommended parameters on p. 2, and make the settings for the sound module.



- To prevent malfunction and/or damage to speakers or other devices, always turn down the volume, and turn off the power on all devices before making any connections.
- Use the included cable to make connections.
- Connect the L-shaped plug of the included cable to the KD-80. This will prevent strain from being applied to the KD-80.
- Make sure that KD-80 does not touch the drum stand or the other pads.

Percussion Sound Module	Trigger Input
TD-5, TD-6, TD-7, TD-10	1 (KICK)
TD-8	1/2 (KICK)
HPD-15	1, 2
SPD-20	1
SPD-11	EXT INPUT 1



If you wish to connect two KD-80 units to trigger inputs 1/2 (KICK1/2) of the TD-8, please use the optional cable (PCS-31) or standard insert cable. The white plug is for trigger input 1, and the red plug is for trigger input 2.

Head Replacement

When the Head Should Be Replaced

The head is an expendable item that eventually will wear out and need to be replaced. Replace the head when the following occurs:

- **The head surface is torn**
- **Slack portions remain in the head even when the head tension is properly adjusted.**

Replacement heads (optional): MH-8 Mesh Head

Replacing the Head

1. Remove the kick pedal from the KD-80.
2. Remove all tuning bolts and washers from the KD-80.

Press the lock bushing (in figure below) in place with your finger as you remove each tuning bolt, to prevent the bushings from being pulled off the frame.

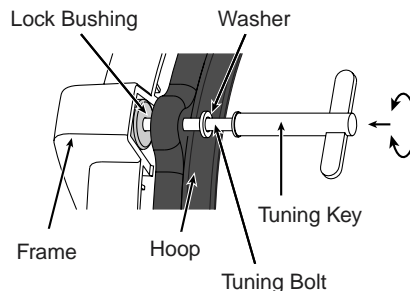

The lock bushings prevent rotation and loosening of the tuning bolts caused by vibrations that are transmitted from the hoop as you play.

3. Remove the hoop.
4. Remove the old head.
5. Place the new head on the frame.
6. Place the hoop onto the head.
7. Pass the tuning bolts through the washers, then attach them to the hoop and frame.
8. Next, adjust the tension of the head. Refer to "Adjusting the Head Tension" (p. 5).



Do not firmly tighten a single tuning bolt by itself. Doing so will make it impossible to tension the head evenly, and will cause malfunctions.



If a lock bushing happens to become separated from the frame while the head is being replaced, position the bushing so its four slots are aligned with the corresponding ridges in the frame, then press down firmly on the bushing.

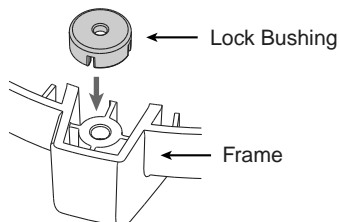

Information

When you need repair service, call your nearest Roland Service Center or authorized Roland distributor in your country as shown below.

AFRICA

EGYPT

Al Fanny Trading Office
9, EBN Hagar A1 Askalany Street,
ARD El Golf, Heliopolis,
Cairo 11341, EGYPT
TEL: 20-2-417-1828

REUNION

Maison FO - YAM Marcel
25 Rue Jules Hermann,
Chaudron - BP79 97 491
Ste Clotilde Cedex,
REUNION ISLAND
TEL: (0262) 218-429

SOUTH AFRICA

That Other Music Shop (PTY) Ltd.
11 Melle St., Braamfontein,
Johannesbourg, SOUTH AFRICA
P.O.Box 32918, Braamfontein 2017
Johannesbourg, SOUTH AFRICA
TEL: (011) 403 4105

Paul Bothner (PTY) Ltd.
17 Werdmuller Centre,
Main Road, Claremont 7708
SOUTH AFRICA
P.O. BOX 23032, Claremont 7735,
SOUTH AFRICA
TEL: (021) 674 4030

ASIA

CHINA

Roland Shanghai Electronics Co., Ltd.
5F, No.1500 Pingliang Road
Shanghai, CHINA
TEL: (021) 5580-0800

Roland Shanghai Electronics Co., Ltd. (BEIJING OFFICE)
10F, No.18 Anhuaxili
Chaoyang District, Beijing,
CHINA
TEL: (010) 6426-5050

HONG KONG

Tom Lee Music Co., Ltd. Service Division
22-32 Pun Shan Street, Tsuen
Wan, New Territories,
HONG KONG
TEL: 2415 0911

INDIA

Rivera Digitech (India) Pvt. Ltd.
409, Nirman Kendra Mahalaxmi
Flats Compound Off. Dr. Edwin
Moses Road, Mumbai-400011,
INDIA
TEL: (022) 2493 9051

INDONESIA

PT Citra IntiRama
Jl. Cideng Timur No. 15J-150
Jakarta Pusat
INDONESIA
TEL: (021) 6324170

KOREA

Cosmos Corporation
1461-9, Seocho-Dong,
Seocho Ku, Seoul, KOREA
TEL: (02) 3486-8855

MALAYSIA

BENTLEY MUSIC SDN BHD
140 & 142, Jalan Bukit Bintang
55100 Kuala Lumpur, MALAYSIA
TEL: (03) 2144-3333

PHILIPPINES

G.A. Yupango & Co. Inc.
339 Gil J. Puyat Avenue
Makati, Metro Manila 1200,
PHILIPPINES
TEL: (02) 899 9801

SINGAPORE

Sweet Lee Company
150 Sims Drive,
SINGAPORE 387381
TEL: 6246-3676

CRISTOFORI MUSIC PTE LTD

Blok 3014, Bedok Industrial Park E,
#02-2148, SINGAPORE 489980
TEL: 6243-9555

TAIWAN

ROLAND TAIWAN ENTERPRISE CO., LTD.
Room 5, 9fl. No. 112 Chung Shan
N. Road Sec.2, Taipei, TAIWAN,
R.O.C.
TEL: (02) 2561 3339

THAILAND

Theera Music Co., Ltd.
330 Verg NakornKasem, Soi 2,
Bangkok 10100, THAILAND
TEL: (02) 2248821

VIETNAM

Saigon Music
138 Tran Quang Khai St.,
District 1
Ho Chi Minh City
VIETNAM
TEL: (08) 844-4068

AUSTRALIA/NEW ZEALAND

AUSTRALIA

Roland Corporation Australia Pty., Ltd.
38 Campbell Avenue
Dee Why West, NSW 2099
AUSTRALIA
TEL: (02) 9982 8266

NEW ZEALAND

Roland Corporation Ltd.
32 Shaddock Street, Mount Eden,
Auckland, NEW ZEALAND
TEL: (09) 3098 715

CENTRAL/LATIN AMERICA

ARGENTINA

Instrumentos Musicales S.A.
Av. Santa Fe 2055
(1123) Buenos Aires
ARGENTINA
TEL: (011) 4508-2700

BRAZIL

Roland Brasil Ltda
Rua San Jose, 780 Sala B
Parque Industrial San Jose
Cotia - Sao Paulo - SP, BRAZIL
TEL: (011) 4615 5666

COSTA RICA

JUAN Bansbach Instrumentos Musicales
Ave.1, Calle 11, Apartado 10237,
San Jose, COSTA RICA
TEL: 258-0211

CHILE

Comercial Fancy II S.A.
Rut.: 96.919.420-1
Nataliel Cox #739, 4th Floor
Santiago - Centro, CHILE
TEL: (02) 688-9540

EL SALVADOR

OMNI MUSIC
75 Avenida Norte y Final
Alameda Juan Pablo II,
Edificio No.4010 San Salvador,
EL SALVADOR
TEL: 262-0788

MEXICO

Casa Veerkamp, s.a. de c.v.
Av. Toluca No. 323, Col. Olivar
de los Padres 01780 Mexico D.F.
MEXICO
TEL: (55) 5668-6699

PANAMA

SUPRO MUNDIAL, S.A.
Boulevard Andrews, Albrook,
Panama City, REP. DE PANAMA
TEL: 315-0101

PARAGUAY

Distribuidora De Instrumentos Musicales
J.E. Olear y ESQ. Manduvira
Asuncion PARAGUAY
TEL: (021) 492-124

URUGUAY

Todo Musica S.A.
Francisco Acuna de Figueroa 1771
C.P.: 11.800
Montevideo, URUGUAY
TEL: (02) 924-2335

VENEZUELA

Musicaland Digital C.A.
Av. Francisco de Miranda,
Centro Parque de Cristal, Nivel
C2 Local 20 Caracas
VENEZUELA
TEL: (212) 285-8586

EUROPE

AUSTRIA

Roland Austria GES.M.B.H.
Siemensstrasse 4, P.O. Box 74,
A-6063 RUM, AUSTRIA
TEL: (0512) 26 44 260

BELGIUM/HOLLAND/LUXEMBOURG

Roland Benelux N. V.
Houtstraat 3, B-2260, Oevel
(Westerlo) BELGIUM
TEL: (014) 575811

DENMARK

Roland Scandinavia A/S
Nordhavnsvej 7, Postbox 880,
DK-2100 Copenhagen
DENMARK
TEL: 3916 6200

FRANCE

Roland France SA
4, Rue Paul Henri SPAAK,
Parc de l'Esplanade, F 77 462 St.
Thibault, Lagny Cedex FRANCE
TEL: 01 600 73 500

FINLAND

Roland Scandinavia As, Filial Finland
Elanontie 5
FIN-01510 Vantaa, FINLAND
TEL: (09) 68 24 020

GERMANY

Roland Elektronische Musikinstrumente HmbH.
Oststrasse 96, 22844 Norderstedt,
GERMANY
TEL: (040) 52 60090

GREECE

STOLLAS S.A. Music Sound Light
155, New National Road
Patras 26442, GREECE
TEL: 2610 435400

HUNGARY

Roland East Europe Ltd.
Warehouse Area 'DEPO' Pf.83
H-2046 Torokbalint, HUNGARY
TEL: (23) 511011

IRELAND

Roland Ireland
Audio House, Belmont Court,
Donnybrook, Dublin 4,
Republic of IRELAND
TEL: (01) 2603501

ITALY

Roland Italy S. p. A.
Viale delle Industrie 8,
20020 Arese, Milano, ITALY
TEL: (02) 937-78300

NORWAY

Roland Scandinavia Avd. Kontor Norge
Lilleakerveien 2 Postboks 95
Lilleaker N-0216 Oslo
NORWAY
TEL: 2273 0074

POLAND

P. P. H. Brzostowicz
UL. Gibraltarska 4,
PL-03664 Warszawa POLAND
TEL: (022) 679 44 19

PORTUGAL

Tecnologias Musica e Audio, Roland Portugal, S.A.
Cais Das Pedras, 8/9-1 Dto
4050-485 PORTO
PORTUGAL
TEL: (022) 608 00 60

ROMANIA

FBS LINES
Piata Libertatii 1,
RO-4200 Gheorghiehi
TEL: (095) 169-5043

RUSSIA

MuTek
3-Bogatyrskaya Str. 1.k.1
107 564 Moscow, RUSSIA
TEL: (095) 169 5043

SPAIN

Roland Electronics de España, S. A.
Calle Bolivia 239, 08020
Barcelona, SPAIN
TEL: (93) 308 1000

SWEDEN

Roland Scandinavia A/S SWEDISH SALES OFFICE
Danvik Center 28, 2 tr.
S-131 30 Nacka SWEDEN
TEL: (08) 702 00 20

SWITZERLAND

Roland (Switzerland) AG
Landstrasse 5, Postfach,
CH-4452 Ittingen,
SWITZERLAND
TEL: (061) 927-8383

UKRAINE

TIC-TAC
Mira Str. 19/108
P.O. Box 180
295400 Munkachevo, UKRAINE
TEL: (03131) 414-40

UNITED KINGDOM

Roland (U.K.) Ltd.
Atlantic Close, Swansea
Enterprise Park, SWANSEA
SA7 9FJ,
UNITED KINGDOM
TEL: (01792) 702701

MIDDLE EAST

BAHRAIN

Moon Stores
No.16, Bab Al Bahrain Avenue,
P.O.Box 247, Manama 304,
State of BAHRAIN
TEL: 211 005

CYPRUS

Radex Sound Equipment Ltd.
17, Diagorou Street, Nicosia,
CYPRUS
TEL: (022) 66-9426

IRAN

MOCO, INC.
No.41 Nike St., Dr.Shariyati Ave.,
Roberoye Cerahe Mirdamad
Tehran, IRAN
TEL: (021) 285-4169

ISRAEL

Hailit P. Greenspoon & Sons Ltd.
8 Retzif Ha'aliya Hashnya St.
Tel-Aviv-Yafo ISRAEL
TEL: (03) 6823666

JORDAN

AMMAN Trading Agency
245 Prince Mohammad St.,
Amman 1118, JORDAN
TEL: (06) 464-1200

KUWAIT

Easa Husain Al Yousifi Est.
Abdullah Salem Street,
Safat, KUWAIT
TEL: 243-6399

LEBANON

Chahine S.A.L.
Gerge Zeidan St., Chahine Bldg.,
Achrafieh, P.O.Box: 16-5857
Beirut, LEBANON
TEL: (01) 20-1441

QATAR

Al Emadi Co. (Badie Studio & Stores)
P.O. Box 62,
Doha, QATAR
TEL: 4423-554

SAUDI ARABIA

aDawlah Universal Electronics APL
Corniche Road, AlDossary Bldg.,
1st Floor, Alkhobar,
SAUDI ARABIA

P.O.Box 2154, Alkhobar 31952
SAUDI ARABIA
TEL: (03) 898 2081

SYRIA

Technical Light & Sound Center
Khaled Ebn Al Walid St.
Bldg. No. 47, P.O.BOX 13520,
Damascus, SYRIA
TEL: (011) 223-5384

TURKEY

Barkat muzik aletleri ithalat ve ihracat Ltd Sti
Siraselviler Caddesi Siraselviler
Pasaji No:74/20
Taksim - Istanbul, TURKEY
TEL: (0212) 2499324

U.A.E.

Zak Electronics & Musical Instruments Co. L.L.C.
Zabeel Road, Al Sherooq Bldg.,
No. 14, Grand Floor, Dubai, U.A.E.
TEL: (04) 3360715

NORTH AMERICA

CANADA

Roland Canada Music Ltd. (Head Office)
5480 Parkwood Way Richmond
B. C., V6V 2M4 CANADA
TEL: (604) 270 6626

Roland Canada Music Ltd. (Toronto Office)

170 Admiral Boulevard
Mississauga On L5T 2N6
CANADA
TEL: (905) 362 9707

U. S. A.

Roland Corporation U.S.
5100 S. Eastern Avenue
Los Angeles, CA 90040-2938,
U. S. A.
TEL: (323) 890 3700

As of April 1, 2003 (Roland)