

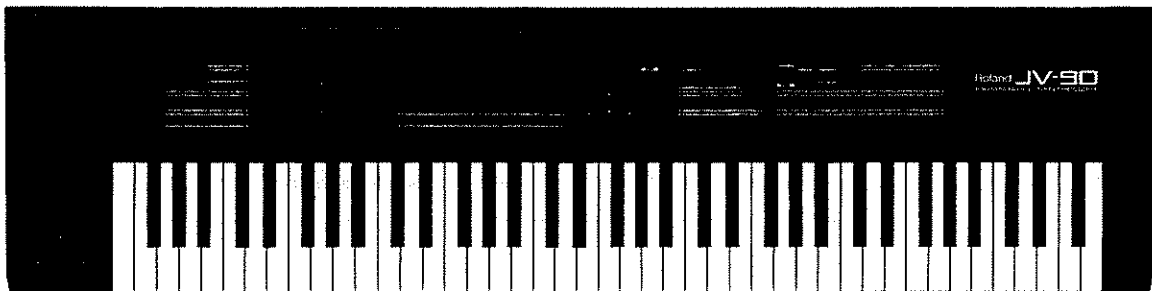

Roland®

EXPANDABLE SYNTHESIZER

JV-90

OWNER'S MANUAL



	CAUTION RISK OF ELECTRIC SHOCK DO NOT OPEN	
ATTENTION: RISQUE DE CHOC ELECTRIQUE NE PAS OUVRIR		
CAUTION: TO REDUCE THE RISK OF ELECTRIC SHOCK, DO NOT REMOVE COVER (OR BACK). NO USER-SERVICEABLE PARTS INSIDE. REFER SERVICING TO QUALIFIED SERVICE PERSONNEL.		



The lightning flash with arrowhead symbol, within an equilateral triangle, is intended to alert the user to the presence of uninsulated "dangerous voltage" within the product's enclosure that may be of sufficient magnitude to constitute a risk of electric shock to persons.



The exclamation point within an equilateral triangle is intended to alert the user to the presence of important operating and maintenance (servicing) instructions in the literature accompanying the product.

INSTRUCTIONS PERTAINING TO A RISK OF FIRE, ELECTRIC SHOCK, OR INJURY TO PERSONS.

IMPORTANT SAFETY INSTRUCTIONS

SAVE THESE INSTRUCTIONS

WARNING - When using electric products, basic precautions should always be followed, including the following:

1. Read all the instructions before using the product.
2. Do not use this product near water — for example, near a bathtub, washbowl, kitchen sink, in a wet basement, or near a swimming pool, or the like.
3. This product should be used only with a cart or stand that is recommended by the manufacturer.
4. This product, either alone or in combination with an amplifier and headphones or speakers, may be capable of producing sound levels that could cause permanent hearing loss. Do not operate for a long period of time at a high volume level or at a level that is uncomfortable. If you experience any hearing loss or ringing in the ears, you should consult an audiologist.
5. The product should be located so that its location or position does not interfere with its proper ventilation.
6. The product should be located away from heat sources such as radiators, heat registers, or other products that produce heat.
7. The product should be connected to a power supply only of the type described in the operating instructions or as marked on the product.
8. The power-supply cord of the product should be unplugged from the outlet when left unused for a long period of time.
9. Care should be taken so that objects do not fall and liquids are not spilled into the enclosure through openings.
10. The product should be serviced by qualified service personnel when:
 - A. The power-supply cord or the plug has been damaged; or
 - B. Objects have fallen, or liquid has been spilled onto the product; or
 - C. The product has been exposed to rain; or
 - D. The product does not appear to operate normally or exhibits a marked change in performance; or
 - E. The product has been dropped, or the enclosure damaged.
11. Do not attempt to service the product beyond that described in the user-maintenance instructions. All other servicing should be referred to qualified service personnel.

For the USA

This product may be equipped with a polarized line plug (one blade wider than the other). This is a safety feature. If you are unable to insert the plug into the outlet, contact an electrician to replace your obsolete outlet. Do not defeat the safety purpose of the plug.

For Canada

For Polarized Line Plug

CAUTION: TO PREVENT ELECTRIC SHOCK, MATCH WIDE BLADE OF PLUG TO WIDE SLOT, FULLY INSERT.

ATTENTION: POUR ÉVITER LES CHOCs ÉLECTRIQUES, INTRODUIRE LA LAME LA PLUS LARGE DE LA FICHE DANS LA BORNE CORRESPONDANTE DE LA PRISE ET POUSSER JUSQU' AU FOND.

For the U.K.

IMPORTANT: THE WIRES IN THIS MAINS LEAD ARE COLOURED IN ACCORDANCE WITH THE FOLLOWING CODE.

BLUE	: NEUTRAL
BROWN	: LIVE

As the colours of the wires in the mains lead of this apparatus may not correspond with the coloured markings identifying the terminals in your plug, proceed as follows:

The wire which is coloured BLUE must be connected to the terminal which is marked with the letter N or coloured BLACK.
 The wire which is coloured BROWN must be connected to the terminal which is marked with the letter L or coloured RED.

Roland **JV-90**
EXPANDABLE SYNTHESIZER

INTRODUCTION

Thank you for purchasing the Roland JV-90 Expandable Synthesizer. The JV-90 allows you to create a wide variety of sonic textures by digitally manipulating the high-quality on-board sounds. By installing an optional Voice Expansion Board, you can increase the number of sounds available and the instrument's maximum polyphony. When fully expanded, the JV-90 is a versatile instrument that can be used for live performances, studio recordings and desk-top music applications.

To take full advantage of the JV-90's features and functions, please take the time to read this operation manual.

FEATURES

- **Several Performance Modes**

The Patch Play mode (Page 26) allows you to control different sounds in real-time, and the Performance Play mode (Page 31) allows you to spontaneously control 8 Parts and MIDI channels. In addition, a number of Key Modes can enhance any performance.

- **Voice Expandability**

If an optional Voice Expansion Board is installed, 28 voices and more sounds (Parts) are added to the 28 voices already provided by the JV-90. (Page 102)

- **A Selection of Several Waveforms**

Not only will you find basic waveforms (sawtooth, square wave, pulse waves etc.), but a wide variety of unusual waveforms are provided as well. (Page 55) By modifying these waveforms with FXM (Frequency Cross Modulation) (Page 55), even more sophisticated sounds can be achieved. And by using optional PCM cards or Wave Expansion Boards (Page 55), new waveforms can be added.

- **Realtime Parameter Control**

The JV-90's sliders and optional footswitches and pedals can be used to change the instrument's parameters in realtime.

- **Velocity/Aftertouch Sensitive Keyboard**

The JV-90's 76-note keyboard features Velocity sensitivity (Page 62) and Aftertouch sensitivity (Page 54); two features which enhance any performance.

IMPORTANT NOTES

In addition to the items listed under Safety Precautions inside the front cover, please read and observe the following:

[Power Supply]

- Before connecting this unit to other devices, turn off the power to all units; this will help prevent damage or malfunction.
- Do not use this unit on the same power circuit with any device that will generate line noise; an electric motor or variable lighting system for example.

[Placement]

- Using the unit near power amplifiers (or other equipment containing large power transformers) may induce hum.

This device may interfere with radio and television reception. Do not use this device in the vicinity of such receivers.

- Do not expose the unit to temperature extremes or install it near devices that radiate heat. Direct sunlight in an enclosed vehicle can deform or discolor the unit.

[Maintenance]

- For everyday cleaning wipe the unit with a soft, dry cloth or one that has been slightly dampened with water. To remove stubborn dirt, use a mild, non-abrasive detergent. Afterwards, be sure to wipe the unit thoroughly with a soft, dry cloth.

- Never use benzene, thinners, alcohol or solvents of any kind, to avoid the possibility of discoloration and/or deformation.

[Additional Precautions]

- Protect the unit from strong impact.
- Never strike or apply strong pressure to the display.
- A small amount of heat will radiate from the unit during normal operation.
- Before using the unit in a foreign country, consult with qualified service personnel.
- A small amount of noise may be heard from the display during normal operation.

[Memory Backup]

- This unit contains a battery which powers the unit's memory circuits while the main (AC) power is off. The expected life of this battery is 5 years or more. However, to avoid the untimely loss of memory data, it is strongly recommended that you change the battery every 5 years. Please be aware that the actual life of the battery will depend upon the physical environment — especially the temperature — in which the unit is used. When it is time to change the battery, consult with qualified service personnel.

- When the battery becomes weak the following message will appear in the display: "Internal Battery Low". Please change the battery as soon as possible to avoid the loss of memory data.

- Please be aware that the contents of memory may at times be lost; when the unit is sent for repairs or when by some chance a malfunction has occurred. Important data should be stored on a RAM card, or written down on paper (if possible). During repairs, due care is taken to avoid the loss of data. However, in certain cases (such as when circuitry related to memory itself is out of order), we regret that it may not be possible to restore the data.

About this owner's manual

Parameter names are often abbreviated in the instrument's display. For example, Key Mode is abbreviated as 'Mode,' and Chorus Rate as 'ChoRate.' The full name of the parameter will be used in the manual to avoid any confusion.

If a parameter's value is continuously variable, it will be shown as being a number from 0—127. If, on the other hand, a parameter value is selectable in discrete steps, those steps will be shown as -100/-50/0/50/100 (for example).

Panel buttons are indicated within square brackets [], such as [CHORUS].

Regarding Screen Displays

Where possible, we will use the actual screen displays for explanations. Keep in mind, however, that the displays of your JV-90 may vary slightly depending on your instrument's

CONTENTS

- INTRODUCTION
- FEATURES
- IMPORTANT NOTES
- CONTENTS

Chapter 1: Quick Start

■ Setup	12
■ Power On/Off	14
■ Playing the demonstration songs	15
■ Changing Patches (PATCH Play Mode)	16
■ Altering the sound on the JV-90	17
■ Playing Rhythm sounds (RHYTHM Play Mode)	18
■ Mixing different sounds (PERFORMANCE Play Mode)	18
■ Using the three Key Modes (Layer, Zone and Single)	19
■ Creating original sounds (EDIT PALETTE)	20
■ Write Procedure	21
■ Note on transmitting MIDI messages from the JV-90 (INT ZONE, TX ZONE)	22
■ If stuck notes occur ... (PANIC)	22

Chapter 2: Performance and Realtime-Edit in The Play Mode

1. Patch Play mode	26
■ About the Patch Play mode	26
■ Operation guide	27
● How to use the TONE SWITCH buttons	27
● Use the edit assign buttons to select parameters	27
● Parameters you can adjust while in Patch Play mode	28
2. Performance Play mode	31
■ About the Performance Play mode	31
■ Operation guide	32
● How to use the PART SWITCH buttons	32
● The Part Information function	32
■ Parameters accessible from Performance Play mode	33
● Performance play mode parameter list	35
3. Rhythm Play mode	37
■ About the Rhythm Play mode	37
■ How to select and modify parameters	37

4. Play mode	38
■ System Common parameters	38
● When Pressing [TUNE]	38
● When Pressing [CONTROL]	41
● When Pressing [MIDI]	42
● RX PART SWITCH	44
■ Effect parameters	45
● When Pressing [EFFECT]	45
■ Transmit a Program Change message	46
● When Pressing [PGM CHANGE]	46

Chapter 3: Details of the Edit Operations

1. Patch Edit mode	48
■ About the Patch Edit mode	48
■ Operation guide	48
● Patch editing procedure	48
● How to use the TONE SELECT buttons	49
■ About the parameters	50
● Parameters accessed by pressing [COMMON]	50
● Parameters accessed by pressing [EFFECT]	51
● Parameters accessed by pressing [CONTROL]	53
● Parameters accessed by pressing [WAVE/LFO]	55
● Parameters accessed by pressing [PITCH]	57
● Parameters accessed by pressing [TVF]	59
● Parameters accessed by pressing [TVA]	62
2. Performance Edit mode	65
■ About the Performance Edit mode	65
■ Operation guide	65
● Performance Edit procedure	65
■ Explanation of parameters	67
● Parameters accessed by pressing [COMMON]	67
● Parameters accessed by pressing [EFFECT]	68
● Parameters accessed by pressing [TX ZONE]	70
● Parameters accessed by pressing [INT ZONE]	73
● Parameters accessed by pressing [PART]	75

3. Rhythm Edit mode	78
■ About the Rhythm Edit mode	78
■ Procedure	78
● Rhythm editing procedure	78
■ Explanation of parameters	80
● Parameters accessed by pressing [EFFECT]	80
● Parameters accessed by pressing [CONTROL]	81
● Parameters accessed by pressing [WAVE/LFO]	82
● Parameters accessed by pressing [PITCH]	83
● Parameters accessed by pressing [TVF]	84
● Parameters accessed by pressing [TVA]	85
4. Commands	87
■ Write mode	87
■ Operation guide	87
■ Write	88
● Copy	91
● Initialize	94
● Card	95
● Bulk (bulk dump)	96
● Protect	99

Chapter 4: Using a Voice Expansion Board

1. Using a Voice Expansion Board	
■ Using a Voice Expansion Board	102
● Modes	102
● Two Types of Voice Expansion Boards	102
● Structure of the VE-GS1	102
● Structure of the VE-JV1	103
● VE-GS1 Maximum Polyphony	103
● The VE-GS1's Sound Parameters are Part Parameters	103
● When the value in the screen differs from that on the Voice Expansion Board	103
● V-EXP MIDI IN Selector Switch	104
2. Using the VE-JV1 Voice Expansion Board	
● Select the Voice Expansion Play Mode	105
● How to select the Part to be played from the keyboard	105
● How to change sounds in a Part	105
● How to edit the Sound Parameters of the VE-JV1	105

3. Using the VE-GS1 Voice Expansion Board

● Select the Voice Expansion Play Mode	106
● How to select the Part to be played from the keyboard	106
● Part On/Off(play/mute)	106
● How to change sounds in a Part	106
● How to edit the sound parameters of the VE-GS1	108
● Other Editing Procedures	113

Chapter 5: REFERENCE

1. Error Messages	118
2. Troubleshooting	120
3. Waveform List	126
4. Preset Data	127
■ Internal	127
■ Preset A	127
■ Preset B	128
■ Preset C	128
■ Preset D	129
■ JV-80 Compatible Preset a	130
■ JV-80 Compatible Preset b	130
■ Rhythm Set	131
■ JV-80 Compatible Rhythm Set	133
5. MIDI Reference	
■ Roland Exclusive Messages	134
■ MIDI Implementation	136
■ MIDI Implementation Chart	148
6. Index	150
7. Specifications	154

PANEL DESCRIPTIONS

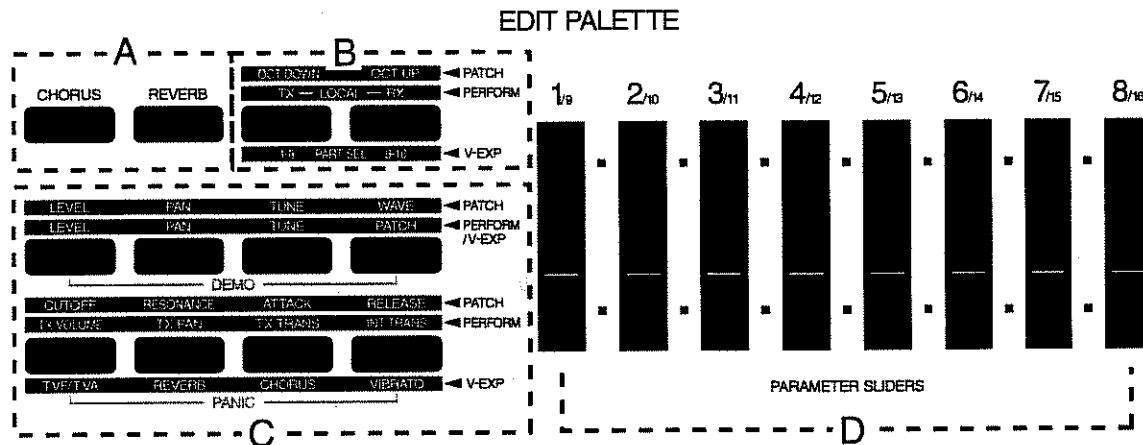

The buttons on the JV-90's front panel function differently depending on which mode (Patch/Performance/Rhythm/Expansion) is currently selected. Therefore, always determine which mode is selected before using the buttons. (See Mode Buttons G)

Front Panel

EDIT PALETTE

A. Chorus Button, Reverb Button

These buttons turn the digital effects on and off.

B. TX Button, RX Button : Octave Buttons : Part Select Buttons

Patch Mode : These buttons shift the pitch of the sounds being played from the keyboard one octave up or down.

Performance Mode : These buttons determine how the Part Switch Buttons (F) should function. You can transmit or receive MIDI data and turn the Local Control setting on or off. (See page 32.)

Voice Expansion Mode : These buttons select Parts 1 - 8 and 9 - 16. (See page 106.)

C. Edit Assign Buttons

In the Play mode of a Patch or Performance, or in Voice Expansion mode, these buttons are used for selecting the parameter to be edited and assigning it to a slider. The selected parameter can then be edited by moving the slider.

D. Parameter Slider

Using this slider, you can continuously change the value of the parameter currently selected when editing a sound or controlling an external MIDI device. If you move the slider while holding [ENTER] (J) down, the cursor will move without the value being changed.

E. LCD (Liquid Crystal Display)

The display shows the currently selected sound, waveform, name or value of the parameter being used, etc.

F.

Tone Switches 1 - 4

In the Patch Play or Patch Edit mode, you can turn Tones on and off independently with the relevant button. When a Tone is on, the corresponding indicator will light.

Tone Select Switches 1 - 4

In the Patch Edit mode, you can select the Tone to be edited using these buttons.

Part Switches 1 - 8

In the Performance Play or Performance Edit mode, you can turn specific Parts on and off, or determine whether or not to transmit/receive MIDI messages. These buttons will function differently depending on the settings. (See page 32.)

MODE

G. Mode Buttons

These buttons are used to select the following modes:

Patch Mode : This mode allows you to monitor or edit sounds. (See page 26.)

Performance Mode : This mode allows you to play more than one sound at a time, and therefore may be selected for desk top music (DTM) applications. (See page 31.)

Rhythm Mode : This mode allows you to play percussion sounds. (See page 37.)

Voice Expansion Mode : This mode should be used for playing (or editing) the sounds on the optional Voice Expansion Board. The parameters of a Roland GS sound module (connected via MIDI) can also be edited on the JV-90's screen in this mode. (See page 106.)

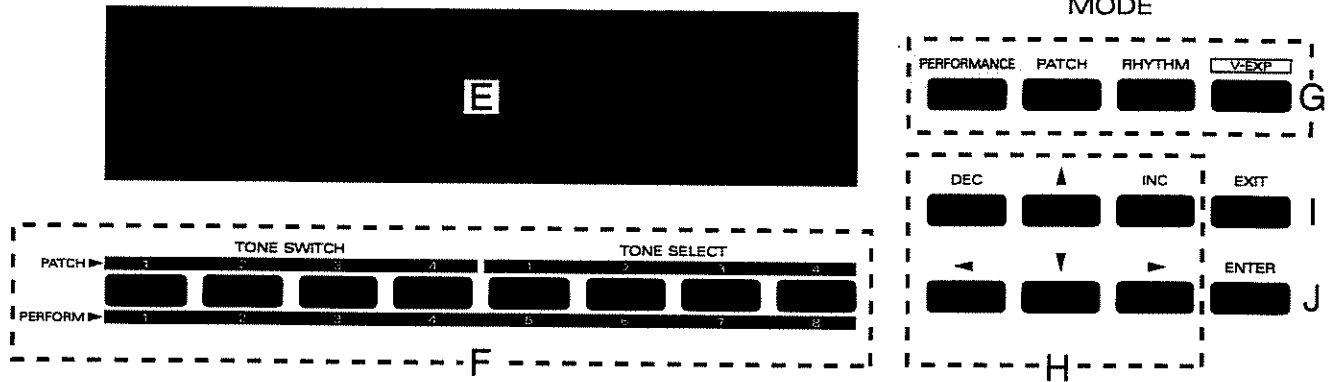

H. INC/DEC Buttons
 Using these buttons, you can change the value of the parameter currently selected. Pressing [DEC] decreases the value while pressing [INC] increases it. If you press and hold [DEC], the value will change continually. If you press [INC] while holding [DEC] down, the value will change more rapidly.

Page Buttons ([▲]/[▼])
 Use these buttons to change displays pages.

Cursor Buttons ([◀]/[▶])
 Use these buttons to move the cursor in the screen or select a command.

I. EXIT Button
 Press this button to cancel a procedure before it is completed. Pressing the button will retrieve the previous display.

J. ENTER Button
 Press this button to execute the selected command or function.

FUNCTION

K. FUNCTION Button
 Use these buttons to select a function or parameter. The parameter shown in the screen will depend on the mode currently selected.

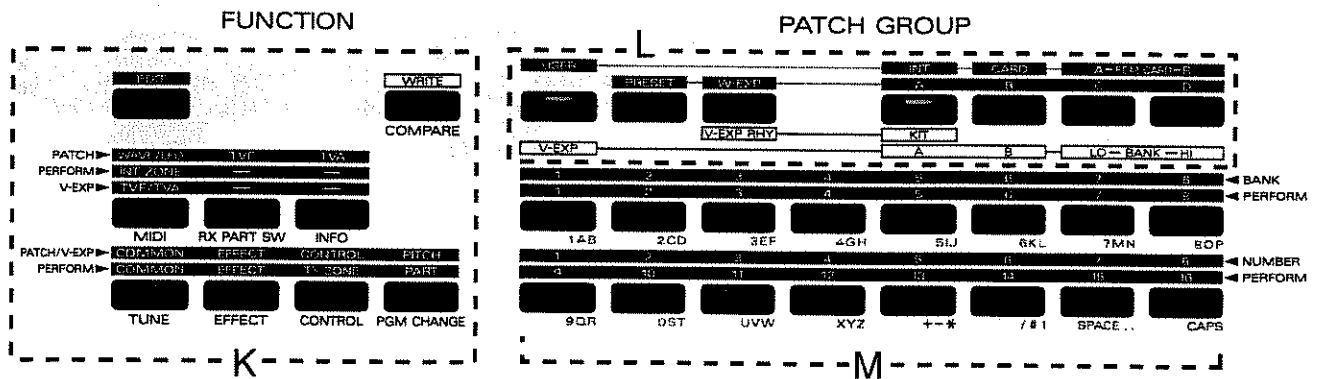

PATCH GROUP

L. Patch Group Buttons
 You can use these buttons together with the Bank and Number buttons (M) to select a sound. The sound group that can be selected with the Patch Group buttons depends on the selected mode.

M. Bank/Number Buttons
 Use these buttons to select a sound or name a Performance or Patch.

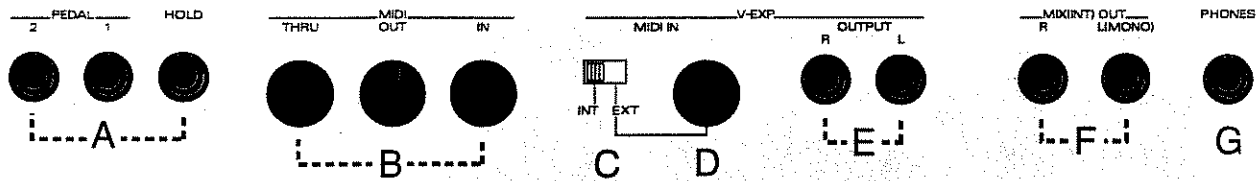

■ Rear Panel

A.

Pedal Jacks 1 and 2

Connect an optional footswitch (e.g. FS-1, DP-2) or expression pedal (EV-5 or EV-10) to these jacks. By assigning the specified function to the connected footswitch or pedal, you can sustain a sound or alter the tone, etc. (See page 54.)

Hold Pedal Jack

Connect an optional footswitch (e.g. FS-1, DP-2) to this jack and you can use it as a hold (sustain) pedal. (See page 54.)

B. MIDI Connectors (IN/OUT/THRU)

These sockets are for establishing MIDI connections with external devices. (See page 42.)

C. V-EXP MIDI IN Selector Switch (INT/EXT)

When using the MIDI IN of the V-EXP, set this switch to the EXT position. When it is set to EXT, however, you cannot play the sounds on the Voice Expansion Board (optional) from the JV-90's keyboard. Normally this switch should be set to INT. (See page 104.)

D. V-EXP MIDI IN Connector

Use this socket for playing the sounds on the Voice Expansion Board (optional) via MIDI. When the V-EXP MIDI IN connector is being used, be sure to set the V-EXP MIDI IN Selector switch to the EXT position. (See page 104.)

E. V-EXP Output Jack (V-EXP OUTPUT)

Sound of the Voice Expansion Board (optional) is output through this jack. When the Voice Expansion Board is not connected to this jack, no sound is output.

F. Output Jacks (MIX(INT) OUT)

Through these jacks, sounds can be output to an amplifier or mixer. When the V-EXP Output jack is not being used, the sound of the JV-90 and that of the Voice Expansion Board (optional) are mixed and sent through the MIX(INT) OUT jack.

G. Headphone Jack

Connect headphones to this jack (Roland RH-20/80/120 (optional)). Even when headphones are used, audio signals are output through the Output Jacks.



H. Power Switch

This switch turns the JV-90 on and off.

I. AC Inlet

Connect the power cable to this inlet.

Versions of this product designed for use with 117V current do not have an AC inlet.

They are instead equipped with a power cord that is permanently attached to the unit.

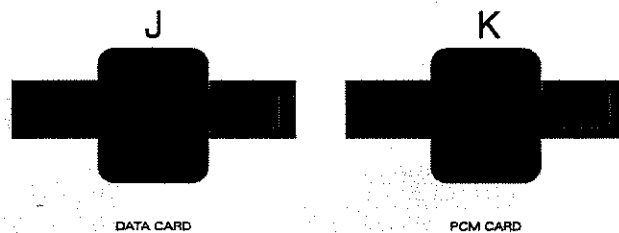

J. DATA Card Slot

Insert an optional DATA card (e.g. M-256E) into this slot.

K. PCM Card Slot

Insert an optional PCM card (SO-PCM1 Series) into this slot.

■ Side Panel

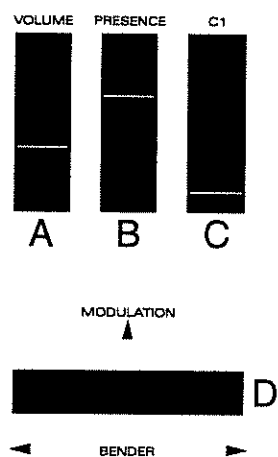

A. Master Volume Slider

This slider controls the overall volume of the JV-90. When the Voice Expansion Board (optional) is used, the volume of the sound output through the V-EXP OUTPUT (L/R) jacks cannot be controlled with this slider.

B. Presence Control

This controls the overall 'brightness' of the sound. Raising the slider will brighten the sound. When the Voice Expansion Board (optional) is used, the sound output from the V-EXP OUTPUT (L/R) jacks is not affected by this control.

C. C1 Slider

You can assign various parameters or functions to this slider and change the way the internal sound module will respond. (See page 41.)

D. Bender/Modulation Lever

Using this lever you can obtain realtime pitch bend or vibrato effects.

Chapter 1

QUICK START

T. QUICK Start

Setup

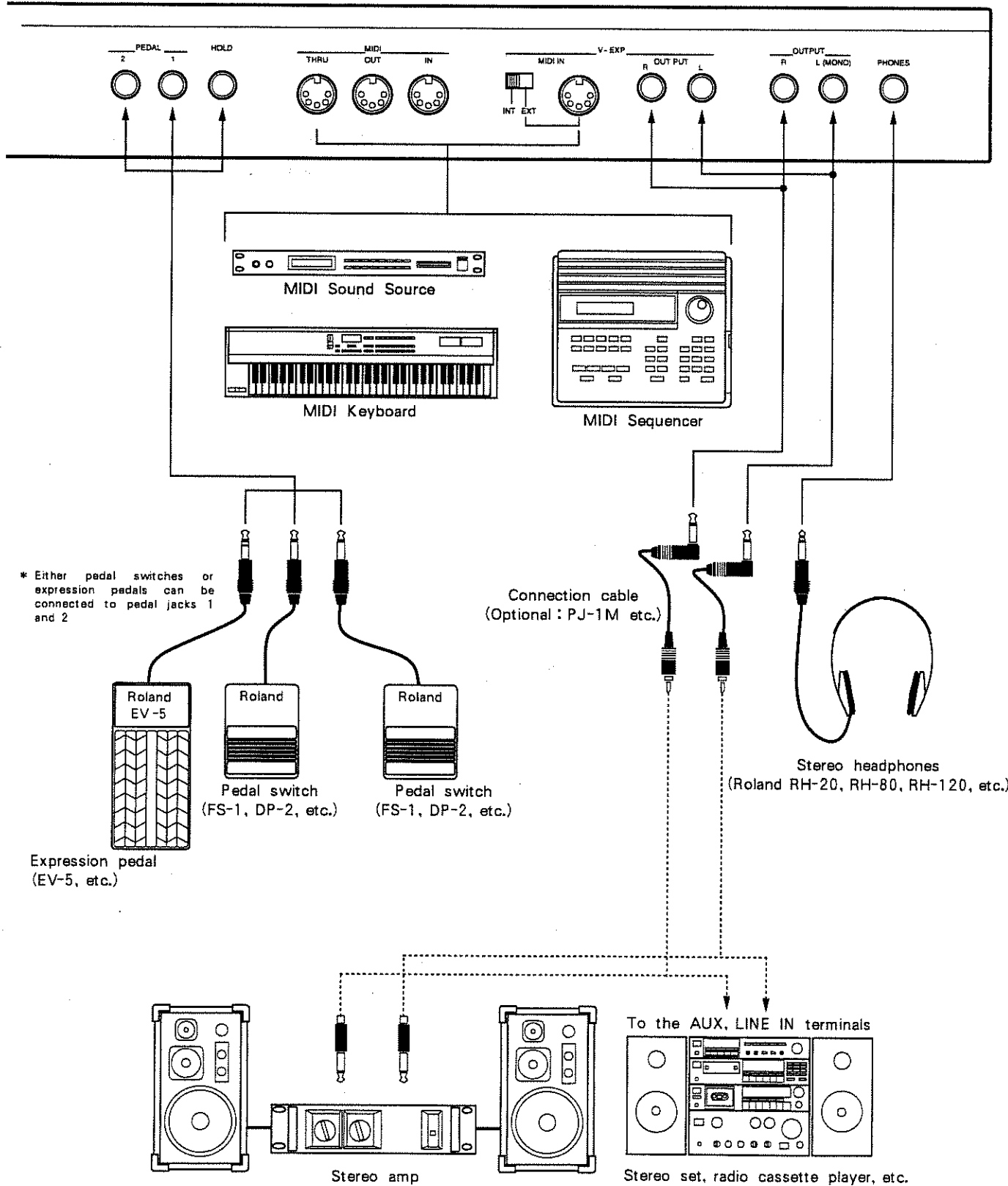

Connect the MIX(INT) OUT jack on the rear of the JV - 90 to an amplifier/speaker setup (stereo set). You can also connect stereo headphones to the PHONES jack.

To achieve the best results, use a stereo output when possible. For stereo use, connect two cables (L and R) to the amplifier. For monaural use, use the JV - 90's L(MONO) jack only.

* You can use the V - EXP OUTPUT jack on the rear of the JV - 90 when a Voice Expansion Board (optional) is installed.

If you connect a pedal switch or expression pedal to the HOLD or PEDAL jack on the rear of the unit, you can sustain (hold) sounds, or control volume and tone using the foot pedal.

* You can connect a pedal switch (switch type) and expression pedal (volume type) to the HOLD and PEDAL jack at the same time.

Be sure to connect the pedal switch (switch type) to the HOLD jack.

■ Power On / Off

● Switching on the JV - 90

1. Check the following points before switching on the JV - 90:
The external units (such as an amplifier) are correctly set up.
The volumes of the JV - 90 and the amplifier are set to minimum.
2. Switch on the JV - 90.
The LCD on the JV - 90 responds with :

```
EXPANDABLE SYNTHESIZER  
Roland JV-90
```

3. Switch on the amplifier and raise the volume to an appropriate level.
 4. Raise the volume of the JV - 90 with the VOLUME knob as you play the keyboard. Then press the [PRESET] and NUMBER buttons in PATCH GROUP to check that the Patch selection function is working properly.
- * The JV - 90 is equipped with a protection circuit. A brief interval (a few seconds) after power up is required before the unit will operate normally.
 - * Take care when setting volume levels; excessive levels can damage equipment and your hearing!

● Switching off the JV - 90

1. Check the following points before switching off the JV - 90:
The volumes of the JV - 90 and the amplifier are set to minimum.
- * Turning off the unit will instantly erase any sounds you have created. To retain this data, save it into memory as shown in "Saving data" on page 88.
2. Switch off the JV - 90.

■ Playing the demonstration songs

1. Press [PATCH] while holding [LEVEL] in the EDIT PALETTE to select the Demo Song mode.

The screen will respond with :

```
ROM  
PLAY                               [Press ENTER/EXIT]
```

2. Press [ENTER], and the JV - 90 starts playing the demonstration songs. To stop playing, press [EXIT].

No.	Title	Song name	Music / Copyright
1	Eldiablo W/EX	1.Eldiablo	Mitsuru Sakaue © 1993, Roland Corporation
2	Ada's Raveola	2.Ada's Raveola	Adrian Scott © 1993, Adrian Scott
3	JV Demo	3.JV Demo	Marvin Sanders © 1993, Marvster Music

3. To exit the Demo Song mode and return to the normal mode, press [EXIT] while no demo song is playing.

- * When the JV - 90 is in the Demo Song mode, the keyboard or panel buttons will not work.
- * No performance data of the demonstration songs is output from MIDI OUT.

● Biographies of Composers

Mitsuru Sakaue

Mitsuru Sakaue began composing and doing arrangements for commercials and videos while still in school.

In particular, his studio work earned for him a solid reputation. Currently, he produces commercial musics and jingles for FM stations.

Adrian Scott

Adrian Scott formerly handled the vocals and keyboards for the popular Australian group, "Air Supply." Since following the solo path, he won the Silver Prize at the "World Song Festival Tokyo '84." Currently, he is involved as a producer of commercial music and music for films. In addition, as a session player, he has performed along with a number of Australia's top musicians, including John Farnham and Kylie Minogue. He lives in Melbourne, Australia.

Marvin Sanders

Marvin Sanders is a somewhat wacky Los Angeles composer whose work can be heard on projects for Toyota, Acura, Max Factor, Alpine, Thomas Brothers, Theater for Young Audiences, and Michael Jackson. He has also worked extensively with Roland, conducting clinics and writing music for numerous product videos and demos including ROM - plays in the SC - 155 and JV - 880.

■ Changing Patches (PATCH Play Mode)

Many different Patches (sounds) have been preprogrammed into the JV - 90. Each Patch is created by setting different values for the various parameters.

1. Press [PATCH] in MODE. The indicator will light and the Patch Play mode has been selected. It is from this point that you select the various Patches.
2. Use the [PRESET], [A], [B], [C] and [D] buttons, and buttons [1]—[8] in PATCH GROUP to select the desired Patch. The screen shows the name of the Patch you have selected. (See the Patch Table on page 127.)

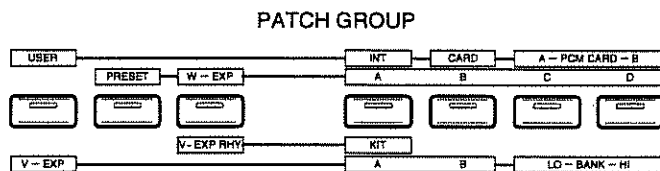

To select a Patch on a card or Expansion Board:

When you use any of the Roland PN - JV80 series cards, insert the card into the DATA CARD slot and press [USER] and [CARD] in the PATCH GROUP (the indicators will light). Press BANK and NUMBER buttons to select a Patch.

When you use any of the Roland SO - PCM series cards, insert the card into the PCM CARD slot and press [USER] and [PCM CARD A] or [PCM CARD B] (the indicators will light). Press BANK and NUMBER to select a Patch.

When you are using any of the Roland Wave Expansion Boards (SR - JV80 series), press [W - EXP], [A], [B], [C], or [D] in PATCH GROUP (the indicators will light). Select the Patch you like using the BANK and NUMBER buttons.

When you are using a Roland Wave Expansion Board (VE - GS1 or VE - JV1), press [V - EXP] in MODE, [V - EXP] in PATCH GROUP (the indicators will light). Select the Patch you like using the BANK and NUMBER buttons. If, however, the INT/ EXT switch on the rear of the unit has been set to the EXT position, no Patch on the Voice Expansion Board can be played from the JV - 90's keyboard. Please read "How to change sounds in a Part" (VE - GS1 P.106 VE - JV1 P.105) in detail of Patch selection.

- * Before inserting a card or installing an Expansion Board, be sure that the JV - 90 is switched off.

■ Altering the sound on the JV - 90

Velocity and Aftertouch

The volume, pitch or timbre (tone quality) of a sound can be altered with the use of keyboard aftertouch. Aftertouch effects are created by applying pressure to the keys after they have been played initially. (See Aftertouch on page 54.)

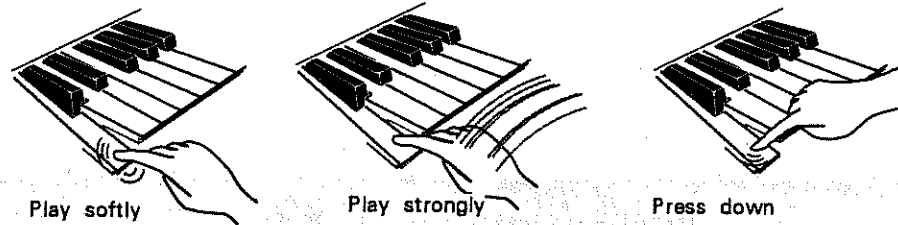

Bender and Modulation Lever

Moving the lever to the left will lower the pitch of the sound, while moving it to the right will raise the pitch. This is called the Pitch Bend effect. Pushing the lever forward (away from you) will create the Pitch Modulation effect. (See page 54.) By moving the lever to the far left or right position and then pushing it forward, you will create both pitch bend and modulation effects at the same time.

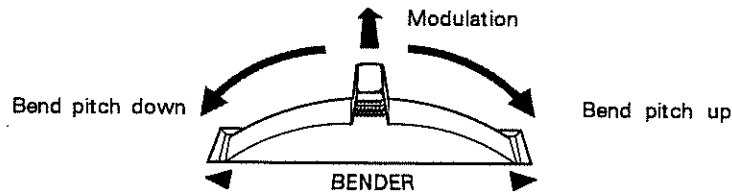

C1 Slider

By raising or lowering this slider, you can change the volume or the quality of the sound. How the sound changes depends on the parameter settings. (See page 41.)

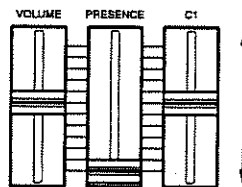

Presence Control

By moving this slider you can change the brilliance of the sound. Raising the slider will brighten the sound.

■ Playing Rhythm sounds (RHYTHM Play Mode)

1. Press [RHYTHM] in MODE (the indicator will light). This selects the Rhythm Play mode that allows you to play various percussion sounds. A different instrument is assigned to each key of the keyboard. (page 131)
- * Some keys do not have sounds assigned to them.
2. Press [PRESET] in PATCH GROUP (the indicator will light), then select a Rhythm Set by pressing [A], [B], [C] or [D]. Sound assignment to the keyboard differs with each Rhythm Set.

■ Mixing different sounds (PERFORMANCE Play Mode)

In the Patch Play mode, you select and play one of the Patches. The Performance Play mode, however, allows you to play more than one Patch at the same time. This combination of Patches is called a Performance. Many different Performances are preprogrammed in the JV - 90.

1. Press [PERFORMANCE] in MODE (the indicator will light). This selects the Performance Play mode that allows you to select any Performance you like.
2. Select a Performance using [PRESET], [A], [B], [C] or [D] and [1]—[16] in PATCH GROUP. The screen shows the name of the Performance you have selected. (page 127)
3. Press [PRESET], [A] and [1] (the indicators will light), and the Performance named "Jazz Split" is selected. This Performance contains a bass sound in the left section of the keyboard and a piano sound in the right section. That is, it simultaneously uses a bass Patch and a piano Patch. You can even find Performances where two Patches are played at the same time by pressing one key.
4. Press [PRESET], [A] and [16] (the indicators will light). The Performance named "PopOrchestra" is selected.

```
PERFORM  | PopOrchestra:      Part Level  
A16      | #112|127|127|117|127|127|127|127
```

5. Pressing [◀]/[▶] will move the cursor and change Patches. You can select 7 Patches and one Rhythm Set.
- * The flashing underline in the display is called the "Cursor".

Using MIDI (page 42), you can automatically play the JV - 90 from a sequencer or computer. This may be useful for ensemble performances with many different sounds.

- * A sequencer is a device which records and plays MIDI data.

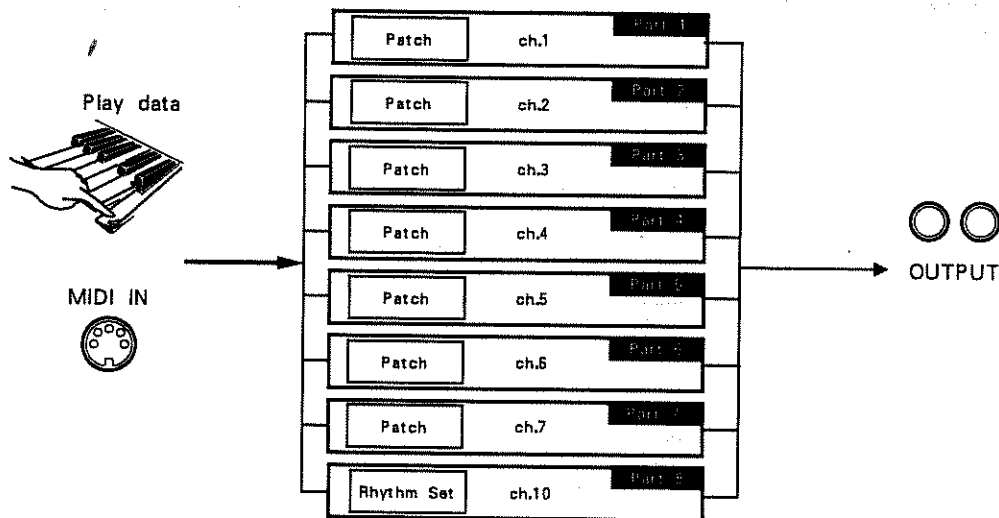

As shown in the figure above, one Patch is assigned to each Part of the ensemble Performance. By changing Patches, you can make an ensemble Performance with the ideal sounds for each Part.

* By installing a Voice Expansion Board, you can increase the number of Parts available. (See page 102.)

6. When the indicator of the [LEVEL] button in EDIT PALETTE is lit, the screen shows the same display as in step 4 above. Pressing PERFORM ► [PATCH] in EDIT PALETTE will then select the following screen.

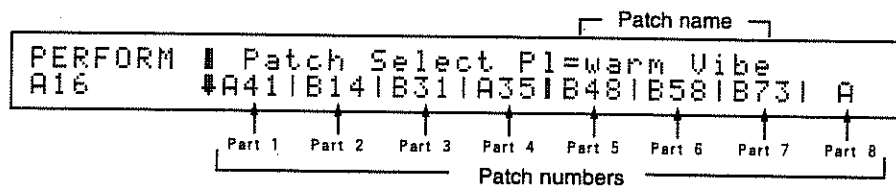

This screen shows the numbers and names of the Patches assigned to the 8 Parts. Move the cursor using [◀]/[▶] to assign a Patch to each Part.

■ Using the three Key Modes (Layer, Zone and Single)

We have referred to three different Play Modes so far; Patch Play, Performance Play and Rhythm Play. The Performance Play mode includes three different Key Modes. The two Performances (Jazz Split and PopOrchestra) introduced on the previous page are played in different ways. This is because Jazz Split is set to the Zone Key mode while PopOrchestra is set to the Single Key mode. The third Key Mode, Layer, can mix two different Patches.

* For a detailed explanation about the Key Modes, see page 67.

■ Creating original sounds (EDIT PALETTE)

A Patch is made from various parameters and consists of some Tones. A Patch on the JV - 90 can include up to 4 Tones. A Tone is made by modifying a Waveform.

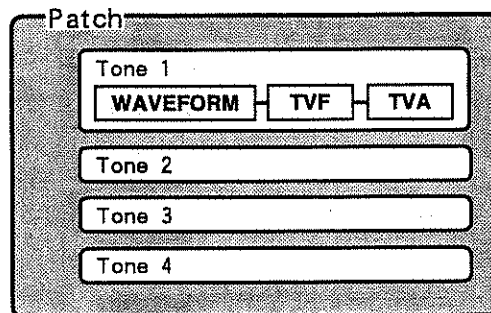

Changing the values of sound parameters of a Patch is called "editing". The following shows a simple editing method.

1. Press [PATCH] in MODE (the indicator will light). The Patch Play mode is selected.
2. Press [PRESET], [A], BANK ► [2] and NUMBER ► [2] (the indicators will light). The Patch named "Stack Major" is selected. This Patch contains 4 Tones.
3. Press buttons [1]—[4] in TONE SWITCH to turn the 4 Tones on or off. Be sure to listen to each of the Tones. The Patch will sound differently by turning the Tones on or off.
4. Make sure to confirm that the indicator on the EDIT PALETTE's [LEVEL] button is lighted. If it is not, press [LEVEL] to turn it on. The screen at this time will show the volume level for each of the Tones. By altering the level for each of the Tones, you can control their relative prominence within mixture. The resulting mixture of differing volume levels will affect the timbre obtained with the Patch.

PATCH	↑Stack Major :	TVA Level
A22	↓ 127 96 113 127	

5. Lighten 4 all TONE SWITCH indicators. Then move the cursor to the desired Tone using [◀]/[▶], then change the volume (TVA Level) of each Tone with [DEC]/[INC]. Pressing [DEC] decreases the value while pressing [INC] increases it. If you hold [DEC] down, the value will change continuously. If you press [INC] while holding [DEC] down, the value will change more rapidly.

6. The volume of each Tone can also be edited by moving the sliders (PARAMETER SLIDERS) 1, 2, 3 and 4 in EDIT PALETTE. If you move the slider while holding [ENTER] down, the cursor will move without the value being changed.
7. Press PATCH ► [WAVE] in EDIT PALETTE (the indicator will light). The screen shows the waveform used in each Tone. Move the cursor and try changing the waveform using the [DEC]/[INC] buttons or Parameter Sliders. (page 126)

```

PATCH  ↑Stack Major : (Ac Piano 1 )Wave
A22      ↓          11      71      91      |

```

Pressing [▼] in this screen will select a sequence of different displays for editing other parameter values. You can experiment with various sound changes by editing the values.

8. Similarly, you can select a different sound parameter display by pressing the relevant button in EDIT PALETTE, and then editing the value. For a detailed explanation about how each parameter affects the sound, below page 55.
- * Sound data you have created here will be erased when the unit is switched off. If you wish to retain this data, save it into memory using the Write procedure described below.

Write Procedure

To retain a sound you have made, store it into memory as explained below.

1. Press [WRITE]/[COMPARE] in FUNCTION.
2. Make sure that the cursor is positioned at Write, then press [ENTER]. If the cursor is not at the Write position, move it using [◀]/[▶].
3. Press [WRITE/COMPARE] again while playing the keyboard. You can hear the new data and the old data that exists at that place and compare them (Compare function). Writing new data will automatically erase the existing sound data. Press [WRITE/COMPARE] again, new data sounds.
4. Specify the number where the data should be written using the BANK and NUMBER buttons. You can also specify the number with the [DEC]/[INC] buttons. We call the place where data is written the "User Area" or "User Bank".
5. Press [ENTER]. If the screen responds as follows, press [DEC] to turn OFF the Write Protect function, then press [ENTER] again. Once more press [ENTER], the screen will respond with the message "Complete" showing that the data has been saved.

```

WRITE   █ Internal █ Exclusive █
PROTECT █         █ ON      █ OFF █

```

- * Write Protect is a function that prevents the accidental erasure of data.
- * To cancel writing, press [EXIT].

■ Note on transmitting MIDI messages from the JV - 90 (INT ZONE, TX ZONE)

Parameters of the JV - 90's keyboard belong to either the Transmit Zone or the Internal Zone.

Some parameters in the Transmit and Internal Zone have the same names so you must be careful not to confuse them.

To control an external MIDI device from the JV - 90's keyboard, you must edit the parameters (see page 70) in the Transmit Zone, such as when you set a transmit channel or specify the range of note numbers to be transmitted.

To control the internal sound module of the JV - 90 with the JV - 90's keyboard, you must edit the parameters in the Internal Zone (see page 73). Parameters in the Internal Zone include the Local Control Switch (see page 75) that can be set separately for each Part. The Part for which this switch is set to OFF will not be played on the JV - 90's keyboard (when the Key Mode (page 67) is set to the Zone or Layer). The internal Zone also includes Master Local Control (page 43). Even when the Local Control is set to ON for a Part, it cannot be played on the JV - 90's keyboard unless the Master Local Control is also set to ON.

When the JV - 90 is set to the Patch mode (page 26), you must set a MIDI transmit or receive channel using the parameters in a Patch. (See page 42.) Setting a MIDI channel here will automatically cancel the previously specified value of the parameter in the Performance (page 43) or Transmit Zone (page 72).

■ If stuck notes occur ... (PANIC)

The following procedure will reset the entire system (including MIDI). Use this procedure to stop "stuck" or "hanging" notes.

● Procedure

While pressing [CUTOFF/TX VOLUME], press [RELEASE/INT TRANS].

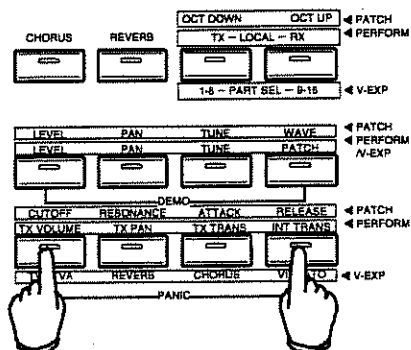

If you press the buttons only for a short time (less than one second), the internal sound source will be muted, and Key Off / Hold Off messages will be transmitted to each channel for which there is a Key On / Hold On. If you press the buttons for more than one second, the following messages will be transmitted to all channels.

All Note Off (note off velocity 127)

Pitch Bender = center

Channel Aftertouch = 0

Modulation = 0

Hold = 10

Volume = 127



Chapter 2

***PERFORMANCE
AND REALTIME EDIT
IN THE PLAY MODE***

1. Patch Play mode

About the Patch Play mode

Patch Play mode is when just a single Patch is called into the temporary area and played. A Patch may consist of up to four Tones, and you can use the parameter sliders and the TONE SWITCH buttons to adjust each Tone in realtime as you play.

By adjusting parameters in realtime you can add expression to your playing, or create effects that are not possible with conventional controllers. This mode allows you maximum expressiveness with a single sound, and is suitable for playing solos, etc.

- * Changes you make with the parameter sliders etc. will affect only the data that has been read into the temporary area. The original Patch data in internal memory (or the DATA card) will not change. If you wish, you can store the modified settings from the temporary area as a Patch in the user memory. (See p.87, Write mode.)

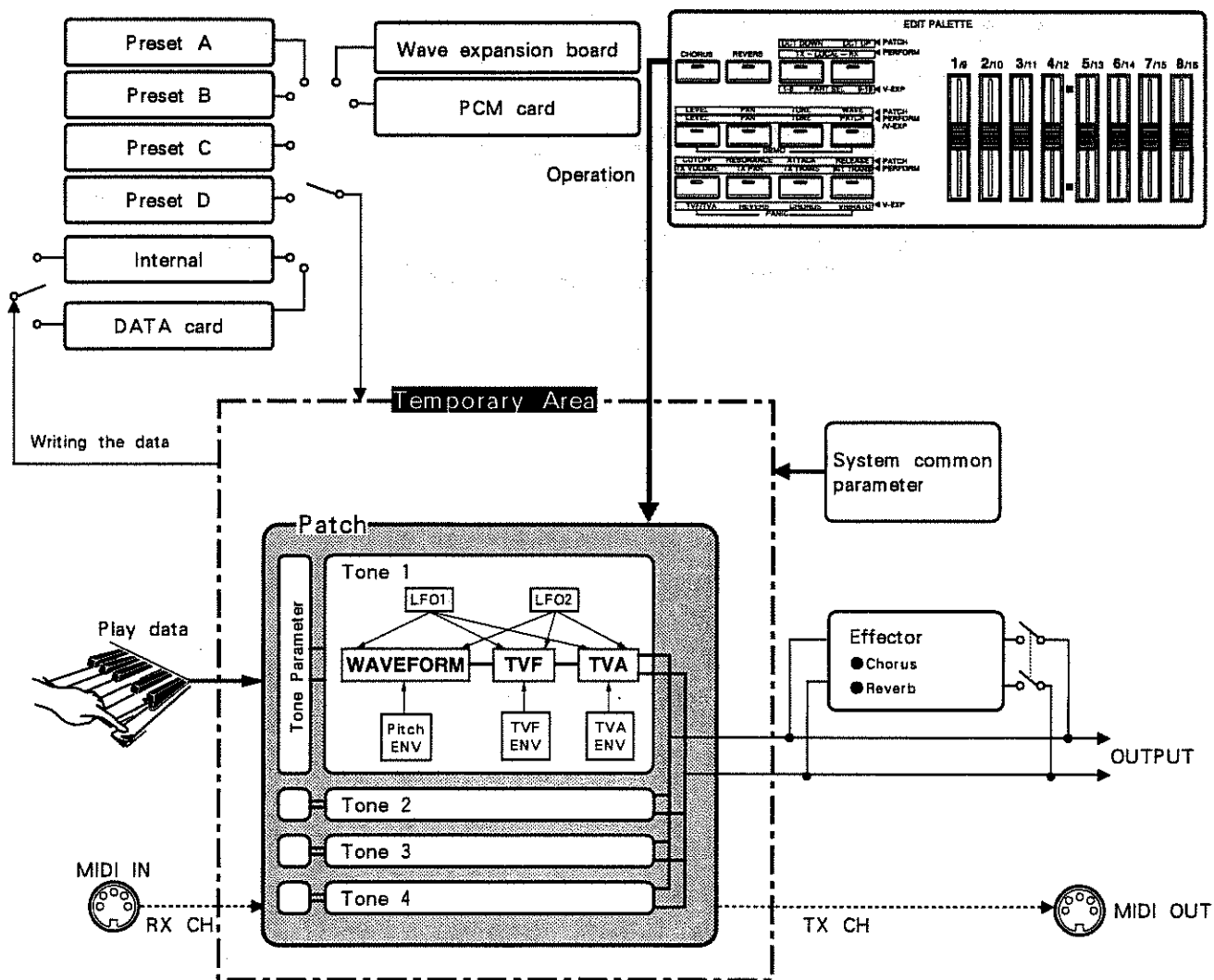

Operation guide

● How to use the TONE SWITCH buttons

You can use the TONE SWITCH buttons ([1]—[4]) to turn the sound on/off for each Tone. This is convenient when you wish to hear only a specific Tone.

- * The button indicator is lit when on.

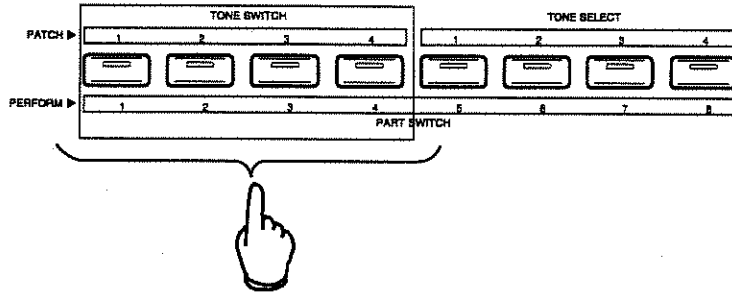

- * The on/off setting you make for each Tone using the TONE SWITCH buttons ([1]—[4]) is stored as part of the Patch settings when you use the Write operation (p.87).

● Use the assign buttons to select parameters

In Patch Play mode, you can press the edit assign buttons to directly select Patch parameters which determine the basic sound of each Tone (pitch, frequency spectrum, volume, and time - varying change and effects).

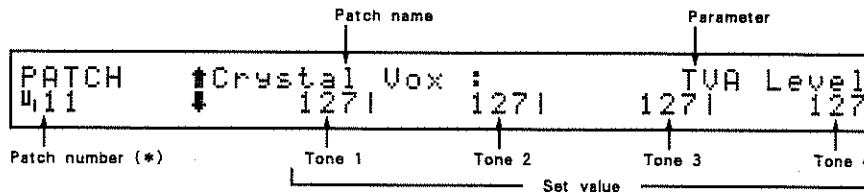

(*) U₁ = internal, U₂ = DATA card, A/B/C/D = preset(group),
 P₁ or P₂ = PCM card, E₁/E₂/E₃/E₄ = wave expansion board, 3 or 4 =JV - 80 compatible preset

The display will show the parameter values for each Tone. Use parameter sliders 1—4 to adjust the values for Tones 1—4.

EDIT PALETTE

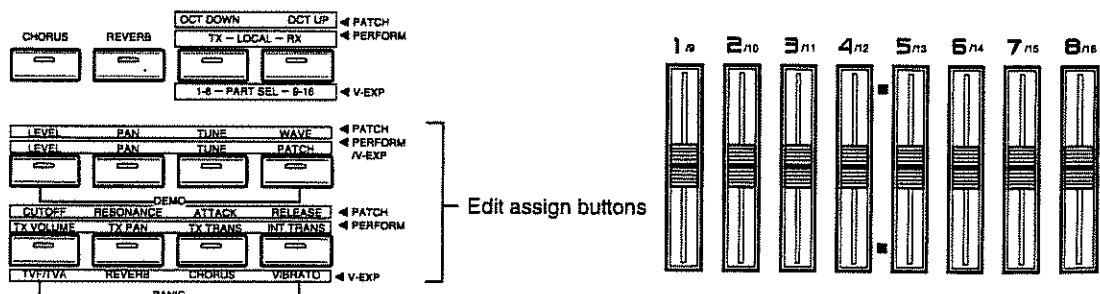

● Parameters you can adjust while in Patch Play mode

In the JV - 90, display screens in which you can modify parameters are called Pages. Each of the assign buttons has several pages assigned to it, and by changing pages you can adjust various parameters in realtime.

When the assign buttons have been pressed, you can use [▲]/[▼] to select the each parameters. You can modify these settings while you play. For details on each parameter, refer to chapter 3 - 1. (p.48)

Edit assign button	Parameter selected by ▲/▼	Corresponding parameter of Patch Edit mode			See Page
		Function select button	Parameter selected by ▲/▼		
LEVEL	▲TVALFO 2 Depth	WAVE/LFO	LFO DEPTH	A1	P.57
	▲TVALFO 1 Depth			A2	P.57
	▲TVAU-Crv	TVA	TVA	Crv	P.62
	▲TVA Velo Sense			Vel	P.62
	TVA Level			Lev	P.62
	▼TVA Key Follow			L - KF	P.62
	▼Tone Delay Time	TVA	DELAY	Time	P.63
	▼Tone Delay Mode			Mode	P.63
PAN	▲Reverb Send	EFFECT	FX SEND	Reverb	P.51
	▲Chorus Send			Chorus	P.51
	▲Dry Level			Dry	P.51
	Pan	TVA	TVA	Pan	P.62
	▼Pan Key Follow			P - KF	P.62
TUNE	▲PitchLFO 2 Depth	WAVE/LFO	LFO DEPTH	P2	P.57
	▲PitchLFO 1 Depth			P1	P.57
	▲Pitch Envelope	PITCH	PITCH	Env	P.58
	Coarse Tune			Crs	P.57
	▼Fine Tune			Fin	P.57
	▼Random Pitch			Rnd	P.57
	▼Pitch Key Follow			P - KF	P.58
WAVE	Wave	WAVE/LFO	WAVE	No	P.55
	▼Wave Group			Group	P.55
	▼FXM Switch	WAVE/LFO	FXM	Switch	P.55
	▼FXM Depth			Depth	P.55

Edit assign button	Parameter selected by ▲/▼	Corresponding parameter of Patch Edit mode			See Page	
		Function select button	Parameter selected by ▲/▼			
CUTOFF	▲TVF LFO 2 Depth	WAVE/LFO	LFO DEPTH	F2	P.57	
	▲TVF LFO 1 Depth			F1	P.57	
	▲TVF-EnvVeloSense	TVF	TVF	TVF - ENV *	Vel	P.61
	▲TVF Envelope			Env	P.60	
	Cutoff			Cut	P.60	
	▼Filter Type			Typ	P.59	
	▼Cutoff Key Follow			F - KF	P.60	
RESO-NANCE	Resonance	TVF	TVF	Res	P.60	
	▼Resonance Mode			Mode	P.60	
ATTACK	▲TVF-EnvKeyFollow	TVF	TVF - ENV *	T - KF	P.61	
	▲TVF Envelope T4			T4	P.61	
	▲TVF Envelope L3			L3	P.61	
	▲TVF Envelope T2			T2	P.61	
	▲TVF Envelope T1			T1	P.61	
	TVA Envelope T1	TVA	TVA - ENV *	T1	P.64	
	▼TVA Envelope T2			T2	P.64	
	▼TVA Envelope L3			L3	P.64	
	▼TVA Envelope T4			T4	P.64	
	▼TVA-EnvKeyFollow			Time - KF	P.64	
RELEASE	▲TVF-EnvKeyFollow	TVF	TVF - ENV *	T - KF	P.61	
	▲TVF Envelope T1			T1	P.61	
	▲TVF Envelope T2			T2	P.61	
	▲TVF Envelope L3			L3	P.61	
	▲TVF Envelope T4			T4	P.61	
	TVA Envelope T4	TVA	TVA - ENV *	T4	P.64	
	▼TVA Envelope L3			L3	P.64	
	▼TVA Envelope T2			T2	P.64	
	▼TVA Envelope T1			T1	P.64	
	▼TVA-EnvKeyFollow			Time - KF	P.64	

Parameter setting displays marked by * occupy two screens in Patch Edit Mode.

-
- * In Patch Play mode, MIDI channels for transmission and reception can be set independently. However, these settings are determined not by the Patch parameters, but rather by the System Common parameters. Thus, the MIDI channels will not change when you select a different Patch. If you wish to change the MIDI channels, modify the System Common parameters (p.42).

In Patch Play mode, it is possible to adjust the same parameter simultaneously for all four Tones. In Patch Edit mode (p.48), which is explained later in this manual, the screen will show several parameters for one Tone, so it may be difficult to keep track of the overall Patch. For this reason, it is effective to use Patch Play mode for Patch editing when you wish to adjust the balance between Tones, since this helps you to remain aware of the overall structure of the Patch.

2. Performance Play mode

About the Performance Play mode

In Performance Play mode you can combine 7 Patches one Rhythm Set to create richer and more complex sounds. Or you can play the various Patches independently to create an ensemble.

Musical data from the keyboard controller and other control data (from the parameter sliders and other controllers) passes through the Internal Zone settings and controls the Patch which has been assigned to each Part. External MIDI devices can be controlled on eight MIDI channels via the Transmit Zone.

- * Changes you make using the parameter sliders etc. affect only the data which has been read into the temporary area. The original performance data in internal memory (or the DATA card) remains unchanged. If you wish, you can save the modified data from the temporary area into user memory as a Performance. (→ Command reference: Write mode)

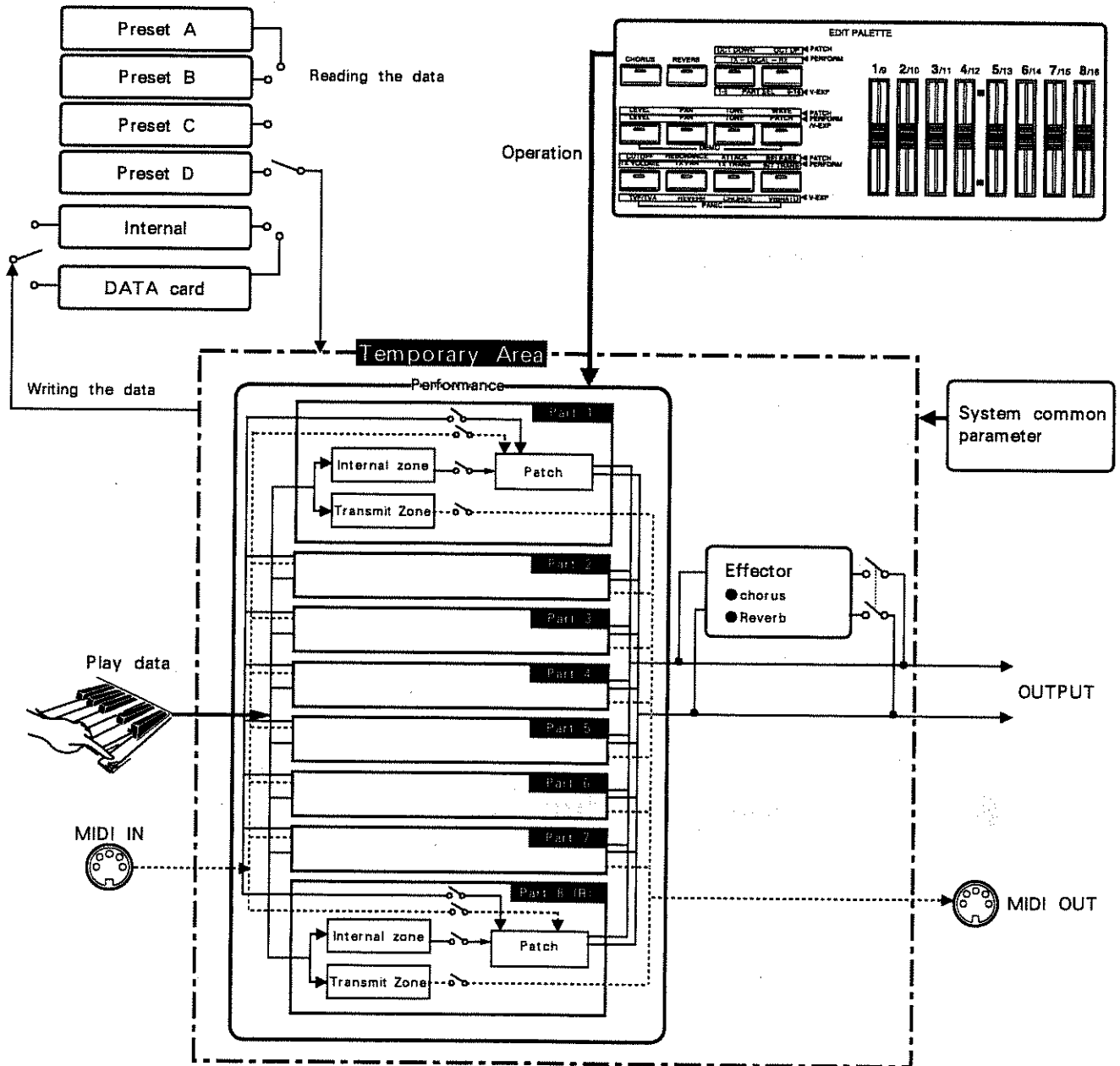

How to use the PART SWITCH buttons

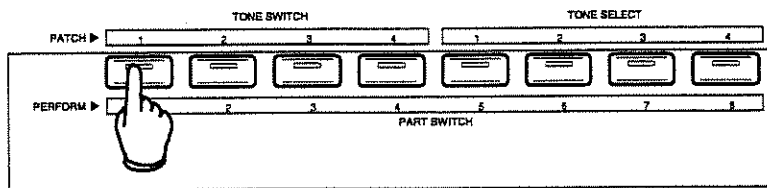

In performance play mode, the PART SWITCH buttons ([1]—[8]) can be used to turn sequencer muting, or the transmit / receive / local switches on / off for each Part. The function of the PART SWITCH buttons depends on the state of the EDIT PALETTE's [TX]/[RX] buttons:

◆ **When [TX] is lit** MIDI transmit switch

Parts which are turned on will transmit musical data from the keyboard etc. from MIDI OUT to external MIDI devices, and Parts which are turned off will not transmit data.

◆ **When [RX] is lit** MIDI receive switch

Parts which are turned on will receive musical data from external MIDI devices connected to MIDI IN, and Parts which are turned off will not receive data.

◆ **When both [TX] and [RX] are lit** Local switch

Parts which are turned on will play their Patch in response to musical data from the keyboard etc., and Parts which are turned off will not play.

- * Settings made using the PART SWITCH ([1]—[8]) and [TX]/[RX] buttons are stored as part of the Performance data when you use the Write operation (p.87).
- * When the Key Mode (p.67) is at SINGLE, settings for the Transmit Switch and Local Switch will be ignored. Only the Transmit Switch and Local Switch for the Part to which the cursor currently points will be turned ON.

The Part Information function

In performance play mode you can press the INFO function select button to see each type of MIDI data which is being received by each Part from MIDI IN. To specify which type of MIDI messages will be displayed, use [▲]/[▼]. The following types of data can be displayed.

```
PERFORM [PART INFORMATION] Modulation
4:01 ↓ 01 01 01 01 01 01 01 0
```

Modulation Modulation 0—127

Messages that control vibrato (pitch modulation) or tremolo (volume modulation)

Volume *Volume* 0—127

Messages that control the volume level

Pan *Pan* L63—0—64R

Messages that control stereo position

Expression *Expression* 0—127

Messages that affect the character of the sound

Hold - 1 *Hold 1* ON/OFF

Hold pedal messages

Aftertouch *Aftertouch* 0—127

Aftertouch messages

Bender *Pitch bend change* -64—+63

Messages that control continuous change in pitch

Voice *the number of voices used* 0—28

The number of currently - sounding voices in the internal sound source (included voices used by playing the JV - 90 keyboard.)

- * The number of voices will vary depending on the number of tones used to form a patch. For every four voices used, " ■ " will appear in the display. " □ " will appear when the total number of voices being used has exceeded 24.
- * The display will show the actual data value of the MIDI message received. The actual result of the message may differ from the displayed data value.
- * The internal synthesizer sound source will not receive the type of MIDI message for which the Receive switch (p.43) has been turned off. Also, Parts whose MIDI Receive switch (p.32) has been turned off will not receive any MIDI messages from MIDI IN.

Parameters accessible from Performance Play mode

Each edit assign button has several parameter pages assigned to it. This section explains the parameter settings for the page that appears when you first press an edit assign button.

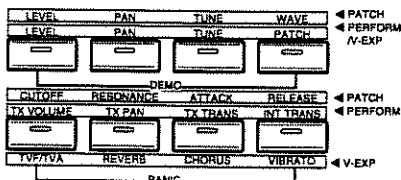

◆ When pressing [LEVEL]

PART LEVEL *Part level* 0 — 127

This parameter sets the level of each Part (relative to the value of the Patch parameter Level). If you do not need to adjust the volume balance between Parts, it is best to set this to the maximum value (127).

◆ When pressing [PAN]

PART PAN *Part pan* L64 — 0 — 63R

This parameter sets the stereo position of each Part.

◆ **When pressing [TUNE]**

Part Coarse Tune Part coarse tune -48—+48

This parameter adjusts the pitch of each Part in semitone steps. Positive (+) values will raise the pitch, and negative (-) values will lower it.

```
PERFORM | Milky Way : Part Coarse Tune
4,01 ↓ 01 01 01 01 01 01 01 0
```

◆ **When pressing [PATCH]**

Patch Select Patch select

This parameter selects the Patch (or Rhythm Set for Part 8) assigned to each Part.

```
PERFORM | Patch Select P1=Crystal Vox
4,01 | 4,11|4,62|4,21|4,36|4,36|4,36|4,17| UI
```

- * Use PATCH GROUP to select the Patch group and BANK/NUMBER to select the bank/number. When you select a Patch, the Patch name will appear in the upper right of the display.
- * It is not possible to select PA/PB or EA —ED Patch groups unless a PCM card is inserted or a wave expansion board is installed.
For some types of boards or cards, not all Patch groups / bank numbers can be selected.

◆ **When pressing [TX VOLUME]**

Transmit Volume Transmit volume 0—127/OFF

These parameters adjust the volume of external MIDI devices.

```
PERFORM | Milky Way : Transmit Volume
4,01 ↓ OFF|OFF|OFF|OFF|OFF|OFF|OFF|OFF
```

◆ **When pressing [TX PAN]**

Transmit Pan Transmit pan L64—0—63R/OFF

These parameters adjust the pan of external MIDI devices.

```
PERFORM | Milky Way : Transmit Pan
4,01 ↓ OFF|OFF|OFF|OFF|OFF|OFF|OFF|OFF
```

- * If you have selected a Performance whose Transmit Volume or Transmit Pan settings are OFF, the display will show "OFF" when you press [TX VOLUME] or [TX PAN]. However, if you then use the parameter sliders or [DEC]/[INC] buttons to modify the setting, you will not be able to re-select "OFF". (P.72)

◆ **When pressing [TX TRANS]**

Transmit Transpose Transmit transpose -36—+36

This parameter transposes the Transmit Zone in semitone steps.

```
PERFORM | Milky Way : Tx. Transpose
4,01 ↓ 01 01 01 01 01 01 01 0
```

- * If the Key Mode is Single (p.67), this setting has no effect.

◆ **When pressing [INT TRANS]**

Int.Transpose Internal transpose -36—+36

This parameter transposes the Internal Zone in semitone steps.

We recommend that you use the Part parameter 'Coarse Tune' to adjust the character of the sound, and use this Transpose parameter to make adjustments for playability.

```

PERFORM 4 Milky Way : Int.Transpose
4,01    ↓ 01 01 01 01 01 01 01 0
    
```

- * The Internal Zone processes the musical data and passes it on to the Part. The sound that actually results will depend on the Patch settings.
- * If the Key Mode is Single (p.67), this setting has no effect.

● **Performance play mode parameter list**

When the assign buttons have been pressed, you can use [▲]/[▼] to select the pages containing the key range or velocity parameters for the Transmit Zone and Internal Zone. You can modify these settings while you play. For details on each parameter, refer to chapter 3 - 2, Performance Edit Mode. (p.65)

Edit assign button	Parameter selected by ▲/▼	Corresponding parameter of Patch Edit mode		See Page
		Function select button	Parameter selected	
LEVEL	Part Level	PART	Level	P.75
	▼ Receive Channel(*)	PART	Receive Channel	P.76
	▼ Voice Reserve(*)		Voice Reserve	P.76
	▼ Chorus Switch(*)		Chorus Switch	P.76
	▼ Reverb Switch(*)		Reverb Switch	P.76
	▼ Receive P.C(*)		Receive Program Change	P.76
	▼ Receive Volume(*)		Receive Volume	P.77
	▼ Receive Hold-1(*)		Receive Hold - 1	P.77
PAN	Part Pan		PART	Pan
TUNE	Part Coarse Tune	PART	Coarse Tune	P.76
	▼ Part Fine Tune		Fine Tune	P.76
PATCH	Patch Select	PART	Patch Select	P.75

Edit assign button	Parameter selected by ▲/▼	Corresponding parameter of Patch Edit mode		See Page
		Function select button	Parameter selected	
Tx VOLUME	▲ TransmitProgramChange	TX ZONE	Transmit Program Change	P.72
	Transmit Volume		Transmit Volume	P.72
	▼ Transmit Channel		Transmit Channel	P.71
TX PAN	▲ TransmitProgramChange	TX ZONE	Transmit Program Change	P.72
	Transmit Pan		Transmit pan	P.72
	▼ Transmit Channel		Transmit Channel	P.71
TX TRANS	▲ Tx.Max Velocity	TX ZONE	Max Velocity	P.71
	▲ Tx.U-Crv		Velocity Curve	P.71
	▲ Tx.Velo Sense		Velocity Sense	P.71
	Transpose	Transpose	P.70	
	▼ Tx.Range Lower	TX ZONE	Key Range Lower	P.70
	▼ Tx.Range Upper		Key Range Upper	P.70
INT TRANS	▲ Int.Max Velocity	INT ZONE	Max Velocity	P.74
	▲ Int.U-Crv		Velocity Curve	P.74
	▲ Int.Velo Sense		Velocity Sense	P.74
	Int.Transpose		Transpose	P.74
	▼ Int.Range Lower		Key Range Lower	P.73
	▼ Int.Range Upper		Key Range Upper	P.73

(*) This parameter can also be accessed by the [PAN] in the Edit assign button.

- * In addition to the parameters listed above, the JV-90 has other parameters which are common to the entire synthesizer sound source (System Common parameters) and are not specific to an individual Performance. Settings of these parameters will not change even when you select a different Performance or enter a different mode. (p.38)

3. Rhythm Play mode

About the Rhythm Play mode

The JV - 90 synthesizer sound source has a Rhythm Set (a set of rhythm sounds) for each memory; internal, preset A B C and D. When you press [RHYTHM] you can play one of these Rhythm Sets from the keyboard controller.

If you are in Performance Play mode when you press [RHYTHM], the Rhythm Set assigned to Part 8 of the Performance will be selected. If you are in Patch Play mode when you press [RHYTHM], the Rhythm Set assigned to Part 8 of the last - selected Performance will be selected.

If you wish to play a different Rhythm Set, use the Patch group buttons to select the desired memory.

When you play the keyboard, the rhythm sound (Rhythm Tone) assigned to that key will sound. The 76 keys from E1 to G7 can be assigned as key numbers.

- * Page 131 lists the Rhythm Tones which were assigned to each key at the factory.
- * Rhythm Sets cannot be played when the Local Switch for PERFORM MIDI (p.43) is OFF.
- * The transmit/receive channels for the Rhythm Play mode will be the same as the transmit/receive channels for Part 8 in the Performance mode.

How to select and modify parameters

In Rhythm Play mode, the display of the synthesizer section will be as follows. The left side of the display will show the note name and key number (Note Number) of the key that was pressed.

```
UI          Switch|Group| No      |
G#2( 44)   |      ON| INT| 95(Closed HAT 2)
```

At this time you can use the parameter sliders, [◀]/[▶] and [INC]/[DEC] to modify the values of the following parameters.

Switch *Tone switch* ON/OFF

This parameter turns the currently selected Rhythm Tone ON (it will sound) or OFF (it will not sound).

Group *Wave group* INT/EXP/CARD

This parameter selects the memory from which the waveform of the Rhythm Tone will be taken: internal (INT), wave expansion board (EXP), or PCM card (CARD).

No *Wave number*

This parameter selects a waveform from the specified wave group. The wave name of the selected number will be displayed in parentheses ().

4. Play mode

System Common parameters

Press [TUNE], [CONTROL], or [MIDI] to access the System Common parameters (parameters common to the entire JV - 90). Here we will explain the System Common parameters relevant to Patch Play mode and Performance Play mode. However, be aware that modifications you make to these parameters will remain even if you select a different Performance or Patch.

● When Pressing [TUNE]

```
TUNE&  | Tune|Transpose|LCD|JV-LEVEL-EX  
FUNCTION|440.0| OFF| 0| 5| 127| 127
```

Tune *Master tune* 427.4—452.6

This determines the overall tuning of the JV - 90. The displayed value is the pitch frequency of the A4 key.

Transpose *Transpose* ON/OFF -36—+36

This transposes the entire JV - 90 in semitone steps. The setting to the left of the " | " determines whether transpose will be used (ON) or not (OFF). The setting to the right of the " | " specifies the amount of transposition.

LCD *LCD contrast* 0—10

This adjusts the contrast (brightness) of the display.

JV - LEVEL *JV Level* 0—127

This adjusts the output level of the internal sound source.

EX - LEVEL *EXP Level* 0—127

This adjusts the output level of the Voice Expansion Board. The value you set here will be invalid if the V - EXP MIDI IN Selector on the rear of the JV - 90 is set to EXT.

```
TUNE&  | Scale Tune| PowerUp|  
FUNCTION| OFF| DEFAULT|-----|-----
```

Scale Tune *Scale Tune Switch* ON/OFF

Tune it ON to use the scale tune feature, and OFF when it is not to be used.

PowerUp *Power up mode* LASTSET/DEFAULT

This specifies the condition the JV - 90 will be in when power is turned on.

LASTSET : The Patch or Performance last selected when the power was turned off will be selected.

DEFAULT : Patch U111 or Performance U101 will be selected.

The pages below are used for making the setting for Scale Tune. The particular page that appears will be different depending on the mode.

● **The Scale Tune Feature**

The scale Tune feature allows you to finely adjust the individual pitch of the notes from C through B. Through the settings are made while working with one octave, the fine adjustments will affect all octaves. By making the appropriate Scale Tune settings, you can obtain a complete variety of tuning methods other than equal temperament.

○ **Equal Temperament**

This method of tuning divides the octave into 12 equal parts. It is currently the most widely used form of tuning, especially in occidental music. On the JV - 90, equal temperament is used whenever Scale Tune is OFF.

○ **Just Temperament (Keytone C)**

The three main chords resound much more beautifully than with equal temperament, but this benefit can only be obtained in one key. If transposed, the chords tend to become ambiguous. The example given involves settings for a key in which C is the keynote.

○ **Arabian Scale**

E and B are a half of a semitone lower than equal temperament, whereas C#, F#, and G# are a half of a semitone higher in this method of tuning. The intervals G-B, C-E, F-G#, A#-C#, D#-F# are a neutral third (interval between a major third and a minor third). On the JV - 90, the Arabian Scale can be enjoyed with the three keys of G, C, and F.

[Example Settings]

Note	Equal Temperament	Just Temperament (Keytone C)	Arabian Scale
C	0	0	-6
C#	0	-8	+45
D	0	+4	-2
D#	0	+16	-12
E	0	-14	-51
F	0	-2	-8
F#	0	-10	+43
G	0	+2	-4
G#	0	+14	+47
A	0	-16	0
A#	0	+14	-10
B	0	-12	-49

● When Pressing [CONTROL]

These settings determine the parameters which will be controlled by foot pedals connected to pedal jacks 1 and 2 and by the C1 slider.

```

PEDAL1  | Model | Assign | (Val: 0)
ASSIGN  | ↓ I+M | CC7/  | VOLUME |----|----
  
```

Mode *Output mode* OFF/INT/MIDI/I+M

This setting determines the destination of the control messages sent by the pedals or the C1 slider. When INT is selected, the messages will be sent only to the internal sound source. When MIDI is selected, the messages will be sent only to MIDI OUT. When I+M is selected, the messages will be sent to both the internal sound source and to MIDI OUT. When OFF is selected, the pedals and the C1 slider will not transmit any messages.

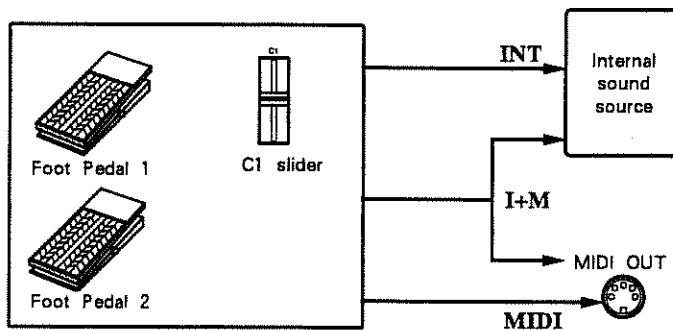

Assign *Assign* CC0 — CC95/AFTERTOUCH/BEND - UP/BEND - DOWN/PROG - UP/PROG - DOWN

These settings determine the parameters which will be controlled by the pedal or C1 slider. CC0—CC95 are control change numbers 0 - 95. BEND - UP / BEND - DOWN indicates pitch bend up and down. PROG - UP / PROG - DOWN will select the next higher or lower Performance or Patch. The value in parentheses () indicates the current position of the pedal or C1 slider.

PEDAL POLARITY pages

```

PEDAL  | Pedal1 | Pedal2 | Hold |
POLARITY | STANDARD | STANDARD | STANDARD |----
  
```

PEDAL1 **PEDAL2** **HOLD** STANDARD/REVERSE

These settings allow the polarity of pedal switches connected to the pedal jacks 1/2 or the hold pedal jack to be reversed so as to be compatible with the JV - 90. When using a Roland pedal switch (DP - 2) set this to STANDARD.

If you are using a reverse - polarity pedal switch made by another manufacturer (e.g., if the sound is held even when the pedal switch connected to the Hold Pedal jack is not pressed), set this to REVERSE.

AFTER TOUCH page

```
AFTER  ↑ Thresh|-----|-----|-----
TOUCH  ↓      |-----|-----|-----
        10|-----|-----|-----
```

Thresh *Threshold* 0—127

This sets the level (threshold level) at which aftertouch will begin to function. If the aftertouch value does not reach this level, aftertouch will have no effect. If this Threshold setting is set to 127, aftertouch will not function at all.

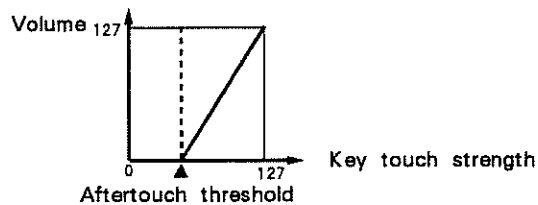

● When Pressing [MIDI]

For some types of board or card, not all Patch groups / bank numbers can be selected.

[When in Patch Play mode]

```
PATCH  ↓ Local| Rx-Ch| Tx-Ch|
MIDI   ↓  ON|   1|  Rx-Ch|-----
```

Local *Local switch* ON/OFF

The internal sound source will produce sound in response to musical data from the JV - 90 itself when this is ON, and will ignore such data when this is OFF. This setting does not affect MIDI transmission or reception.

Rx - Ch *Patch receive channel* 1—16

This sets the receive channel for Patch Play mode.

Tx - Ch *Patch transmit channel* 1—16/Rx - Ch/OFF

This sets the transmit channel for Patch Play mode. When this parameter is set to "Rx - Ch", the transmit channel will be the same as the receive channel. When this is set OFF, data will not be transmitted.

[When in Performance Play mode]

```

PERFORM | Local | Ctrl-Ch |
MIDI    | ON  | 16 |-----|-----
  
```

Local Local switch ON/OFF

The internal sound source will produce sound in response to musical data from the JV - 90 itself when this is ON, and will ignore such data when this is OFF. This setting does not affect MIDI transmission or reception.

Ctrl-Ch Control channel 1—16/OFF

This setting specifies the channel on which Performances will be selected. (This is separate from (and in addition to) the transmit/receive channels for each Part in the Performance.) If this setting is the same as the receive channel setting for one of the Parts in the Performance, Performance selection will take priority. When this is set OFF, transmission/reception will take place.

* The MIDI transmit/receive channels for each Part are determined by the Performance parameters.

TRANSMIT MIDI, RECEIVE MIDI pages

```

RECEIVE | P.C | Bnk | C.C | Vol | Bend | Mod | Aft |
MIDI    | ON | ON  | ON  | ON  | ON  | ON  | ON  | --
  
```

P.C **Bnk** **C.C** **Vol** **Bend** **Mod** **Aft** ON/OFF

These settings specify whether each type of MIDI message will (ON) or will not (OFF) be transmitted/received. The various types of message are abbreviated as follows.

<i>P.C</i>	<i>Program change</i>	<i>Bend</i>	<i>Pitch bender</i>
<i>Bnk</i>	<i>Bank select</i>	<i>Mod</i>	<i>Modulation</i>
<i>C.C</i>	<i>Control change</i>	<i>Aft</i>	<i>Aftertouch</i>
<i>Vol</i>	<i>Volume</i>		

SYS - EX MIDI page

```
SYS-EX  ↑Receive|Dev. ID| |
MIDI    |  ON|  17|-----|-----
```

Receive Exclusive receive switch ON/OFF

This setting turns on/off reception of MIDI data specific to the JV - 90 (such as Performance or Patch data).

Dev. ID Device ID number 17—32

When you wish to transmit or receive exclusive messages, set this parameter to match the device ID number of the other MIDI device.

● RX PART SWITCH

This selects whether or not to recognize the MIDI messages received through MIDI IN for each Part in JV - 90's internal sound module or Voice Expansion Board. Move the cursor with [◀]/[▶] to select a Part, then select 1 or 0 with [INC]/[DEC] (1 is to recognize and 0 is to ignore). The Part where 0 is set will be muted.

- * When the JV - 90 is set to the Performance Mode, changing the value also changes the MIDI Receive Switch (Page 32) automatically.
- * When the JV - 90 is set to the Patch mode, the Part of the Voice Expansion Board (Page 108) that has the same receive channel as the receive channel (Page 42) of the Patch is shown with an arrow " ↓ ".
- * When the V - EXP MIDI IN Selector Switch is set to EXT, the Voice Expansion Board will be played with the MIDI messages received on the V - EXP MIDI IN. The MIDI messages received through MIDI IN, however, will be ignored by the Voice Expansion Board. (Page 104)

■ Effect parameters

These parameters determine effect unit settings (chorus/reverb) for the currently selected Patch or Performance.

- * In Rhythm Play mode, the following operations are not possible.

● When Pressing [EFFECT]

In Patch Play mode, these settings modify Patch effect parameters. In Performance Play mode, these settings modify Performance effect parameters.

PATCH	Chorate	Depth	Rev-Lev	Time
EFFECTS	20	20	100	80

ChoRate *Chorus rate* 0—127

This parameter sets the modulation speed for the chorus effect.

Depth *Chorus depth* 0—127

This parameter sets the modulation depth for the chorus effect.

Rev - Lev *Reverb level* 0—127

This parameter sets the volume of the reverb.

Time *Reverb time* 0—127

This parameter sets the reverberation time.

- * When using chorus/reverb, press [CHORUS]/[REVERB] to turn the effect on.

■ Transmit a Program Change message

Here you can specify a program change message to be transmitted directly.

● When Pressing [PGM CHANGE]

TRANSMIT P.C page

```
TRANSMIT | Tx-Ch | P.C-No | Bnk-MSB | Bnk-LSB
P.C      |      |      |      |      |
          |      | 11001/A11 |      | 01 | 0
```

Tx-Ch *Transmit channel* 1—16

This parameter determines the MIDI channel on which Program Change messages will be transmitted.

P.C-No *Program change number* 001/A11—128/B88

Specify the program change that will be transmitted on the Tx - Ch.

The display will show the number in the format of "program change number / group - bank - number.

The PATCH GROUP / BANK / NUMBER indicators will light to show the selected program change number.

Press [ENTER] to transmit the program change message.

- * When the cursor is located at the program change number display, you can directly enter a number from 001 — 128. The BANK [1]—[8] buttons will enter the numerals 1 — 8, and the NUMBER [1]/[2] buttons will enter the numerals 9/0. Input the desired program change number, and press [ENTER] to transmit the program change message.

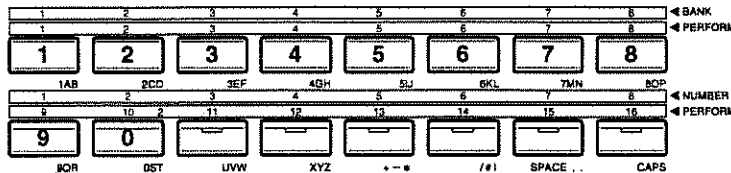

When the cursor is located at the group/bank/number display, you can use the PATCH GROUP / BANK / NUMBER buttons to specify the program change number.

Bnk - MSB/Bnk - LSB *Bank select number* each 0—127

Specify the MSB (control change #0) and LSB (control change #32) of the Bank Select message to be transmitted from the Tx - Ch.

- * The Bank Select message will be transmitted at the same time that the Program Change message is transmitted.
- * For information on the correspondence between the JV - 90's Patch Groups (Media) and Program Change and Bank Select numbers, refer to the "MIDI Implementation"(p.136).

Chapter 3

***DETAILS
OF THE EDIT
OPERATIONS***

Chapter 3

1. Patch Edit mode

About the Patch Edit mode

Each Patch is made up of four Tones. Each Tone has various Tone parameters which determine the character of the sound (pitch, frequency spectrum, loudness, and how these factors change). Tone parameters for the four Tones, a Patch name, and effect unit settings used in Patch Play mode are collectively called "Patch parameters". The process of modifying Patch parameter settings is called "Patch editing".

The sound produced by each Tone passes through several stages to create the final result, and function select buttons have been assigned to access the parameters for each of these stages.

Operation guide

Patch editing procedure

In Patch Play mode, select the Patch you wish to edit. Then press [EDIT] to enter Patch Edit mode. Then press one of the function select buttons to select the desired Patch parameter.

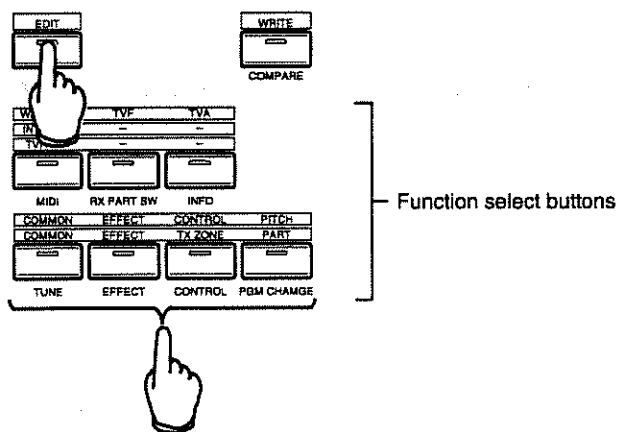

In Patch Edit mode, the following type of pages will appear in the display.

[Example]

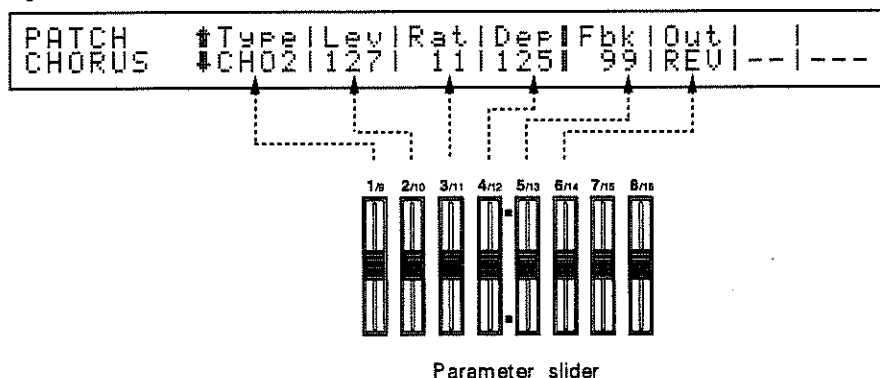

The values from left to right correspond to parameter sliders 1—8. Move the parameter slider (or [DEC]/[INC]) corresponding to the parameter you wish to modify (p.6).

For pages in which "▲" or "▼" is displayed, you can use [▲]/[▼] to select other pages (p.7).

● How to use the TONE SELECT buttons

The TONE SELECT buttons are used in Patch Edit mode. For parameters which can be set individually for each Tone (1 - 4), the display will indicate (for example) "1 - - -". This display indicates the number of the Tone which is currently selected. Use the TONE SELECT ([1] - [4]) buttons to select the Tone to display and edit.

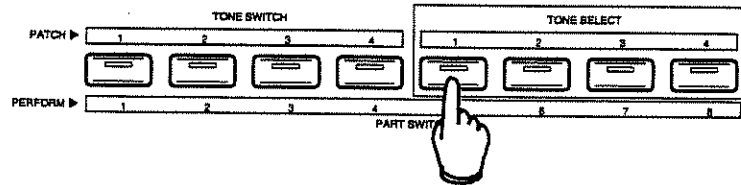

You can also press two or more TONE SELECT buttons simultaneously. The display will indicate the number of the last - selected Tone, and other selected Tones will be indicated by " * ". In this condition, further adjustments you make to a parameter will set the same value for all selected Tones.

■ About the parameters

In this section we will explain the main parameters for each button, and how the parameters work. Press a function select button, and then use [▲]/[▼] to select pages.

● Parameters accessed by pressing [COMMON]

Here you can make settings for parameters that are common to the entire Patch.

PATCH NAME page

Patch name space, A—Z, a—z, 1—9, 0, + - * / # | , .

You can give a 12 - character name to the Patch you are editing. Use parameter slider 2 or [◀]/[▶] to move the cursor, and use parameter slider 1 or [INC]/[DEC] to select a character at the cursor location.

Characters can also be selected using the BANK/NUMBER buttons. (Characters and symbols are printed in grey on the lower right of the buttons.)

The three characters or symbols will alternate each time you press the button.

CAPS : This button switches between uppercase and lowercase letters. When the indicator is lit, uppercase letters will be selected.

SPACE: This button enters a space.

PATCH COMMON page

Level Patch level 0—127

This parameter sets the level (volume) of the Patch.

Pan Patch pan L64—0—63R

This parameter sets the pan position.

Velo - Sw Velocity range switch ON/OFF

The velocity range setting will be valid when this is ON.

VELOCITY RANGE page

Tone 1 **Tone 2** **Tone 3** **Tone 4** each 0—127

These parameters set the velocity range (lower/upper) for each Tone. Lower range is displayed at left, and the upper range at right. The velocity values surrounded by the lower and upper settings are the Velocity Range.

The velocities in its specified range is valid.

* It is not possible to set the Lower value above the Upper.

● Parameters accessed by pressing [EFFECT]

These parameters determine the settings of the built - in effects unit when a Patch is selected in Patch Play mode. The effect settings apply to the entire Patch. The effects unit provides a wide range of possibilities, from deepening and enriching the sound, to radical transformations of the tonal character.

* In Performance Play mode, the effects unit will use the settings of the Performance.

FX SEND (effect send) page

Dry *Dry level* 0—127

This parameter sets the level of the dry (unprocessed) sound.

Chorus *Chorus send level* 0—127

This parameter sets the level of the signal sent to the chorus.

Reverb *Reverb send level* 0—127

This parameter sets the level of the signal sent to the reverb.

PATCH CHORUS page

Type *Chorus type* CHO1—3

This parameter selects the type of chorus effect.

CHO1	A conventional chorus.
CHO2	A chorus with slower rate. You can also apply feedback to use this as a flanger.
CHO3	A chorus with greater depth. An effect of extreme detuning can be produced.

Lev *Chorus level* 0—127

This parameter sets the level of the chorused sound.

Rat *Chorus rate* 0—127

This parameter sets the modulation speed of the chorus effect.

Dep *Chorus depth* 0—127

This parameter sets the modulation depth of the chorus effect.

Fbk *Chorus feedback* 0—127

This parameter sets the level at which sound is fed back into the chorus effect.

* Excessively high settings of Fbk can distort the sound.

Out *Output switch* MIX/REV

This parameter determines the output destination of the chorused sound. When MIX is selected, the chorus sound and the reverb sound will be mixed with the dry signal. When REV is selected, the chorus sound will be sent through the reverb and then mixed with the dry signal.

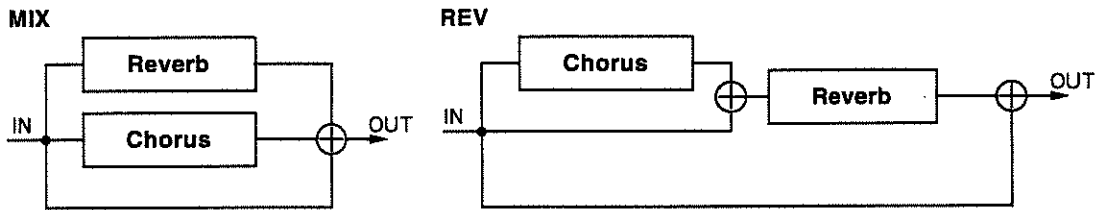

PATCH REVERB page

Type *Reverb type* ROOM1 — 2/STAGE1 — 2/HALL1 — 2/DELAY/PAN - DLY

This parameter selects the type of reverb.

ROOM1	short reverb with dense reverberation
ROOM2	short reverb with sparse reverberation
STAGE1	reverb with more late reverberation
STAGE2	reverb with strong early reflections
HALL1	clear reverb
HALL2	rich reverb
DELAY	conventional delay
PAN - DLY	delay with echoes panned left/right

Level *Reverb level* 0—127

This parameter sets the level of the reverb sound. Higher values will result in a louder level.

Time *Reverb time* 0—127

If Reverb Type has been set to ROOM1 — HALL2, this parameter determines the length of the reverb. If Reverb Type has been set to DELAY/PAN - DLY, this parameter determines the delay time.

F - Back *Delay feedback* 0—127

If Reverb Type has been set to DELAY, this parameter determines the level at which the delayed sound will be fed back into the delay.

ANALOG FEEL page

Depth *Depth* 0—127

This parameter sets the depth of the Analog Feel effect, which applies “1/f modulation” to level and pitch to give greater “naturalness” to the sound (ie., make it sound less digital). Higher settings will result in more modulation.

● Parameters accessed by pressing [CONTROL]

Here you can make settings for the JV - 90 keyboard and controllers.

KEY ASGN & BEND RANGE (Key Assign & Bend Range) page

Assign Assign mode POLY/SOLO

This parameter determines whether the Patch will be polyphonic (POLY) or monophonic (SOLO). If POLY is selected you can play chords, and if SOLO is selected, only the last - played note will sound.

Legato Legato ON/OFF

This parameter determines whether the Legato function will be applied (ON) or not (OFF). Even if Legato is ON, it will not function if the Assign Mode is POLY.

Legato : The envelopes and LFO of the previous note continue. This allows you to simulate the hammer - on/pull - off playing technique of a guitarist.

Bender - Range Bender range -48—0 (down) / 0—12 (up)

Bend Range Down determines how far (in semitone steps) the pitch will fall when the bender lever is moved to the left. Bend Range Up determines how far the pitch will rise when the bender lever is moved to the right.

PORTAMENTO page

Portamento: Portamento is an effect in which the pitch changes smoothly between notes. In Solo mode, it is appropriate to apply Portamento to guitar and wind instrument sounds.

Switch Portamento switch ON/OFF

This determines whether portamento will be applied (ON) or not (OFF).

Mode Portamento mode LEGATO/NORMAL

This determines how the portamento effect will be applied. When NORMAL is selected, portamento will always be applied. When LEGATO is selected, portamento will be applied only to notes played in legato style (i.e., when you play a note before releasing the previous note).

Type Portamento time TIME/RATE

This determines the type of the portamento effect. When TIME is selected, the pitch will move to the new pitch over a specific time regardless of how far apart the two pitches are. When RATE is selected, the pitch will move to the new pitch at a specific rate, so that it will take longer to reach a more distant pitch.

Time Portamento time 0—127

This determines the time over which the pitch will move to the new pitch.

PEDALS page

Volume Volume control switch ON/OFF

This determines whether MIDI Volume messages will be received by the Tone (ON) or not (OFF).

Hold - 1 *Hold 1 Control Switch* ON/OFF

This parameter determines whether Hold 1 (sustain) messages from HOLD / PEDAL1 / PEDAL2 / C1 slider will (ON) or will not (OFF) affect the Tone.

Re - Damp *Re - damp switch* ON/OFF

If a Hold 1 message is received after key - off while notes are still sounding, this parameter determines whether the sound at that time will be held (ON) or not (OFF).

- * If Hold - 1 is OFF, Re - Damp will have no effect even if it is turned ON.
- * The MIDI specification defines control change #7 as volume and control change #64 as Hold 1.

CONTROL page**Modulation** *Modulation control*

You can specify up to 4 Tone parameters to be controlled by modulation messages.

Aftertouch *Aftertouch control*

You can specify up to 4 Tone parameters to be controlled by aftertouch.

Expression *Expression control*

You can specify up to 4 Tone parameters to be controlled by an expression pedal.

The Tone parameters that can be controlled and the ranges of control are given below.

Destination (parameter to be controlled)		Depth (setting range)	Remarks
Display	Meaning		
PCH	pitch (semitone)	-63 — +63	The parameter will increase (rise) for positive (+) values, and decrease (fall) for negative (-) values
CUT	cutoff frequency	-63 — +63	
RES	resonance	-63 — +63	
LEV	level (volume)	-63 — +63	
PL1	depth of LFO 1 applied to pitch	-63 — +63	Positive (+) and negative (-) values invert the phase of the LFO. In either case, values diverging from 0 will have an increasingly greater effect.
PL2	depth of LFO 2 applied to pitch	-63 — +63	
FL1	depth of LFO 1 applied to cutoff	-63 — +63	
FL2	depth of LFO 2 applied to cutoff	-63 — +63	
AL1	depth of LFO 1 applied to volume	-63 — +63	
AL2	depth of LFO 2 applied to volume	-63 — +63	
L1R	rate of LFO 1	-63 — +63	With positive (+) values the LFO cycle will be shortened, and with negative (-) values the cycle will be lengthened. (See diagram
L2R	rate of LFO 2	-63 — +63	

- * The MIDI specification defines Expression as control change #11 and Modulation as control change #1. The JV - 90 transmits Modulation messages when you move the bender/modulation lever away from you. Pedal 1, pedal 2 and the C1 slider will each transmit the MIDI message that has been assigned to them. For details refer to the MIDI implementation chart.

● Parameters accessed by pressing [WAVE/LFO]

These parameters select the waveform (the basic element of sound) and determine the LFO settings.

WAVE page

Switch *Tone switch* ON/OFF

This parameter determines whether the currently selected Tone will be used (ON) or not used (OFF). Voices will be used only by Tones for which this parameter is turned ON.

Group *Wave group* INT/EXP/CARD

This parameter determines which memory the waveform will be taken from. The JV - 90 has 152 waveforms in internal memory (INT). In addition, you can also use waveforms from optional wave expansion boards (EXP) or PCM cards (PCM).

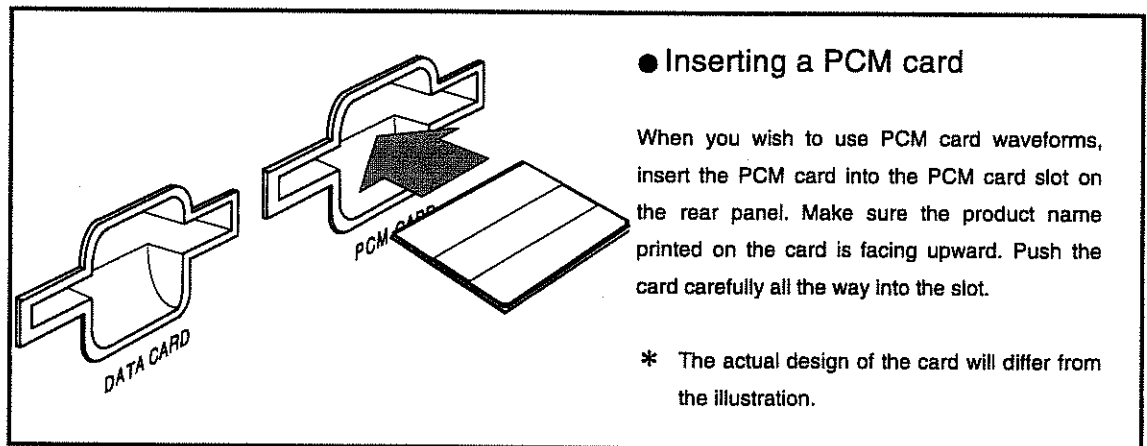

No *Wave number*

This parameter determines the waveform number.

* The display will show only the memory numbers which can be read.

FXM page

FXM modulates the waveform by a different waveform (i.e., applies cross - modulation) to create a new waveform.

Switch *FXM (Frequency X - Modulation) switch* ON/OFF

This parameter determines whether FXM (Frequency Cross Modulation) will be used (ON) or not used (OFF).

Depth *FXM depth* 1 — 16

This parameter determines the depth of FXM.

LFO 1/2 page

The following four pages contain the settings for LFO 1 and 2. (The parameters are the same for both LFOs.)

Form LFO waveform TRI/SIN/SAW/SQR/RND1—2

You can select from the following LFO waveforms: triangle, sine, sawtooth, square, random 1, and random 2.

Synchro LFO synchronization ON/OFF

When this parameter is turned ON, the LFO phase will be synchronized with the key - on timing, so that the phase of each LFO will be independent for each note. When this is turned OFF, the LFO phase will be the same for all sounding Patches.

Rate LFO rate 0—127

This parameter determines the speed of the LFO.

Offset Offset -100/-50/0/+50/+100

This parameter offsets the waveform of the LFO in a positive (+) or negative (-) direction. If a positive (negative) offset is applied to pitch (volume) modulation, the center pitch (volume) of the modulation will be above (below) the normal pitch (volume).

Delay LFO delay time 0—127/KEY - OFF

This parameter sets the length of the delay after the tone begins sounding (key - on) until when the LFO begins to take effect. If this parameter is set to KEY - OFF, the LFO will begin to take effect when the key is released (key - off).

Fade LFO fade mode IN/OUT

This parameter determines how the LFO will be applied over time. When IN is selected, the LFO will gradually increase after key - on, according to the LFO fade time parameter (see below). When OUT is selected, the LFO will be applied from key - on until the LFO delay time elapses, and will then gradually diminish in effect according to the LFO fade time.

Time LFO fade time 0—127

This parameter sets the fade in or fade out time of the LFO.

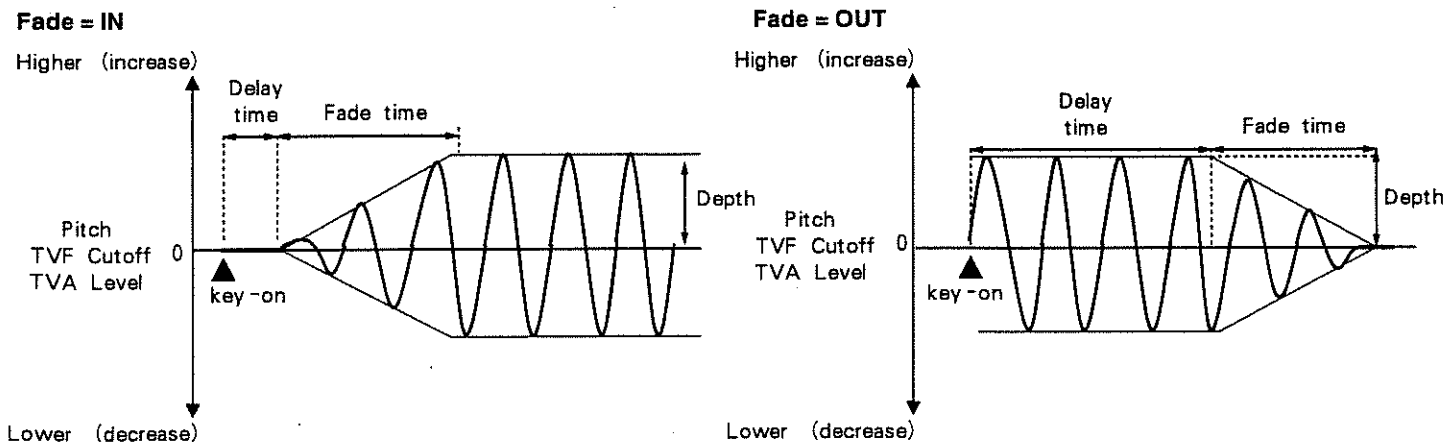

LFO DEPTH page

P1 **P2** *Pitch LFO 1 depth, Pitch LFO 2 depth* -63—+63

These parameters determine how deeply LFO 1 and 2 will affect the pitch of the Tone.

F1 **F2** *Filter LFO 1 depth, Filter LFO 2 depth* -63—+63

These parameters determine how deeply LFO 1 and 2 will affect the cutoff frequency of the Tone.

A1 **A2** *Level LFO 1 depth, Level LFO 2 depth* -63—+63

These parameters determine how deeply LFO 1 and 2 will affect the level of the Tone.

The change in pitch or volume will be opposite depending on whether Depth is positive (+) or negative (-). For example, if Depth is set to a positive (+) value for one Tone and to a negative (-) but equal value for another Tone, the two Tones will be modulated with opposite phase. This could be used to cyclically interchange two Tones, or could be used in conjunction with the Pan parameter (explained later) to create cyclic changes in stereo position.

● Parameters accessed by pressing [PITCH]

These parameters determine the pitch of the Tone.

PITCH page

Crs *Pitch shift coarse* -48—+48

This parameter shifts the pitch of the Tone in semitone steps.

Fin *Pitch shift fine* -50—+50

This parameter shifts the pitch of the Tone in steps of one "cent" (1/100 of a semitone step).

- * The pitch will change but the key number of the keyboard will not be affected. This means that the Pitch Coarse/Fine settings will not affect the range settings or the note numbers of the note messages transmitted from MIDI OUT.

Rnd *Random pitch depth*

0/5/10/20/30/40/50/70/100/200/300/400/500/600/800/1200

This parameter randomly shifts the pitch of the Tone. The parameter value is displayed in units of 1/100 of a semitone step.

P - KF *Pitch key follow*

-100/-70/-50/-30/-10/0/+10/+20/+30/+40/+50/+70/+100/+120/+150/+200

This parameter determines how the pitch of the Tone will change relative to the keyboard position. This setting is relative to the pitch of the C4 key. For positive (+) settings, the pitch will rise as the note number increases (i.e., as you play towards the right of the keyboard), and higher settings will result in a more rapid rise in pitch. For negative (-) settings, the pitch will fall as the note number increases. For standard - pitch keyboard response, the Pitch Key Follow parameter should be set at 100. If Pitch Key Follow is set at 0, all keys will produce the same pitch.

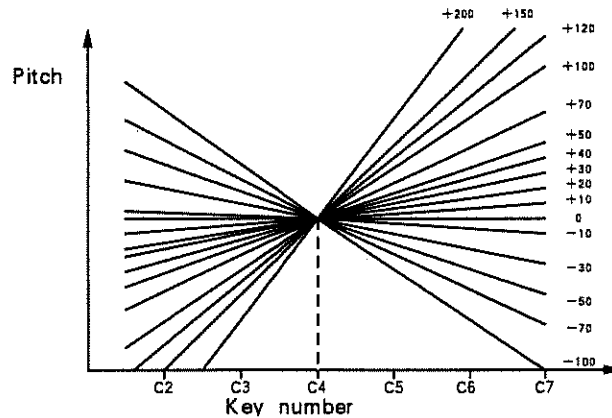

Env *Pitch envelope depth* -12—+12

This parameter determines how the Tone's pitch will change in response to the the pitch envelope level settings. When this parameter is set to a positive (+) value, the pitch will rise as the pitch envelope levels rise. When this parameter is set to a negative (-) value, the pitch will fall as the pitch envelope levels rise.

* If increasing the envelope levels does not provide enough change, increase the Depth setting.

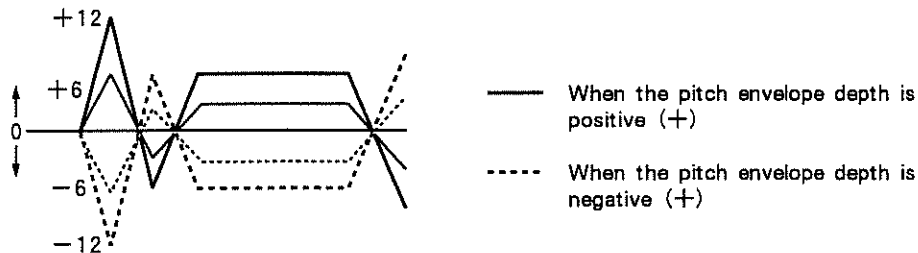

Vel *Velocity envelope level sensitivity* -63—+63

This parameter determines how the pitch envelope levels will change in response to velocity.

P - ENV (pitch envelope) page

The parameters of the following 2 pages determine how the pitch will change over time (the pitch envelope).

Velo - T1 *Velocity attack time sensitivity*

-100/-70/-50/-40/-30/-20/-10/0/+10/+20/+30/+40/+50/+70/+100

This parameter determines how velocity will affect the T1 parameter of the pitch envelope.

Velo - T4 *Velocity release time sensitivity*

-100/-70/-50/-40/-30/-20/-10/0/+10/+20/+30/+40/+50/+70/+100

This parameter determines how velocity will affect the T4 parameter of the pitch envelope.

Time - KF *Envelope time key follow*

-100/-70/-50/-40/-30/-20/-10/0/+10/+20/+30/+40/+50/+70/+100

This parameter determines how keyboard position (key number) will affect the pitch envelope time. At the C4 key the envelope times will be as specified by the envelope settings. With positive (+) settings of the Time - KF parameter, the T2 — T4 times will become shorter as the key number increases. With negative (-) settings, the T2 — T4 times will become longer. With a setting of 0, keyboard position will not affect pitch envelope times.

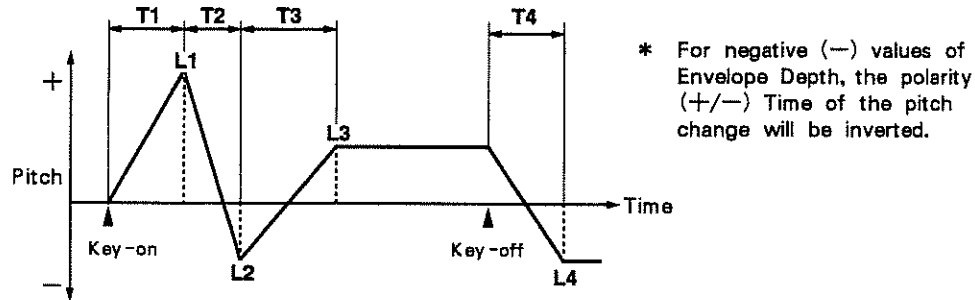

T1 **T2** **T3** **T4** 0—127

These parameters set the pitch envelope times T1, T2, T3 and T4. These determine the time over which the pitch will change to the next pitch (for example, T2 is the time over which the pitch will move from L1 to L2). Higher values will result in longer times.

L1 **L2** **L3** **L4** -63—+63

These parameters set the pitch envelope levels L1, L2, L3 and L4. These determine the pitch (change) at each point. These pitch changes are in relation to the pitch specified by the Pitch Shift and Coarse/Fine parameters. With positive (+) settings, the pitch will be raised. With negative (-) settings, the pitch will be lowered.

● Parameters accessed by pressing [TVF]

These parameters determine how the TVF will function.

TVF (filter) page

Typ *Filter type* OFF/LPF/HPF

This parameter selects the TVF type. LPF is a low - pass filter and HPF is a high - pass filter. When OFF is selected the filter will have no effect.

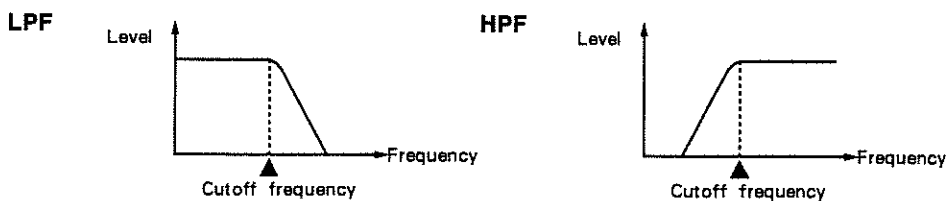

Cut *Cutoff frequency* 0—127

This parameter sets the frequency (cutoff frequency) at which the TVF will begin affecting the spectral content of the waveform.

Filter Type and Cutoff Frequency

The conventional way to use the TVF is to set the Filter Type to LPF and use the TVF to reduce the upper portion of the frequency spectrum. As the cutoff frequency is raised, more of the upper frequencies will be allowed to pass and the sound will become brighter. Conversely, as the cutoff frequency is lowered, the upper frequencies will be cut and the sound will become softer. If the Filter Type is set to HPF, raising the cutoff frequency will increasingly cut the lower frequencies, leaving only the bright portion of the sound.

Res *Resonance* 0—127

This parameter determines the amount of emphasis applied to the spectral area around the cutoff frequency.

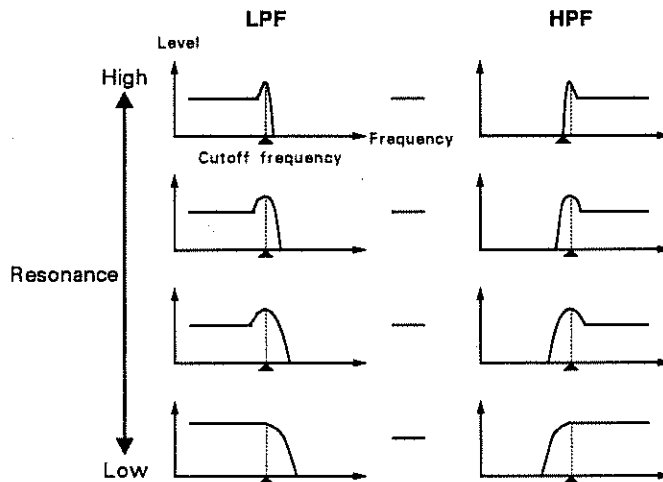

Mode *Resonance mode* SOFT/HARD

This parameter selects the type of resonance.

- * If the Tone is played with a high level or if the cutoff frequency is high, the effect of resonance may be less noticeable.

F - KF *Cutoff key follow*

-100/-70/-50/-30/-10/0/+10/+20/+30/+40/+50/+70/+100/+120/+150/+200

This parameter determines how cutoff frequency will be affected by keyboard position. With a Cutoff Key Follow setting of +100, the cutoff frequency will have the same relation to note pitch for all notes. When this parameter has a positive (+) value, higher note numbers will have an increasingly higher cutoff frequency (relative to the C4 key). As this parameter is increased, the cutoff frequency will rise more quickly. With negative (-) values, higher note numbers will have an increasingly lower cutoff frequency.

Env *TVF envelope depth* -63—+63

This parameter determines the maximum range over which the TVF envelope will affect the cutoff frequency.

TVF - ENV (TVF envelope) page

The parameters of the following two pages determine how the cutoff frequency will change over time (the TVF envelope).

Crv Velocity curve type 1—7

This parameter determines the way in which velocity will affect the cutoff frequency. A graphic indication of the curve shape will be displayed for the selected curve type.

Vel Velocity envelope level sensitivity -63—+63

This parameter determines how velocity will affect TVF envelope levels.

V - T1 Velocity attack time sensitivity

-100/-70/-50/-40/-30/-20/-10/0/+10/+20/+30/+40/+50/+70/+100

This parameter determines how velocity will affect the TVF envelope T1 parameter.

V - T4 Velocity release time sensitivity

-100/-70/-50/-40/-30/-20/-10/0/+10/+20/+30/+40/+50/+70/+100

This parameter determines how key - off velocity will affect the TVF envelope T4 parameter.

T - KF Envelope time key follow

-100/-70/-50/-40/-30/-20/-10/0/+10/+20/+30/+40/+50/+70/+100

This parameter determines how keyboard position (relative to the C4 key) will affect the TVF envelope. With positive (+) settings, T2—T4 times will become shorter as the key number increases. With negative (-) settings, T2—T4 times will become longer as the key number increases.

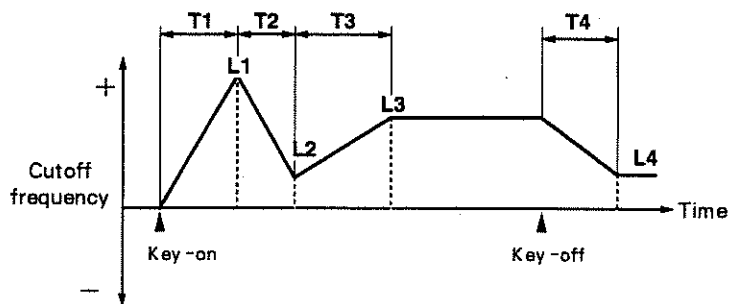

* For negative (-) values of Envelope Depth, the polarity (+/-) of the cutoff frequency change will be inverted.

T1 **T2** **T3** **T4** 0—127

These parameters set the TVF envelope times T1, T2, T3 and T4.

L1 **L2** **L3** **L4** 0—127

These parameters set the TVF envelope levels L1, L2, L3 and L4.

● Parameters accessed by pressing [TVA]

This is where you make TVA settings.

TVA page

Lev *Tone level* 0—127

This parameter determines the level of the Tone.

L - KF *Level key follow*

-100/-70/-50/-40/-30/-20/-10/0/+10/+20/+30/+40/+50/+70/+100

This parameter determines how keyboard position (key number) will affect the Tone level.

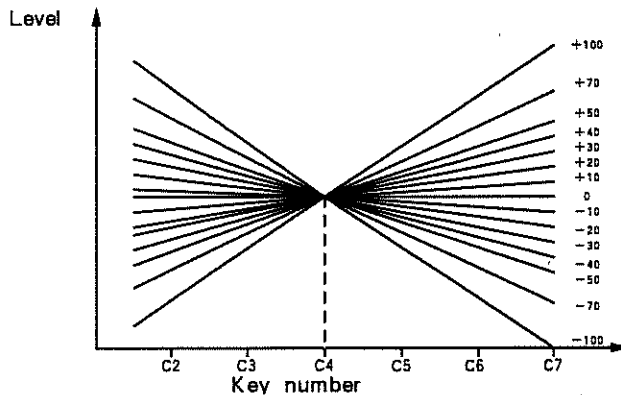

Crv *Velocity curve type* 1—7

This parameter determines the way in which velocity will affect the level. A graphic indication of the curve shape will be displayed for the selected curve type.

Vel *Velocity level sensitivity* -63—+63

This parameter determines how greatly velocity will affect the level. With positive (+) settings, the level will increase as velocity increases. With negative (-) settings, the level will increase as velocity decreases. It is also possible to give Velocity Level Sensitivity settings of -32 and +32 to different Tones, so that your playing dynamics will shift between two different sounds (velocity switch).

Pan *Pan* L64—0—63R/RND

This parameter sets the stereo location of the Tone. A setting of L64 is far left, 0 is center, and 63R is far right. With a setting of RND, the stereo location will change randomly.

P - KF *Panning key follow*

-100/-70/-50/-40/-30/-20/-10/0/+10/+20/+30/+40/+50/+70/+100

This parameter determines how keyboard position will affect the stereo location. Relative to the stereo location at the C4 key, positive (+) values will move the stereo location to the right as you play higher notes, and negative (-) values will move the stereo location to the right as you play lower notes. In either case, the movement will be greater as this Panning Key Follow is set further away from a value of 0. With a value of 0, all notes will have the same stereo location.

DELAY (tone delay) page

Mode *Tone delay mode* NORMAL/HOLD/PLAYMATE

This parameter selects the type of Tone delay. With a setting of NORMAL, Tone delay will still be valid even after the key is released. In contrast, HOLD makes Tone delay valid only while the key is held, so that if you release the key before the delay time elapses, the delayed Tone will not sound. With a setting of PLAYMATE, the delay time will be set equal to the interval between the previous note - on and the most recent note - on (only if this interval is two seconds or less, however).

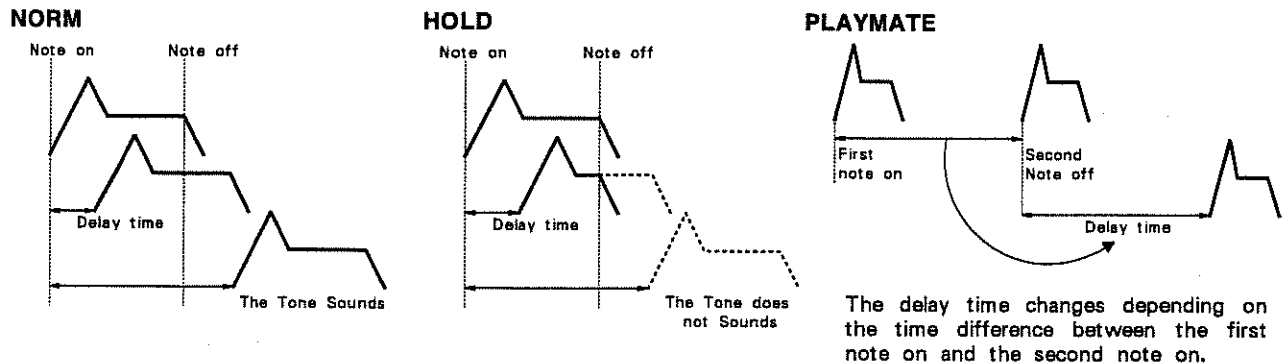

Time *Tone delay time* 0—127/KEY - OFF

This parameter sets the time delay after key - on until the Tone begins to sound. Higher values will result in a longer delay.

If the Mode parameter has been set to PLAYMATE, a Tone Delay Time setting of 64 will set the delay time to the interval between the previous note - on and the current note - on. A Tone Delay Time setting of 127 will result in a delay approximately twice as long as a setting of 64.

If the Tone Delay Time parameter is set to KEY - OFF, the delayed Tone will begin sounding when the key is released, regardless of the Mode setting. Unlike the delay produced by the effect unit, this method allows the delayed sound to have a different tonal character, or a different pitch so as to create arpeggio effects played by a single key.

- * Unlike the delay produced by the effect unit, the Tone Delay allows you to change the tonal color of the delayed note, or modify the pitch for each Tone to create arpeggios played by a single key.

TVA - ENV (TVA envelope) page

```
1---      ↑Velo-T1|Velo-T4|Time-KF|
TVA-ENV  ↓      -30|    0|    0|-----
```

Velo - T1 *Velocity attack time sensitivity*

-100/-70/-50/-40/-30/-20/-10/0/+10/+20/+30/+40/+50/+70/+100

This parameter determines how velocity will affect the TVA envelope T1 parameter.

Velo - T4 *Velocity release time sensitivity*

-100/-70/-50/-40/-30/-20/-10/0/+10/+20/+30/+40/+50/+70/+100

This parameter determines how key - off velocity will affect the TVA envelope T4 parameter.

Time - KF *Envelope time key follow*

-100/-70/-50/-40/-30/-20/-10/0/+10/+20/+30/+40/+50/+70/+100

This parameter determines how keyboard position (key number) will affect the TVA envelope. With positive (+) settings, T2—T4 times will become shorter as the key number increases. With negative (-) settings, T2—T4 times will become longer as the key number increases.

1---	↑	T1	T2	T3	T4	L1	L2	L3
TVA-ENV	↓	42	77	95	80	127	117	120 ---

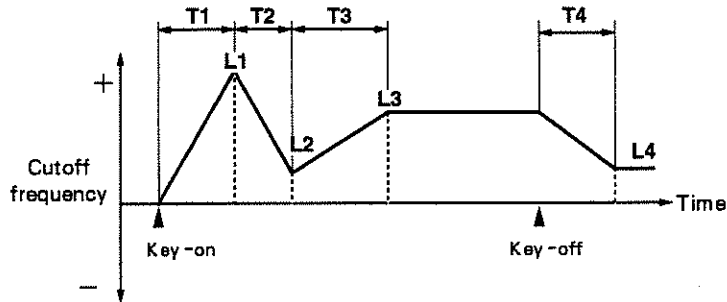

* For negative (-) values of Envelope Depth, the polarity (+/-) of the cutoff frequency change will be inverted.

T1 **T2** **T3** **T4** 0—127

These parameters set the TVA envelope times T1, T2, T3 and T4.

L1 **L2** **L3** 0—127

These parameters set the TVA envelope levels L1, L2 and L3.

2. Performance Edit mode

About the Performance Edit mode

The JV - 90 allows you to create a "Performance" that assigns seven Patches and one Rhythm Set each to their own "Part", to create an ensemble in which more than one Patch can be played simultaneously. Performance Edit mode is the mode in which you make these settings.

Operation guide

Performance Edit procedure

In Performance Play mode, select a Performance and then press EDIT. You will enter Performance Edit mode. Now press one of the function select buttons to select the desired Performance parameter.

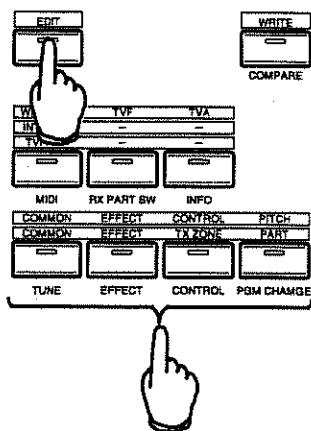

When you press [COMMON] or [EFFECT], a display like the following will appear.

[Example] when [EFFECT] is pressed

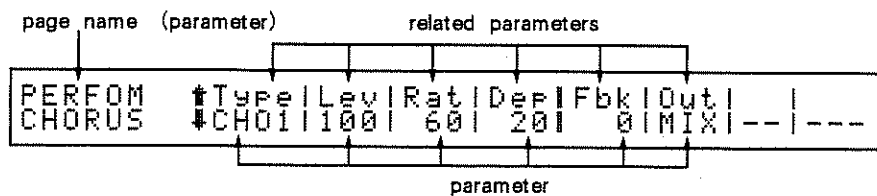

When you press [TX ZONE], [INT ZONE] or [PART], a display like the following will appear.

[Example] when [TX_ZONE] is pressed

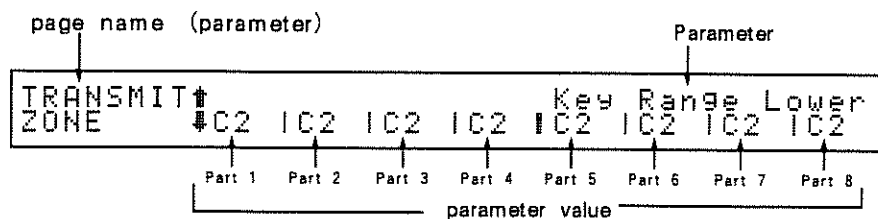

In either case, the values from left to right correspond to parameter sliders 1—8. Use the parameter sliders to modify the desired value.

[Example]

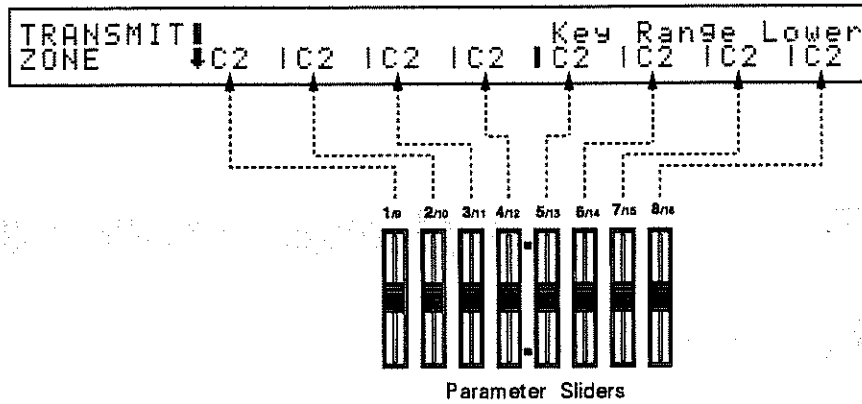

For pages in which “▲” or “▼” are displayed, you can press [▲]/[▼] to select other pages (p.7).

You can use the PART SWITCH ([1]—[8]) buttons to switch various functions for each Part, such as turning MIDI reception/transmission on or off, or specifying whether or not a Part will sound. The function switched on/off by the PART SWITCH buttons will depend on the function select button you press, as follows (p.6).

Function select button	The setting controlled by the PART
COMMON	Receive Switch
EFFECT	Chorus/Reverb Switch
TX ZONE	Transmit Switch
INT ZONE	Local Switch
PART	Receive Switch

- * To select the Part that the cursor currently points to when in the Performance mode, hold down [ENTER] while you press [PATCH]. Thereafter, you can edit that Part by pressing [EDIT]. To return to the Performance mode, press [PERFORMANCE].

Explanation of parameters

We will explain the parameters in the following order: Common, Transmit Zone, Internal Zone, and Part.

● Parameters accessed by pressing [COMMON]

These parameters are common to all Parts. These settings determine the Performance Name, Key Mode, and Effect (chorus/reverb) settings.

When this button has been pressed, the PART SWITCH ([1]—[8]) buttons will act as MIDI Receive switches to turn on/off MIDI message reception for each Part.

PERFORM NAME page

Performance Name space, A—Z, a—z, 1—9, 0, + - * / # ! , .

You can give a 12 - character name to the Performance being edited. Use parameter slider 2 or [◀]/[▶] to move the cursor, and use parameter slider 1 or [INC]/[DEC] to select characters. Create the Performance name using the same procedure as when entering a Patch name.

KEY MODE page

Mode *Key mode* LAYER/ZONE/SINGLE

	How to send the performance data	Data transmitted by MIDI
LAYER	The settings of the key range of the internal/transmit zone become invalid; 76 keys data is sent to the eight Parts and via MIDI OUT.	<ul style="list-style-type: none"> ● When the Performance is changed, program change data, as well as volume data and pan data, which are set in the transmit zone, are transmitted.
ZONE	The performance data within the key range set in the internal/transmit zone is sent to the eight Parts and via MIDI OUT.	
SINGLE	The settings of the internal/transmit zone are ignored, and only the Part at the cursor position can be controlled. Playing the keyboard sounds the Patch of the Part at the cursor position.	<ul style="list-style-type: none"> ● The receiving channel numbers which are assigned to the Parts are also used for the transmission channels. ● When the Patch is changed, bank select and program change messages, which correspond to the Patch number, are transmitted. ● When the Performance is changed, bank select and program change messages, which correspond to the Patch number that is assigned to the Part, are transmitted.

● Parameters accessed by pressing [EFFECT]

These parameters are the chorus and reverb settings. Chorus and reverb can be used to give depth or spacious stereo width to the sound.

The settings of the built-in effect unit will apply to all Parts. The effect depth for each Part is determined by the Patch parameter Send Level, but the Patch parameter effect settings for use in Patch Play mode will be ignored.

PERFORM CHORUS page

When this page is selected, the PART SWITCH ([1]—[8]) buttons will turn on/off the chorus for each Part.

Type *Chorus type* CHO1—3

This parameter selects the type of chorus effect.

CHO1	A conventional chorus.
CHO2	A chorus with slower rate. You can also apply feedback to use this as a flanger.
CHO3	A chorus with greater depth. An effect of extreme detuning can be produced.

Lev *Chorus level* 0—127

This parameter sets the level of the chorused sound.

Rat *Chorus rate* 0—127

This parameter sets the modulation speed of the chorus.

Dep *Chorus depth* 0—127

This parameter sets the depth of the chorus.

Fbk *Chorus feedback* 0—127

This parameter sets the level at which the chorused sound will be fed back into the chorus effect.

Out *Output switch* MIX/REV

This parameter specifies the output destination of the chorus sound. When MIX is selected, the chorus sound and the reverb sound will be mixed with the dry signal. When REV is selected, the chorus sound will be sent through the reverb, and then mixed with the dry signal.

PERFORM REVERB page

When this page is selected, the PART SWITCH ([1]—[8]) buttons will turn on/off the reverb for each Part.

Type *Reverb type* ROOM1—2/STAGE1—2/HALL1—2/DELAY/PAN - DLY

This parameter selects the reverb type.

ROOM1	short reverb with dense reverberation
ROOM2	short reverb with sparse reverberation
STAGE1	reverb with more late reverberation
STAGE2	reverb with strong early reflections
HALL1	clear reverb
HALL2	rich reverb
DELAY	conventional delay
PAN - DLY	delay with echoes panned left/right

Level *Reverb level* 0—127

This parameter sets the level of the reverb sound.

Time *Reverb time* 0—127

If the Reverb Type has been set to ROOM1—HALL2, this parameter sets the length of the reverberation. If the Reverb Type has been set to DELAY/PAN - DELAY, this parameter sets the delay time.

F - Back *Delay feedback* 0—127

If the Reverb Type has been set to DELAY, this parameter sets the level at which the delayed sound will be fed back into the delay. This can be used to create echo effects that repeat two or more times.

● Parameters accessed by pressing [TX ZONE]

When this button has been pressed, the PART SWITCH ([1]—[8]) buttons will act as MIDI Transmit Switches to turn on/off MIDI transmission.

Key Range Lower/Upper page

```
TRANSMIT | Key Range Lower
ZONE     ↓ C-1 IC-1 IC-1 IC-1 IC-1 IC-1 IC-1 IC-1
```

```
TRANSMIT ↑ Key Range Upper
ZONE     ↓ G9 IG9 IG9 IG9 IG9 IG9 IG9 IG9
```

Key Range Lower *Key range lower* C-1—G9

Key Range Upper *Key range upper* C-1—G9

The parameters of these two pages determine the lower and upper limits of the key range of the Transmit Zone for each part. Musical data from the keyboard will be transmitted only for notes within the specified key range.

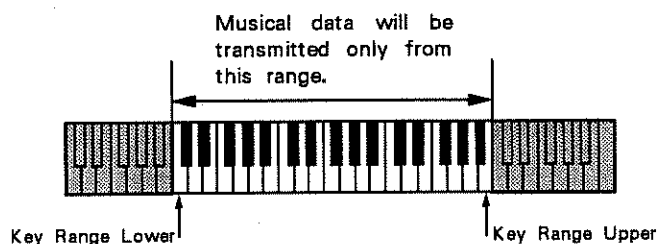

- * For the Key Range settings to have an effect, the Key Mode (p.67) must be set to ZONE.
- * It is not possible to set the Key Range Lower parameter above the Key Range Upper parameter.
- * The Key Range setting is specified as a range of keys on the JV - 90 keyboard itself, and is not affected by parameters such as Transpose, or parameters which affect the pitch of the sound. Thus, whether or not a note is in a certain Key Range depends on the physical location of the note which you press, and not on the pitch that is produced.

Transpose page

Transpose *Transpose* -36—+36

This parameter determines how notes from the keyboard will be transposed by the Transmit Zone for each Part before being transmitted from MIDI OUT.

The parameters of these three pages determine how velocity from the JV - 90's keyboard will be processed by the Transmit Zone of each Part.

Max Velocity page

Max Velocity *Max velocity* 0—127

Velocity will be limited to the Max Velocity.

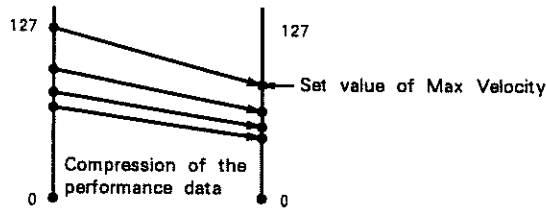

Velocity Sense page

Velocity Sense *Velocity sensitivity* -63—+63

Velocity Sensitivity will determine how playing dynamics affect the resulting velocity value. For positive (+) values of sensitivity, velocity will increase more rapidly as you play more strongly. For negative (-) values of sensitivity, velocity will increase more gradually as you play more strongly. In either case, the effect will be more pronounced as the parameter value is modified away from 0.

Velocity Curve page

Velocity Curve *Velocity curve* 1—7

In this case, the dynamics of the original velocity will be adjusted by the Velocity Curve. A graphic indication of the curve shape for the edited part will be shown in the upper right corner of the display.

[Example]

Max Velocity 100
Velocity Curve -6
Velocity Sensitivity +32
The following settings will result in a velocity response curve like that shown in the graph to the right.

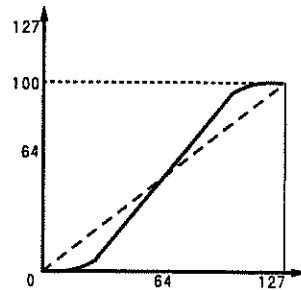

Transmit Channel page

Transmit Channel *Transmit channel* 1—16

This parameter sets the MIDI transmit channel for the Transmit Zone of each Part.

However, if the Key Mode is set to SINGLE (p.67), the transmit channel will be the same as the receive channel of the Part, and the settings in this page will be ignored.

Transmit Program Change page

Transmit Program Change *Transmit program change* A11—A88/B11—B88/OFF

This parameter specifies the Program Change number that will be transmitted by the Transmit Zone for each Part. The program change number of the edited Part is shown in the upper right corner of the display. If this parameter is set OFF, a Program Change message will not be transmitted.

- * In the Edit mode, a Program Change message will not be transmitted. The specified program change message will be transmitted when the performance is selected.

Transmit Volume page

Transmit Volume *Transmit volume* 0—127/OFF

This parameter specifies the Volume message that will be transmitted by the Transmit Zone for each Part. The maximum volume is 127. If this parameter is set OFF, a Volume message will not be transmitted.

- * The specified volume message will be transmitted when the Performance is selected.

Transmit Pan page

Transmit Pan *Transmit pan* L64—0—63R/OFF

This parameter specifies the Pan message that will be transmitted by the Transmit Zone for each Part. A value of L64 is far left, 0 is center, and 63R is far right. If this parameter is set OFF, a Pan message will not be transmitted.

- * The specified Pan message will be transmitted when the Performance is selected.

Transmit Switch page

Transmit Switch *MIDI transmit switch* ON/OFF

This parameter determines whether data will be transmitted (ON) or will not be transmitted (OFF) to MIDI OUT by the Transmit Zone for each Part. If this parameter is set OFF, the Program Change, Volume and Pan messages will not be transmitted when the Performance is selected.

- * If you use the [TX] or PART SWITCH buttons to turn on/off the MIDI transmit switches, the settings of this page will also change automatically.
- * When the Key Mode is SINGLE (p.67) these settings will have no effect.

● Parameters accessed by pressing [INT ZONE]

These parameters determine how musical data from the JV - 90 keyboard will be processed by each Internal Zone and sent to each Part.

When this button has been pressed, the PART SWITCH ([1]—[8]) buttons will act as Local switches to turn on/off reception of data from the JV - 90 keyboard for each Part.

Key Range Lower/Upper page

```
INTERNAL  Key Range Lower
ZONE     ↓C-1 IC-1 IC-1 IC-1 IC-1 IC-1 IC-1 IC-1
```

Key Range Lower *Key range lower* C-1—G9

```
INTERNAL  Key Range Upper
ZONE     ↓G9 IG9 IG9 IG9 IG9 IG9 IG9 IG9
```

Key Range Upper *Key range upper* C-1—G9

The parameters of these two pages determine the lower and upper limits of the key range for the Internal Zone of each Part. Musical data from the keyboard will be sent to each Part only for notes within the specified key range.

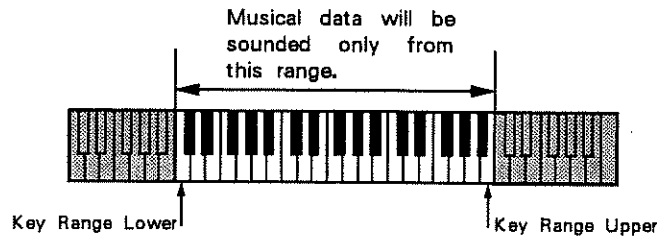

- * For the Key Range settings to have an effect, the Key Mode (p.67) must be set to ZONE.
- * It is not possible to set the Key Range Lower parameter above the Key Range Upper parameter.
- * Some commercially available ROM DATA cards contain Zone mode Performances in which the key range has been set as C2 to C7, so that notes outside this range will not sound. In such cases, copy the Performance to user memory and modify the key range.
- * Some commercially available ROM DATA cards contain Zone mode Performances in which the key range has been set as C2 to C7, so that notes outside this range will not sound. In such cases, copy the Performance to user memory and modify the key range.

Transpose page

Transpose *Transpose* -36—+36

This parameter determines how notes from the keyboard will be transposed by the Internal Zone for each Part before being sent to the Patch.

Max Velocity/Sense/Curve page

The parameters of these three pages determine how the Internal Zone will process velocities from the JV - 90 keyboard.

Max Velocity *Max velocity* 0—127

Velocity will be restricted to the value of the Max Velocity.

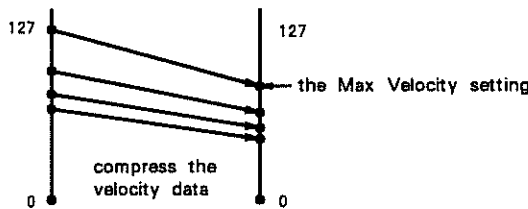

Velocity Sense *Velocity sensitivity* -63—63

Velocity Sensitivity will determine how playing dynamics affect the resulting velocity value.

for positive (+) values of Velocity Sense

for negative (-) values of Velocity Sense

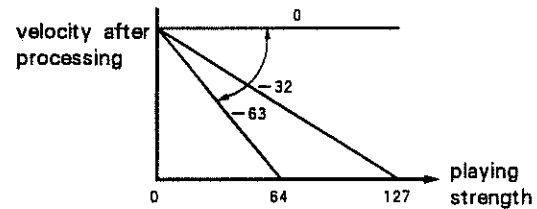
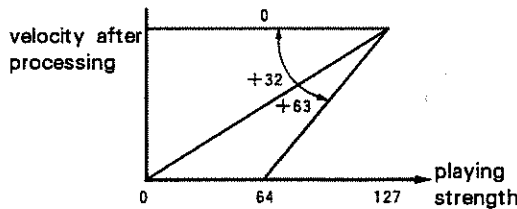

```
INTERNAL ↑      Velocity Curve P1=2 ✓
ZONE ↓      31 31 31 31 31 31 31 3
```

Velocity Curve *Velocity curve* 1—7

The dynamics of the original velocity will be adjusted by the Velocity Curve. A graphic indication of the curve shape for the edited Part will be shown in the upper right corner of the display.

[Example]

Max Velocity110

Velocity Curve4

Velocity Sensitivity-32

The following settings will result in a velocity response curve like that shown in the graph to the right.

Local Switch page

Local Switch *Local switch* ON/OFF

This parameter determines whether or not to send musical data to the Part. When this is set OFF, musical data will not be sent to the Part. Therefore, the Part is not sound by JV - 90 keyboard.

- * If you use the [TX]/[RX] and PART SWITCH buttons to turn the Local switch on/off, the settings of this page will also change automatically.
- * If the Key Mode is SINGLE (p.67), the Internal Zone settings are ignored.

● Parameters accessed by pressing [PART]

When this button has been pressed, the PART SWITCH ([1]—[8]) buttons will act as MIDI Receive switches to turn MIDI reception on/off for each Part.

Patch Select page

Patch Select *Patch select*

This parameter specifies the Patch assigned to each Part (the Rhythm Set in the case of Part 8).

- * If a PCM card has not been inserted or a Wave Expansion Board has not been installed, you will not be able to select PCM CARD or W - EXP Patch groups.

Level page

Level *Part level* 0—127

This parameter sets the level of each Part (relative to the value of the Patch parameter Level). If you do not need to adjust the volume balance between Parts, it is best to set this to the maximum value (127).

Pan page

Pan *Part pan* L64—0—63R

This parameter sets the stereo position of each Part.

Coarse Tune/Fine Tune page

Coarse Tune *Coarse tune* -48—+48

Fine Tune *Fine tune* -50—+50

The parameters of these two pages determine the pitch of the Patch assigned to each Part. Coarse Tune adjusts the pitch in semitones. Fine Tune adjusts the pitch in steps of 1/100 of a semitone.

- * These pitch adjustments are relative to the pitch of the Patch itself. The pitch that actually results will also depend on the Patch parameters.

Receive Channel page

Receive Channel *Receive channel* 1—16

This parameter sets the receive channel for each Part.

- * If you set this parameter to the same channel as the System Common parameter Control Channel (p.43), the control channel setting will take priority so that when a Program Change message is received a Performance will be selected.

Voice Reserve page

Voice Reserve *Voice reserve* 0—28

This parameter determines the number of voices that will be reserved for each Part. Since each note played by a Patch will require as many voices as the Patch has Tones, you should set this parameter to the number of notes you wish to reserve, multiplied by the number of Tones used by the Patch. It is not possible to make Voice Reserve settings that would total more than 28 for all Parts.

The maximum number of voices (notes) that can be played simultaneously will depend on how many Tones are used in a Patch. If, for example, a Patch uses only one Tone, then up to 28 notes can be played simultaneously. If, however, a Patch uses two Tones, then only 14 notes can be played at the same time. (Refer to page 33 “the number of voices used”.)

Chorus Switch page

Chorus Switch *Chorus switch* ON/OFF

This parameter determines whether the signal will be sent to the chorus (ON) or not (OFF).

Reverb Switch page

Reverb Switch *Reverb switch* ON/OFF

This parameter determines whether the signal will be sent to the reverb (ON) or not (OFF).

Receive Program Change page

Receive Program Change *Program change receive switch* ON/OFF

This parameter determines whether each Part will receive Program Change messages (ON) or not (OFF).

Receive Volume page

Receive Volume *Volume receive switch* ON/OFF

This parameter determines whether each Part will receive Volume messages (ON) or not (OFF).

Receive Hold - 1 page

Receive Hold - 1 *Hold 1 receive switch* ON/OFF

This parameter determines whether each Part will receive Hold 1 messages (ON) or not (OFF).

Receive Switch page

Receive Switch *MIDI receive switch* ON/OFF

This parameter determines whether each Part will receive MIDI data (ON) or not (OFF).

- * If you use the [RX] or PART SWITCH buttons to turn the MIDI Receive Switch on/off, the settings in this page will also change automatically.

3. Rhythm Edit mode

This section explains how to edit a Rhythm Tone, and the role of each parameter.

■ About the Rhythm Edit mode

In Rhythm Edit mode you can edit the rhythm sounds (rhythm instruments) assigned to a Rhythm Set.

Each rhythm instrument is assigned to a key, and a set of instruments for each key is stored as a Rhythm Set. One Rhythm Set can be stored in internal memory (INT), and another can be stored in a DATA card (CARD).

- * In Rhythm mode, the effect unit will use the settings of the Performance which is currently in the temporary area.
- * Page 131 lists the Rhythm Tones assigned to each key at the factory.

■ Procedure

● Rhythm editing procedure

- (1) Press [RHYTHM] and you will enter Rhythm Play mode. The Rhythm Set selected for Part 8 of the current Performance will be selected. If you wish to edit another Rhythm Set, use the PATCH GROUP SWITCH to select the memory of the desired Rhythm Set.
- (2) Press [EDIT] to enter Rhythm Edit mode.

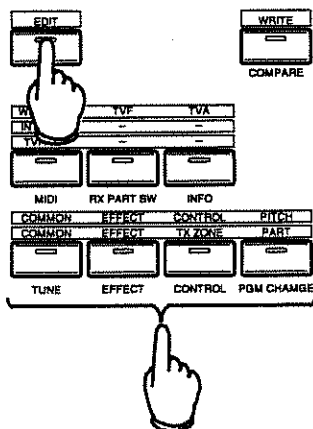

(3) In Rhythm Edit mode, screens like the following will be displayed.

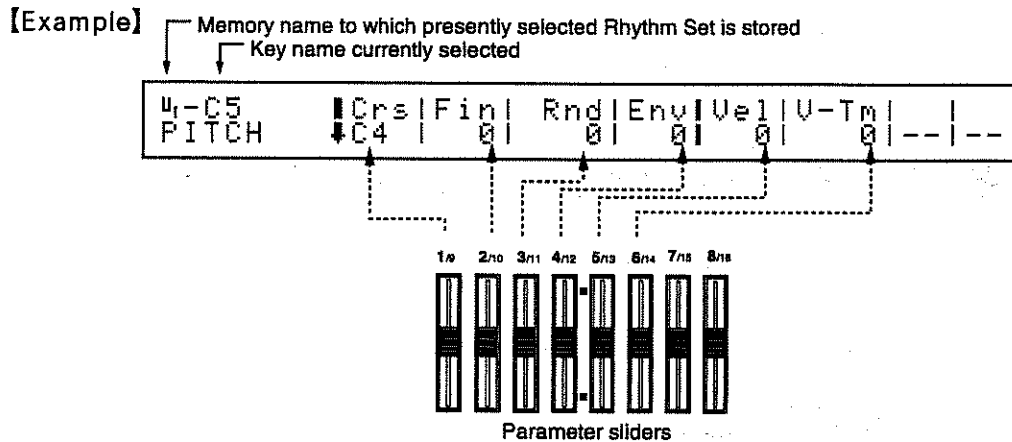

The values from the left correspond to parameter sliders 1 — 8. Move the appropriate parameter slider to modify the desired value.

For pages in which “▲” or “▼” are displayed, you can press [▲]/[▼] to select other screens.

(4) The upper left of the display will show a symbol indicating the memory of the Rhythm Set of the currently selected Rhythm Tone, and the key name to which the Rhythm Tone is assigned. To select a Rhythm Tone to edit, you can either press the key to which that Rhythm Tone is assigned, or press TONE SELECT [1]—[4]. The key name display will change to indicate the selected key.

TONE SELECT 1

Each time you press this button, the currently displayed key name will go down one octave.

TONE SELECT 2

Each time you press this button, the key name will go down a semitone.

TONE SELECT 3

Each time you press this button, the key name will go up a semitone.

TONE SELECT 4

Each time you press this button, the currently displayed key name will go up one octave.

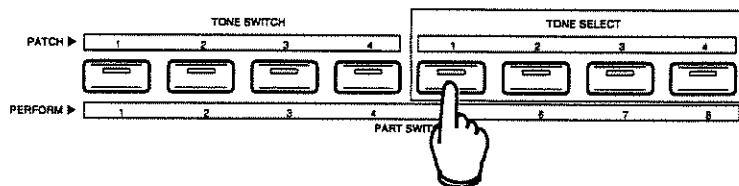

■ Explanation of parameters

Here we will explain the parameters you can set in Rhythm Tone Edit mode, and how to use the buttons.

● Parameters accessed by pressing [EFFECT]

FX SEND (effect send) page

Dry *Dry level* 0—127

This parameter sets the level of the dry sound (not processed by the effect).

Chorus *Chorus send level* 0—127

This parameter sets the level of the sound sent to the chorus.

Reverb *Reverb send level* 0—127

This parameter sets the level of the sound sent to the reverb.

PERFORM CHORUS/REVERB (Performance chorus/reverb) page

The following two pages contain parameters for chorus and reverb. Be aware that these are Performance parameters which have been read into the temporary area. This means that effect unit settings you make here for a Rhythm Set need to be stored as Performance data. However, if this Rhythm Set is selected from a different Performance, the effect settings of that Performance will be used.

Type *Chorus type* CHO1—3

This parameter selects the type of chorus effect.

CHO1	A conventional chorus.
CHO2	A chorus with slower rate. You can also apply feedback to use this as a flanger.
CHO3	A chorus with greater depth. An effect of extreme detuning can be produced.

Lev *Chorus level* 0—127

This parameter sets the level of the chorused sound.

Rat *Chorus rate* 0—127

This parameter sets the modulation speed of the chorus.

Dep *Chorus depth* 0—127

This parameter sets the modulation depth of the chorus.

Fbk *Chorus feedback* 0—127

This parameter sets the level of the chorused sound that is fed back into the chorus. This allows more complex chorus effects to be produced.

Out *Output switch* MIX/REV

This parameter specifies the output destination of the chorus. When MIX is selected, the chorus sound and reverb sound will be mixed with the dry sound. When REV is selected, the chorus sound will be sent through the reverb and then mixed with the dry sound.

Type *Reverb type* ROOM1 — 2/STAGE1 — 2/HALL1 — 2/DELAY/PAN - DRY

This parameter selects the type of reverb.

ROOM1	short reverb with dense reverberation
ROOM2	short reverb with sparse reverberation
STAGE1	reverb with more late reverberation
STAGE2	reverb with strong early reflections
HALL1	clear reverb
HALL2	rich reverb
DELAY	conventional delay
PAN - DLY	delay with echoes panned left/right

Level *Reverb level* 0—127

This parameter sets the level of the reverb sound.

Time *Reverb time* 0—127

If the Reverb Type has been set to ROOM1 — HALL2, this parameter sets the length of reverberation. If the Reverb Type has been set to DELAY/PAN - DLY, this parameter sets the delay time.

F - Back *Delay feedback* 0—127

If the Reverb Type has been set to DELAY, this parameter sets the level of the delayed sound that is fed back into the delay.

● **Parameters accessed by pressing [CONTROL]**

CONTROL page

Bender *Bend range* 0—12

This parameter determines the range of pitch change that results when the bender/modulation lever is moved to right or left.

Env - Mode *Envelope mode* NO - SUS/SUS

This parameter determines how the Rhythm Tone will be sounded. When NO - SUS is selected, the time between the sustain level (L3) and the key - off will be ignored, and the decay will begin immediately. This means that the sound will always end after the same length of time (T1+T2+T3+T4). When SUS is selected, the sustain level will be maintained until key - off. This allows you to use key - off to mute the Rhythm Tone.

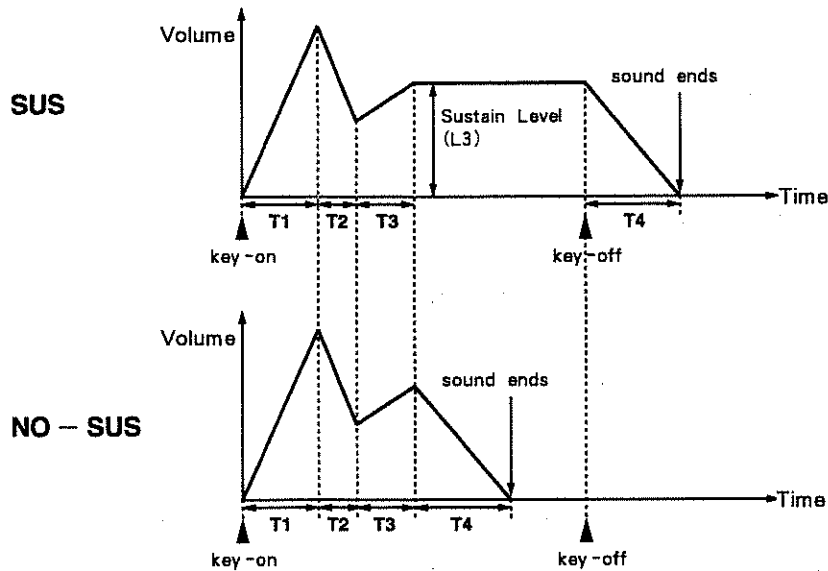

Mute - Grp *Mute group* OFF/1 — 31

This parameter assigns the Rhythm Tone to a Mute Group. When a Rhythm Tone is sounded, any other currently sounding Rhythm Tone in the same mute group will be muted. 31 separate mute groups can be used. When OFF is selected, that Rhythm Tone will not mute any other Rhythm Tone, nor will it be muted by any other Rhythm Tone.

● **Parameters accessed by pressing [WAVE/LFO]**

WAVE page

```
UI-C2 | Switch|Group| No |
WAVE | | ON| INT| 87(LA Snare | )
```

Switch *Tone switch* ON/OFF

This parameter specifies whether the currently selected Rhythm Tone will be sounded (ON) or not (OFF).

Group *Wave group* INT/EXP/CARD

In the same way as for a standard Tone, you can select the waveform that will be the basis of the Rhythm Tone. The Wave Group parameter specifies the memory from which the waveform will be read: Internal (INT), Wave Expansion Board (EXP) or PCM card (PCM).

No *Wave number*

This parameter specifies a waveform from the selected wave group. The wave name of the selected number will be displayed in parentheses ().

● Parameters accessed by pressing [PITCH]

PITCH page

Crs Pitch coarse C-1—G9

This parameter selects the key pitch within the waveform to be sounded.

- * Some waveforms have an upper pitch limit. If you set Pitch Coarse above this limit, the waveform will sound at its upper pitch limit.

Fin Pitch shift fine -50—+50

This parameter adjusts the pitch of the Rhythm Tone in steps of 1/100 of a semitone.

Rnd Random pitch depth

0/5/10/20/30/40/50/70/100/200/300/400/500/600/800/1200

This parameter adds random variation to the pitch of the Rhythm Tone within the specified range. The setting value is in units of 1/100 of a semitone.

Env Pitch envelope depth -12—+12

This parameter determines the maximum pitch change produced by the pitch envelope.

Vel Velocity envelope level sensitivity -63—+63

This parameter determines how velocity will affect the pitch envelope levels.

V-Tm Velocity envelope time sensitivity

-100/-70/-50/-40/-30/-20/-10/0/+10/+20/+30/+40/+50/+70/+100

This parameter determines how velocity will affect the overall pitch envelope time.

P-ENV (pitch envelope) page

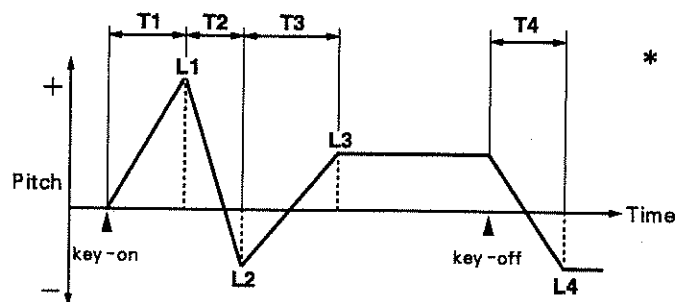

* For negative (-) values of Envelope Depth, the polarity (+/-) of the pitch change will be inverted.

T1 **T2** **T3** **T4** 0—127

These parameters set the pitch envelope times T1, T2, T3 and T4. These determine the time over which one pitch will change to the next (for example, from L1 to L2).

L1 **L2** **L3** **L4** -63—+63

These parameters set the pitch envelope levels L1, L2, L3 and L4. These determine the pitch (change) at each point.

● Parameters accessed by pressing [TVF]

These parameters determine how the TVF will function.

TVF page

Typ *Filter type* LPF/HPF/OFF

This parameter selects the TVF type. LPF is a low - pass filter and HPF is a high - pass filter. When OFF is selected the filter will have no effect.

Cut *Cutoff frequency* 0—127

This parameter sets the frequency (cutoff frequency) at which the TVF will begin affecting the frequencies of the waveform.

Res *Resonance* 0—127

This parameter determines the amount of emphasis applied to the frequencies around the cutoff frequency.

Mode *Resonance mode* SOFT/HARD

This parameter selects the type of resonance. When SOFT is selected the resonance will be soft, and when HARD is selected, the resonance will be sharp.

* If the Tone is played with a high level, or if the cutoff frequency is high, the effect of resonance may be less noticeable.

Env *TVF envelope depth* -63—+63

This parameter determines the maximum range over which the TVF envelope will affect the cutoff frequency.

Cutoff frequency

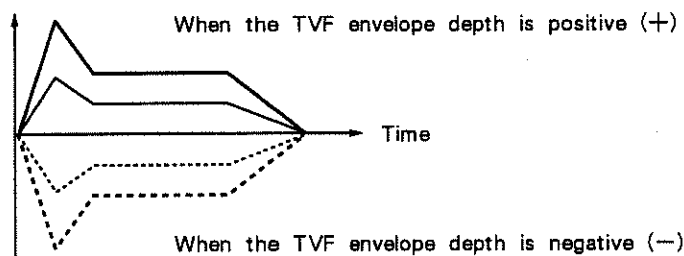

Vel *Velocity envelope level sensitivity* -63—+63

This parameter determines how velocity will affect TVF envelope levels.

V - Tm *Velocity time sensitivity*

-100/-70/-50/-40/-30/-20/-10/0/+10/+20/+30/+40/+50/+70/+100

This parameter determines how velocity will affect the overall TVF envelope times.

TVF - ENV (TVF envelope) page

The parameters in this page determine how the cutoff frequency will change over time (TVF envelope).

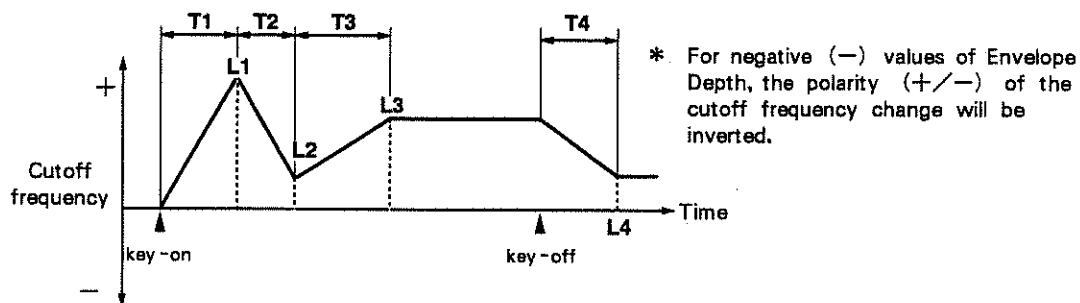

T1 **T2** **T3** **T4** 0—127

These parameters set the TVF envelope times T1, T2, T3 and T4. These will determine the time over which the cutoff frequency will move from one level to the next (for example from L1 to L2).

L1 **L2** **L3** **L4** 0—127

These parameters set the TVF envelope levels L1, L2, L3 and L4. These will determine the cutoff frequency at each point. The values you set here are adjusted by the TVF Envelope Depth parameter before they are applied to the cutoff frequency.

● Parameters accessed by pressing [TVA]

These parameters determine how the TVA will function.

TVA page

Level *Tone level* 0—127

This parameter determines the level of the Rhythm Tone.

Velo *Velocity level sensitivity* -63—+63

This parameter determines how greatly velocity will affect the level.

V - Time *Velocity time sensitivity*

-100/-70/-50/-40/-30/-20/-10/0/+10/+20/+30/+40/+50/+70/+100

This parameter determines how velocity will affect the overall time of the TVA envelope.

Pan *Pan* L64—0—63R/RND

This parameter determines the stereo position of the Rhythm Tone. With a setting of RND, the stereo position will change randomly.

TVA - ENV page

This page contains parameters which determine how the level will change over time (TVA envelope).

UI-C2	↑	T1	T2	T3	T4	L1	L2	L3	
TVA-ENV	↓	0	10	30	70	127	100	85	---

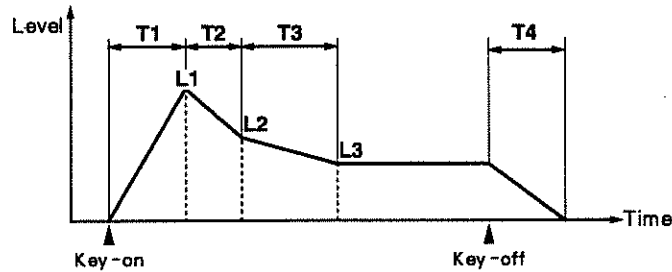

T1 **T2** **T3** **T4** 0—127

These parameters set the TVA envelope times T1, T2, T3 and T4. These will determine the time over which the volume will change from one level to the next (for example from L1 to L2)

L1 **L2** **L3** 0—127

These parameters set the TVA envelope levels L1, L2 and L3. These will determine the volume at each point. Higher levels result in higher levels. For the TVA envelope, the envelope level following key - off will be 0.

4. Commands

Write mode

Write mode is the mode in which you perform data management operations such as writing edited data into memory, or copying or transmitting data.

- * Data management operations are called "commands", and to use a command to perform an operation is to "execute" the command.

Operation guide

- (1) In Patch Play mode or any other mode, press [WRITE]. You will enter Write mode and the following will appear in the display of the synthesizer sound source section.

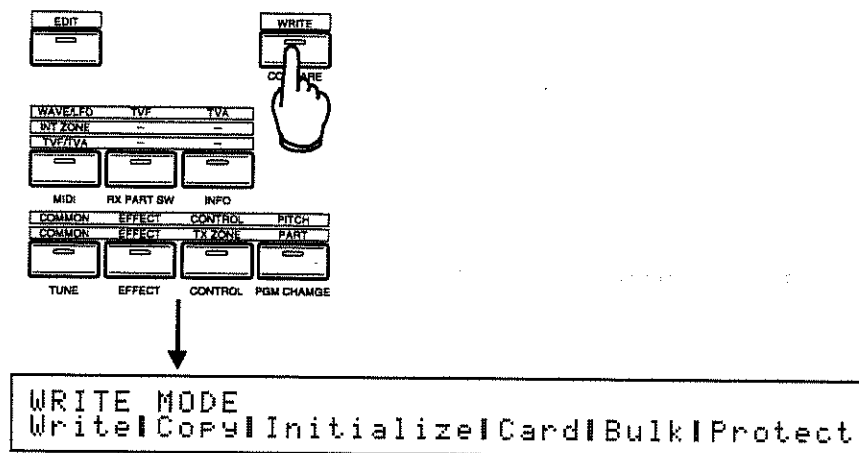

- (2) Use [◀]/[▶] or parameter slider 1 to select the command you wish to execute. The selected command will blink.
- (3) Press [ENTER] and the command setting display will appear.
- (4) When you are expected to execute the command, the synthesizer sound source display will read Press [ENTER]. After you finish making all necessary settings, press [ENTER] to execute the command. When complete, the following display will appear.

Complete

The display which appears before pressing [WRITE].

The display will show "Complete", and you will then be returned to the display (mode) before you pressed [WRITE] and the mode before you entered command mode.

- * If you wish to quit without executing, press [EXIT]. Each time you press the button you will return to the immediately previous display.
- * If "▲" or "▼" appears in the command setting display, you can use [▲]/[▼] to select other displays.

The settings for step (4) will be explained in the sections covering each command.

Write

The Write command writes edited data into user memory (such as internal memory or a DATA card).

The display that appears will depend on the mode from which you pressed [WRITE].

- * When writing data into internal user memory, protect (p.99) must be turned off. If you attempt to write data while protect is on, a warning message will appear, and then the protect on/off setting display will appear. Use [◀|/▶] to get the word "Internal" to blink, and then press [DEC] to turn protect off.
- * When writing data into a DATA card, turn the protect switch of the DATA card off while it is inserted into the DATA card slot. After writing the data, turn the protect switch on to protect the data.

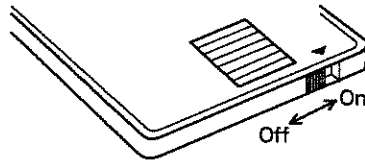

Performance Play/Performance Edit Mode → Write

PERFORM WRITE *Perform write*

By pressing [WRITE] from Performance Play mode or Performance Edit mode, you can write the data of the temporary area into a Performance.

```
PERFORM |from TEMP [Press ENTER]
WRITE |to UI01(Milky Way )
```

Performance name of writing destination
Performance number of writing destination (I = internal, C = DATA card)

[Procedure]

Use the Patch group switches and BANK/NUMBER (or [INC]/[DEC] and parameter slider 1) to select the Performance number into which you wish to write the data. The name of the selected Performance will be displayed in parentheses ().

```
PERFORM |from TEMP [Press ENTER]
WRITE |to UI01(Milky Way )
```

Pressing [PATCH] in the above display will turn the JV - 90 to the mode that allows you to write the Performance data and the Patch used in the Performance all at once.

The display shows the destination Patch of each Part.

```
PERFORM |with these patches[Press ENTER]
WRITE  |A11|---|A13|---|I15|C16|I17|UI
```

Here, the JV - 90 compares the data on the Temporary and Patch in each Media. Since it is unnecessary to write the same data, " --- " is shown instead of the Patch Number.

Now, you can change the destination Patch Numbers using the Parameter Slider, Cursor or [INC]/[DEC]. The same Patch Number, however, cannot be selected.

When " --- " is selected, the Patch in that Part is not written.

Performance data will be written into the new Patch Number selected here.

If you wish to compare the Temporary Patch at the cursor position with the destination Patch, press [WRITE] here. To leave the Compare mode, simply press [WRITE] again.

Pressing [ENTER] causes the screen to show the following message.

```
PERFORM |to UI01 |---|---|---|---|[Sure? Press ENTER]
WRITE  |---|---|---|---|I15|I16|I17|UI
```

Here, the Parts that used to have the destination Media that could not be written, such as Preset, in the previous display are shown as " --- ", and therefore will not be written. To write data, select UI or UC.

Press [ENTER], and the specified Part will be written, then the screen will be returned to the previous display before the unit being turned to the WRITE mode.

- * If you write the new Patch into the Patch used for the other Performance, the Performance will sound different.

Patch Play/Patch Edit Mode → Write

PATCH WRITE *Patch write*

By pressing [WRITE] from Patch Play mode or Patch Edit mode, you can write the data of the temporary area into a Patch.

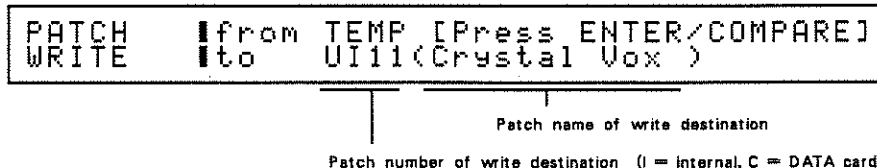

[Procedure]

Use the Patch group switches and BANK/NUMBER (or [INC]/[DEC] and parameter slider 1) to select the Patch number into which you wish to write the data. The name of the selected Patch will be displayed in parentheses ().

Next, press [WRITE (COMPARE)] and the Patch Compare display will appear, allowing you to check the sound of the writing destination Patch.

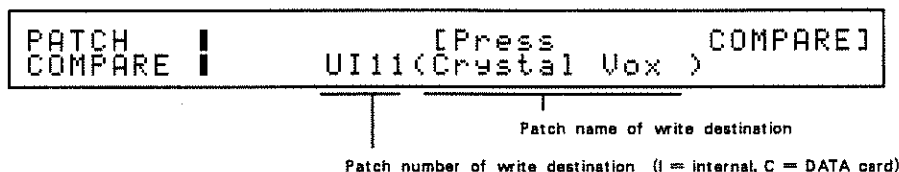

In this display you can still change Patch numbers. After checking the sound of the Patch to make sure of the writing destination, press [WRITE (COMPARE)]. (You will return to the Patch Write display.)

Rhythm Play/Rhythm Edit Mode → Write

RHYTHM WRITE *Rhythm set write*

By pressing [WRITE] from Rhythm Play mode or Rhythm Edit mode, you can write the data of the temporary area into a Rhythm Set.

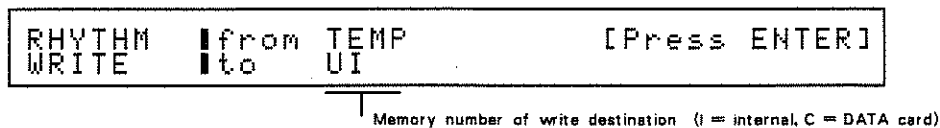

[Procedure]

Use the Patch group switches (or [INC]/[DEC], BANK/NUMBER, and parameter slider 1) to select the Rhythm Set into which you wish to write the data.

● Copy

These commands copy Performance, Patch, or Tone data into the temporary area.

Performance Play/Performance Edit Mode → Copy

Performance part copy

This command copies a specified Part of a Performance into a Part of the Performance in the temporary area.

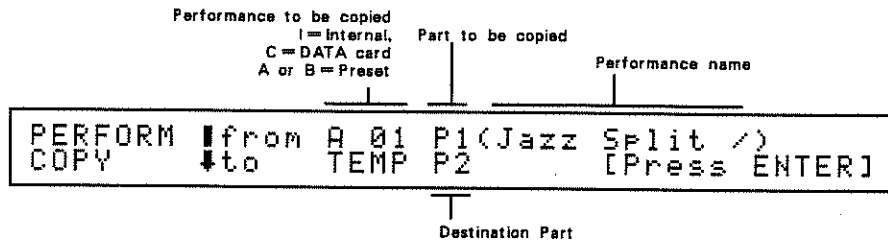

[Procedure]

Use the Patch group switches and BANK/NUMBER (or [INC]/[DEC] and parameter slider 1) to select the Performance number from which you wish to copy the data. The name of the selected Performance will be displayed in parentheses ().

Select the Part from which you wish to copy using parameter slider 2, or use [◀]/[▶] to move the cursor and [INC]/[DEC] to make the selection.

Use PART SWITCH ([1]—[8]) to select the copy destination part.

If the Part to be copied is "TEMP", it will be the temporary area of performance.

Press [WRITE] to choose "TEMP".

Performance common copy

This command copies the Performance name, key mode, and effect unit settings from a selected Performance in memory into the Performance in the temporary area.

```
PERFORM 1 from A 01 COMMON(Jazz Split /)
COPY     ↓ to  TEMP          [Press ENTER]
```

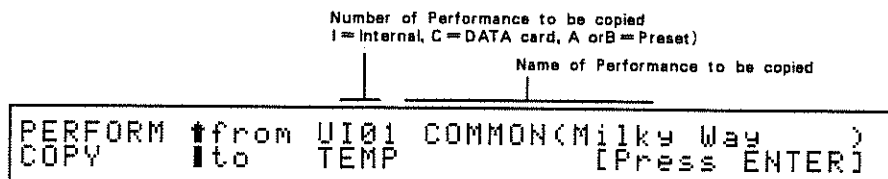

[Procedure]

Select the copy source Performance number using the Patch group switches and BANK/NUMBER (or [INC]/[DEC] and parameter slider 1). The name of the selected Performance will be displayed in parentheses ().

Patch Play/Patch Edit Mode → Copy

Patch tone copy

This command copies data from a selected Tone of a Patch into the specified Tone of the Patch in the temporary area.

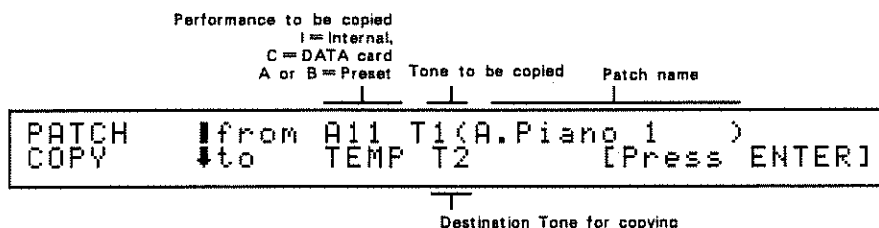

[Procedure]

Select the copy source Patch number using the Patch group switches and BANK/NUMBER (or [INC]/[DEC] and parameter slider 1). The name of the selected Patch will be displayed in parentheses ().

Select the copy source Tone using parameter slider 2, or use [◀]/[▶] to move the cursor and use [INC]/[DEC] to make the selection.

If the tone to be copied is "TEMP", it will be the temporary area of patch. Press [WRITE] to choose "TEMP".

Specify the copy destination Tone using TONE SELECT([1]—[4]).

Patch common copy

This command copies parameters common to all Tones from a selected Patch into the Patch in the temporary area.

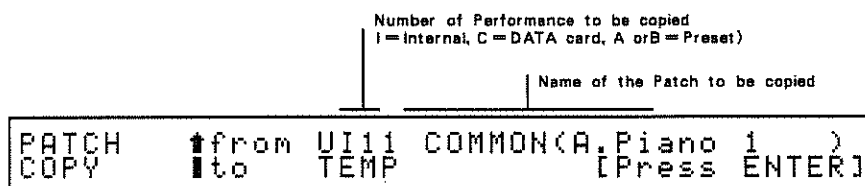

* This will copy data such as effect unit settings, key assign (POLY/SOLO), etc. (→ Patch Edit mode, p.48)

[Procedure]

Select the copy source Patch number using the Patch group switches and BANK/NUMBER (or [INC]/[DEC] and parameter slider 1). The name of the selected Patch will be displayed in parentheses ().

Rhythm Play/Rhythm Edit Mode → Copy

Rhythm key copy

This command copies the Rhythm Tone data of a key in a specified Rhythm Set into a key of the Rhythm Set in the temporary area.

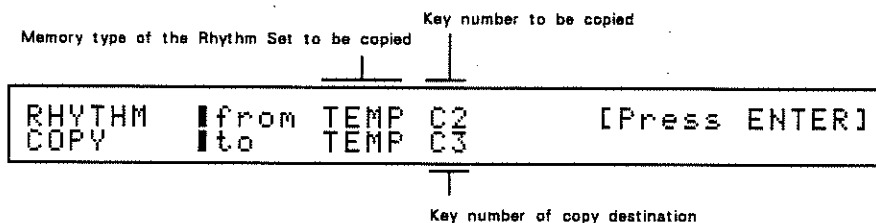

[Procedure]

Select the copy source memory using the Patch group switches and BANK/NUMBER (or [INC]/[DEC] and parameter slider 1).

Select the copy source key number using parameter slider 2, or use [◀]/[▶] to move the cursor and use [INC]/[DEC] to make the selection.

Specify the copy destination key number by pressing the desired key of the keyboard.

If the Rhythm Set to be copied is "TEMP", it will be the temporary area of rhythm set. Press [WRITE] to choose "TEMP".

● Initialize

Initialization is an operation which erases the data currently in the Temporary Area and restores the unit's internal factory settings (the current Bank No.) on the internal area.

- * Initialization automatically erases any data you have created in the Temporary Area.
- * To initialize all the data in the JV - 90, switch off the unit, then switch it on again while holding down [16] in PATCH GROUP.

Performance Play/Performance Edit Mode → Initialize

Performance Initialize

This operation erases the Performance data currently in the Temporary Area and restores the internal factory setting on the internal area (P.127) for that Performance Number.

Patch Play/Patch Edit Mode → Initialize

Patch Initialize

This operation initializes the Patch data currently in the Temporary Area and restores the internal factory setting (P.127) for that Patch Number.

- * If you want to select the patch, "INITIAL DATA" in JV - 1000/80, please select JV - 80 compatible preset b88. (P.130)

Rhythm Play/Rhythm Edit Mode → Initialize

Rhythm Key Initialize

This operation does not initialize the entire Rhythm Set currently in the Temporary Area, but initializes only the Rhythm Tone data assigned to a specified key.

- * You can specify the key to be initialized by pressing it.

Rhythm Set Initialize

This operation initializes the Rhythm Set currently in the Temporary Area.

● Card

These commands transfer data between the JV - 90 and a DATA card. When you select this command, a display will appear allowing you to select the type of operation.

```
DATA CARD
Int→Card|Card→Int|Int↔Card
```

[Procedure]

Use [◀]/[▶] or parameter slider 1 to select the desired item (the selected item will blink) and press [ENTER].

Note

The JV - 90 allows you to create Performances which use both internal and DATA card Patches. If you copy such a Performance from internal memory to a DATA card, or from a DATA card to internal memory, you should be aware that the following situation will occur.

Example : Suppose that there is a Performance UI01 (User Internal 01) which assigns a Patch UI12 to Part 1 and UC11 to Part 2. When this Performance is copied from internal memory to DATA card, this Performance will be stored in the DATA card as "UC01"(User card 01). The Patch assignment for Part 1 will be stored as "UC12" and the Patch assignment for Part 2 will remain UC11.

If you later copy the data from the DATA card back to internal memory, the Performance will be stored in internal memory as "UI01" with Part 1 as "UI12", but Part 2 will be stored as "UI11", meaning that even though the Performance number is the same, the Patch number specified by Part 2 has now changed.

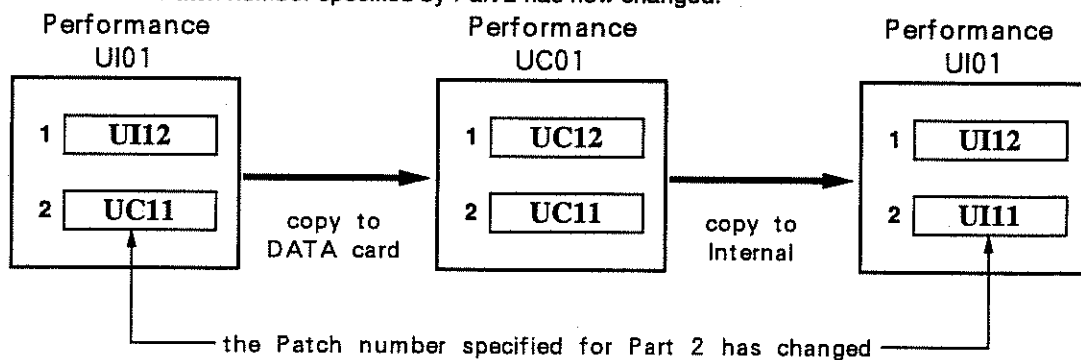

If you wish to save internal data just as it is, use the Bulk Dump command (p.96).

COPY INTERNAL → DATA CARD

```
CARD      | INTERNAL→DATA CARD  
COPY      |                               [Press ENTER]
```

This command copies all the Performance, Patch, and Rhythm Set data in internal memory to a DATA card.

- * When this command is executed using a new DATA card (or a DATA card that has been used by another device), the DATA card will be formatted (initialized) for the JV - 90.

COPY DATA CARD → INTERNAL

```
CARD      | DATA CARD→INTERNAL  
COPY      |                               [Press ENTER]
```

This command copies all the Performance, Patch, and Rhythm Set data in a DATA card to internal memory.

COPY INTERNAL ↔ DATA CARD

```
CARD      | INTERNAL↔DATA CARD  
COPY      |                               [Press ENTER]
```

This command exchanges all the Performance, Patch, and Rhythm Set data in a DATA card with the data in internal memory.

● Bulk (bulk dump)

These commands transmit Patch or Tone data from internal memory or the temporary area via MIDI to the sequencer section, or to a MIDI device that is able to store bulk data. In this case, the MIDI channels and device ID number (P.44) of the transmitting and receiving devices must match. (To set the device ID number (P.44), press MIDI and make settings in the SYS - EX MIDI page.)

- * Data is transmitted using the "one way" protocol.

When this command is selected, a display will appear allowing you to select the memory from which data is to be transmitted.

```
BULK DUMP  
Internal|Card|Temporary
```

[Procedure]

Select the desired item using [◀][▶] or parameter slider 1 (the selected item will blink), and press [ENTER].

If you have selected "Temporary", another display will appear allowing you to specify the type of data to be transmitted.

```
BULK DUMP TEMPORARY
Performance|Patch|Rhythm|All
```

Here, too, use [◀][▶] or parameter slider 1 to select the desired item (the selected item will blink), and press [ENTER].

When you have specified the data to be transmitted, press [ENTER]. The display will read "Now Sending", and transmission will begin.

After a while the display will read "Complete", indicating that data transmission has ended.

INTERNAL DATA

Internal data

This command transmits all data from the JV - 90 internal memory; Performance, Patch, and Rhythm Set data.

CARD DATA

Card data

This command transmits all data from a DATA card; Performance, Patch, and Rhythm Set data.

PERFORMANCE TEMP

Performance temporary

This command transmits the Performance data from the temporary area.

PATCH TEMP

Patch temporary

This command transmits the Patch data from the temporary area.

RHYTHM TEMP

Rhythm temporary

This command transmits the Rhythm Set data from the temporary area.

ALL TEMP

All temporary

This command transmits the Patch and Rhythm Set data for the Performance in the temporary area.

If the Voice Expansion Board is connected to the JV - 90, the following commands can be used.

INT → V - EXP (Internal → Voice Expansion)

This function can be used to set the VE - GS1 to the actual panel settings. (This may be necessary when the panel settings in the Voice Expansion mode differ from the VE - GS1's actual settings because the V - EXP MIDI IN Selector Switch was set to EXT.)

If, however, the JV - 90 was in the Performance mode before entering the Write mode, this command transfers the Temporary Area in the Performance mode to the VE - JV1. By executing this command, you can play the loaded Performance using the VE - JV1 (rather than the JV - 90's internal sound module).

If the JV - 90 was in the Voice Expansion mode before entering the Write mode, this command transfers the Temporary Area settings in the Voice Expansion mode to the VE - JV1.

You can also use this function to match the VE - JV1 to the settings of the Temporary Area in the Voice Expansion mode when the settings differ because the V - EXP MIDI IN Selector Switch was set to EXT.

V - EXP → INT (Voice Expansion → Internal)

This command transfers the parameter data on the VE - GS1 to the JV - 90. This can be used to match the panel settings to the VE - GS1's settings when the panel settings in the Voice Expansion mode differ (because the V - EXP MIDI IN Selector Switch is set to EXT).

If the JV - 90 was in the Performance mode before entering the Write mode, this command transfers the settings of the VE - JV1 to the Temporary Area in the Performance mode. By executing this command, you can play the loaded Performance on the JV - 90's sound module (rather than on the VE - JV1).

If the JV - 90 was in the Voice Expansion mode before entering the Write mode, this command transfers the Parameter data of the VE - JV1 to the Temporary Area in the Voice Expansion mode. You can use this operation to match the VE - JV1 to the setting of the Temporary Area in the Voice Expansion mode when the setting of the VE - JV1 differs from that of the Temporary Area in the Voice Expansion mode.

V - EXP → MIDI (Voice Expansion → MIDI)

Transfer the Parameter data on the Voice Expansion Board to a sequencer or a MIDI device that can record bulk data.

● Protect

The Internal Protect setting prevents internal memory from accidentally being overwritten.

The Exclusive Protect setting prevents user memory (internal / DATA card) from being overwritten by exclusive data from MIDI IN.

WRITE PROTECT

WRITE	Internal	Exclusive
PROTECT	ON	OFF

Internal *Internal protect* ON/OFF

When this is ON, internal memory protect is enabled. If you wish to write Patch or Tone data from the temporary area or from a card into internal memory, this must be set to OFF. When the power is turned on, this setting will be ON.

Exclusive *Exclusive protect* ON/OFF

When this is ON, exclusive protect is enabled. If you wish to overwrite the contents of user memory (internal / DATA card) with exclusive data from MIDI IN, this must be set to OFF. If user memory contains important data, you should set this to ON. When the power is turned on, this setting will be OFF.

* When Exclusive Protect is OFF, exclusive messages will overwrite internal memory even if Internal Protect is ON.

[Procedure]

Use [INC]/[DEC] or parameter sliders 1 or 2 to turn each protect setting ON or OFF.



430



Chapter 4

***USING A VOICE
EXPANSION BOARD***

Chapter 4

1. Using a Voice Expansion Board

■ Using a Voice Expansion Board

● Modes

Voice Expansion Play Mode (P.105, 106)

To select the Voice Expansion Play mode, press the Mode Selection button [V - EXP] and make sure that the indicator is lit. This mode allows you to play the Voice Expansion Board from the JV - 90's keyboard (when the V - EXP MIDI IN Selector Switch is set to INT). The JV - 90 retains the previous mode in memory, which can be determined by the indicator of the relevant Mode Selector button; [PERFORMANCE], [PATCH] or [RHYTHM]. The JV - 90's sound module is played in this mode with the MIDI messages received through MIDI IN.

Voice Expansion Edit Mode (P.113)

To select the Voice Expansion Edit mode, press [EDIT] in the Voice Expansion Play mode. This mode allows you to edit various parameters on the Voice Expansion Board.

● Two Types of Voice Expansion Boards

There are two types of Voice Expansion Boards; the VE - GS1 and VE - JV1. JV - 90 operation will depend on which you install.

● Structure of the VE - GS1

The VE - GS1 has 16 Parts and one Tone can be assigned to each Part. Part MIDI channels 1—16 are available (Page 108).

- * When you play the Voice Expansion Board with MIDI, change the position of the V - EXP MIDI IN Selector switch on the rear panel of the JV - 90 (depending on the type of performance you want). (See page 104.)

When a Voice Expansion Board is not installed, pressing [V - EXP] in MODE will cause the screen to show the following display.

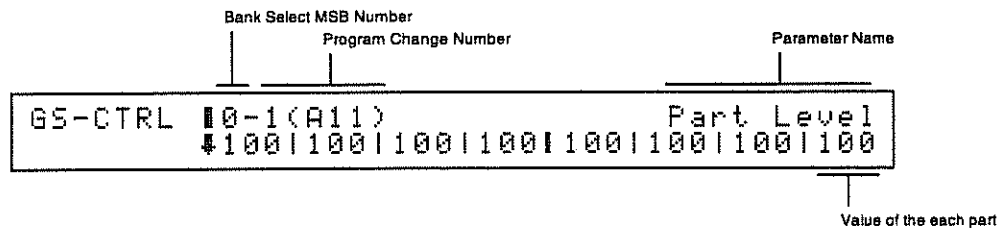

If so, the parameters of a Roland GS sound module connected via MIDI can be edited on the JV - 90's screen.

● Structure of the VE - JV1

The VE - JV1 consists of exactly the same structure as the JV - 90's internal sound module when the Performance Mode is set to the factory defaults. It has 7 Parts and 1 Rhythm Part, and a Patch can be assigned to each Part (1 - 7) and a Rhythm Set to the Rhythm Part.

Exactly the same Performance Parameters, Patch Parameters, Rhythm Sets and Waveforms as the JV - 90 are provided in the VE - JV1, and the control channel of the VE - JV1 is set to 16.

The VE - JV1 can also receive/transmit bulk data as System Exclusive messages. Therefore, the performance data edited on the JV - 90 can be transferred to the VE - JV1 as bulk data. (See page 98.)

● VE - GS1 Maximum Polyphony

The VE - GS1 can play up to 28 notes simultaneously. However, depending on the number of voices (*) used for the Tone assigned to the Part, the number of notes to be played simultaneously may be reduced. (Some Tones in VE - GS1 use two voices to create the most realistic result. This, however, reduces the maximum polyphony to 14 notes.)

- * To find the number of voices used for the Tones of the VE - GS1, refer to the "Tone List" supplied with the VE - GS1. All the Tones of the JV - 90 use one voice only.

● The VE - GS1's Sound Parameters are Part Parameters

The sound parameters of the VE - GS1 should all be set for a Part. None of them apply to a Tone. That is, if you change the values of a parameter then change Tones assigned to the Part, the edited parameter value will be applied to the new Tone.

● When the value in the screen differs from that on the Voice Expansion Board

If it applies to the following cases, you can change the values indicated in the screen using the buttons or sliders on the JV - 90. This, however, does not change the actual value set on the Voice Expansion Board.

- If you set a parameter when the V - EXP MIDI IN Selector Switch on the rear of the unit is set to EXT
→ Change it to the INT position.
- If you set the parameter in the Part where the Local Control Switch is set to OFF
→ Set the Local Control Switch to ON. (See page 106.)

Either send the data to the Voice Expansion Board using the bulk command in the Write mode, or send the data of the Voice Expansion Board to the JV - 90. (Page 98)

When the GM System On messages are sent to the VE - GS1 (such as when you play the VE - GS1 with GM score data), the VE - GS1 works as a GM sound module. The VE - GS1, however, does not recognize NRPN or Bank(CC0) messages. This may cause some parameters to be unavailable for editing.

If this happens, follow "Resetting the VE - GS1" procedure.

When a Bank Select message whose value is other than 0 is sent to the VE - GS1, the Part that receives the Bank Select message may be muted. If this happens, set an appropriate Bank Select number (or a Program Change number) using the [BANK] and [NUMBER] buttons in a PATCH GROUP.

Resetting the VE - GS1

Press [COMMON] in the Voice Expansion Edit mode, then press [ENTER]. This will reset the VE - GS1 to the original factory settings.

● V - EXP MIDI IN Selector Switch

Ordinarily, set the V - EXP MIDI IN Selector Switch to INT.

When the V - EXP MIDI IN Selector Switch is set to INT, the MIDI messages received at the V - EXP MIDI IN will be ignored.

When the Part on the JV - 90, and that on the Voice Expansion Board are set to the same MIDI receive channel number, two sounds will be mixed. If so, parameters in the JV - 90's sound module and in the Voice Expansion Board may be altered by messages received through MIDI IN.

When should I set the V - EXP MIDI IN Selector Switch to EXT ?

If you wish to use more than 16 Parts in ensemble performances, set the V - EXP MIDI IN Selector Switch to EXT and use both the V - EXP MIDI IN and MIDI IN sockets. Then the Voice Expansion Board ignores any messages received through the MIDI IN Selector Switch and is played with the messages received through the V - EXP MIDI IN Selector Switch to the EXT position, the Voice Expansion Board can be used as a sound module completely separate from the JV - 90.

- * When the V - EXP MIDI IN Selector Switch is set to EXT, no sound on the Voice Expansion Board can be played from the JV - 90's keyboard (so, it should be normally set to INT).
- * When the V - EXP MIDI IN Selector Switch is set to EXT, pressing V - EXP in the Mode Selector buttons will show the following message in the screen:

Warning!!

Then it will change to the normal screen of the Voice Expansion Play Mode. Here, no message from the JV - 90 will be transmitted to the Voice Expansion Board and therefore the values edited in the Voice Expansion Edit Mode will not affect the Voice Expansion Board.

2. Using the VE - JV1 Voice Expansion Board

● Select the Voice Expansion Play Mode

Press [V - EXP] in the Mode buttons, and the following display appears showing that the Voice Expansion mode is selected.

```
U-EXP|A.Piano 1 :           Part Level  
A11  ↓127|127|127|127|127|127|127|127|127
```

● How to select the Part to be played from the keyboard

In the Voice Expansion Play mode, the Part indicated with the cursor can be played from the keyboard. To change Parts to be played, move the cursor with [◀]/[▶].

● How to change sounds in a Part

The upper line of the screen shows the name of the Patch assigned to the Part currently selected. To select a new sound to be assigned to the Part, use the PATCH GROUP button.

Display	Combination of buttons	Patch to be selected	Display	Combination of buttons	Patch to be selected
A	PRESET - A	JV - 90 PRESET A	E	USER - INT	Factory preset data of the JV - 90 USER INTERNAL
B	PRESET - B	JV - 90 PRESET B	F	USER - CARD	Data of PN - JV80 - 04
C	PRESET - C	JV - 90 PRESET C	G	USER - PCM - A	Compatible data of JV - 80 PRESET A
D	PRESET - D	JV - 90 PRESET D	H	USER - PCM - B	Compatible data of JV - 80 PRESET B

* No data can be stored in the USER INTERNAL or USER CARD area on the VE - JV1.

* PN - JV80 - 04 "RICH SOUND COLLECTION 2".

● How to edit the Sound Parameters of the VE - JV1

Select the sound parameter to be edited by pressing the relevant button in the EDIT PALETTE, then change the value on the screen of the JV - 90. You can change values in the same way as with the VE - GS1 explained on page 108. The contents of the parameters are exactly the same as the JV - 90's sound module. (Page 48)

* If you wish to set all the parameters on the VE - JV1 to the same values as the JV - 90, select the Write Mode, then transfer all the data to the VE - JV1. (Page 98)

* You can change the envelope of the Tone on the VE - JV1 by pressing [TVF/TVA] in the Voice Expansion mode. The envelopes of all four Tones, however, will be changed relatively.

3. Using the VE - GS1 Voice Expansion Board

● Select the Voice Expansion Play Mode

Press [V - EXP] in Mode buttons, and the following display appears showing that the Voice Expansion Play mode is selected.

```
V-EXP | A.Piano 1 :          Part Level  
0-1  ↓ 100 | 100 | 100 | 100 | 100 | 100 | 100 | 100
```

● How to select the Part to be played from the keyboard

In the Voice Expansion Play mode, the Part indicated with the cursor can be played from the keyboard. To change Parts to be played, move the cursor with [◀]/[▶] to the relevant Part. The screen shows the name of the sound of the Part as well as the GS Bank Number and the Program Number.

To play a Part 1—8, press [PART SEL(1—8)] in the EDIT PALETTE and make sure that the indicator is lit. To play a Part from 9—16, press [PART SEL(9—16)].

● Part On/Off(play/mute)

When you play a Part with messages received through MIDI IN, you can turn on (play) or turn off (mute) each Part. When the indicator of the PART SWITCH buttons is lit, the corresponding Part is turned on and therefore will sound. If the indicator is dark, the Part is muted. Pressing the PART SWITCH buttons turns on or off the Part. To turn Parts 9—16 on/off, press [PART SEL(9—16)] and turn on the indicator. To set a Part of 1—8, press [PART SEL(1—8)].

● How to change sounds in a Part

To change the sound assigned to a Part, press [PATCH] in the EDIT PALETTE and call the following display.

```
V-EXP | 01  01  01  01  01  01  01  01  0  
Bnk/Pc | 11  11  11  11  11  11  11  11  1
```

The upper line of the display shows the GS Bank Number and the lower line shows the Program Number. To select a sound on the VE - GS1, use the GS Bank Number and Program Number. When the indicator of [PART SEL(1—8)] in the EDIT PALETTE is lit, the screen shows the Bank Numbers and Program Numbers of Parts 1—8 from left to right. When the indicator of [PART SEL(9—16)] is lit, the screen shows the Bank Numbers and Program Numbers of Parts 9—16.

How to set the Program Numbers

There are three different methods for setting Program Numbers:

1. Move the cursor to the Part where you wish to change sounds using [PART SEL] in the EDIT PALETTE and [◀]/[▶], then set the number with the Parameter Slider that corresponds to the Part number.
 2. Move the cursor to the relevant Part with [◀]/[▶], then set the number with [INC]/[DEC].
 3. Move the cursor to the relevant Part with [◀]/[▶], then specify the Patch Number using V - EXP - [A][B] in the PATCH GROUP buttons and BANK/NUMBER buttons. When you use V - EXP - [A], you can set a Patch Number of 1—64 with BANK/NUMBER buttons, and when you use V - EXP - [B], you can set numbers 65—128.
- * Setting a Patch Number with the Parameter Sliders or [INC]/[DEC] will affect the indicators of BANK and NUMBER buttons in the PATCH GROUP.

How to set the GS Bank Number

To specify a Bank number, move the cursor to the Part where you wish to change Bank numbers using [◀]/[▶]. Then press V - EXP - [BANK LO] in the PATCH GROUP buttons to set a GS Bank number of 0—63, and V - EXP - [BANK HI] to set a GS Bank number of 64—128.

Specify the Bank number as described in "How to set the Program Numbers" (step 1, 2 or 3).

How to set the Rhythm Set

To assign a Rhythm Set to a Part, move the cursor to the Part where you wish to set the Rhythm Set using [◀]/[▶]. Press [V - EXP RHY] in the PATCH GROUP buttons. Select the Rhythm Set to be assigned with BANK and NUMBER buttons. The screen now shows the Program Number of the selected Rhythm Set. At the Part where the Rhythm Set is assigned, "R" is shown instead of the Bank Number.

- * You can assign Rhythm Sets to a maximum of 2 Parts.
- * Part 10 has been factory - designated as the Rhythm Part.

● How to edit the sound parameters of the VE - GS 1

Press the relevant buttons in the EDIT PALETTE to select a sound parameter to be edited, then edit the value on the JV - 90's screen. Press [PART SEL(9—16)] and make sure that the indicator is lit, and you can edit the parameters in Parts 9—16. To edit the parameters in Parts 1—8, press [PART SEL (1—8)]. You can change the values of a parameter using the Parameter Slider that corresponds to the Part Number. You can also edit a parameter using the buttons in FUNCTION.

- * Pressing [▲]/[▼] in the screen of "↑" or "↓" will select pages of other parameters.

The following shows the parameters that can be edited

Parameters that can be edited by using buttons in EDIT PALETTE.

Parameters that can be selected by pressing [LEVEL]:

Part Level 0—127

This adjusts the volume balance of each Part.

Press [LEVEL], then the following parameters can be selected with [▼].

Voice Reserve 0—28 (Page 76)

This sets the minimum number of voices that should be retained for each Part.

- * The maximum number of voices played on the VE - GS1 is 28. Be sure that the total number of voices for all Parts is less than 28.

Part MIDI Channel

This sets the receive channel of a Part and the MIDI transmit channel of the JV - 90's keyboard (in the Voice Expansion Mode).

Parameter that can be selected by pressing [PAN]:

Part Pan L64—0—63R/RND

This adjusts the sound position (within the stereo positioning) of each Part.

- * In some Patches, a small amount of sound may be heard from the opposite speaker even with pan settings of full left (or right).
- * In the Rhythm Set, the Pan is set for each Rhythm Tone. That is, if you change the pan setting of a Part where the Rhythm Set is assigned, the sound position of the entire Rhythm Set will move.
- * When the Part Pan is set to 63R, pressing [INC] will select "RND" that moves the sound positions to the right and left at random.

Parameter that can be selected by pressing [TUNE]:

Part Coarse Tune -24—+24

This adjusts the pitch of each Part in semi - tone steps.

When [TUNE] is pressed, the following parameter can be selected with [DOWN].

Part Fine Tune -50—+50

This adjusts the pitch of each Part in steps of 1/100 of a semi - tone.

Parameter that can be called by pressing [PATCH]:

Patch Select

This specifies the Tone and Rhythm Set assigned to each Part. The upper line of the screen shows the Bank Number of the Tone and the lower line shows the Program Number.

Parameters that can be selected by pressing [TVF/TVA]:

TVF Cutoff Freq. -50—+50

This controls the cutoff frequencies of the TVF.

When [TVF/TVA] is pressed, the following parameters can be selected with [▲]/[▼].

TVF Resonance -50—+50

This controls how the harmonics around the cutoff frequency will be emphasized.

TVF - TVA Env Attack -50—+50

This controls the time needed for the volume and cutoff frequency to reach a certain level.

TVF - TVA Env Decay -50—+50

This determines the time needed for the sound to reach the sustain level after the attack time has elapsed.

TVF - TVA Env Release -50—+50

This determines the time needed for the sound to fall to the minimum level.

Parameter that can be selected by pressing [REVERB]:

Reverb Send Level 0—127

This adjusts the depth of the reverb effect.

Parameter that can be selected by pressing [CHORUS]:

Chorus Send Level 0—127

This adjusts the depth of the chorus effect.

Parameters that can be called by pressing [VIBRATO]:

Vibrato Rate -50—+50

This controls the rate of the vibrato effect.

When [VIBRATO] is pressed, the following parameters can be selected with [▲]/[▼].

Vibrato Depth -50—+50

This controls the depth of the vibrato effect.

Vibrato Delay -50—+50

This determines the time needed for the vibrato effect to start working.

Parameters that can be edited by pressing buttons in FUNCTION:

- * What you set here will be common to all the Parts.

Parameters that can be selected by pressing [EFFECT]:

Reverb Type

Chorus Type

These allow you to select a reverb and a chorus you like from 8 different types for each.

<Reverb Types>

Rooms 1 - 3	Sharp and spacious reverberations are obtained.
Halls 1 and 2	Longer and deeper reverbs than those provided by the Room settings.
Plate	This simulates a plate echo (the reverb that uses the vibrations on a metal plate).
Delay	A conventional delay effect.
Panning Delay	Special delay where the sound moves to the right and left. Especially effective with a stereo output.

<Chorus Types>

Choruses 1 - 4	These are standard chorus effects.
Feedback Chorus	A chorus that creates a flanger - like effect. This makes the sound softer.
Flanger	Creates the sonic illusion of a jet plane ascending and descending.
Short Delay	A delay with a short delay time.
Short Delay (FB)	Short delays repeated many times.

Parameters that can be selected by pressing [PGM CHANGE]:

Tx - Ch (*Transmit Channel*) 1—16

This sets the MIDI channel on which the Program Change messages are transmitted.

P.C - No (*Program Number*) 001/All—128/B88

This selects the Program Number to be transmitted on the Tx - Ch.

The screen shows the Program Change number in the form of "Program Number/Group - Bank - Number". The indicators of PATCH GROUP BANK and NUMBER button will light according to the selected Program Number.

- * When the cursor is at the position of a Program Number, you can set the Number directly using numbers (1—128). BANK [1]—[8] corresponds to 1—8, and NUMBER [1] and [2] correspond to 9 and 0. Simply enter the Program Number you wish then press [ENTER] and it will be transmitted.

```

TRANSMIT | Tx-Ch | P.C-No | Bnk-MSB | Bnk-LSB
P.C      |      | 11001/All |      01 |      0

```

When the cursor is at the position of Group/Bank/Number, you can specify the Program Change Number using PATCH GROUP/BANK/NUMBER.

Bnk - MSB/Bnk - LSB (GS Bank Number) 000—127 each

These set the MSB (the value of Control Change 0) and LSB (the value of Control Change 32) of the GS Bank Number to be transmitted on the Tx - Ch.

- * The Bank Number will be sent together with the Program Number when [ENTER] is pressed.

Parameters that can be selected by pressing [TUNE]:

Tune (Master Tune) 415.3—466.2Hz

This controls the pitch of the Voice Expansion Board. The values are the frequencies of the A4 key.

Transpose ON/OFF -36—+36

This transposes the performance information (in semi - tone steps) sent from the keyboard controller to the Voice Expansion Board. The left side of " | " determines whether to use the Transpose function (ON) or not (OFF), while the right side of " | " sets the amount of transposition.

LCD (LCD Contrast) 0—10

This adjusts the contrast of the display.

JV - LEVEL (JV Master Level) 0—127

This adjusts the overall output level of the internal sound module.

EX - LEVEL (V - EXP Master Level) 0—127

This adjusts the volume level of the Voice Expansion Board. The value you set here will be invalid if the V - EXP MIDI IN Selector on the rear of the JV - 90 is set to EXT.

Key - Shift (Master Key Shift) -24—+24

This shifts the pitch of the Voice Expansion Board in semi - tone steps.

Pan (Master Pan) L63—0—R63

This adjusts the overall pan setting (sound position) for the output of the Voice Expansion Board.

Parameters that can be selected by pressing [CONTROL]:

You can control the parameters assigned to foot pedals 1 and 2 connected to the Pedal Jacks 1 and 2, and the C1 slider.

Mode (Output Mode) OFF/INT/MIDI/I+M

This determines which sound module (MIDI device) should be controlled with the pedals or the C1 slider. The INT mode sends the messages only to the VE - GS1. The MIDI mode sends messages to only the MIDI OUT on the rear of the unit. In the I+M mode, messages are sent to both the VE - GS1 and MIDI OUT. When it is set to OFF, neither the VE - GS1 or external MIDI device can be controlled using the slider or pedals.

Assign CC0—CC95/AFTERTOUC/BEND - UP/BEND - DOWN/PROG - UP/PROG - DOWN

This determines the parameter to be controlled with the pedal or C1 slider. When CC0—CC95 is selected, the value of MIDI Control Change number 0—95 is affected. When AFTERTOUC is selected, the value of Aftertouch is affected. When BEND - UP/BEND - DOWN is selected, the up and down value of the Pitch Bend is affected. When PROG - UP/PROG - DOWN is selected, the value of the Program Number increases or decreases. The value shown in the screen () represents the current value of the pedal/C1 slider.

STANDARD/REVERSE for Pedal 1, Pedal 2 and Hold

This selects Standard or Reverse polarity for the JV - 90 in accordance with the polarity of the pedal switch connected to the Pedal Jack 1/2 or Hold Pedal Jack. When you use a Roland Pedal Switch (e.g. DP - 2), set polarity to STANDARD.

When you use a pedal switch that has opposite polarity (*), set to REVERSE.

- * Switch polarity may be the problem when the sound is sustained, even without pressing the pedal, when a pedal is connected to the Hold Pedal Jack.

Thresh (Threshold Level) 0 - 127

This sets the threshold level where the aftertouch effect starts working. That is, the aftertouch effect does not work unless the aftertouch value exceeds the threshold level. When the Threshold is set to 127, no aftertouch effect can be obtained.

Parameters that can be selected by pressing [MIDI]:

Move the cursor to any Part you like then press MIDI, and you can select the parameter setting display for MIDI in that Part.

This selects whether to send each MIDI message (ON) or not (OFF).

The MIDI messages are:

P.C. : Program Change

C.C. : Control Change

Vol : Volume

Bend : *Pitch Bender*

Mod : *Modulation*

Aft : *Aftertouch*

When [RX PART SWITCH] is pressed :

This selects whether or not to recognize the MIDI messages received through MIDI IN for each Part in JV - 90's internal sound module or Voice Expansion Board. Move the cursor with [◀]/[▶] to select a Part, then select 1 or 0 with [INC]/[DEC] (1 is to recognize and 0 is to ignore). The Part where 0 is set will be muted.

- * When the JV - 90 is set to the Performance Mode, changing the value also changes the MIDI Receive Switch (Page 32) automatically.
- * When the JV - 90 is set to the Patch mode, the Part of the Voice Expansion Board (Page 42) that has the same receive channel as the receive channel (Page 108) of the Patch is shown with an arrow "↓".
- * When the V - EXP MIDI IN Selector Switch is set to EXT, the Voice Expansion Board will be played with the MIDI messages received on the V - EXP MIDI IN. The MIDI messages received through MIDI IN, however, will be ignored by the Voice Expansion Board. (Page 104)

Parameters that can be edited by pressing [EDIT] in FUNCTION:

To edit parameters in a specified Part, move the cursor to the relevant Part in the Voice Expansion Play mode, then press [EDIT] in FUNCTION (Voice Expansion Edit Mode). In the Voice Expansion Edit mode, you can select the desired parameter by pressing the corresponding FUNCTION button.

● Other Editing Procedures

Parameters that can be selected by pressing [CONTROL]

Assign (*Key Assign*) POLY/MONO

This selects whether to play each Part polyphonically (POLY) or monophonically (MONO).

Bend Range (*Bender Range*) 0—24

This sets the maximum level of the pitch change caused by the pitch bend lever. It can be set up to 2 octaves in semi tone steps.

Mod - Depth (*Modulation Depth*) 0—127

This sets the depth of the modulation (e.g. vibrato effect) caused by the modulation lever.

DEPTH *Velocity sensitivity depth* 0—127

As the Velocity Sensitivity Depth is increased, changes in playing dynamics will have a greater effect on volume. With a setting of 0, playing dynamics will have no effect on volume.

OFFSET *Velocity sensitivity offset* 0—127

This parameter determines the velocity at which volume changes will result. As this setting is increased above 64, the volume will change for softly played notes. As this setting is decreased below 64, the volume will change for strongly played notes.

Parameters that can be selected by pressing [TVA/TVF]

TVF Cutoff Freq. (TVF Cutoff Frequency) -50—+50

This determines the cutoff frequency (that cuts off the harmonics in a sound).

TVF Resonance -50—+50

This sets how much the harmonics around the cutoff frequency will be emphasized.

TVF - TVA Attack (Envelope Attack) -50—+50

This determines the time needed for the volume and cutoff frequency to reach a certain level.

TVF - TVA Decay (Envelope Decay) -50—+50

This determines the time needed for the sound to reach the sustain level.

TVF - TVA Release (Envelope Release) -50—+50

This determines the time needed for the sound to fade away.

Parameters that can be selected by pressing [PITCH]:

Coarse Tune (Part Coarse Tune) -24—+24

This adjusts the pitch of each Part in semi - tone steps.

Fine Tune (Part Fine Tune) -100—+100

This adjusts the pitch of each Part in steps of 1/100 of a semi - tone.

Parameters accessed by [EFFECT]

These are the parameters related to chorus and reverb. Chorus and reverb give depth to the sound or create a spacious stereo effect.

- * The effect unit settings of VE - GS1 are common to all Parts. The depth of the effect for each Part will depend on the Chorus/Reverb Send Level parameters (P.109), which are set independently for each Part.

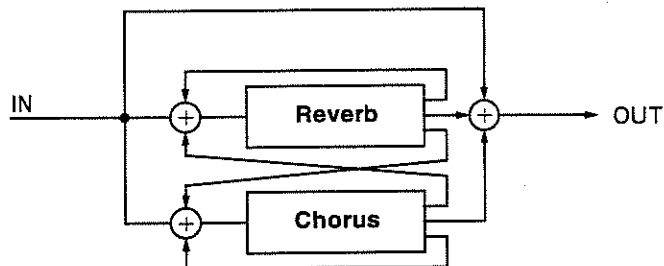

U-EXP	CHR	LPF	LVL	ITIM	FB	SENI	---	---
REVERB	4	0	40	40	0	0	---	---

CHR Reverb character 0—7

This parameter determines the type of reverb.

LPF *Reverb pre LPF* 0—7

This parameter sets the LPF (low pass filter) placed before the reverb.

LVL *Reverb level* 0—127

This parameter sets the level (volume) of the reverberant sound.

TIM *Reverb time* 0—127

When the reverb type is ROOM1—PLATE, this parameter sets the reverb time. When the reverb type is DELAY/PAN - DELAY, this parameter sets the delay time.

FB *Delay feedback* 0—127

When the reverb type is DELAY, this parameter sets the level at which the delayed sound is fed back into the delay.

SEN *Reverb send level* 0—127

This parameter sets the level at which the reverb output is sent to the chorus.

```
U-EXP  ↑LPFILVLI  FBIDELIRATIDEP|SENI  
CHORUS  ↓  0| 40|  8| 50|  3| 13|  0|---
```

LPF *Chorus pre LPF* 0—7

This parameter sets the LPF (low pass filter) placed before the chorus.

LVL *Chorus level* 0—127

This parameter sets the level (volume) of the chorused sound.

FB *Chorus feedback* 0—127

This parameter sets the level at which the chorused sound is fed back into the chorus.

DEL *Chorus delay* 0—127

This parameter sets the delay time.

RAT *Chorus rate* 0—127

This parameter sets the modulation speed of the chorus.

DEP *Chorus depth* 0—127

This parameter sets the modulation depth of the chorus.

SEN *Chorus send level* 0—127

This parameter sets the level at which the chorus output is sent to the reverb.

Chapter 5

REFERENCE

Chapter 5

1. Error Messages

When operations have been incorrectly executed, or when some unexpected condition arises, an error message will be displayed. Check the displayed error message and implement the suggested solution (or solutions) in this section. All the messages listed below are displayed for about 1.5 seconds, after which the screen returns to the previous display.

● Internal RAM Write Protect

Problem: The internal memory write-protect function is on and data cannot be written or stored.

Solution: After this message is displayed, the screen automatically switches to the write-protect display. Set the Internal protect function to OFF from this display.

● Internal RAM Read Error

Problem: The data of the internal memory has somehow been destroyed.

Solution: Consult with your nearest Roland Service Station.

● Internal Battery Low

Problem: The internal backup battery has run down.

Solution: Consult with your nearest Roland Service Station.

● DATA Card Not Ready

Problem: The DATA card has not been inserted into the DATA card slot or has not been inserted correctly.

Solution: Insert the DATA card correctly and securely.

● DATA Card Not Properly Formatted

Problem: The DATA card inserted has not been properly formatted for use with the JV-90 or JV-80 series.

Solution: Format the card from the Write mode (P.95).

● DATA Card Write Protect

Problem: The protect switch of the DATA card is on and data cannot be stored on the card.

Solution: Set the protect switch of the DATA card to off (P.88), then perform the desired operation again.

● DATA Card Read Error

Problem: The data of the DATA card has somehow been destroyed.

Solution: Consult with your nearest Roland Service Station.

● DATA Card Battery Low

Problem: The DATA card backup battery has run down.

Solution: Transfer the data to another DATA card, then replace the battery in the original card.

● PCM Card Not Ready

Problem: The PCM card has not been inserted into the PCM card slot or has not been inserted correctly.

Solution: Insert the PCM card correctly and securely.

● PCM Card Not Properly Formatted

Problem: A PCM card not designed for use with the JV-90 has been inserted into the PCM card slot.

Solution: Use only a proper PCM card.

● MIDI Communication Error

Problem: Either an excessive amount of data was received at once, or the active sensing function was cut off.

Solution: Do not attempt to continuously transmit large amounts of data (like program change messages) that require processing on reception and, hence, take more time than usual. Also make sure that all MIDI cables are connected correctly.

● **BULK DUMP: MIDI Buffer Full**

Problem: Excessive data has been transmitted at once by the bulk dump function.

Solution: Make adjustments to the exclusive data so that it is sent in several "packets" of smaller amounts.

● **BULK DUMP: Check Sum Error**

Problem: The checksum value of the bulk dump is incorrect.

Solution: Correct the exclusive data.

● **BULK DUMP: DATA Card Not Ready**

Problem: A DATA card has not been inserted and the data received by the bulk dump function cannot be written or stored.

Solution: Insert a DATA card correctly and securely into the DATA card slot.

● **BULK DUMP: Improper DATA Card**

Problem: A DATA card not properly formatted for use with the JV-90 or JV-80 series has been inserted and the data received by bulk dump cannot be written or stored.

Solution: After formatting the DATA card from the Write mode (P.95), perform the operation again.

● **BULK DUMP: DATA Card Write Protect**

Problem: The protect switch of the DATA card is on and data received during execution of the bulk dump function could not be written or stored.

Solution: Set the protect switch of the DATA card to off (P.88), then perform the operation again.

● **Warning !!** **V-EXP Parameters Would Be Ignored.**

Problem: You cannot play or edit the Voice Expansion Board in the V-EXP mode because the V-EXP Selector Switch is set to the EXT position.

Solution: If you wish to play or edit in the V-EXP mode, change the V-EXP MIDI IN Selector Switch to the INT position.

● **Please Set V-EXP MIDI IN Selector INT.**

Problem: You cannot transfer data between the JV-90 and the Voice Expansion Board because V-EXP MIDI IN Selector Switch is set to the EXT position.

Solution: Set the V-EXP MIDI IN Selector Switch to the INT position.

2. Troubleshooting

Check through the following situations and conditions when your JV-90 fails to operate properly.

Synthesizer Sound Module

No sound

- Check that the JV-90, amplifier and mixer are all turned on.
- Check that all the devices are connected correctly and securely.
- Check that the connecting cables are not defective.
- Check whether the sound is output through a connected set of headphones. If you can hear the sound normally through the headphones, the connected device or cable are probably the cause of the problem.
- Check that the volume of the amplifier, mixer or external MIDI sound source are set to suitable levels.
- Check that the volume of JV-90 is set to a suitable level.

For the internal sound source, check the following:

- The position of the master volume
- The internal level value which is set for each part of a Performance
- The Part level value which is set for the Part of a Performance
- The Patch level value which is set for a Patch
- TVA level value which is set for the Tone of a Patch or a Rhythm Tone
- The position of the pedal or slider when CC7/VOLUME is assigned to Pedal 1/2 or C1
- The value of the volume data received via MIDI IN

For connected Synthesizer MIDI devices, check the following:

- The transmit volume setting which is made for the transmit zone of a Performance
- The position of the pedal or slider when CC7/VOLUME is assigned to Pedal 1/2 or C1
- Check that the local switch is OFF:
 - The setting of the local switch in the system common parameters
 - The setting of the local switch which is set for the internal zone of a Performance
 - When the Key Mode is set to Single, only the Part indicated with the cursor will be played. That is, no other Part cannot be played by the Keyboard even if the Local Switch is set to ON.

- Check that the receive switch which is set for the Part of a Performance is on.
- Check that the transmit switch which is set for the transmit zone of a Performance is on.
- Check that the Patch transmit channel of the system parameters is on.
- Check that the Tone switch which is set for the Tone of a Patch is on.
- Check that the range of the zone has been properly set:
 - The key range value which is set for the transmit or internal zone, when the key mode of the Performance is set to zone
 - Some Data Card on the market have the Keyboard range varying from C2 to C7.
- Check that the MIDI channel has been set properly:
 - The Patch transmit/receive channel value which is set in the system common parameters
 - Transmit channel value which is set by the transmit zone of the Performance
 - Receive channel value which is set for the Part of a Performance
- Sound may not be produced if: 1) the cutoff is set to 0 and the TVF filter type for the Tone of a Patch or a Rhythm Tone is set to LPF, or 2) the cutoff is set to 127 and the filter type is set to HPF.

Check the following:

- TVF cutoff value
- TVF envelope depth
- The velocity sensitivity value and the key follow setting of the TVF envelope
- The level setting of TVF envelope
- The depth setting and the controller position when the modulation/aftertouch/expression control parameter is set to cutoff
- The value of Velocity Range when the Velocity Switch of the Patch is set to ON.

- Check that the TVA level of the Patch Tone or Rhythm Tone is set to 0.

Check the following:

- Dry level value which is set by the effect send
- TVA level value
- The velocity sensitivity value and the key follow setting of the TVA envelope
- The level setting of TVA envelope
- The depth setting and the controller position when the modulation/aftertouch/expression control parameter is set to level
- The Tone delay time value
- The value of Velocity Range when the Velocity Switch of the Patch is set to ON.

- The sound range may be limited depending on the wave selected.

Check the following:

- Transpose value of the system common parameters
- Transpose value which is set for the internal zone of a Performance
- Coarse tune value which is set for the Part of a Performance
- Coarse tune value which is set for the Tone of a Patch
- Coarse tune value which is set for the Rhythm Tone

■ Volume cannot be controlled

- Check that either pedal 1/2 or C1 is assigned to CC7/VOLUME.
- Check that the receiving switch for the volume is not off.

Check the following:

- The receive volume setting which is set by MIDI receive in the system common parameters
- The receive volume setting which is set for the Part of a Performance
- The volume setting which is set for the pedal of the Patch Tone
- The volume is not transmitted even though the value of the transmit volume of the transmit zone is changed in the Performance Edit mode.

■ Dynamic changes in the sound do not respond correctly or as you expect them to

- Check the velocity sensitivity settings:
 - The value of the velocity curve/sensitivity and maximum velocity, which are set in transmit/internal zone of the Performance

- The value of the TVA velocity curve/sensitivity, which are set for the Rhythm Tone of a Patch.

■ The sound is distorted

- Check the levels of the amplifier and mixer and the master volume of the JV-90 are set properly.
- When the Part level parameter of a Performance is set too high, the sound sometimes may be distorted.
- When the TVA level or the resonance value set for a Patch Tone or Rhythm Tone is set too high, the sound sometimes may be distorted.

■ The pitch is wrong or does not change

- Check that the tune settings are correct:

- The master tune/transpose values of the system parameters
- The transpose value set for the internal zone of a Performance
- The coarse tune/fine tune values set for the Part of a Performance
- The coarse tune/fine tune/random pitch values set for the Tone of a Patch or a Rhythm Tone
- The pitch key follow value set for the Tone of a Patch
- The pitch envelope value set for the Tone of a Patch or a Rhythm Tone
- The tuning value of the external MIDI sound source
- The setting of the Scale Tune.

- Check that the pitch bender has not been moved

Check the following:

- The position of the bender lever
- The position of pedals 1/2 and C1 when the assignment of pedal 1/2 and C1 are set to BEND-UP/BEND-DOWN
- The pitch bend value received via MIDI IN
- The bender range value which is set for the Patch
- The bender range value which is set for the Rhythm Tone
- The bender range value of the external MIDI sound source

- Check that the receiving switch of the pitch bender is OFF.

Check the following:

- The bender setting which is set by the transmit/receive MIDI functions of the system common parameters
- The bender range value which is set for the Patch
- The bender range value which is set for the Rhythm Tone
- The bender range value/receiving switch of the external MIDI sound source

- Check that the effects and LFO are correctly set

Check the following:

- The chorus value which is set for the Performance/Patch
- The analog feel value which is set for the Patch
- The switch/depth value of FXM which is set for the Tone of a Patch
- The pitch LFO depth value which is set for the Tone of a Patch
- The depth value and the controller position of the modulation/aftertouch/expression control which is set for the Tone of a Patch, when the parameter is set to pitch LFO

- It may happen that the sounding pitch range is limited, or that a Tone doesn't deviate from a certain pitch range, or that the tuning sounds off, depending on the selected wave.

■ The controllers do not work

- Check the mode/assign settings of pedals 1/2 and C1, which are set in the system common parameters.

- Check the transmission/receiving switch of the controller.

Check the following:

- The MIDI transmit/receive settings made in the system common parameters
- The receive volume/hold 1 settings made for the Part of a Performance
- The volume/hold 1 settings made for the pedal of the Tone of a Patch

- Check the modulation/aftertouch/expression control settings made for the Tone of a Patch. The effect is not applied when the parameter is set to off or the depth is set to 0.

- The Threshold Level of the Aftertouch should be set to an appropriate value. If it is set to 127 no aftertouch effect can be obtained.

■ The sound color does not change or program change messages are not sent

- Check that the switches which allow sending and receiving of program change messages are not set to OFF:

- The program change setting for MIDI transmit/receive which is set in the system common parameters
- The transmit program change value which is set for the transmit zone of a Performance
- The receive program change value which is set for the Part of a Performance

- Check that the MIDI channel settings are correct:

- The control channel value which is set in the system common parameters
- The Patch transmit/receive channel value which is set in the system common parameters
- The transmit channel value which is set for the transmit zone of a Performance
- The receive channel value which is set for the Part of a Performance

- The layer/zone key mode and the single key mode of a Performance may have different settings for the program change to be transmitted and the MIDI channel.

- When the Patch select display is selected in the Performance Play mode, the Performance cannot be changed.

- Check that the Edit mode has not been selected:

- Changing Performances or receiving program changes is not possible in the Performance Edit mode.
- Changing Patches or receiving program changes is not possible in the Patch Edit mode.
- Changing Rhythms or receiving program changes is not possible in the Rhythm Edit mode.
- From the Performance Edit mode, program change messages cannot be transmitted even though the value of the transmit program change of the transmit zone has been changed.

■ The effects do not work

- Check that the effect switch is on:

- The chorus/reverb switch on the front panel
- The chorus/reverb switch setting which is made for the Part of a Performance

- Check that the setting of the Performance and the effect of a Patch have been made correctly. The effect is not applied when the chorus/reverb level is set to 0.

-
- Check that the setting of the Patch and Rhythm Tone have been made correctly. The effect is not applied when the chorus/reverb send, which is set by the effect send parameter, is set to 0.

■ Portamento does not work

- Check that the portamento switch, which is set for the Patch, is on.
- When the portamento mode for the Patch is set to legato, portamento is not applied unless you actually play the keyboard with legato technique; that is, holding down one key and not releasing it until after the next key has been pressed.
- Portamento is not applied to Rhythm Tones.

■ The sound is muted

- The maximum Polyphony of the JV-90 is twenty-eight. Decrease the number of Tones you are using or adjust the Partial reserve.
- When the key assign parameter of the Patch is set to solo, only a single Tone sounds even when several keys are played.
- If the mute group of a Rhythm Tone is on, the sound which has been sounding is muted when another sound from the same group is played.

■ The Tone of a Patch cannot be edited as intended

- Check that the condition of the Tone select and the Tone number to be edited match.
- The sound doesn't change when editing a Tone whose Tone switch has been turned off.

■ The Rhythm cannot be edited as intended

- Check that the key which is being edited and the sounding key match. The key to be edited isn't affected by the note data received via MIDI IN.

- No sound results when editing a Tone whose Tone switch has been turned off.

■ Card cannot be used

- Cards which have not been formatted for use with the JV-90 or JV - 80 series cannot be used. Format the DATA card by transferring the internal data to the card (the card will automatically be formatted).
- PCM cards which have not been designed for use with the JV-90 or JV - 80 series cannot be used.

■ Data cannot be transferred by MIDI exclusive messages

- Check that the receive exclusive switch, which is set in the system common parameters, is OFF.
- Check that the unit number, which is set in the system common parameters, is correct. Match it to the unit number of the connected device.
- The temporary data will not be changed, even though the data is transferred by exclusive messages to internal memory or DATA card. Transfer to the temporary area or switch the Performance/Patch by program change after transferring the data by exclusive message.
- Check that a DATA card has been inserted. Data cannot be stored on the DATA card if it has not been properly inserted.
- Check that the DATA card has been formatted for use with the JV-90 or JV - 80 series. Data cannot be stored on the DATA card if it has not been properly formatted for the JV-90 or JV - 80 series.
- Check that the write-protect switch is ON. When transferring data to either the internal memory or DATA card, the data cannot be written unless the corresponding write-protect switch is set to off.

Voice Expansion Board

■ No sound is heard

- Check if the volume is set too low.
- Check the position of the Master Volume.
- Check the value of the Part Level.
- Check the positions of the pedal and slider when CC7/VOLUME are assigned to Pedal 1/2 and C1.
- Check the value of the Volume information from the MIDI IN.
- Check if the level of the V-EXP system common parameter is set too low.
- Check if the MIDI Receive switch is turned to OFF.
- Check if the Receive Volume set with the Receive MIDI is turned OFF.
- When the Cutoff is set to -50, no sound may be heard.
- Check the setting of the Velocity Sens.
- Check the value of the Velocity Sens Depth.
- Check the value of the Velocity Sens Offset.
- Some Patches or Rhythm Sets have limited sound range to be played.
- Check the Transpose value of the V-EXP system common parameter.
- Check the value of the Coarse Tune.
- Check if you have selected the Bank where no Patch is assigned.

■ Pitch is strange/Pitch does not change

- Check if the Tune is correctly set.
- Check the values of the Master Tune/Transpose of the V-EXP system common parameters.
- Check the values of Coarse Tune/Fine Tune.
- Check if the Pitch Bender has been operated.
- Check the positions of the Pedal 1/2 and C1 when the Pedal 1/2 and C1 assignment is BEND-UP/BEND-DOWN.
- Check the value of the Bender Range.
- Check if the Receive Switch of the Pitch Bender is set to OFF.
- Check if the Bender's receive switch set with the Receive MIDI is turned OFF.
- Check if the Effect or Vibrato is correctly set.
- Check the value of the Chorus Depth.
- Check the value of the Vibrato Depth.
- Check the value of the Modulation Depth.
- Owing to the nature of the Wave, it may happen that the pitch is strange or does not change at all in a certain sound range.

■ You cannot call a Patch to be assigned to a Part.

- Check if the MIDI Receive switch is set to OFF.
- Check if the receive switch of the Program Change set with the Receive MIDI is turned to OFF.
- Check if you have selected the Bank where no Patch is assigned.
- The Voice Expansion Edit mode does not allow you to change Patches.

■ No effect is obtained

- Check if the Chorus/Reverb Switch on the front panel of the unit is turned ON.
- Check if the effect is correctly set.
- Check the value of the Chorus/Reverb Send Depth.
- Check the value of the Chorus/Reverb Level.

■ Missing sounds

- The maximum number of voices to be simultaneously played on the expansion sound module is 28. If it exceeds 28 voices, adjust the settings of the Voice Reserve.
- When the Key Assign is set to MONO, only a single note will be played even with more than one Key On.

■ You cannot edit data properly

- When the unit receives the GM System On from MIDI after it is being switched on, some parameters can no longer be edited. If this happens, reset the expansion sound module.
- You cannot edit the Part where the MIDI Receive Switch is set to OFF.
- Check if the Receive Switch of the Control Change or Volume on the Receive MIDI page is set to OFF.
- If the value set with the switches on the panel differs from the value set on the expansion sound module, send the value set on the panel to the sound module again.

3. Waveform List

No.	Wave Name	No.	Wave Name	No.	Wave Name	No.	Wave Name
1	Ac Piano 1	41	SYN VOX 1	81	Rattles	121	REV SN 4
2	SA Rhodes 1	42	SYN VOX 2	82	Tin Wave	122	REV Kick 1
3	SA Rhodes 2	43	Male Ooh	83	Spectrum 1	123	REV Cup
4	E.Piano 1	44	ORG VOX	84	808 SNR 1	124	REV Tom
5	E.Piano 2	45	VOX Noise	85	90's Snare	125	REV Cow Bell
6	Clav 1	46	Soft Pad	86	Piccolo SN	126	REV TAMB
7	Organ 1	47	JP Strings	87	LA Snare	127	REV Conga
8	Jazz Organ	48	Pop Voice	88	Whack Snare	128	REV Maracas
9	Pipe Organ	49	Fine Wine	89	Rim Shot	129	REV Crash 1
10	Nylon GTR	50	Fantasyth	90	Bright Kick	130	REV Brush 1
11	6STR GTR	51	Fanta Bell	91	Verb Kick	131	REV Brush 2
12	GTR HARM	52	ORG Bell	92	Round Kick	132	REV Brush 3
13	Mute GTR 1	53	Agogo	93	808 Kick	133	REV Tom Hi
14	Pop Strat	54	Bottle Hit	94	Closed HAT 1	134	REV Tom Lo
15	Stratus	55	Vibes	95	Closed HAT 2	135	REV Ride
16	SYN GTR	56	Marimba Wave	96	Open HAT 1	136	REV Ped Hat
17	Harp 1	57	Log Drum	97	Crash 1	137	Brush Slap
18	SYN Bass	58	DIGI Bell 1	98	Ride 1	138	Brush Swish
19	Pick Bass	59	DIGI Chime	99	Ride Bell 1	139	Brush Roll
20	E.Bass	60	Steel Drums	100	Power Tom Hi	140	Tom Hi
21	Fretless 1	61	MMM VOX	101	Power Tom Lo	141	Tom Lo
22	Upright BS	62	Spark VOX	102	Cross Stick1	142	Ride 2
23	Slap Bass 1	63	Wave Scan	103	808 Claps	143	Pedal HAT 1
24	Slap & Pop	64	Wire String	104	Cowbell 1	144	Open Triangl
25	Slap Bass 2	65	Lead Wave	105	Tambourine	145	Ac Piano2 pA
26	Slap Bass 3	66	Synth Saw 1	106	Timbale	146	Ac Piano2 pB
27	Flute 1	67	Synth Saw 2	107	CGA Mute Hi	147	Ac Piano2 pC
28	Trumpet 1	68	Synth Saw 3	108	CGA Mute Lo	148	Ac Piano2 fA
29	Trombone 1	69	Synth Square	109	CGA Slap	149	Ac Piano2 fB
30	Harmon Mute1	70	Synth Pulse1	110	Conga Hi	150	Ac Piano2 fC
31	Alto Sax 1	71	Synth Pulse2	111	Conga Lo	151	AcP 2 Thump
32	Tenor Sax 1	72	Triangle	112	Maracas	152	AcP 2 Up TH
33	French 1	73	Sine	113	Cabasa Cut		
34	Blow Pipe	74	ORG Click	114	Cabasa Up		
35	Bottle	75	White Noise	115	Cabasa Down		
36	Trumpet SECT	76	Wind Agogo	116	REV Steel DR		
37	ST.Strings-R	77	Metal Wind	117	REV Tin Wave		
38	ST.Strings-L	78	Feedbackwave	118	REV SN 1		
39	Mono Strings	79	Anklungs	119	REV SN 2		
40	Pizz	80	Wind Chimes	120	REV SN 3		

Numbers 130—135 and 137—142 use the waveforms of the commercially available "POP" (SR - JV - 80 - 01) expansion board. Also, numbers 145 - 152 were redesigned based on the waveforms of the commercially available "Grand Piano 1" (SO - PCM1 - 04) .

4. Preset Data

Internal

● Performance ● Patch

No	Name	No	Name	No	Name
UI01	Milky Way	UI11	Crystal Vox	UI51	Sea Shore
UI02	Black Hall	UI12	MIDI Ripper	UI52	Clean Strat
UI03	Afio Brass	UI13	Soundtrack	UI53	Mighty Pad
UI04	Movie Str	UI14	Poly Brass	UI54	Reso Brass
UI05	Analog Pad	UI15	Nice Piano	UI55	Jimmee Dee !
UI06	Analog Bs/Ld	UI16	Blow Lead	UI56	Sax Lead
UI07	Pipe	UI17	Ultima Bass	UI57	Untamed Bass
UI08	Mad Station	UI18	Amazon Moon	UI58	Morning
UI09	Bell Pad	UI21	Von Greece	UI61	JV Heaven
UI10	Analog Swell	UI22	BrightGuitar	UI62	Gtr Strings
UI11	Ripper Pad	UI23	Octava Strng	UI63	Wavox
UI12	Analog Brass	UI24	Brass Sect.	UI64	Afro Horn
UI13	Analog Orch	UI25	Blissful	UI65	West Coast
UI14	Melancholy	UI26	Square Lead	UI66	Doctor Bob
UI15	Hamming Gtr	UI27	Rubber Bs 3	UI67	5 - Strng Bass
UI16	Chaos	UI28	X/Y/Z	UI68	House Hunter
		UI31	Pulsynswell	UI71	Utakata
		UI32	Nylon Chorus	UI72	Classical Gt
		UI33	Orch Power	UI73	ChuChu Vox
		UI34	Mistress Brs	UI74	Brass Attack
		UI35	Stackoid	UI75	Mr.Mellow!
		UI36	Sawteeth	UI76	Belly Lead
		UI37	Slap !!!	UI77	Mondo Bass
		UI38	Kolor	UI78	Ice Hall
		UI41	Shakusphere	UI81	Ebb Tide
		UI42	Rhythmic	UI82	Gtr Fantasia
		UI43	Vocal Oohz	UI83	Reso Swell
		UI44	Hybrid Bones	UI84	Jam Brass
		UI45	Fantasia JV	UI85	JV Rhodes
		UI46	Doo Lead	UI86	Key Power !!
		UI47	Super JX Bs	UI87	Radio Bass
		UI48	Echo Riser	UI88	Arctic Winds

Preset A

● Performance ● Patch

No	Name	No	Name	No	Name
A01	Jazz Split	A11	A.Piano 1	A51	Tria Bells
A02	Softly.....	A12	A.Piano 2	A52	Wave Bells
A03	Bossa nova	A13	A.Piano 3	A53	Vibrobell
A04	Jazzygroove	A14	A.Piano 4	*A54	Chime Inn
A05	OLD Bar	A15	A.Piano 1Tx4	A55	E.Organ
A06	FUNKY	*A16	Rock Grand	A56	Jazz Organ 1
A07	Pop Fusion	A17	MIDled Grand	A57	Jazz Organ 2
A08	Fusion Set	A18	Pop Piano 1	*A58	Rock Organe
A09	Heavy	A21	Country Bar	*A61	Jazz Rattler
A10	Rokin Split	*A22	Stack Major	A62	Fine Organ
A11	Brass Rock	A23	Pop Piano 2	A63	Metal Organ
A12	Hard Wire	A24	RD Rhodes 1	A64	Organarimba
A13	Perc Harmnix	A25	Dig Rhodes 1	A65	Pipe Organ 1
A14	Classy Piano	A26	Dig Rhodes 2	A66	Pipe Organ 2
A15	Perc Strings	A27	Stiky Rhodes	A67	Church Organ
A16	Pop Orchestra	A28	Guitr Rhodes	*A68	Weddin Time
		A31	Pop Piano 3	A71	Nylon Gtr 1
		A32	FM.Piano	A72	Nylon Gtr 2
		*A33	Hi - Cut Ep	A73	Flanged NylN
		A34	MIDI EPiano	A74	SteelGuitar1
		A35	Clav 1	A75	SteelGuitar2
		*A36	Pulse Klav	A76	Velo Harmnix
		*A37	Wire Klav	A77	12 strings
		*A38	Flange Clav	*A78	Fake12string
		A41	Warm Vibe	A81	JC Strat
		A42	Vibe	A82	Clean Strat
		A43	Marimba	*A83	Strata
		A44	Lumber Jacow	A84	Stratus
		A45	Toy Box	A85	SwitchOnMute
		A46	Steel Drum	A86	Syn Strat
		*A47	Islands	A87	Syn Guitar
		*A48	AfricaMetals	A88	Overdrive

Patches indicated with a (*) are identical to those contained in the Roland Sound Library, "Contemporary COMPOSER by ANDREW SHLESINGER" (PN - JV80 - 05).

● To restore the JV - 90's internal memory to the factory default settings, first turn its power OFF. Then while holding down the NUMBER [8] button, turn power back ON again. You can then follow the messages that appear in the display and press [ENTER] then [WRITE]. To cancel the procedure, press [EXIT].

■ Preset B

● Performance ● Patch

No	Name	No	Name	No	Name
B01	GTR Players	B11	Woody Bass 1	B51	Brass Sect 1
B02	Synth Plus	B12	Woody Bass 2	B52	Brass Sect 2
B03	PianoEnsembl	B13	Hip Bass	B53	Brass Combo
B04	Church Choir	B14	Rock Bass	*B54	Fake Brass
B05	YMBA Choir	*B15	Pick Bass	*B55	Stab Brass
B06	THE MALLETS	B16	Thumpin Bass	B56	Brass Swell
B07	South Shore	B17	Fretless 1	*B57	Sax Section
B08	Guitar Club	B18	Fretless 2	B58	Horn Brass
B09	for CompuMix	B21	Analog Bs	B61	Trumpet 1
B10	Introduction	B22	House Bass	B62	Trumpet 2
B11	House Sounds	B23	Wonder Bass	B63	Trombone
B12	Cosmo Space	B24	Yowza Bass	B64	Harmon Mute1
B13	Acoustics	B25	Rubber Bs 1	B65	Harmon Mute2
B14	Finale!!	B26	Rubber Bs 2	B66	French Horn
B15	Perseverance	*B27	Asid Base	B67	Alto Sax 1
B16	New Listening	*B28	Doom Bass	B68	Alto Sax 2
		B31	St Strings	B71	Tenor Sax 1
		B32	Warm Strings	B72	Tenor Sax 2
		B33	Slow Strings	B73	Flute mod
		B34	SoarinString	B74	Piccolo
		B35	Marcato	B75	Air Lead
		*B36	Big Stringer	B76	Pan Pipe 1
		*B37	Score String	B77	Pan Pipe 2
		B38	TremoloStrng	B78	OverblownPan
		B41	JP Strings 1	B81	Ocarina
		B42	JP Strings 2	B82	Blow Square
		*B43	Synstringer	B83	Saku Pipe
		B44	String Synth	B84	Whistle 1
		B45	Pizzicato	B85	Whistle 2
		B46	Real Pizz	B86	Orch Stab 1
		*B47	Pick It	B87	Brite Stab
		B48	Harp	B88	Orch Stab 2

■ Preset C

● Performance ● Patch

No	Name	No	Name	No	Name
C01	Plk - A - Dee	C11	Saw Lead	C51	Poly MG
C02	ProgresSplit	C12	Syn SAX Lead	C52	Dist Line
C03	Space Travel	C13	Soft Lead 1	C53	Julia Pad
C04	Mondo Mono!!	C14	Soft Lead 2	C54	Analog Horn
C05	Stringers	C15	Harmo Lead	C55	Warm Brass
C06	Wash Comp	C16	Reso Lead	C56	Brass Pad
C07	Tinkle Wish	C17	Pulse Lead	C57	SoufulBrass
C08	World 7	C18	MMM Lead	C58	Ana Brass
C09	Dune	C21	Clav Lead	C61	Pizeza Hutt
C10	Braz Bande	C22	Square	*C62	JV Pizzottle
C11	Ethnotick	C23	OB Lead	*C63	Blo East
C12	Lite JV	*C24	High Lyle	*C64	Spook Metal
C13	Rim Cue	C25	VOX Lead 1	C65	Journey East
C14	Blo Hiss	C26	VOX Lead 2	*C66	Lite Delay
C15	Organic	C27	WhistlinAtom	C67	Velocifex
C16	So Lo	*C28	Russiastan	*C68	Rezitan
		C31	Touch Lead	*C71	Like Dee
		*C32	Digirez Lead	C72	Huff N Stuff
		C33	Another Lead	*C73	Bit World
		C34	A.T DCO Lead	*C74	Meta Compa
		*C35	Feed Lead	C75	Stratosphere
		C36	Real Pulse	C76	Les Rhythmo
		C37	Box Lead	C77	Heavens Door
		C38	Chu Ning !	C78	World Peace
		*C41	Lorise	*C81	Lovley World
		C42	Old man	*C82	Williamsong
		*C43	Duo Saw	C83	Son Of Atmos
		*C44	Wa - saw Phaze	C84	Autumn Breez
		*C45	Big Saw	*C85	On The Wire
		C46	Old Saw	*C86	Easternal
		C47	Pollyanna	*C87	Snake Up
		C48	Poly Portame	C88	Brassy VOX

Patches indicated with a (*) are identical to those contained in the Roland Sound Library, "Contemporary COMPOSER by ANDREW SHLESINGER" (PN - JV80 - 05).

■ Preset D

● Performance ● Patch

No	Name	No	Name	No	Name
D01	Space Vox	D11	Beauty Vox	D51	Ebb tide Pad
D02	Ethnic Bomb	D12	New Age Vox	*D52	Tangerine
D03	Fanta Brass	D13	Vento Voxx	D53	MillenniumJV
D04	Retro Str	D14	Pvox Oooze	D54	Fantasy Vox
D05	LittleWorld	D15	Vocal Oohz 2	*D55	Wisp Rush
D06	SFX	D16	JV Vox	*D56	Neurise
D07	Wistle Lead	D17	Arasian Morn	D57	Mouse Pad
D08	Oriental Brs	*D18	Love Trans	D58	Nature Pad
D09	Wire Keys	D21	Cosmo Vox 2	*D61	Slo Slagg
D10	Cosmic Pad	D22	Aurora	D62	Starsearch
D11	Maturation	D23	Press - Cooker	*D63	Atlantis
D12	Poly Synth	D24	YASURAGI	D64	Vortex CAfe
D13	Hyper Sonic	D25	Space Ahh	D65	4thDimension
D14	Stack Strngs	*D26	Pick - a - Doodl	*D66	Hy Entropy
D15	BellAtlantis	D27	DooWah Diddy	D67	Mellowtron
D16	Reverse Fx	D28	Pop Voice	D68	Power Saw
		D31	Analog Pad 1	D71	Big n Beefy
		D32	JP - 8 Pad	D72	Canal Zone
		D33	Analog Pad 2	*D73	Hie Cue
		D34	Analog Str	D74	Talking Pad
		D35	Analog Orch	D75	MMM Pad
		D36	SpaciosSweep	*D76	Low Wind
		*D37	Story Pad	*D77	SuspendTrump
		*D38	The Pad	*D78	Andromida
		D41	Wire Strings	*D81	The Scope
		*D42	Rimms	D82	Hammer Bell
		*D43	Slo Ep	*D83	Flue Taloo
		D44	Glasswaves 1	*D84	BeezieBreath
		D45	Glasswaves 2	D85	DistanceCall
		D46	Glass 1T	D86	Analog Seq
		D47	Glass Pad	D87	Reverse Mad
		D48	Hardy Winery	D88	RevCymBend

Patches indicated with a (*) are identical to those contained in the Roland Sound Library, "Contemporary COMPOSER by ANDREW SHLESINGER" (PN - JV80 - 05).

JV - 80 Compatible Preset a

● Performance ● Patch

No	Name	No	Name	No	Name
a01	Jazz Split	a11	A.Piano 1	a51	Nylon Gtr 1
a02	Softly.....	a12	A.Piano 2	a52	Flanged Nyln
a03	Bossa nova	a13	Mellow Piano	a53	Steel Guitar
a04	Jazzygroove	a14	Pop Piano 1	a54	PickedGuitar
a05	OLD Bar	a15	Pop Piano 2	a55	12 strings
a06	FUNKY	a16	Pop Piano 3	a56	Velo Harmnix
a07	Pop Fusion	a17	MIDled Grand	a57	Nylon+Steel
a08	Fusion Set	a18	Country Bar	a58	SwitchOnMute
a09	Heavy	a21	Glist El Pno	a61	JC Strat
a10	Rokin Split	a22	MIDI EPiano	a62	Stratus
a11	Brass Rock	a23	SA Rhodes	a63	Syn Strat
a12	Hard Wire	a24	Dig Rhodes 1	a64	Pop Strat
a13	Perc Harmnix	a25	Dig Rhodes 2	a65	Clean Strat
a14	Classy Piano	a26	Stiky Rhodes	a66	Funk Gtr
a15	Perc Strings	a27	Guitr Rhodes	a67	Syn Guitar
a16	PopOrchestra	a28	Nylon Rhodes	a68	Overdrive
		a31	Clav 1	a71	Fretless
		a32	Clav 2	a72	St Fretless
		a33	Marimba	a73	Woody Bass 1
		a34	Marimba SW	a74	Woody Bass 2
		a35	Warm Vibe	a75	Analog Bs 1
		a36	Vibe	a76	House Bass
		a37	Wave Bells	a77	Hip Bass
		a38	Vibrobell	a78	RockOut Bass
		a41	Pipe Organ 1	a81	Slap Bass
		a42	Pipe Organ 2	a82	Thumpin Bass
		a43	Pipe Organ 3	a83	Pick Bass
		a44	E.Organ 1	a84	Wonder Bass
		a45	E.Organ 2	a85	Yowza Bass
		a46	Jazz Organ 1	a86	Rubber Bs 1
		a47	Jazz Organ 2	a87	Rubber Bs 2
		a48	Metal Organ	a88	Stereoww Bs

JV - 80 Compatible Preset b

● Performance ● Patch

No	Name	No	Name	No	Name
b01	GTR Players	b11	Pizzicato	b51	Brass Combo
b02	Synth Plus	b12	Real Pizz	b52	Stab Brass
b03	PianoEnembl	b13	Harp	b53	Soft Brass
b04	Church Choir	b14	SoarinString	b54	Horn Brass
b05	YMBA Choir	b15	Warm Strings	b55	French Horn
b06	THE MALLETS	b16	Marcato	b56	AltoLead Sax
b07	South Shore	b17	St Strings	b57	Alto Sax
b08	Guitar Club	b18	Orch Strings	b58	Tenor Sax 1
b09	for CompuMlx	b21	Slow Strings	b61	Tenor Sax 2
b10	Introduction	b22	Velo Strings	b62	Sax Section
b11	House Sounds	b23	BrightStrngs	b63	Sax Tp Tb
b12	Cosmo Space	b24	TremoloStrng	b64	FlutePiccolo
b13	Acoustics	b25	Orch Stab 1	b65	Flute mod
b14	Finale!	b26	Brite Stab	b66	Ocarina
b15	Perseverance	b27	JP — 8 Strings	b67	OverblownPan
b16	NewListening	b28	String Synth	b68	Air Lead
		b31	Wire Strings	b71	Steel Drum
		b32	New Age Vox	b72	Log Drum
		b33	Arasian Morn	b73	Box Lead
		b34	Beauty Vox	b74	Soft Lead
		b35	Vento Voxx	b75	Whistle
		b36	Pvox Oooze	b76	Square Lead
		b37	GlassVoices	b77	Touch Lead
		b38	Space Ahh	b78	NightShade
		b41	Trumpet	b81	Pizza Hutt
		b42	Trombone	b82	EP+Exp Pad
		b43	Harmon Mute1	b83	JP — 8 Pad
		b44	Harmon Mute2	b84	Puff
		b45	TeaJay Brass	b85	SpaciosSweep
		b46	Brass Sect 1	b86	Big n Beefy
		b47	Brass Sect 2	b87	RevCymbBend
		b48	Brass Swell	b88	INITIAL DATA

- * To select the JV - 80 compatible Presets a/b, hold down [PCM CARD (A/B)] while you press [USER].
- * Within the Patches, Performances, and Rhythm Sets at the JV - 80 compatible preset memory (a/b), there are some which are identical to those stored in Preset Memory (A/B/C/D).
- * If you need "Analog Seq", select the preset patch D86 (P.129). The patch b88 is the initial data of the JV - 80.

Rhythm Set

		Internal	Preset A	Preset B
		Tone Name	Tone Name	Tone Name
C3	36	Bright Kick	Bright Kick	Bright Kick
	37	Cross Stick 1	Cross Stick 1	Cross Stick 1
	38	90's Snare	90's Snare	Piccolo SN
	39	808 Claps	808 Claps	808 Claps
	40	LA Snare	90's Snare	LA Snare
	41	Power Tom Lo	Power Tom Lo	Power Tom Lo
	42	Closed HAT 1	Closed HAT 1	Closed HAT 1
	43	Power Tom Lo	Power Tom Lo	Power Tom Lo
	44	Closed HAT 2	Closed HAT 2	Closed HAT 2
	45	Power Tom Hi	Power Tom Hi	Power Tom Lo
	46	Open HAT 1	Open HAT 1	Open HAT 1
	47	Power Tom Hi	Power Tom Hi	Power Tom Lo
C3	48	Power Tom Hi	Power Tom Hi	Power Tom Hi
	49	Crash 1	Crash 1	Crash 1
	50	Power Tom Hi	Power Tom Hi	Power Tom Hi
	51	Ride 1	Ride 1	Ride 1
	52	Ride Bell 1	Tin Wave	Crash 1
	53	REV SN 1	Ride Bell 1	Ride Bell 1
	54	Tambourine	Tambourine	Crash 1
	55	REV SN 2	Spectrum 1	Crash 1
	56	Cowbell 1	Cowbell 1	Cowbell 1
	57	REV SN 3	Crash 1	Crash 1
	58	Cowbell 1	Crash 1	Cowbell 1
	59	REV SN 4	Piccolo SN	Crash 1
C4	60	CGA Mute Hi	CGA Mute Hi	CGA Mute Hi
	61	CGA Mute Lo	CGA Mute Lo	Conga Hi
	62	CGA Slap	CGA Slap	CGA Slap
	63	Conga Hi	Conga Hi	Conga Lo
	64	Conga Lo	Conga Lo	CGA Mute Lo
	65	Timbale	Timbale	Timbale
	66	Timbale	Timbale	Timbale
	67	Agogo	Power Tom Lo	Timbale
	68	Agogo	LA Snare	Timbale
	69	Cabasa Up	Cabasa Up	Agogo
	70	Maracas	Maracas	Agogo
	71	Cabasa Down	Cabasa Down	Cabasa Up
C5	72	Maracas Cut	Cabasa Cut	Cabasa Down
	73	808 Kick	Whack Snare	Maracas
	74	808 SNR 1	Verb Kick	Cabasa Cut
	75	DIGI Bell 1	Rim Shot	Tambourine
	76	808 SNR 1	Round Kick	Log Drum
	77	808 Kick	808 Kick	DIGI Bell 1
	78	Spectrum 1	Cabasa Down	DIGI Chime
	79	808 Kick	REV Steel DR	Steel Drums
	80	Spectrum 1	REV Tin Wave	Anklungs
	81	808 Kick	REV SN 1	Wind Chimes
	82	Spectrum 1	REV SN 2	Rattles
	83	808 Kick	REV SN 3	Ronund Kick
C6	84	808 Kick	Wind Chimes	808 Kick
	85	Feedbackwave	REV Kick	808 Kick
	86	808 Kick	Anklungs	808 SNR 1
	87	Feedbackwave	Rattles	REV TAMB
		Pop Voice	REV Cow Bell	90's Snare
	89	Pop Voice	REV TAMB	Closed HAT 1
	90	Wind Agogo	REV Conga	Tin Wave
	91	Pop Voice	REV Maracas	Spectrum 1
	92	Wind Agogo	REV Crash 1	REV Steel DR
	93	Open HAT 1	Steel Drums	REV Tin Wave
	94	Anklungs	Wind Agogo	REV SN 1
		Open HAT 1	Wind Agogo	REV Crash 1
C7	96	Open HAT 1	808 SNR 1	REV Cow Bell

* On the JV-90, 808 SNR (switched off) is assigned to Key Numbers 28-35 and 97-103. You can use them by editing data. Edited data can be written in UI and UC. (P.90)

		Preset C		Preset D	
		Tone Name		Tone Name	
C2	36		Bright Kick		Verb Kick
		37	Cross Stick 1		Cross Stick 1
C3	38		90's Snare		90's Snare
		39	808 Claps		808 Claps
C4	40		90's Snare		Piccolo SN
	41		Power Tom Lo		Tom Lo
C5		42	Closed HAT 1		Closed HAT 1
	43		Power Tom Lo		Power Tom Lo
C6		44	Closed HAT 2		Closed HAT 2
	45		Power Tom Hi		Tom Hi
C7		46	Open HAT 1		Open HAT 1
	47		Power Tom Hi		Power Tom Lo
C8	48		Power Tom Hi		Tom Hi
		49	Crash 1		Crash 1
C9	50		Power Tom Hi		Power Tom Hi
		51	Ride 1		Ride 1
C10	52		Ride Bell 1		Ride 2
		53	Ride Bell 1		Ride Bell 1
C11		54	Tambourine		Tambourine
	55		Spectrum 1		REV SN 2
C12		56	Cowbell 1		Cowbell 1
	57		Crash 1		Crash 1
C13		58	Crash 1		LA Snare
	59		Piccolo SN		REV SN 4
C14	60		CGA Mute Hi		CGA Mute Hi
		61	CGA Mute Lo		CGA Mute Lo
C15	62		CGA Slap		CGA Slap
		63	Conga Hi		Conga Hi
C16	64		Conga Lo		Conga Lo
	65		Timbale		Timbale
C17		66	Timbale		Timbale
	67		Cross Stick 1		Agogo
C18		68	LA Snare		Agogo
	69		Cabasa Up		Cabasa Up
C19		70	Maracas		Maracas
	71		Cabasa Down		Cabasa Down
C20	72		Cabasa Cut		Cabasa Cut
		73	808 Kick		Rattles
C21	74		808 Kick		Wind Chimes
		75	808 SNR 1		DIGI Bell 1
C22	76		808 SNR 1		REV SN 3
		77	Wind Chimes		808 Kick
C23		78	Cabasa Down		Spectrum 1
	79		REV SN 1		808 SNR 1
C24		80	REV SN 3		Spectrum 1
	81		REV Tom		808 Kick
C25		82	REV SN 2		Spectrum 1
	83		REV Cow Bell		Bright Kick
C26	84		Wind Chimes		808 Kick
		85	White Noise		Round Kick
C27	86		Anklungs		Whack Snare
		87	Rattles		Rim Shot
C28	88		Rattles		LA Snare
		89	REV Crash 1		Brush Slap
C29		90	Cowbell 1		Pedal HAT 1
	91		REV Maracas		Brush Swish
C30		92	REV Crash 1		Open Triangl
	93		90's Snare		Brush Roll
C31		94	Wind Agogo		Open Triangl
	95		Closed HAT 1		Conga Lo
C32	96		808 SNR 1		Open HAT 1

* On the JV-90, 808 SNR (switched off) is assigned to Key Numbers 28-35 and 97-103. You can use them by editing data. Edited data can be written in UI and UC. (P.90)

JV - 80 Compatible Rhythm Set

		Preset a	Preset b
		Tone Name	Tone Name
C2	36	Bright Kick	Bright Kick
	37	Cross Stick 1	Cross Stick 1
	38	90's Snare	Piccolo SN
	39	808 Claps	808 Claps
C3	40	90's Snare	LA Snare
	41	Power Tom Lo	Power Tom Lo
	42	Closed HAT 1	Closed HAT 1
	43	Power Tom Lo	Power Tom Lo
	44	Closed HAT 2	Closed HAT 2
	45	Power Tom Hi	Power Tom Lo
	46	Open HAT 1	Open HAT 1
	47	Power Tom Hi	Power Tom Lo
	48	Power Tom Hi	Power Tom Hi
	49	Crash 1	Crash 1
	50	Power Tom Hi	Power Tom Hi
	51	Ride 1	Ride 1
C4	52	Tin Wave	Crash 1
	53	Ride Bell 1	Ride Bell 1
	54	Tambourine	Crash 1
	55	Spectrum 1	Crash 1
	56	Cowbell 1	Cowbell 1
	57	Crash 1	Crash 1
	58	Crash 1	Cowbell 1
	59	Piccolo SN	Crash 1
	60	CGA Mute Hi	CGA Mute Hi
	61	CGA Mute Lo	Conga Hi
	62	CGA Slap	CGA Slap
	63	Conga Hi	Conga Lo
C5	64	Conga Lo	CGA Mute Lo
	65	Timbale	Timbale
	66	Timbale	Timbale
	67	Power Tom Lo	Timbale
	68	LA Snare	Timbale
	69	Cabasa Up	Agogo
	70	Maracas	Agogo
	71	Cabasa Down	Cabasa Up
	72	Maracas Cut	Cabasa Down
	73	Whack Snare	Maracas
	74	Verb Kick	Maracas Cut
	75	Rim Shot	Tambourine
C6	76	Round Kick	Log Drum
	77	808 Kick	DIGI Bell 1
	78	Cabasa Down	DIGI Chime
	79	REV Steel DR	Steel Drums
	80	REV Tin Wave	Anklungs
	81	REV SN 1	Wind Chimes
	82	REV SN 2	Rattles
	83	REV SN 3	Ronund Kick
	84	Wind Chimes	808 Kick
	85	REV Kick	808 Kick
	86	Anklungs	808 SNR 1
	87	Rattles	REV TAMB
C7	88	REV Cow Bell	90's Snare
	89	REV TAMB	Closed HAT 1
	90	REV Conga	Tin Wave
	91	REV Maracas	Spectrum 1
	92	REV Crash	REV Steel DR
	93	Steel Drum	REV Tin Wave
	94	Wind Agogo	REV SN 1
	95	Wind Agogo	REV Crash 1
	96	808 SNR 1	REV Cow Bell

- * To select the JV - 80 compatible Presets a/b, hold down [PCM CARD (A/B)] while you press [USER].
- * Within the Patches, Performances, and Rhythm Sets at the JV - 80 compatible preset memory (a/b), there are some which are identical to those stored in Preset Memory (A/B/C/D).
- * On the JV-90, 808 SNR (switched off) is assigned to Key Numbers 28-35 and 97-103. You can use them by editing data. Edited data can be written in UI and UC. (P.90)

5. MIDI Reference

■ Roland Exclusive Messages

1. Data Format for Exclusive Messages

Roland's MIDI implementation uses the following data format for all exclusive messages (type IV):

Byte	Description
F0H	Exclusive status
41H	Manufacturer ID (Roland)
DEV	Device ID
MDL	Model ID
CMD	Command ID
[BODY]	Main data
F7H	End of exclusive

#MIDI status: F0H, F7H

An exclusive message must be flanked by a pair of status codes, starting with a Manufacturer-ID immediately after F0H (MIDI version 1.0).

#Manufacturer-ID : 41H

The Manufacturer-ID identifies the manufacturer of a MIDI instrument that triggers an exclusive message. Value 41H represents Roland's Manufacturer-ID.

#Device-ID: DEV

The Device-ID contains a unique value that identifies the individual device in the multiple implementation of MIDI instruments. It is usually set to 00H — 0FH, a value smaller by one than that of a basic channel, but value 00H — 1FH may be used for a device with multiple basic channels.

#Model-ID : MDL

The Model-ID contains a value that uniquely identifies one model from another. Different models, however, may share an identical Model-ID if they handle similar data.

The Model-ID format may contain 00H in one or more places to provide an extended data field. The following are examples of valid Model-IDs, each representing a unique model:

01H
02H
03H
00H, 01H
00H, 02H
00H, 00H, 01H

#Command-ID : CMD

The Command-ID indicates the function of an exclusive message. The Command-ID format may contain 00H in one or more places to provide an extended data field. The following are examples of valid Command-IDs, each representing a unique function:

01H
02H
03H
00H, 01H
00H, 02H
00H, 00H, 01H

#Main data : BODY

This field contains a message to be exchanged across an interface. The exact data size and contents will vary with the Model-ID and Command-ID.

2. Address-mapped Data Transfer

Address mapping is a technique for transferring messages conforming to the data format given in Section 1. It assigns a series of memory-resident records—waveform and tone data, switch status, and parameters, for example—to specific locations in a machine-dependent address space, thereby allowing access to data residing at the address a message specifies.

Address-mapped data transfer is therefore independent of models and data categories. This technique allows use of two different transfer procedures: one-way transfer and handshake transfer.

One-way transfer procedure (See Section 3 for details.)

This procedure is suited for the transfer of a small amount of data. It sends out an exclusive message completely independent of a receiving device status.

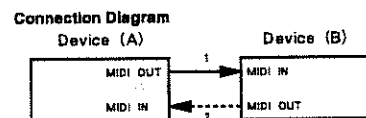

Connection at point 2 is essential for "Request data" procedures. (See Section 3.)

#Handshake-transfer procedure (This device does not cover this procedure)

This procedure initiates a predetermined transfer sequence (handshaking) across the interface before data transfer takes place. Handshaking ensures that reliability and transfer speed are high enough to handle a large amount of data.

Connection Diagram

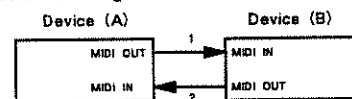

Connection at points 1 and 2 is essential.

Notes on the above two procedures

- * There are separate Command-IDs for different transfer procedures.
- * Devices A and B cannot exchange data unless they use the same transfer procedure, share identical Device-ID and Model ID, and are ready for communication.

3. One-way Transfer Procedure

This procedure sends out data all the way until it stops and is used when the messages are so short that answerbacks need not be checked.

For long messages, however, the receiving device must acquire each message in time with the transfer sequence, which inserts intervals of at least 20 milliseconds in between.

Types of Messages

Message	Command ID
Request data 1	RQ1 (11H)
Data set 1	DT1 (12H)

#Request data #1 : RQ1 (11H)

This message is sent out when there is a need to acquire data from a device at the other end of the interface. It contains data for the address and size that specify designation and length, respectively, of data required.

On receiving an RQ1 message, the remote device checks its memory for the data address and size that satisfy the request.

If it finds them and is ready for communication, the device will transmit a "Data set 1 (DT1)" message, which contains the requested data. Otherwise, the device will send out nothing.

Byte	Description
F0H	Exclusive status
41H	Manufacturer ID (Roland)
DEV	Device ID
MDL	Model ID
11H	Command ID
aaH	Address MSB
⋮	⋮
	LSB
ssH	Size MSB
⋮	⋮
	LSB
sum	Check sum
F7H	End of exclusive

- * The size of the requested data does not indicate the number of bytes that will make up a DT1 message, but represents the address fields where the requested data resides.
- * Some models are subject to limitations in data format used for a single transaction. Requested data, for example, may have a limit in length or must be divided into predetermined address fields before it is exchanged across the interface.
- * The same number of bytes comprises address and size data, which, however, vary with the Model-ID.
- * The error checking process uses a checksum that provides a bit pattern where the least significant 7 bits are zero when values for an address, size, and that checksum are summed.

#Data set 1 : DT1 (12H)

This message corresponds to the actual data transfer process. Because every byte in the data is assigned a unique address, a DT1 message can convey the starting address of one or more data as well as a series of data formatted in an address-dependent order.

The MIDI standards inhibit non-real time messages from interrupting an exclusive one. This fact is inconvenient for the devices that support a "soft-through" mechanism. To maintain compatibility with such devices, Roland has limited the DT1 to 256 bytes so that an excessively long message is sent out in separate segments.

Byte	Description
F0H	Exclusive
41H	Manufacturer ID (Roland)
DEV	Device ID
MDL	Model ID
12H	Command ID
aaH	Address MSB
⋮	⋮
	LSB
ddH	Data
⋮	⋮
sum	Check sum
F7H	End of exclusive

- * A DT1 message is capable of providing only the valid data among those specified by an RQ1 message.
- * Some models are subject to limitations in data format used for a single transaction. Requested data, for example, may have a limit in length or must be divided into predetermined address fields before it is exchanged across the interface.
- * The number of bytes comprising address data varies from one Model-ID to another.
- * The error checking process uses a checksum that provides a bit pattern where the least significant 7 bits are zero when values for an address, size, and that checksum are summed.

#Example of Message Transactions

- **Device A sending data to Device B**
Transfer of a DT1 message is all that takes place.

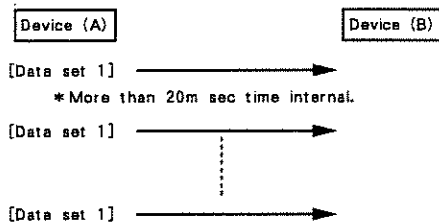

- **Device B requesting data from Device A**
Device B sends an RQ1 message to Device A. Checking the message, Device A sends a DT1 message back to Device B.

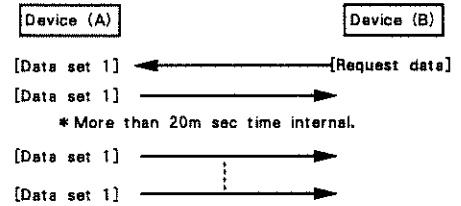

1. RECEIVE DATA

■ Channel Voice Message

● Note off

Status	Second	Third
8nH	kkH	vvH
9nH	kkH	00H

n = MIDI channel number : 0H - FH (ch.1 - ch.16)
 kk = Note number : 00H - 7FH (0 - 127)
 vv = Velocity : 00H - 7FH (0 - 127)

* In the performance mode, ignored when the MIDI receive switch is OFF at each part.

* In the rhythm part (part8), ignored when "ENV mode" is "NO-SUSTAIN" at each rhythm tone.

● Note on

Status	Second	Third
9nH	kkH	vvH

n = MIDI channel number : 0H - FH (ch.1 - ch.16)
 kk = Note number : 00H - 7FH (0 - 127)
 vv = Velocity : 01H - 7FH (1 - 127)

* In the performance mode, ignored when the MIDI receive switch is OFF at each part.

● Control change

○ Bank select MSB/LSB

Status	Second	Third
BnH	00H	mmH
BnH	20H	llH

n = MIDI channel number : 0H - FH (ch.1 - ch.16)
 mm = MSB of bank number : 50H - 54H (80 - 84)
 ll = LSB of bank number : 00H - 7FH (0 - 127)

- * The bank select is suspended until receiving a program change.
- * Ignored when "Program bank sel" of the system common is OFF.
- * In the patch mode, selected a bank of the patch memory. In the performance mode, selected a bank of the performance part memory. And specified the control channel, selected a bank of the performance itself.
- * The bank number specified as follow.

Bank Select | Program Change | Media (Patch Number)

MSB LSB		
80 0	1 - 64	Internal (#1 - #64)
80 0	65 - 128	Data Card (#1 - #64)
81 0	1 - 64	JV-80 Preset A (#1 - #64)
81 0	65 - 128	JV-80 Preset B (#1 - #64)
81 1	1 - 64	Preset A (#1 - #64)
81 1	65 - 128	Preset B (#1 - #64)
81 2	1 - 64	Preset C (#1 - #64)
81 2	65 - 128	Preset D (#1 - #64)
82 0	1 - 64	Data Card (#1 - #64)
83 0	1 - 128	PCM Card (#1 - #128)
84 0	1 - 128	Expansion Board (#1 - #128)
84 1	1 - 128	Expansion Board (#129 - #256)

○ Modulation

Status	Second	Third
BnH	01H	vvH

n = MIDI channel number : 0H - FH (ch.1 - ch.16)
 vv = Modulation depth : 00H - 7FH (0 - 127)

- * The effect of the modulation depends on the value of "Mod1-4" of the patch tone.
- * Ignored when "Receive Modulation" of the system common is OFF.

○ Portamento time

Status	Second	Third
BnH	05H	vvH

n = MIDI channel number : 0H - FH (ch.1 - ch.16)
 vv = Portamento time : 00H - 7FH (0 - 127)

- * You can adjust the portamento time of the patch common.
- * Ignored when "Receive Control change" of the system common is OFF.

○ Volume

Status	Second	Third
BnH	07H	vvH

n = MIDI channel number : 0H - FH (ch.1 - ch.16)
 vv = Volume : 00H - 7FH (0 - 127)

- * You can adjust the volume of specified channel.
- * Ignored when "Receive Volume" of the system common is OFF.
- * In the performance mode, ignored when the volume receive switch is OFF at each part.
- * Ignored when "Volume switch" of the patch tone is OFF.

○ Pan

Status	Second	Third
BnH	0AH	vvH

n = MIDI channel number : 0H - FH (ch.1 - ch.16)
 vv = Pan : 00H - 7FH (0 - 127)

- * "0" represents left end, "64" represents the center, and "127" represents right end.
- * Ignored when "Receive Control change" of the system common is OFF.

○ Expression

Status	Second	Third
BnH	0BH	vvH

n = MIDI channel number : 0H - FH (ch.1 - ch.16)
 vv = Expression : 00H - 7FH (0 - 127)

- * The effect of the expression depends on the value of "Exp1-4" of the patch tone.
- * Ignored when "Receive Control change" of the system common is OFF.

○ Hold1

Status	Second	Third
BnH	40H	vvH

n = MIDI channel number : 0H - FH (ch.1 - ch.16)
 vv = Control value : 00H - 7FH (0 - 127) 0 - 63 = OFF 64 - 127 = ON

- * Notes played can be sustained for as long as the time that elapses between turning hold on and turning hold off.
- * Ignored when "Receive Control change" of the system common is OFF.
- * In the performance mode, ignored when the hold1 receive switch is OFF at each part.
- * In the rhythm part (part8), ignored when "ENV mode" is "NO-SUSTAIN" at each rhythm tone.
- * Ignored when "Hold-1 switch" of patch tone is OFF.

○ Portamento

Status	Second	Third
BnH	41H	vvH

n = MIDI channel number : 0H - FH (ch.1 - ch.16)
 vv = Control value : 00H - 7FH (0 - 127) 0 - 63 = OFF 64 - 127 = ON

- * Switched over "Portamento sw" of patch common.
- * Ignore when "Receive Control change" of the system common is OFF.

○ Effect1 depth(Reverb send level)

Status	Second	Third
BnH	5BH	vvH

n = MIDI channel number : 0H - FH (ch.1 - ch.16)
 vv = Control value : 00H - 7FH (0 - 127) 0 - 63 = OFF 64 - 127 = ON

- * In the patch mode, switched over the reverb switch of the system common.
- * In the performance mode, switched over the reverb switch of the performance part.
- And specified the control channel, switched over the reverb switch of the system common.
- * Ignore when "Receive Control change" of the system common is OFF.

○ Effect3 depth(Chorus send level)

Status	Second	Third
BnH	5DH	vvH

n = MIDI channel number : 0H - FH (0 - 15) (ch.1 - ch.16)
 vv = Control value : 00H - 7FH (0 - 127) 0 - 63 = OFF 64 - 127 = ON

- * In the patch mode, switched over the chorus switch of the system common.
- * In the performance mode, switched over the chorus switch of the performance part.
- And specified the control channel, switched over the chorus switch of the system common.
- * Ignored when "Receive Control change" of the system common is OFF.

○ RPN MSB/LSB

Status	Second	Third
BnH	65H	mmH
BnH	64H	llH

n = MIDI channel number : 0H - FH (ch.1 - ch.16)
 mm = MSB of the specified parameter by RPN
 ll = LSB of the specified parameter by RPN

○ Data entry MSB/LSB

Status	Second	Third
BnH	06H	mmH
BnH	26H	llH

n = MIDI channel number : 0H - FH (ch.1 - ch.16)
 mm = MSB of the value of the parameter specified with RPN
 ll = LSB of the value of the parameter specified with RPN

- * Ignored when "Receive Control change" of the system common is OFF.

** RPN **

RPN (registered parameter number) is a parameter number of tone color or musical expression defined in MIDI specification.

With the JV-90 as the receiver, RPN # 0 (pitch bend sensitivity), RPN # 1 (fine tuning) and RPN # 2 (coarse tuning) are effective. When sending an RPN to the JV-90, first specify the MSB and LSB of the RPN to be used to control a parameter and then set the value in the data entry field.

RPN Data entry Description

MSB LSB MSB LSB

00H 00H mmH ---

Pitch bend sensitivity
 mm : 00H - 00H (0 - 12 semitone)
 ll : Ignored
 (Up to 1 octave)

- * You can adjust "Bend range up" and "Bend range down" at same time.
- * In the rhythm part(part8), this message is not recognized.

00H 01H mmH llH

Fine tuning
 mm, ll : 20H, 00H - 40H, 00H - 60H, 00H
 (-50 - 0 - +50 cent)

- * In the patch mode, adjusted the master tune.
- * In the performance mode, adjusted fine tune at each part.
- * In the performance mode, specified control channel, changed the master tune.

00H 02H mmH ---

Coarse tuning
 mm : 10H - 40H - 70H
 (-48 - 0 - +48 semitone)

- ll : Ignored
- * In the patch mode, this message is not recognized.
- * In the performance mode, adjusted coarse tune at each part.

7FH 7FH --- ---

RPN reset

- mm, ll : Ignored
- * Return to no specified parameter of RPN. Current setting value is no change.

● Program change

Status	Second
CnH	ppH

n = MIDI channel number : 0H - FH (ch.1 - ch.16)
 pp = Program number : 00H - 7FH (prog.1 - prog.128)

- * Ignored when "Receive Program change" of the system common is OFF.
- * When the JV-90 receives a program change on a part receive channel while in the performance mode, it changes the patches of that part: the new patch value being the program number plus 1. If the JV-90 receives the program change on the control channel, it changes the performance.

● Channel pressure

Status	Second
DnH	vvH

n = MIDI channel number : 0H - FH (ch.1 - ch.16)
 vv = Pressure value : 00H - 7FH (0 - 127)

- * The effect of the Channel pressure depends on the value of "After1-4" of the patch tone.
- * Ignored when "Receive Aftertouch" of the system common is OFF.

● Pitch bend change

Status	Second	Third
EnH	llH	mmH

n = MIDI channel number : 0H - FH (ch.1 - ch.16)
 mm, ll = Pitch bend change : 00H, 00H - 7FH, 7FH (-8192 - 0 - +8191)

- * Ignored when "Receive Pitch bend" of the system common is OFF.

■ Channel Mode Message

● Reset All Controllers

Status	Second	Third
BnH	79H	00H

n = MIDI channel number : 0H - FH (ch.1 - ch.16)

* Received this message, The controllers is set the following.

Controller	Value
Modulation	0(off)
Volume	127(maximum)
Pan	64(center)
Expression	0(off)
Hold1	0(off)
Channel pressure	0(off)
Pitch bend change	±0(center)
RPN	No specified parameter, value is no change.

● Local control

Status	Second	Third
BnH	7BH	vvH

n = MIDI channel number : 0H - FH (ch.1 - ch.16)

vv = Value : 00H, 7FH (0, 127) 0 = OFF 127 = ON

● All notes off

Status	Second	Third
BnH	7BH	00H

n = MIDI channel number : 0H - FH (ch.1 - ch.16)

* When this message is recognized, all the notes which have been turned on by MIDI note on message are turned off.

● OMNI OFF

Status	Second	Third
BnH	7CH	00H

n = MIDI channel number : 0H - FH (ch.1 - ch.16)

* Recognized as all notes off.

● OMNI ON

Status	Second	Third
BnH	7DH	00H

n = MIDI channel number : 0H - FH (ch.1 - ch.16)

* Recognized as all notes off. (JV - 90 doesn't recognize OMNI ON.)

● MONO

Status	Second	Third
BnH	7EH	mmH

n = MIDI channel number : 0H - FH (ch.1 - ch.16)

mm = Number of mono : 0H - FH (0 - 16)

* Switched over "Assign mode" of patch common.

* Recognized as all notes off, and set MODE4 (M=1) at each part.

● POLY

Status	Second	Third
BnH	7FH	00H

n = MIDI channel number : 0H - FH (ch.1 - ch.16)

* Switched over "Assign mode" of patch common.

* Recognized all notes off, and set MODE3 at each part.

■ System Realtime message

● Active sensing

Status
FEH

* When JV - 90 receive "active sensing", it measures time intervals between incoming messages. If the subsequent message will not come within about 300 ms after previous one, JV - 90 turn off all MIDI-on notes as if it receive "reset all controllers", and stop measuring message interval.

■ System Exclusive Message

Status	Data
FOH	iiH ddHeeH
F7H	

FOH : System exclusive
 ii = Manufacturer ID : 41H (65)
 ddee = Data : 00H - 7FH (0 - 127)
 F7H : EOX (End of exclusive)

Ignored when "Receive Exclusive" of the system common is OFF.
 Refer to section 3, 4.

2. TRANSMIT DATA

■ Channel Voice Data

● Note off

Status	Second	Third
8nH	kkH	vvH

n = MIDI channel number : 0H - FH (ch.1 - ch.16)

kk = Note number : 00H - 7FH (0 - 127)

vv = Velocity : 00H - 7FH (0 - 127)

* In the performance mode, not transmit when the MIDI transmit switch is OFF at each part.

● Note on

Status	Second	Third
9nH	kkH	vvH

n = MIDI channel number : 0H - FH (ch.1 - ch.16)

kk = Note number : 00H - 7FH (0 - 127)

vv = Velocity : 01H - 7FH (1 - 127)

* In the performance mode, not transmit when the MIDI transmit switch is OFF at each part.

● Control change

* The function of the Modulation lever is determined by control number 1 (modulation).

* The function of the Hold pedal is determined by control number 64 (hold1).

* Control numbers 0 - 95 can be assigned to Pedal1, Pedal2 and C1.

Status	Second	Third
BnH	ccH	vvH

n = MIDI channel number : 0H - FH (ch.1 - ch.16)

cc = Control number : 0H - 3FH, 46H - 5FH (0 - 63, 70 - 95)

vv = Control value : 00H - 7FH (0 - 127)

Status	Second	Third
BnH	ccH	vvH

n = MIDI channel number : 0H - FH (ch.1 - ch.16)

cc = Control number : 40H - 45H (64 - 69)

vv = Control value : 00H, 7FH (0, 127)

* Control change messages will not be transmitted when the following parameter are set :

Control number	TRANSMIT MIDI
0, 32(Bank Select)	Bank-OFF
1, 33(Modulation)	Mod-OFF
7, 39(Volume)	Vol-OFF
2 - 6, 8 - 31, 34 - 38, 40 - 95	C.C-OFF

● Program change

Status	Second
CnH	ppH

n = MIDI channel number : 0H - FH (ch.1 - ch.16)
 pp = Program number : 00H - 7FH (prog.1 - prog.128)

* Not transmit when "Transmit Program change" of the system common is OFF.

● Channel pressure

Status	Second
DnH	vvH

n = MIDI channel number : 0H - FH (ch.1 - ch.16)
 vv = Value : 00H - 7FH (0 - 127)

* Not transmit when "Transmit Aftertouch" of the system common is OFF.

● Pitch bend change

Status	Second	Third
EnH	lH	mmH

n = MIDI channel number : 0H - FH (ch.1 - ch.16)
 mm,l = Value : 00H,00H - 7FH,7FH (-8192 - +8191)

* Not transmit when "Transmit Pitch bend" of the system common is OFF.

■ System Real Time Message

● Active sensing

Status
FEH

* This message transmit at about 300 milli-seconds interval.

■ System Exclusive Message

Status	Data
FOH	iiH ddHeeH
F7H	

FOH : System exclusive
 ii = Manufacturer ID : 41H (65)
 ddee = Data : 00H - 7FH (0 - 127)
 F7H : EOX (End of exclusive)

Refer to section 3, 4.

3. Exclusive communications

The JV-90 can send and receive patch parameter, etc using the system exclusive message.

The model ID code of the JV-90 is 46H. The device ID code is to be determined by the unit number setting of MIDI function.

The JV-90 ignores GS exclusive messages other than scale tune parameter. The model ID of the GS is 42H.

■ One way communication

● Request data 1 RQ1 (11H)

Byte	Description
FOH	Exclusive status
41H	Manufacturer ID (Roland)
Dev	Device ID (Dev = UNIT# - 1)
46H	Model ID (JV-90)
11H	Command ID (RQ1)
aaH	Address MSB
bbH	Address
ccH	Address
ddH	Address LSB
ssH	Size MSB
ttH	Size
uuH	Size
vvH	Size LSB
sum	Check sum
F7H	EOX (End of exclusive)

* Receive only: the JV-90 does not send this message.

● Data set 1 DT1 (12H)

1. JV-90 (MODEL ID = 46H)

Byte	Description
FOH	Exclusive status
41H	Manufacturer ID (Roland)
Dev	Device ID (Dev = UNIT# - 1)
46H	Model ID (JV-90)
12H	Command ID (DT1)
aaH	Address MSB
bbH	Address
ccH	Address
ddH	Address LSB
eeH	Data
:	:
ffH	Data
sum	Check sum
F7H	EOX (End of exclusive)

2. GS (MODEL ID = 42H)

Byte	Description
FOH	Exclusive status
41H	Manufacturer ID (Roland)
Dev	Device ID (Dev = UNIT# - 1)
42H	Model ID (GS)
12H	Command ID (DT1)
aaH	Address MSB
bbH	Address
ccH	Address LSB
eeH	Data
:	:
ffH	Data
sum	Check sum
F7H	EOX (End of Exclusive)

Note: When the device ID is 7FH, JV-90 can receive the GS exclusive message even if the unit number is anything.

4. Parameter address map

Address and size are configured in 7 bits, and expressed in hexadecimal.

Address	MSB			LSB	
Binary	0aaa	aaaa	0bbb	bbbb	0ccc
7-bit hex	AA		BB		CC
Binary	0ddd	dddd	0eee	eeee	0fff
7-bit hex	DD		EE		FF

Size	MSB			LSB	
Binary	0sss	ssss	0ttt	tttt	0uuu
7-bit hex	SS		TT		UU
Binary	0vvv	vvvv	0www	wwww	0xxx
7-bit hex	VV		WW		XX

Parameter base address

All data sent in exclusive message are given particular addresses to identify parameters. These addresses are the sum of the base address and offset address. Some parameters are defined using multiple offsets. The address included in the message of a data set or a data request must be within the value shown in the table below.

Note: A pair of two addresses preceded by the symbol # represents a divided - by - two data. e.g. the data ABH (hex) is divided into 0AH and 0BH and sent in that order.

Note: Parameters associated with address following the symbol % are for JV - 880 and invalid with the JV - 90.

Example of exclusive data

To set the reverb type of the temporary performance common to "DELAY", send the following data to the JV - 90.

FOH	41H	10H	46H	12H	00H	00H	10H	00H	06H	5DH	7FH
1	2	3	4	5	6	7	8	9			

- Exclusive status
- Manufacturer ID: Roland=41H.
- Device ID: the unit number of the system common parameter minus 1. In this example, the unit number is 17: 17 - 1=16 which is expressed as 10H in hexadecimal notation.
- Model ID of the JV - 90 is 46H.
- Command ID: data set 1=12H.
- Addresses: by referring to Table 1, the start address of the temporary performance=00H 00H 10H 00H; from Table 1-2, offset address of performance common=00H 00H; from Table 1-2-1, offset address of reverb type=0DH. These addresses are added together:

```

00H 00H 10H 00H
  00H 00H
+) 0DH
-----
00H 00H 10H 0DH = target address

```

- The number of "DELAY" is 6: 06H in hexadecimal.
- Check sum
The error checking process uses a checksum and provides a bit pattern where the last significant 7 bits are zero, when values for an address, data (or size) and the checksum are summed.

<Example>

80H - 1(00H + 00H + 10H + 0DH + 06H) & 7FH | = 5DH

Address	Data

- End of exclusive

1 JV-90

< MODEL ID = 46H >

Start address	Description	
00 00 00 00	System Common	*1-1
00 00 10 00	Temporary Performance	*1-2
00 00 20 00	Performance Mode Temporary Patch (Part 1)	*1-3
00 01 20 00	Performance Mode Temporary Patch (Part 2)	
:	:	
00 06 20 00	Performance Mode Temporary Patch (Part 7)	
00 07 40 00	Temporary Rhythm Setup	*1-4
00 08 20 00	Patch Mode Temporary Patch	*1-3
00 20 00 00	Temporary Rhythm Setup 2	*1-4
01 00 10 00	Internal Performance IO1	*1-2
01 01 10 00	Internal Performance IO2	
:	:	
01 0F 10 00	Internal Performance I16	
01 20 00 00	Internal Rhythm Setup 2	*1-5
01 40 20 00	Internal Patch I11	*1-3
01 41 20 00	Internal Patch I12	
:	:	
01 7F 20 00	Internal Patch I88	
01 7F 40 00	Internal Rhythm Setup	*1-4
02 00 10 00	Card Performance C01	*1-2
02 01 10 00	Card Performance C02	
:	:	
02 0F 10 00	Card Performance C16	
02 20 00 00	Card Rhythm Setup 2	*1-5
02 40 20 00	Card Patch C11	*1-3
02 41 20 00	Card Patch C12	
:	:	
02 7F 20 00	Card Patch C88	
02 7F 40 00	Card Rhythm Setup	*1-4

*1-1		System Common	
Offset address	Description		
00	0000 000a	Panel mode	0 - 1 (PERFORMANCE, PATCH)
01	0aaa aaaa	Master tune	1 - 127 (427.4 - 452.6)
02	0aaa aaaa	Key transpose	28 - 100
03	0000 000a	Transpose Switch	0 - 1
04	0000 000a	Reverb switch	0 - 1 (OFF, ON)
05	0000 000a	Chorus switch	0 - 1 (OFF, ON)
06	0000 000a	Hold polarity	0 - 1
07	0000 000a	Pedal 1 polarity	0 - 1
08	0000 00aa	Pedal 1 mode	0 - 3
09	0aaa aaaa	Pedal 1 assign	0 - 100
0A	0000 000a	Pedal 2 polarity	0 - 1
0B	0000 00aa	Pedal 2 mode	0 - 3
0C	0aaa aaaa	Pedal 2 assign	0 - 100
0D	0000 00aa	C1 mode	0 - 3
0E	0aaa aaaa	C1 assign	0 - 100
0F	0aaa aaaa	Aftertouch threshold	0 - 127
MIDI receive switch			
10	0000 000a	Volume	0 - 1 (OFF, ON)
11	0000 000a	Control change	0 - 1 (OFF, ON)
12	0000 000a	Channel pressure	0 - 1 (OFF, ON)
13	0000 000a	Modulation	0 - 1 (OFF, ON)
14	0000 000a	Pitch bend	0 - 1 (OFF, ON)
15	0000 000a	Program change	0 - 1 (OFF, ON)
16	0000 000a	Bank select	0 - 1 (OFF, ON)
MIDI transmit switch			

17	0000 000a	Volume	0 - 1
18	0000 000a	Control change	0 - 1
19	0000 000a	Channel pressure	0 - 1
1A	0000 000a	Modulation	0 - 1
1B	0000 000a	Bender	0 - 1
1C	0000 000a	Program change	0 - 1
1D	0000 000a	Bank select	0 - 1
1E	0000 aaaa	Patch receive channel	0 - 15 (1 - 16)
1F	000a aaaa	Patch transmit channel	0 - 17
20	000a aaaa	Control channel	0 - 16 (1 - 16, OFF)
1%	21	0000 000a	Output mode 0 - 1 (OUT2, OUT4)
1%	22	0000 000a	Rhythm edit key 0 - 1 (INT&MIDI, INT)
23	0000 0000	Scale tune switch	0 - 1 (OFF, ON)
24	0aaa aaaa	Scale Tune Part1 C	0 - 127 (-64 - +63)
25	:	:	C#
26	:	:	D
27	:	:	D#
28	:	:	E
29	:	:	F
2A	:	:	F#
2B	:	:	G
2C	:	:	G#
2D	:	:	A
2E	:	:	A#
2F	:	:	B
30	0aaa aaaa	Scale Tune Part2 C	0 - 127 (-64 - +63)
31	:	:	C#
32	:	:	D
33	:	:	D#
34	:	:	E
35	:	:	F
36	:	:	F#
37	:	:	G
38	:	:	G#
39	:	:	A
3A	:	:	A#
3B	:	:	B
3C	0aaa aaaa	Scale Tune Part3 C	0 - 127 (-64 - +63)
3D	:	:	C#
3E	:	:	D
3F	:	:	D#
40	:	:	E
41	:	:	F
42	:	:	F#
43	:	:	G
44	:	:	G#
45	:	:	A
46	:	:	A#
47	:	:	B
48	0aaa aaaa	Scale Tune Part4 C	0 - 127 (-64 - +63)
49	:	:	C#
4A	:	:	D
4B	:	:	D#
4C	:	:	E
4D	:	:	F
4E	:	:	F#
4F	:	:	G
50	:	:	G#
51	:	:	A
52	:	:	A#
53	:	:	B
54	0aaa aaaa	Scale Tune Part5 C	0 - 127 (-64 - +63)
55	:	:	C#
56	:	:	D
57	:	:	D#
58	:	:	E
59	:	:	F
5A	:	:	F#
5B	:	:	G
5C	:	:	G#

5D	:	:	A
5E	:	:	A#
5F	:	:	B
60	0aaa aaaa	Scale Tune Part6 C	0 - 127 (-64 - +63)
61	:	:	C#
62	:	:	D
63	:	:	D#
64	:	:	E
65	:	:	F
66	:	:	F#
67	:	:	G
68	:	:	G#
69	:	:	A
6A	:	:	A#
6B	:	:	B
6C	0aaa aaaa	Scale Tune Part7 C	0 - 127 (-64 - +63)
6D	:	:	C#
6E	:	:	D
6F	:	:	D#
70	:	:	E
71	:	:	F
72	:	:	F#
73	:	:	G
74	:	:	G#
75	:	:	A
76	:	:	A#
77	:	:	B
78	0aaa aaaa	Scale Tune Part8 C	0 - 127 (-64 - +63)
79	:	:	C#
7A	:	:	D
7B	:	:	D#
7C	:	:	E
7D	:	:	F
7E	:	:	F#
7F	:	:	G
01 00	:	:	G#
01 01	:	:	A
01 02	:	:	A#
01 03	:	:	B
01 04	0aaa aaaa	Scale Tune Patch C	0 - 127 (-64 - +63)
01 05	:	:	C#
01 06	:	:	D
01 07	:	:	D#
01 08	:	:	E
01 09	:	:	F
01 0A	:	:	F#
01 0B	:	:	G
01 0C	:	:	G#
01 0D	:	:	A
01 0E	:	:	A#
01 0F	:	:	B
01 10	0---	(Dummy)	
01 11	0aaa aaaa	Master volume	0 - 127
Total Size 00 00 01 12			

1-2 Performance

Offset	address	Description
00 00		Performance Common 1-2-1
08 00		Performance Part 1 1-2-2
09 00		Performance Part 2
0A 00		Performance Part 3
0B 00		Performance Part 4
0C 00		Performance Part 5
0D 00		Performance Part 6
0E 00		Performance Part 7
0F 00		Performance Part 8

1-2-1

Performance Common

Offset address	Description		
00	0aaa aaaa	Performance name 1	32 - 127
01	0aaa aaaa	Performance name 2	32 - 127
:	:	:	:
0B	0aaa aaaa	Performance name 12	32 - 127
0C	0000 00aa	Key mode	0 - 2
0D	0000 0aaa	Reverb type	0 - 7 (ROOM1, ROOM2, STAGE1, STAGE2, HALL1, HALL2, DELAY, PAN-DLY)
0E	0aaa aaaa	Reverb level	0 - 127
0F	0aaa aaaa	Reverb time	0 - 127
10	0aaa aaaa	Reverb feedback	0 - 127
11	0000 00aa	Chorus type	0 - 2 (CHORUS1, CHORUS2, CHORUS3)
12	0aaa aaaa	Chorus level	0 - 127
13	0aaa aaaa	Chorus depth	0 - 127
14	0aaa aaaa	Chorus rate	0 - 127
15	0aaa aaaa	Chorus feedback	0 - 127
16	0000 000a	Chorus output	0 - 1 (MIX, REV)
17	000a aaaa	Part 1 Voice reserve	0 - 28
18	000a aaaa	Part 2 Voice reserve	0 - 28
:	:	:	:
1E	000a aaaa	Part 8 Voice reserve	0 - 28
Total Size 00 00 00 1F			

Note: The sum of voice receives must be less than or equal 28.

1-2-2

Performance Part

Offset address	Description			
00	0000 000a	Transmit switch	0 - 1	
01	0000 aaaa	Transmit channel	0 - 15	
#	02	0000 aaaa	Transmit program change	0 - 128
		0000 bbbb		
#	04	0000 aaaa	Transmit volume	0 - 128
		0000 bbbb		
#	06	0000 aaaa	Transmit pan	0 - 128
		0000 bbbb		
08	0aaa aaaa	Transmit key range lower	0 - 127	
09	0aaa aaaa	Transmit key range upper	0 - 127	
0A	0aaa aaaa	Transmit key transpose	28 - 100	
0B	0aaa aaaa	Transmit velocity sense	1 - 127	
0C	0aaa aaaa	Transmit velocity max	0 - 127	
0D	0000 0aaa	Transmit velocity curve	0 - 6	
0E	0000 000a	Internal switch	0 - 1	
0F	0aaa aaaa	Internal key range lower	0 - 127	
10	0aaa aaaa	Internal key range upper	0 - 127	
11	0aaa aaaa	Internal key transpose	28 - 100	
12	0aaa aaaa	Internal velocity sense	1 - 127	
13	0aaa aaaa	Internal velocity max	0 - 127	
14	0000 0aaa	Internal velocity curve	0 - 6	
15	0000 000a	Receive switch	0 - 1 (OFF, ON)	
16	0000 aaaa	Receive channel	0 - 15 (1 - 16)	
#	17	0000 aaaa	Patch number	0 - 255
		0000 bbbb	(I01 - I64, C01 - C64, A01 - A64, B01 - B64)	
19	0aaa aaaa	Part level	0 - 127	
1A	0aaa aaaa	Part pan	0 - 127 (L64 - 63R)	
1B	0aaa aaaa	Part coarse tune	16 - 112 (-48 - +48)	
1C	0aaa aaaa	Part fine tune	14 - 114 (-50 - +50)	
1D	0000 000a	Reverb switch	0 - 1 (OFF, ON)	
1E	0000 000a	Chorus switch	0 - 1 (OFF, ON)	
1F	0000 000a	Receive program change	0 - 1 (OFF, ON)	
20	0000 000a	Receive volume	0 - 1	

			(OFF, ON)	
	21	0000 000a	Receive hold-1	0 - 1 (OFF, ON)
#	22	0000 00aa	Output select	0 - 2 (MN, SB, PAT)
	23	0000 00aa	Patch media	0 - 3 (BASIC, PRESET, EXP, PCM)
	24	0000 000a	Sequencer switch	0 - 1 (ON, OFF)
Total Size 00 00 00 25				

Note: The values of the transmit key range upper must be greater than or equal to the values of the transmit key range lower.

Note: The values of the internal key range upper must be greater than or equal to the values of the internal key range lower.

* 1 - 3 Patch

Offset address	Description		
00 00	Patch Common		1-3-1
08 00	Patch Tone 1		1-3-2
09 00	Patch Tone 2		
0A 00	Patch Tone 3		
0B 00	Patch Tone 4		

* 1 - 3 - 1 Patch Common

Offset address	Description		
00	0aaa aaaa	Patch name 1	32 - 127
01	0aaa aaaa	Patch name 2	32 - 127
:	:	:	:
0B	0aaa aaaa	Patch name 12	32 - 127
0C	0000 000a	Velocity switch	0 - 1 (OFF, ON)
0D	0000 0aaa	Reverb type	0 - 7 (ROOM1, ROOM2, STAGE1, STAGE2, HALL1, HALL2, DELAY, PAN-DLY)
0E	0aaa aaaa	Reverb level	0 - 127
0F	0aaa aaaa	Reverb time	0 - 127
10	0aaa aaaa	Delay feedback	0 - 127
11	0000 00aa	Chorus type	0 - 2 (CHORUS1, CHORUS2, CHORUS3)
12	0aaa aaaa	Chorus level	0 - 127
13	0aaa aaaa	Chorus depth	0 - 127
14	0aaa aaaa	Chorus rate	0 - 127
15	0aaa aaaa	Chorus feedback	0 - 127
16	0000 000a	Chorus output	0 - 1 (MIX, REV)
17	0aaa aaaa	Analog feel	0 - 127
18	0aaa aaaa	Patch level	0 - 127
19	0aaa aaaa	Patch pan	0 - 127 (L64 - 63R)
1A	0aaa aaaa	Bender range down	16 - 64 (-48 - 0)
1B	0000 aaaa	Bender range up	0 - 12
1C	0000 000a	Key assign	0 - 1 (POLY, SOLO)
1D	0000 000a	Solo legato	0 - 1 (OFF, ON)
1E	0000 000a	Portamento switch	0 - 1 (OFF, ON)
1F	0000 000a	Portamento mode	0 - 1 (LEGATO, NORMAL)
20	0000 000a	Portamento type	0 - 1 (TIME, RATE)
21	0aaa aaaa	Portamento time	0 - 127
Total Size 00 00 00 22			

Offset address	Description		
00 0000 00aa	Wave group	0 - 2	
		(INT, EXP, PCM)	
# 01 0000 aaaa	Wave number	0 - 254	
		(1 - 255)	
03 0000 000a	Tone switch	0 - 1	
		(OFF, ON)	
04 0000 000a	FXM switch	0 - 1	
		(OFF, ON)	
05 0000 aaaa	FXM depth	0 - 15	
		(1 - 16)	
06 0aaa aaaa	Velocity range lower	0 - 127	
07 0aaa aaaa	Velocity range upper	0 - 127	
08 0000 000a	Volume switch	0 - 1	
		(OFF, ON)	
09 0000 000a	Hold-1 switch	0 - 1	
		(OFF, ON)	
0A 0000 aaaa	Modulation 1 destination	0 - 12	
		(OFF, PITCH, CUTOFF, RESONANCE, LEVEL, PITCH LFO1, PITCH LFO2, TVF LFO1, TVF LFO2, TVA LFO1, TVA LFO2, LFO1 RATE, LFO2 RATE)	
0B 0aaa aaaa	Modulation 1 depth	1 - 127	
		(-63 - +63)	
0C 0000 aaaa	Modulation 2 destination	0 - 12	
		(OFF, PITCH, CUTOFF, RESONANCE, LEVEL, PITCH LFO1, PITCH LFO2, TVF LFO1, TVF LFO2, TVA LFO1, TVA LFO2, LFO1 RATE, LFO2 RATE)	
0D 0aaa aaaa	Modulation 2 depth	1 - 127	
		(-63 - +63)	
0E 0000 aaaa	Modulation 3 destination	0 - 12	
		(OFF, PITCH, CUTOFF, RESONANCE, LEVEL, PITCH LFO1, PITCH LFO2, TVF LFO1, TVF LFO2, TVA LFO1, TVA LFO2, LFO1 RATE, LFO2 RATE)	
0F 0aaa aaaa	Modulation 3 depth	1 - 127	
		(-63 - +63)	
10 0000 aaaa	Modulation 4 destination	0 - 12	
		(OFF, PITCH, CUTOFF, RESONANCE, LEVEL, PITCH LFO1, PITCH LFO2, TVF LFO1, TVF LFO2, TVA LFO1, TVA LFO2, LFO1 RATE, LFO2 RATE)	
11 0aaa aaaa	Modulation 4 depth	1 - 127	
		(-63 - +63)	
12 0000 aaaa	Aftertouch 1 destination	0 - 12	
		(OFF, PITCH, CUTOFF, RESONANCE, LEVEL, PITCH LFO1, PITCH LFO2, TVF LFO1, TVF LFO2, TVA LFO1, TVA LFO2, LFO1 RATE, LFO2 RATE)	
13 0aaa aaaa	Aftertouch 1 depth	1 - 127	
		(-63 - +63)	
14 0000 aaaa	Aftertouch 2 destination	0 - 12	
		(OFF, PITCH, CUTOFF, RESONANCE, LEVEL, PITCH LFO1, PITCH LFO2, TVF LFO1, TVF LFO2, TVA LFO1, TVA LFO2, LFO1 RATE, LFO2 RATE)	
15 0aaa aaaa	Aftertouch 2 depth	1 - 127	
		(-63 - +63)	
16 0000 aaaa	Aftertouch 3 destination	0 - 12	
		(OFF, PITCH, CUTOFF, RESONANCE, LEVEL, PITCH LFO1, PITCH LFO2, TVF LFO1, TVF LFO2, TVA LFO1, TVA LFO2, LFO1 RATE, LFO2 RATE)	
17 0aaa aaaa	Aftertouch 3 depth	1 - 127	
		(-63 - +63)	
18 0000 aaaa	Aftertouch 4 destination	0 - 12	
		(OFF, PITCH, CUTOFF, RESONANCE, LEVEL, PITCH LFO1, PITCH LFO2, TVF LFO1, TVF LFO2, TVA LFO1, TVA LFO2, LFO1 RATE, LFO2 RATE)	
19 0aaa aaaa	Aftertouch 4 depth	1 - 127	
		(-63 - +63)	
1A 0000 aaaa	Expression 1 destination	0 - 12	
		(OFF, PITCH, CUTOFF, RESONANCE, LEVEL, PITCH LFO1, PITCH LFO2, TVF LFO1, TVF LFO2, TVA LFO1, TVA LFO2, LFO1 RATE, LFO2 RATE)	
1B 0aaa aaaa	Expression 1 depth	1 - 127	
		(-63 - +63)	
1C 0000 aaaa	Expression 2 destination	0 - 12	
		(OFF, PITCH, CUTOFF, RESONANCE, LEVEL, PITCH LFO1, PITCH LFO2, TVF LFO1, TVF LFO2, TVA LFO1, TVA LFO2, LFO1 RATE, LFO2 RATE)	
1D 0aaa aaaa	Expression 2 depth	1 - 127	
		(-63 - +63)	
1E 0000 aaaa	Expression 3 destination	0 - 12	
		(OFF, PITCH, CUTOFF, RESONANCE, LEVEL, PITCH LFO1, PITCH LFO2, TVF LFO1, TVF LFO2, TVA LFO1, TVA LFO2, LFO1 RATE, LFO2 RATE)	
1F 0aaa aaaa	Expression 3 depth	1 - 127	
		(-63 - +63)	
20 0000 aaaa	Expression 4 destination	0 - 12	
		(OFF, PITCH, CUTOFF, RESONANCE, LEVEL, PITCH LFO1, PITCH LFO2, TVF LFO1, TVF LFO2, TVA LFO1, TVA LFO2, LFO1 RATE, LFO2 RATE)	
21 0aaa aaaa	Expression 4 depth	1 - 127	
		(-63 - +63)	
22 0000 0aaa	LFO-1 form	0 - 5	
		(TRI, SIN, SAW, SQR, RND1, RND2)	
23 0000 0aaa	LFO-1 offset	0 - 4	
		(-100, -50, 0, +50, +100)	
24 0000 000a	LFO-1 synchro	0 - 1	
		(OFF, ON)	
25 0aaa aaaa	LFO-1 rate	0 - 127	
26 0000 aaaa	LFO-1 delay	0 - 128	
		(0 - 127, KEY-OFF)	
28 0000 000a	LFO-1 fade polarity	0 - 1	
		(IN, OUT)	
29 0aaa aaaa	LFO-1 fade time	0 - 127	
2A 0aaa aaaa	LFO-1 pitch depth	1 - 127	
		(-63 - +63)	
2B 0aaa aaaa	LFO-1 TVF depth	1 - 127	
		(-63 - +63)	
2C 0aaa aaaa	LFO-1 TVA depth	1 - 127	
		(-63 - +63)	
2D 0000 0aaa	LFO-2 form	0 - 5	
		(TRI, SIN, SAW, SQR, RND1, RND2)	
2E 0000 0aaa	LFO-2 offset	0 - 4	
		(-100, -50, 0, +50, +100)	
2F 0000 000a	LFO-2 synchro	0 - 1	
		(OFF, ON)	
30 0aaa aaaa	LFO-2 rate	0 - 127	
31 0000 aaaa	LFO-2 delay	0 - 128	
		(0 - 127, KEY-OFF)	
33 0000 000a	LFO-2 fade polarity	0 - 1	
		(IN, OUT)	
34 0aaa aaaa	LFO-2 fade time	0 - 127	
35 0aaa aaaa	LFO-2 pitch depth	1 - 124	
		(-63 - +63)	
36 0aaa aaaa	LFO-2 TVF depth	1 - 127	
		(-63 - +63)	
37 0aaa aaaa	LFO-2 TVA depth	1 - 127	
		(-63 - +63)	
38 0aaa aaaa	Pitch coarse	16 - 112	
		(-48 - +48)	
39 0aaa aaaa	Pitch fine	14 - 114	
		(-50 - +50)	
3A 0000 aaaa	Random pitch	0 - 15	
		(0, 5, 10, 20, 30, 40, 50, 70, 100, 200, 300, 400, 500, 600, 800, 1200)	
3B 0000 aaaa	Pitch key follow	0 - 15	
		(-100, -70, -50, -30, -10, 0, +10, +20, +30, +40, +50, +70, +100, +120, +150, +200)	
3C 0aaa aaaa	P-ENV velocity sense	1 - 127	
		(-63 - +63)	
3D 0000 aaaa	P-ENV T1 velocity	0 - 14	
		(-100, -70, -50, -40, -30, -20, -10, 0, +10, +20, +30, +40, +50, +70, +100)	
3E 0000 aaaa	P-ENV T4 velocity	0 - 14	
		(-100, -70, -50, -40, -30, -20, -10, 0, +10, +20, +30, +40, +50, +70, +100)	
3F 0000 aaaa	P-ENV time key follow	0 - 14	
		(-100, -70, -50, -40, -30, -20, -10, 0, +10, +20, +30, +40, +50, +70, +100)	
40 0aaa aaaa	P-ENV depth	52 - 76	
		(-12 - +12)	

41	0aaa aaaa	P-ENV time 1	0 - 127	
42	0aaa aaaa	P-ENV level 1	1 - 127	
			(-63 - +63)	
43	0aaa aaaa	P-ENV time 2	0 - 127	
44	0aaa aaaa	P-ENV level 2	1 - 127	
			(-63 - +63)	
45	0aaa aaaa	P-ENV time 3	0 - 127	
46	0aaa aaaa	P-ENV level 3	1 - 127	
			(-63 - +63)	
47	0aaa aaaa	P-ENV time 4	0 - 127	
48	0aaa aaaa	P-ENV level 4	1 - 127	
			(-63 - +63)	

49	0000 00aa	TVF mode	0 - 2	
			(OFF, LFF, HPF)	
4A	0aaa aaaa	Cutoff frequency	0 - 127	
4B	0aaa aaaa	Resonance	0 - 127	
4C	0000 000a	Resonance mode	0 - 1	
			(SOFT, HARD)	
4D	0000 aaaa	TVF key follow	0 - 15	
			(-100, -70, -50, -30, -10, 0, +10, +20, +30, +40, +50, +70, +100, +120, +150, +200)	
4E	0000 0aaa	TVF-ENV velocity curve	0 - 6	
			(1 - 7)	
4F	0aaa aaaa	TVF-ENV velocity sense	1 - 127	
			(-63 - +63)	
50	0000 aaaa	TVF-ENV T1 velocity	0 - 14	
			(-100, -70, -50, -40, -30, -20, -10, 0, +10, +20, +30, +40, +50, +70, +100)	
51	0000 aaaa	TVF-ENV T4 velocity	0 - 14	
			(-100, -70, -50, -40, -30, -20, -10, 0, +10, +20, +30, +40, +50, +70, +100)	
52	0000 aaaa	TVF-ENV time key follow	0 - 14	
			(-100, -70, -50, -40, -30, -20, -10, 0, +10, +20, +30, +40, +50, +70, +100)	
53	0aaa aaaa	TVF-ENV depth	1 - 127	
			(-63 - +63)	
54	0aaa aaaa	TVF-ENV time 1	0 - 127	
55	0aaa aaaa	TVF-ENV level 1	0 - 127	
56	0aaa aaaa	TVF-ENV time 2	0 - 127	
57	0aaa aaaa	TVF-ENV level 2	0 - 127	
58	0aaa aaaa	TVF-ENV time 3	0 - 127	
59	0aaa aaaa	TVF-ENV level 3	0 - 127	
5A	0aaa aaaa	TVF-ENV time 4	0 - 127	
5B	0aaa aaaa	TVF-ENV level 4	0 - 127	

5C	0aaa aaaa	Level	0 - 127	
5D	0000 aaaa	TVA key follow	0 - 14	
			(-100, -70, -50, -40, -30, -20, -10, 0, +10, +20, +30, +40, +50, +70, +100)	
#	5E	0000 aaaa	Pan	0 - 128
		0000 bbbb		(L64 - 63R, RND)
60	0000 aaaa	Panning key follow	0 - 14	
			(-100, -70, -50, -40, -30, -20, -10, 0, +10, +20, +30, +40, +50, +70, +100)	
61	0000 00aa	TVA delay mode	0 - 2	
			(NORMAL, HOLD, PLAY-MATE)	
#	62	0000 aaaa	TVA delay time	0 - 128
		0000 bbbb		(0 - 127, KEY-OFF)
64	0000 0aaa	TVA-ENV velocity curve	0 - 6	
			(1 - 7)	
65	0aaa aaaa	TVA-ENV velocity sense	1 - 127	
			(-63 - +63)	
66	0000 aaaa	TVA-ENV T1 velocity	0 - 14	
			(-100, -70, -50, -40, -30, -20, -10, 0, +10, +20, +30, +40, +50, +70, +100)	
67	0000 aaaa	TVA-ENV T4 velocity	0 - 14	
			(-100, -70, -50, -40, -30, -20, -10, 0, +10, +20, +30, +40, +50, +70, +100)	
68	0000 aaaa	TVA-ENV time key follow	0 - 14	
			(-100, -70, -50, -40, -30, -20, -10, 0, +10, +20, +30, +40, +50, +70, +100)	
69	0aaa aaaa	TVA-ENV time 1	0 - 127	
6A	0aaa aaaa	TVA-ENV level 1	0 - 127	
6B	0aaa aaaa	TVA-ENV time 2	0 - 127	
6C	0aaa aaaa	TVA-ENV level 2	0 - 127	
6D	0aaa aaaa	TVA-ENV time 3	0 - 127	
6E	0aaa aaaa	TVA-ENV level 3	0 - 127	
6F	0aaa aaaa	TVA-ENV time 4	0 - 127	

70	0aaa aaaa	Dry level	0 - 127	
71	0aaa aaaa	Reverb send level	0 - 127	
72	0aaa aaaa	Chorus send level	0 - 127	
X	73	0000 000a	Output select	0 - 1

				(MAIN, SUB)
	74	0000 800a	Redamper switch	0 - 1
				(OFF, ON)

Total Size		00 00 00 75		

Note: The values of the velocity range upper must be greater than or equal to the values of the velocity range lower.

* 1 - 4 Rhythm Setup 1

Offset	address	Description	
	00 00	Rhythm Note for Key# 36 (C 2)	1-4-1
	01 00	:	37 (C#2)
	02 00	:	38 (D 2)
	03 00	:	39 (D#2)
	04 00	:	40 (E 2)
	05 00	:	41 (F 2)
	06 00	:	42 (F#2)
	07 00	:	43 (G 2)
	08 00	:	44 (G#2)
	09 00	:	45 (A 2)
	0A 00	:	46 (A#2)
	0B 00	:	47 (B 2)
	0C 00	:	48 (C 3)
	0D 00	:	49 (C#3)
	0E 00	:	50 (D 3)
	0F 00	:	51 (D#3)
	10 00	:	52 (E 3)
	11 00	:	53 (F 3)
	12 00	:	54 (F#3)
	13 00	:	55 (G 3)
	14 00	:	56 (G#3)
	15 00	:	57 (A 3)
	16 00	:	58 (A#3)
	17 00	:	59 (B 3)
	18 00	:	60 (C 4)
	19 00	:	61 (C#4)
	1A 00	:	62 (D 4)
	1B 00	:	63 (D#4)
	1C 00	:	64 (E 4)
	1D 00	:	65 (F 4)
	1E 00	:	66 (F#4)
	1F 00	:	67 (G 4)
	20 00	:	68 (G#4)
	21 00	:	69 (A 4)
	22 00	:	70 (A#4)
	23 00	:	71 (B 4)
	24 00	:	72 (C 5)
	25 00	:	73 (C#5)
	26 00	:	74 (D 5)
	27 00	:	75 (D#5)
	28 00	:	76 (E 5)
	29 00	:	77 (F 5)
	2A 00	:	78 (F#5)
	2B 00	:	79 (G 5)
	2C 00	:	80 (G#5)
	2D 00	:	81 (A 5)
	2E 00	:	82 (A#5)
	2F 00	:	83 (B 5)
	30 00	:	84 (C 6)
	31 00	:	85 (C#6)
	32 00	:	86 (D 6)
	33 00	:	87 (D#6)
	34 00	:	88 (E 6)
	35 00	:	89 (F 6)
	36 00	:	90 (F#6)
	37 00	:	91 (G 6)
	38 00	:	92 (G#6)
	39 00	:	93 (A 6)
	3A 00	:	94 (A#6)
	3B 00	:	95 (B 6)
	3C 00	:	96 (C 7)

* 1 - 4 - 1 Rhythm Note 1

Offset	address	Description		
	00	0000 00aa	Wave group	0 - 2
				(INT, EXP, PCM)

#	01	0000 aaaa	Wave number	0 - 254
		0000 bbbb		(1 - 255)
	03	0000 000a	Tone switch	0 - 1
				(OFF, ON)
	04	0aaa aaaa	Coarse tune	0 - 127
				(C-1 - G9)
	05	000a aaaa	Mute group	0 - 31
				(OFF, 1 - 31)
	06	0000 000a	Envelope mode	0 - 1
				(NO-SUSTAIN, SUSTAIN)
	07	0aaa aaaa	Pitch fine	14 - 114
				(-50 - +50)
	08	0000 aaaa	Random pitch	0 - 15
				(0, 5, 10, 20, 30, 40, 50, 70, 100, 200, 300, 400, 500, 600, 800, 1200)
	09	0000 aaaa	Bender range	0 - 12
	0A	0aaa aaaa	P-ENV velocity sense	1 - 127
				(-63 - +63)
	0B	0000 aaaa	P-ENV time velocity sense	0 - 14
				(-100, -70, -50, -40, -30, -20, -10, 0, +10, +20, +30, +40, +50, +70, +100)
	0C	0aaa aaaa	P-ENV depth	52 - 76
				(-12 - +12)
	0D	0aaa aaaa	P-ENV time 1	0 - 127
	0E	0aaa aaaa	P-ENV level 1	1 - 127
				(-63 - +63)
	0F	0aaa aaaa	P-ENV time 2	0 - 127
	10	0aaa aaaa	P-ENV level 2	1 - 127
				(-63 - +63)
	11	0aaa aaaa	P-ENV time 3	0 - 127
	12	0aaa aaaa	P-ENV level 3	1 - 127
				(-63 - +63)
	13	0aaa aaaa	P-ENV time 4	0 - 127
	14	0aaa aaaa	P-ENV level 4	1 - 127
				(-63 - +63)
	15	0000 00aa	TVF mode	0 - 2
				(OFF, LPF, HPF)
	16	0aaa aaaa	Cutoff frequency	0 - 127
	17	0aaa aaaa	Resonance	0 - 127
	18	0000 000a	Resonance mode	0 - 1
				(SOFT, HARD)
	19	0aaa aaaa	TVF-ENV velocity sense	1 - 127
				(-63 - +63)
	1A	0000 aaaa	TVF-ENV time velocity sense	0 - 14
				(-100, -70, -50, -40, -30, -20, -10, 0, +10, +20, +30, +40, +50, +70, +100)
	1B	0aaa aaaa	TVF-ENV depth	1 - 127
				(-63 - +63)
	1C	0aaa aaaa	TVF-ENV time 1	0 - 127
	1D	0aaa aaaa	TVF-ENV level 1	0 - 127
	1E	0aaa aaaa	TVF-ENV time 2	0 - 127
	1F	0aaa aaaa	TVF-ENV level 2	0 - 127
	20	0aaa aaaa	TVF-ENV time 3	0 - 127
	21	0aaa aaaa	TVF-ENV level 3	0 - 127
	22	0aaa aaaa	TVF-ENV time 4	0 - 127
	23	0aaa aaaa	TVF-ENV level 4	0 - 127
	24	0aaa aaaa	Level	0 - 127
#	25	0000 aaaa	Pan	0 - 128
		0000 bbbb		(L64 - 63R, RND)
	27	0aaa aaaa	TVA-ENV velocity sense	1 - 127
				(-63 - +63)
	28	0000 aaaa	TVA-ENV time velocity sense	0 - 14
				(-100, -70, -50, -40, -30, -20, -10, 0, +10, +20, +30, +40, +50, +70, +100)
	29	0aaa aaaa	TVA-ENV time 1	0 - 127
	2A	0aaa aaaa	TVA-ENV level 1	0 - 127
	2B	0aaa aaaa	TVA-ENV time 2	0 - 127
	2C	0aaa aaaa	TVA-ENV level 2	0 - 127
	2D	0aaa aaaa	TVA-ENV time 3	0 - 127
	2E	0aaa aaaa	TVA-ENV level 3	0 - 127
	2F	0aaa aaaa	TVA-ENV time 4	0 - 127
	30	0aaa aaaa	Dry level	0 - 127
	31	0aaa aaaa	Reverb send level	0 - 127
	32	0aaa aaaa	Chorus send level	0 - 127
%	33	0000 000a	Output select	0 - 1
				(MAIN, SUB)
Total Size : 00 00 00 34				

* 1 - 5

Rhythm Setup 2

Offset	address	Description
38 00	Rhythm Note for Key#	28 (E 1) 1-5-1
39 00	:	29 (F 1)
3A 00	:	30 (F#1)
3B 00	:	31 (G 1)
3C 00	:	32 (G#1)
3D 00	:	33 (A 1)
3E 00	:	34 (A#1)
3F 00	:	35 (B 1)
40 00	:	97 (C#7)
41 00	:	98 (D 7)
42 00	:	99 (D#7)
43 00	:	100 (E 7)
44 00	:	101 (F 7)
45 00	:	102 (F#7)
46 00	:	103 (G 7)

* 1 - 5 - 1

Rhythm Note 2

Same as 1 - 4 - 1.

Address Map

Address	Block	Sub Block	Reference
00 00 00 00	System Common		1-1
00 00 10 00	Temporary Performance	Common	1-2-1
		Part 1	1-2-2
		:	
		Part 8	
00 00 20 00	Performance Mode Temporary Patch	Part 1 Common	1-3-1
		:	
		Tone 1	1-3-2
		:	
		Part 7	
		:	
		Tone 4	
00 07 40 00	Temporary 1 Rhythm Setup	Note# 36	1-4-1
		:	
		Note# 96	
00 08 20 00	Patch Mode Temporary Patch	Common	1-3-1
		:	
		Tone 1	1-3-2
		:	
		Tone 4	
00 20 38 00	Temporary Rhythm Setup 2	Note# 28	1-5-1
		:	
		Note# 35	
		:	
		Note# 97	
		:	
		Note# 103	
01 00 10 00	Internal Memory Performance	I01 Common	1-2-1
		:	
		Part 1	1-2-2
		:	
		I16	
		:	
		Part 8	

01 20 38 00	Internal Memory	Note# 28		1-5-1
	Rhythm Setup 2	:		
		Note# 35		
		Note# 97		
		:		
		Note# 103		
01 40 20 00	Internal Memory	I11	Common	1-3-1
	Patch	:		
		Tone 1		1-3-2
		I88		
		:		
		Tone 4		
01 7F 40 00	Internal Memory	Note# 36		1-4-1
	Rhythm Setup 2	:		
		Note# 96		
02 00 10 00	Card Memory	C01	Common	1-2-1
	Performance	:		
		Part 1		1-2-2
		C16		
		:		
		Part 8		
02 20 38 00	Card Memory	Note# 28		1-5-1
	Rhythm Setup 2	:		
		Note# 35		
		Note# 97		
		:		
		Note# 103		
02 40 20 00	Card Memory	C11	Common	1-3-1
	Patch	:		
		Tone 1		1-3-1
		C88		
		:		
		Tone 4		
02 7F 40 00	Card Memory	Note# 36		1-4-1
	Rhythm Setup 1	:		
		Note# 96		

2 GS

< MODEL ID = 42H >

Start address	Description
40 10 40	Scale Tune Part8 2-1
40 11 40	Part1
40 12 40	Part2
40 13 40	Part3
40 14 40	Part4
40 15 40	Part5
40 16 40	Part6
40 17 40	Part7

2-1 Scale Tune

Offset address	Description
00	0aaa aaaa Scale Tune C 00 - 127 (-64 - +63)
01	: : C#
02	: : D
03	: : D#
04	: : E
05	: : F
06	: : F#
07	: : G
08	: : G#
09	: : A
0A	: : A#
0B	: : B
Total Size 00 00 00 0C	

Note: If you send the scale tune data, must send from "C" to "B" (1 oct) per packet.

/Example of DT1 application /

To set the scale tune (C-B) of the performance part 1 Arabia, send the data as follows:

FDH 41H 10H 42H 12H 40H 11H 40H 3AH 6DH 3EH 34H 0DH 38H 6BH 3CH
6FH 40H 36H 0FH 50H F7H

● Table A - 1 : Decimal to Hexadecimal

The MIDI messages are expressed in hexadecimal configured in 7 bits. This table is useful when you read or write MIDI messages.

(D) = decimal
(H) = hexadecimal

(D)	(H)	(D)	(H)	(D)	(H)	(D)	(H)
0	00H	32	20H	64	40H	96	60H
1	01H	33	21H	65	41H	97	61H
2	02H	34	22H	66	42H	98	62H
3	03H	35	23H	67	43H	99	63H
4	04H	36	24H	68	44H	100	64H
5	05H	37	25H	69	45H	101	65H
6	06H	38	26H	70	46H	102	66H
7	07H	39	27H	71	47H	103	67H
8	08H	40	28H	72	48H	104	68H
9	09H	41	29H	73	49H	105	69H
10	0AH	42	2AH	74	4AH	106	6AH
11	0BH	43	2BH	75	4BH	107	6BH
12	0CH	44	2CH	76	4CH	108	6CH
13	0DH	45	2DH	77	4DH	109	6DH
14	0EH	46	2EH	78	4EH	110	6EH
15	0FH	47	2FH	79	4FH	111	6FH
16	10H	48	30H	80	50H	112	70H
17	11H	49	31H	81	51H	113	71H
18	12H	50	32H	82	52H	114	72H
19	13H	51	33H	83	53H	115	73H
20	14H	52	34H	84	54H	116	74H
21	15H	53	35H	85	55H	117	75H
22	16H	54	36H	86	56H	118	76H
23	17H	55	37H	87	57H	119	77H
24	18H	56	38H	88	58H	120	78H
25	19H	57	39H	89	59H	121	79H
26	1AH	58	3AH	90	5AH	122	7AH
27	1BH	59	3BH	91	5BH	123	7BH
28	1CH	60	3CH	92	5CH	124	7CH
29	1DH	61	3DH	93	5DH	125	7DH
30	1EH	62	3EH	94	5EH	126	7EH
31	1FH	63	3FH	95	5FH	127	7FH

- * The decimal value of MIDI channel, bank select, program change, etc is the decimal number in the table plus 1.
- * In the hexadecimal notation in configured 7 bits, the maximum data of 1 byte is 128. If the data is more than 128, used plural bytes.
- * The signed value is 00H = -64, 40H = ±0, 7FH = +63. In decimal notation, the value is the decimal number in the table minus 64.
The signed value of dual bytes is 00 00H = -8192, 40 40H = ±0, 7F 7FH = 8191. For example, converted aaH bbH (hex) to decimal to the following:
aa bbH - 40H 00H = aa x 128 + bb - 64 x 128.

● table A - 2 : ASCII code

Patch Name and Performance Name of MIDI data are described the ASCII code in the table below.

(H) = hexadecimal

Character (H)	Character (H)	Character (H)
SP	20H	
A	41H	a
B	42H	b
C	43H	c
D	44H	d
E	45H	e
F	46H	f
G	47H	g
H	48H	h
I	49H	i
J	4AH	j
K	4BH	k
L	4CH	l
M	4DH	m
N	4EH	n
O	4FH	o
P	50H	p
Q	51H	q
R	52H	r
S	53H	s
T	54H	t
U	55H	u
V	56H	v
W	57H	w
X	58H	x
Y	59H	y
Z	5AH	z

Note: "SP" is space.

MIDI Implementation Chart

Function ...		Transmitted	Recognized	Remarks
Basic Channel	Default	1-16	1-16	Memorized
	Changed	1-16	1-16	
Mode	Default	Mode 3	Mode 3	
	Messages Altered	X *****	Mode 3, 4 (m=1)	
Note Number	Default	0-127	0-127	
	True Voice	*****	0-127	
Velocity	Note ON	○	○	
	Note OFF	○	○	
After Touch	Key's	X	X	
	Ch's	○	○	
Pitch Bender		○	○	Resolution : 9 bit
Control Change	0-95	○*1	○*1	Bank select Modulation Portamento time Data entry Volume Panpot Expression Hold1 Portamento Reverb Chorus
	0 1 5 6, 38 7 10 11 64 65 91 93		○*1 ○*1 ○*1 ○*1 ○*1 ○*1 ○*1 ○*1 ○*1 ○*1 ○*1	
	100, 101 121	X X	○ ○	RPN LSB, MSB Reset all controllers
Prog Change	True #	○*1 *****	○*1 0-127	
System Exclusive		○	○	
System Common	Song Pos	X	X	
	Song Sel	X	X	
	Tune	X	X	
System Real Time	Clock	X	X	
	Commands	X	X	
Aux Messages	Local ON/OFF	X	○	
	All Notes OFF	X	○ (123-127)	
	Active Sense	○	○	
	Reset	X	X	
Notes		*1 ○, X can be selectable.		

Mode 1 : OMNI ON, POLY
Mode 3 : OMNI OFF, POLY

Mode 2 : OMNI ON, MONO
Mode 4 : OMNI OFF, MONO

○ : Yes
X : No

■ How to read a MIDI Implementation Chart

○ : MIDI messages that can be transmitted or received.

× : MIDI messages that cannot be transmitted or received.

● Basic Channel

The MIDI channel for transmitting(or receiving) MIDI messages can be specified over this range. The MIDI channel setting is remembered even when the power is turned off.

● Mode

Most recent keyboard use mode 3(omni off, poly).

Reception : MIDI messages are received only on the specified channels, and played polyphonically.

Transmission : All MIDI messages are transmitted on the specified MIDI channel.

※ "Mode" refers to MIDI Mode messages.

● Note Number

This is the range of note numbers that can be transmitted(or received). Note number 60 is middle C(C4).

● Velocity

This is the range over which velocity can be transmitted(or received) by Note On and Note Off messages.

● Aftertouch

Key's : Polyphonic Key Pressure

Ch's : Channel Pressure

● Pitch Bend

The bender range setting of each Tone determines the range of pitch change caused by Pitch Bender messages. When set to 0, Pitch Bender messages will be ignored.

● Control Change

This indicates the control numbers that can be transmitted(or received), and what they will control. For details, refer to the MIDI implementation.

● Program Change

The program numbers in the chart indicate the actual data.(This is one less than the Pitch and Tone program numbers.)

● Exclusive

Exclusive message reception can be turned On/Off.

● Common, Real time

These MIDI messages are used to synchronize sequencers and rhythm machines. The JV-90 does not use these messages.

● Aux messages

These messages are mainly used to keep a MIDI system running correctly. Active sensing transmission can be turned on / off.

6.Index

[A]

Aftertouch	17,41,43,54,112,113
Aftertouch Control	54
Aftertouch Threshold	42,112
Analog feel	52
Assign mode	53,113

[B]

Bank/number	7
Bender range	53,113
Bender/modulation lever	9,17,43,113
Bulk dump	96

[C]

C1 slider	9,17,41,112
Chorus	6,51,80,115
Chorus depth	45,51,80,115
Chorus feedback	51,80,115
Chorus level	51,80,115
Chorus rate	45,51,80,115
Chorus send depth	115
Chorus send level	51,80,109,115
Chorus switch (button)	6,76
Chorus type	51,68,80,110
Coarse tune	34,57,76,83,109,114
Command	87
Common	50,66,67
Compare	90
Control	41,53,81,113
Control change	41,54,81
Control channel	43,103
Copy	91,96
Cursor	18
Cutoff	60,84,109,114
Cutoff key follow	60
C.C	→ Control change

[D]

DATA card	8,27,88,95
Delay	52,69,81,110,115
Delay feedback	52,69,81,115
Device ID number	44,96
Dry level	51,80

[E]

Edit	48,65,78,113
Effect	6,45,51,68,80,110,114
Envelope mode	81
Envelope time key follow	59,61,64
Exclusive message	44,96,99
Exclusive protect	99
Exclusive receive switch	44
Expansion board	→ Voice expansion board → Wave expansion board
Expression control	54
Expression pedal	8,12,54

[F]

Factory setting	127
Filter LFO depth	57
Filter type	59,84
Fine tune	57,76,83,109,114
Foot pedal	→ Pedal 1/2
Function button	7
FXM(Frequency X — modulation)	55

[G]

GS reset	104
----------------	-----

[H]

Hold	13,23,54,77,112
Hold1	33,54,77
Hold1 control switch	54
Hold1 receive switch	77

[I]

Initialize	94,130
Internal max velocity	74
Internal memory	26,31,95,97,99
Internal protect	99
Internal transpose	35,74
Internal velocity curve	74
Internal velocity sensitivity	74
Internal zone	22,31,73
Internal zone key range	73
Int.	→ Internal

[J]

JV — 80 compatible preset 130

[K]

Key assign 53,113
Key mode 67
Key number 37,79
Key range 70,73

[L]

Layer mode 67
LCD Contrast 38,111
Legato 53
Level 33,38,50,52,69,75,81,85,108,111
Level key follow 62
Level LFO depth 57
LFO 56,57
LFO delay time 56
LFO depth 57
LFO fade mode 56
LFO fade time 56
LFO offset 56
LFO rate 56
LFO synchro 56
LFO waveform 56
Local switch 42,43,66,75
LSB 46,111

[M]

Master key shift 111
Master level 111
Master pan 111
Master tune 38,111
Max velocity 71,74
MIDI 8,22,32,42,55,96,104,112
MIDI receive channel 42,76,108,113
MIDI receive switch 32,44,66,77,106,113
MIDI transmit channel 42,71,108,110
MIDI transmit switch 32,66,72
Mode button 6
Modulation 32,43,113
Modulation control 54
Modulation depth 113
Modulation lever 9,17

MSB 46,111
Mute group 82

[O]

Offset 56,113
Output mode 41,112
Output switch 52,68,81

[P]

Page 7
Pan 33,34,50,62,72,75,85,108,111
Panic 22
Panning key follow 62
Parameter slider 6,48,66
Part 31,65,75,105,106
Part coarse tune 34,76,109,114
Part fine tune 76,109,114
Part information 32
Part level 75,108
Part pan 75,108
Part switch 6,66
Patch 6,16,26,105,107
Patch chorus 51
Patch common copy 92
Patch common parameter 50
Patch edit mode 48
Patch effects 51
Patch group (buttons) 7,16
Patch initialize 94
Patch level 50
Patch MIDI 42
Patch name 50
Patch pan 50
Patch play mode 16
Patch receive channel 42
Patch reverb 52
Patch select 34,90,106
Patch tone copy 92
Patch write 90
PCM card 8,16,27,55,82
Pedal 1/2 8,12,41,54,112
Performance 18,31,65
Performance chorus 68,80
Performance common copy 92
Performance common parameter 67
Performance edit mode 65
Performance effects 45,80

Performance initialize	94
Performance MIDI	43
Performance name	67
Performance part copy	91
Performance play mode	18,31
Performance reverb	69,80
Performance write	88
Pitch	57,83
Pitch bender	9,17,41,43,53,81,113
Pitch envelope	59,83
Pitch envelope depth	58,83
Pitch envelope time key follow	59
Pitch key follow	58
Pitch LFO depth	57
Pitch shift coarse	57,83
Pitch shift fine	57,83
Pitch velocity attack time sensitivity	58
Pitch velocity envelope level sensitivity	58,83
Pitch velocity envelope time sensitivity	83
Pitch velocity release time sensitivity	58
Poly	53,113
Portamento	53
Power up mode	38
Presence Control	9
Program change number	46,110
Program change receive switch	76
Program change	43,46,72,76,110,112
Protect	88,99
P.C	→ Program change

[R]

Random pitch depth	57,83
Receive channel	42,76,108
Receive MIDI	43
Receive switch	32,44,77,106
Resonance	60,84,109,114
Resonance mode	60,84
Reverb	6,51,80,109,115
Reverb level	45,52,81,115
Reverb send level	51,80,109,115
Reverb switch (button)	6,76
Reverb time	45,52,69,81,115
Reverb type	52,69,81,110
Re — damp switch	54
Rhythm	18,37,78
Rhythm edit mode	78
Rhythm key copy	93
Rhythm key initialize	94
Rhythm play mode	37

Rhythm set	37,78,108
Rhythm set initialize	94
Rhythm set write	90
Rhythm tone	37,79
RX PARTSWITCH	44,113
RX switch	32
Rx.	→ Receive

[S]

Scale tune	40
Single mode	67
Solo	53
System common parameter	38

[T]

Temporary area	26,31
Threshold	42,112
Tone	20,49
Tone delay	63
Tone level	62,85
Tone select switch	49,79
Tone switch	6,27,37,50,82
Transmit channel	42,71,110
Transmit max velocity	71
Transmit MIDI	43,112
Transmit pan	34,72
Transmit program change(P.C)	43,72,112
Transmit switch	32,34,66,72
Transmit transpose	34,70
Transmit velocity curve	71
Transmit velocity sensitivity	71
Transmit volume	34,72
Transmit zone	70
Transmit zone key range	70
Transpose	34,35,38,70,74,111
Tune	34,38,39,109,111,114
TVA	62,85
TVA envelope	63,86
TVA envelope time key follow	64
TVA level key follow	62
TVA velocity attack time sensitivity	63
TVA velocity curve type	62
TVA velocity level sensitivity	62,85
TVA velocity release time sensitivity	63
TVF	20,84,114
TVF cutoff frequency	60,84,109,114
TVF cutoff key follow	60

TVF envelope	61,84
TVF envelope depth	60,84
TVF envelope time key follow	61
TVF resonance	60,84,109,114
TVF velocity attack time sensitivity	61
TVF velocity curve type	61
TVF velocity envelope level sensitivity	61,84
TVF velocity release time sensitivity	61
TVF TVA envelope attack	109,114
TVF TVA envelope decay	109,114
TVF TVA envelope release	109,114
TX switch	32
Tx.	→ Transmit

[U]

User memory	99
-------------------	----

[V]

Velocity	17
Velocity attack time sensitivity	58,61,63
Velocity curve type	61,62,71,74
Velocity envelope level sensitivity	58,61,83,84
Velocity envelope time sensitivity	83
Velocity range	50
Velocity release time sensitivity	58,61,63
Velocity sense depth	113
Velocity sense offset	113
Velocity sensitivity	71,74
Velocity switch	62
Velocity time sensitivity	84,85
Vibrato	109,110
Voice expansion board	6,102
Voice expansion edit mode	102,113
Voice expansion mode	6
Voice expansion play mode	102,105,106
Voice reserve	76,108
Volume	9,13,23,33,34,72,112
Volume control switch	53
Volume receive switch	43,77
V — EXP	→ Voice expansion
V — EXP MIDI IN Selector Switch	98,102-104

[W]

Wave expansion board	2,37,55,82
Wave group	37,55,82
Wave number	37,55,82,126
Waveform	20,37,55,82,126
Write	88
Write mode	87
Write protect	99
W — EXP	→ Wave expansion

7. Specifications

JV - 90 : Expandable Synthesizer

● Keyboard

76 keys(with Velocity and Channel Aftertouch)

● Maximum Polyphony :28voices

● Memory

Factory

Patch : 256
Performance : 64
Rhythm Set : 4

Internal

Patch : 64
Performance : 16
Rhythm Set : 1

DATA Card(option)

Patch : 64
Performance : 16
Rhythm Set : 1

● Effects

Chorus : 3types
Reverb : 8types

● Display

40 characters, 2 lines (Backlit LCD)

● Connectors

Output jacks : Mix L(Mono)/R, V - Exp L/R
Stereo headphone jack
Head jack
Pedal jacks (1,2)
MIDI Connectors (IN, OUT, THRU, V - EXP IN)
Card Slots (PCM Card, DATA Card)

● Dimensions

1200 X 305 X 85 mm
47 - 1/4 X 12 X 3 - 3/8 inches

● Weight

9.9kg(21lbs 13oz)

● Power Consumption

21W (117V), 21W (230V), 21W (240V)

● Accessories

Owner's Manual
Power cord (230V, 240V only)

● Options

DATA card : M - 256E
PCM card : SO - PCM1 series
DATA(ROM)card : PN - JV80 series
Wave expansion board : SR - JV80 series
Voice expansion board : VE series

*In the interest of product development, the specifications and/or appearance of this unit are subject to change without prior notice.



For Nordic Countries

Apparatus containing Lithium batteries

ADVARSEL!

Lithiumbatteri - Eksplosionsfare ved fejlagtig håndtering.
Udskiftning må kun ske med batteri af samme fabrikat og type.
Levér det brugte batteri tilbage til leverandøren.

VARNING!

Explosionsfara vid felaktigt batteribyte.
Använd samma batterityp eller en ekvivalent typ som rekommenderas av apparattillverkaren.
Kassera använt batteri enligt fabrikantens instruktion.

ADVARSEL!

Lithiumbatteri - Eksplosjonsfare.
Ved utskifting benyttes kun batteri som anbefalt av apparatfabrikanten.
Brukt batteri returneres apparatleverandøren.

VAROITUS!

Paristo voi räjähtää, jos se on virheellisesti asennettu.
Vaihda paristo ainoastaan laitvalmistajan suosittelemaan tyyppiin. Hävitä käytetty paristo valmistajan ohjeiden mukaisesti.

For Germany

Bescheinigung des Herstellers/Importeurs

Hiermit wird bescheinigt, daß der/die/das
ROLAND EXPANDABLE SYNTHESIZER JV-90

(Gerät, Typ, Bezeichnung)

- in Übereinstimmung mit den Bestimmungen der BMPT-AmtsblVfg 243/1991 funk-entstört ist. Der vorschriftsmäßige Betrieb mancher Geräte (z. B. Meßsender) kann allerdings gewissen Einschränkungen unterliegen. Beachten Sie deshalb die Hinweise in der Bedienungsanleitung.

Dem Zentralamt für Zulassungen im Fernmeldewesen wurde das Inverkehrbringen dieses Gerätes angezeigt und die Berechtigung zur Überprüfung der Serie auf die Einhaltung der Bestimmungen eingeräumt.

Roland Corporation

4-16 Dojimahama 1-Chome Kita-ku Osaka 530 Japan

(Name und Anschrift des Herstellers/Importeurs)

For the USA

FEDERAL COMMUNICATIONS COMMISSION RADIO FREQUENCY INTERFERENCE STATEMENT

This equipment has been tested and found to comply with the limits for a Class B digital device, pursuant to Part 15 of the FCC Rules. These limits are designed to provide reasonable protection against harmful interference in a residential installation. This equipment generates, uses, and can radiate radio frequency energy and, if not installed and used in accordance with the instructions, may cause harmful interference to radio communications. However, there is no guarantee that interference will not occur in a particular installation. If this equipment does cause harmful interference to radio or television reception, which can be determined by turning the equipment off and on, the user is encouraged to try to correct the interference by one or more of the following measures:

- Reorient or relocate the receiving antenna.
- Increase the separation between the equipment and receiver.
- Connect the equipment into an outlet on a circuit different from that to which the receiver is connected.
- Consult the dealer or an experienced radio/TV technician for help.

Unauthorized changes or modification to this system can void the users authority to operate this equipment.
This equipment requires shielded interface cables in order to meet FCC class B Limit.

For Canada

CLASS B

NOTICE

This digital apparatus does not exceed the Class B limits for radio noise emissions set out in the Radio Interference Regulations of the Canadian Department of Communications.

CLASSE B

AVIS

Cet appareil numérique ne dépasse pas les limites de la classe B au niveau des émissions de bruits radioélectriques fixés dans le Règlement des signaux parasites par le ministère canadien des Communications.

 Roland®

10954

UPC 10954



10954