



Roland

HP 737 Roland Digital Piano

HP 237 Re/PE/Le Roland Digital Piano

Owner's Manual

Roland Digital Pianos

 CAUTION RISK OF ELECTRIC SHOCK DO NOT OPEN	
ATTENTION: RISQUE DE CHOC ELECTRIQUE NE PAS OUVRIR	
CAUTION: TO REDUCE THE RISK OF ELECTRIC SHOCK, DO NOT REMOVE COVER (OR BACK). NO USER-SERVICEABLE PARTS INSIDE. REFER SERVICING TO QUALIFIED SERVICE PERSONNEL.	



The lightning flash with arrowhead symbol, within an equilateral triangle, is intended to alert the user to the presence of uninsulated "dangerous voltage" within the product's enclosure that may be of sufficient magnitude to constitute a risk of electric shock to persons.



The exclamation point within an equilateral triangle is intended to alert the user to the presence of important operating and maintenance (servicing) instructions in the literature accompanying the product.

INSTRUCTIONS PERTAINING TO A RISK OF FIRE, ELECTRIC SHOCK, OR INJURY TO PERSONS.

IMPORTANT SAFETY INSTRUCTIONS

SAVE THESE INSTRUCTIONS

WARNING - When using electric products, basic precautions should always be followed, including the following:

1. Read all the instructions before using the product.
2. Do not use this product near water — for example, near a bathtub, washbowl, kitchen sink, in a wet basement, or near a swimming pool, or the like.
3. This product should be used only with a cart or stand that is recommended by the manufacturer.
4. This product, either alone or in combination with an amplifier and headphones or speakers, may be capable of producing sound levels that could cause permanent hearing loss. Do not operate for a long period of time at a high volume level or at a level that is uncomfortable. If you experience any hearing loss or ringing in the ears, you should consult an audiologist.
5. The product should be located so that its location or position does not interfere with its proper ventilation.
6. The product should be located away from heat sources such as radiators, heat registers, or other products that produce heat.
7. The product should be connected to a power supply only of the type described in the operating instructions or as marked on the product.
8. The power-supply cord of the product should be unplugged from the outlet when left unused for a long period of time.
9. Care should be taken so that objects do not fall and liquids are not spilled into the enclosure through openings.
10. The product should be serviced by qualified service personnel when:
 - A. The power-supply cord or the plug has been damaged; or
 - B. Objects have fallen, or liquid has been spilled onto the product; or
 - C. The product has been exposed to rain; or
 - D. The product does not appear to operate normally or exhibits a marked change in performance; or
 - E. The product has been dropped, or the enclosure damaged.
11. Do not attempt to service the product beyond that described in the user-maintenance instructions. All other servicing should be referred to qualified service personnel.

For the USA

This product may be equipped with a polarized line plug (one blade wider than the other) . This is a safety feature. If you are unable to insert the plug into the outlet, contact an electrician to replace your obsolete outlet. Do not defeat the safety purpose of the plug.

For Canada

For Polarized Line Plug

CAUTION: TO PREVENT ELECTRIC SHOCK, MATCH WIDE BLADE OF PLUG TO WIDE SLOT, FULLY INSERT.

ATTENTION: POUR ÉVITER LES CHOCs ÉLECTRIQUES, INTRODUIRE LA LAME LA PLUS LARGE DE LA FICHE DANS LA BORNE CORRESPONDANTE DE LA PRISE ET POUSSER JUSQU' AU FOND.

For the U.K.

IMPORTANT: THE WIRES IN THIS MAINS LEAD ARE COLOURED IN ACCORDANCE WITH THE FOLLOWING CODE.

BLUE: NEUTRAL
 BROWN: LIVE

As the colours of the wires in the mains lead of this apparatus may not correspond with the coloured markings identifying the terminals in your plug, proceed as follows:

The wire which is coloured BLUE must be connected to the terminal which is marked with the letter N or coloured BLACK.

The wire which is coloured BROWN must be connected to the terminal which is marked with the letter L or coloured RED.

Owner's Manual

Using the unit safely	2
Important notes	4
Main features of the HP Piano.....	5
Button descriptions.....	6
Getting started.....	8
Connecting the power cord.....	8
Opening and closing the lid.....	8
About the pedals.....	8
Turning the power on and off.....	9
Adjusting the volume.....	9
Setting up the music stand.....	10
Connecting headphones.....	11
Listening to the demo songs	12
Playing/stopping the demo songs.....	12
Selecting a song for playback.....	13
Playing the keyboard	14
Playing with various sounds.....	14
Layering two instrument sounds – Dual mode.....	14
Two different sounds for right and left hands –Split function.....	15
Reverb effect.....	16
Chorus effect.....	17
Using the metronome.....	18
Recording your performance	20
Recording.....	20
Listening to the recorded performance.....	22
Deleting recorded songs.....	22
Convenient functions	23
Changing keyboard's touch sensitivity.....	23
Playing in other keys – Key Transpose.....	23
Adjusting the pitch of the sound – Master Tuning.....	24
Changing the volume balance in Dual mode.....	25
Changing the depth of the Reverb.....	25
Changing the depth of the Chorus.....	25
Changing the damper pedal's resonance.....	26
Using classical tunings.....	26
Changing tuning curves.....	27
Disabling the buttons – Panel Lock.....	28
Connecting to MIDI devices	29
About the MIDI connectors.....	29
Making the connections.....	29
Tips for connecting an external MIDI Device.....	30
Switching Local on/off.....	30
Setting the MIDI channel.....	31
Selecting sounds via MIDI –Program Change.....	31
Turning transmission and reception of Control Changes on/off.....	32
Transmitting Recorder data from MIDI Out.....	33
Connecting audio equipment	34
Troubleshooting	35
Functions assigned to the keyboard	36
Specifications	37
List of demo songs	229
MIDI Implementation Chart.....	230

Before using this instrument, carefully read the sections entitled: "Important Safety Instructions" (p. i), "Using the unit safely" (p. 2), and "Important notes" (p. 4). These sections provide important information concerning the proper operation of the unit. Additionally, in order to feel assured that you have gained a good grasp of every feature provided by your new unit, Owner's manual should be read in its entirety. The manual should be saved and kept on hand as a convenient reference.

USING THE UNIT SAFELY

INSTRUCTIONS FOR THE PREVENTION OF FIRE, ELECTRIC SHOCK, OR INJURY TO PERSONS

About ⚠ WARNING and ⚠ CAUTION Notices

⚠ WARNING	Used for instructions intended to alert the user to the risk of death or severe injury should the unit be used improperly.
⚠ CAUTION	Used for instructions intended to alert the user to the risk of injury or material damage should the unit be used improperly. * Material damage refers to damage or other adverse effects caused with respect to the home and all its furnishings, as well to domestic animals or pets.

About the Symbols

	The ⚠ symbol alerts the user to important instructions or warnings. The specific meaning of the symbol is determined by the design contained within the triangle. In the case of the symbol at left, it is used for general cautions, warnings, or alerts to danger.
	The ⓧ symbol alerts the user to items that must never be carried out (are forbidden). The specific thing that must not be done is indicated by the design contained within the circle. In the case of the symbol at left, it means that the unit must never be disassembled.
	The ⓧ symbol alerts the user to things that must be carried out. The specific thing that must be done is indicated by the design contained within the circle. In the case of the symbol at left, it means that the power-cord plug must be unplugged from the outlet.

ALWAYS OBSERVE THE FOLLOWING

⚠ WARNING

- Before using this unit, make sure to read the instructions below, and the Owner's Manual.
- Do not open or perform any internal modifications on the unit.
- Do not attempt to repair the unit, or replace parts within it (except when this manual provides specific instructions directing you to do so). Refer all servicing to your retailer, the nearest Roland Service Center, or an authorized Roland distributor, as listed on the "Information" page.
- Never use or store the unit in places that are:
 - Subject to temperature extremes (e.g., direct sunlight in an enclosed vehicle, near a heating duct, on top of heat-generating equipment); or are
 - Damp (e.g., baths, washrooms, on wet floors); or are
 - Humid; or are
 - Exposed to rain; or are
 - Dusty; or are
 - Subject to high levels of vibration.
- Make sure you always have the unit placed so it is level and sure to remain stable. Never place it on stands that could wobble, or on inclined surfaces.
- The unit should be connected to a power supply only of the type described in the operating instructions, or as marked on the unit.
- Do not excessively twist or bend the power cord, nor place heavy objects on it. Doing so can damage the cord, producing severed elements and short circuits. Damaged cords are fire and shock hazards!

⚠ WARNING

- This unit, either alone or in combination with an amplifier and headphones or speakers, may be capable of producing sound levels that could cause permanent hearing loss. Do not operate for a long period of time at a high volume level, or at a level that is uncomfortable. If you experience any hearing loss or ringing in the ears, you should immediately stop using the unit, and consult an audiologist.
- Do not allow any objects (e.g., flammable material, coins, pins); or liquids of any kind (water, soft drinks, etc.) to penetrate the unit.
- In households with small children, an adult should provide supervision until the child is capable of following all the rules essential for the safe operation of the unit.
- Protect the unit from strong impact. (Do not drop it!)
- Do not force the unit's power-supply cord to share an outlet with an unreasonable number of other devices. Be especially careful when using extension cords—the total power used by all devices you have connected to the extension cord's outlet must never exceed the power rating (watts/amperes) for the extension cord. Excessive loads can cause the insulation on the cord to heat up and eventually melt through.
- Before using the unit in a foreign country, consult with your retailer, the nearest Roland Service Center, or an authorized Roland distributor, as listed on the "Information" page.

⚠ CAUTION

- The unit should be located so that its location or position does not interfere with its proper ventilation. 

- Always grasp the plug on the power-supply cord when plugging into, or unplugging from, an outlet or this unit. 

- Try to prevent cords and cables from becoming entangled. Also, all cords and cables should be placed so they are out of the reach of children. 

- Never climb on top of, nor place heavy objects on the unit. 

- Never handle the power cord or its plugs with wet hands when plugging into, or unplugging from, an outlet or this unit. 

- Before moving the instrument take note of the precautions listed below. At least two persons are required to safely lift and move the unit. It should be handled carefully, all the while keeping it level. Make sure to have a firm grip, to protect yourself from injury and the instrument from damage. 
 - Check to make sure the knob bolts securing the unit to the stand have not become loose. Fasten them again securely whenever you notice any loosening.
 - Disconnect the power cord.
 - Disconnect all cords coming from external devices.
 - Raise the adjusters on the stand (p. 9).
 - Close the lid.
 - Remove the music stand.

- Before cleaning the unit, turn off the power and unplug the power cord from the outlet (p. 8). 

- Whenever you suspect the possibility of lightning in your area, pull the plug on the power cord out of the outlet. 

- Be careful when opening/closing the lid so you do not get your fingers pinched (p. 8). Adult supervision is recommended whenever small children use the unit. 

- Should you remove the screws fastening the stand, make sure to put them in a safe place out of children's reach, so there is no chance of them being swallowed accidentally. 

Important notes

In addition to the items listed under "IMPORTANT SAFETY INSTRUCTIONS" and "USING THE UNIT SAFELY" on pages 2, 3 and 4, please read and observe the following:

Power supply

- Do not use this unit on the same power circuit with any device that will generate line noise (such as an electric motor or variable lighting system).
- Before connecting this unit to other devices, turn off the power to all units. This will help prevent malfunctions and/or damage to speakers or other devices.

Placement

- Using the unit near power amplifiers (or other equipment containing large power transformers) may induce hum. To alleviate the problem, change the orientation of this unit; or move it farther away from the source of interference.
- This device may interfere with radio and television reception. Do not use this device in the vicinity of such receivers.
- Do not expose the unit to direct sunlight, place it near devices that radiate heat, leave it inside an enclosed vehicle, or otherwise subject it to temperature extremes. Also, do not allow lighting devices that normally are used while their light source is very close to the unit (such as a piano light), or powerful spotlights to shine upon the same area of the unit for extended periods of time. Excessive heat can deform or discolor the unit.
- To avoid possible breakdown, do not use the unit in a wet area, such as an area exposed to rain or other moisture.
- Do not allow rubber, vinyl, or similar materials to remain on the piano for long periods of time. Such objects can discolor or otherwise harmfully affect the finish.
- Do not put anything that contains water (e.g., flower vases) on the piano. Also, avoid the use of insecticides, perfumes, alcohol, nail polish, spray cans, etc., near the unit. Swiftly wipe away any liquid that spills on the unit using a dry, soft cloth.
- Do not allow objects to remain on top of the keyboard. This can be the cause of malfunction, such as keys ceasing to produce sound.
- Do not paste stickers, decals, or the like to this instrument. Peeling such matter off the instrument may damage the exterior finish.

Maintenance

- To clean the unit, use a dry, soft cloth; or one that is slightly dampened. Try to wipe the entire surface using an equal amount of strength, moving the cloth along with the grain of the wood. Rubbing too hard in the same area can damage the finish.
- Never use benzine, thinners, alcohol or solvents of any kind, to avoid the possibility of discoloration and/or deformation.

Additional precautions

- Use a reasonable amount of care when using the unit's buttons, sliders, or other controls; and when using its jacks and connectors. Rough handling can lead to malfunctions.
- When connecting/disconnecting all cables, grasp the connector itself—never pull on the cable. This way you will avoid causing shorts, or damage to the cable's internal elements.
- A small amount of heat will radiate from the unit during normal operation.
- To avoid disturbing your neighbors, try to keep the unit's volume at reasonable levels. You may prefer to use headphones, so you do not need to be concerned about those around you (especially when it is late at night).
- When you need to transport the unit, pack it in shock-absorbent material. Transporting the unit without doing so can cause it to become scratched or damaged, and could lead to malfunction.
- Use a cable from Roland to make the connection. If using some other make of connection cable, please note the following precautions.
 - Some connection cables contain resistors. Do not use cables that incorporate resistors for connecting to this unit. The use of such cables can cause the sound level to be extremely low, or impossible to hear. For information on cable specifications, contact the manufacturer of the cable.

Main features of the HP Piano

Authentic piano performances

High-quality concert grand piano tones, combined with the Progressive Hammer Action keyboard, which provides more realistic piano touch let you enjoy truly authentic piano performances. The keyboard provides a heavier feel in the low end and a lighter feel in the upper notes.

- **Captures the brilliant resonance**

The sound of a grand piano has a more brilliant timbre than that of an upright piano. This is because the sound of a grand piano contains a greater amount of high-frequency components. The HP Piano's sounds faithfully reproduce this characteristic of the grand piano.

- **Extended high-frequency response**

One of the features of an acoustic piano is that for the approximately one and a half octaves at the top of the range, there is no damper to restrict the vibration of the strings. This allows the vibrations to continue whether or not the damper pedal is pressed. Since this also allows these strings to vibrate sympathetically with other strings, they can sometimes be heard when you play in the low and middle registers. The HP Piano faithfully simulates these characteristics of an acoustic piano.

Nine Tones for use in a wide variety of musical genres

The HP Piano features not only piano tones, but nine different internal tones that you can use in a variety of musical genres (8 tones + 1 additional tone in Split mode).

Three metronome sounds

The HP Piano provides a metronome that lets you use three different sounds. You can easily adjust the tempo and time signature.

Record your own performances

The HP Piano makes it easy to record your own performances.

Stylish look in different versions

The HP-237 family has been expanded to include a black polished ebony (HP-237PE) and a light oak (HP-237Le) version in addition to the original Simulated Rosewood cabinet (HP-237Re).

The HP-737, on the other hand, is Roland's new baby grand piano – an instrument whose looks already hint at the sonic excellence you will get.

Button descriptions

MEMO Button, switch and knob names are enclosed in square brackets [].

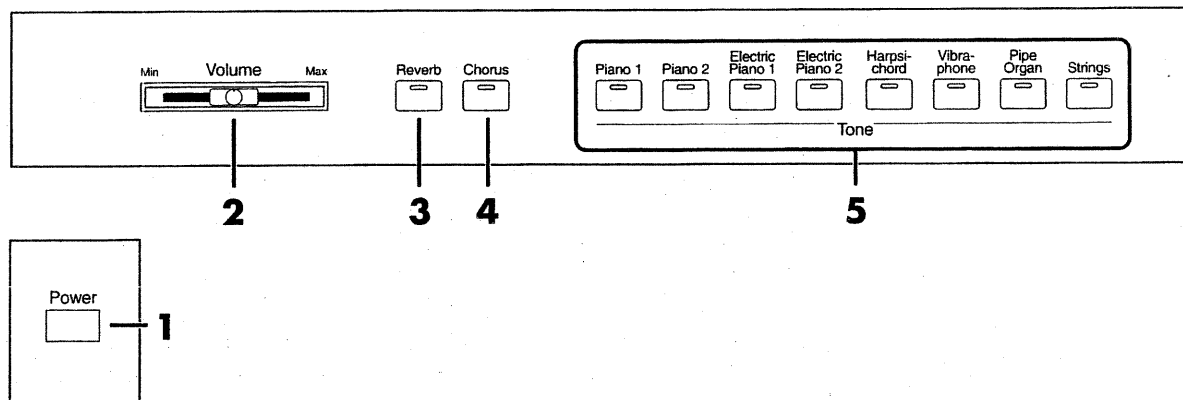

1 [Power] switch

Press this switch to power the HP Piano on and off (p. 9).

2 [Volume] slider

Adjusts the overall volume (p. 9).

3 [Reverb] button

Used to add reverberation to the sound (p. 16).

4 [Chorus] button

Adds the Chorus Effect to the sound (p. 17).

5 Tone selection buttons

The following eight buttons are collectively referred to as the "Tone buttons". These are used to select the tone to be played via the keyboard (p. 14).

[Piano 1] button

[Piano 2] button

[Electric Piano 1] button

[Electric Piano 2] button

[Harp-sichord] button

[Vibraphone] button

[Pipe Organ] button

[Strings] button

By holding down three of these buttons while pressing a specific key, you can make various settings on the HP Piano.

→ "Functions assigned to the keyboard" (p. 36)

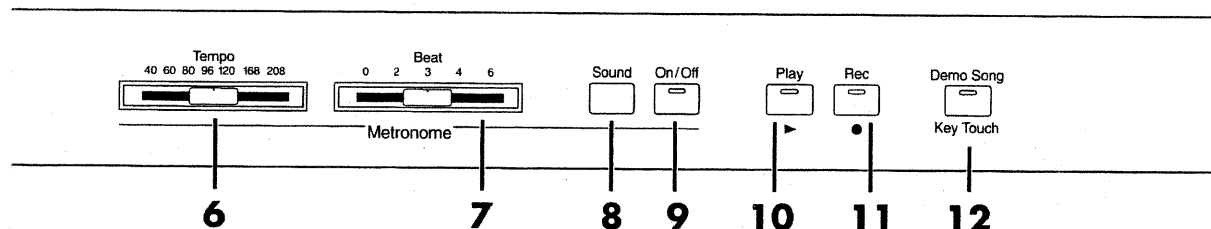

6 Metronome [Tempo] slider

This adjusts the tempo of the metronome (p. 19).

7 Metronome [Beat] slider

Used to select the time signature of the metronome (p. 19).

8 Metronome [Sound] button

This is used to change the metronome sound (p. 19).
This button is also used in setting the Split function (p. 15).

9 Metronome [On/Off] button

Activates the built-in metronome (p. 18).

10 [Play] button

This starts and stops the demo songs, or a recorded performance (p. 12, p. 22).
It also is used to start/stop recording (p. 20).

11 [Rec] button

Press this button to put the HP Piano in recording standby (p. 20).

12 [Demo Song/Key Touch] button

This plays the demo songs (p. 12).
By holding down this button while you press a specific key, you can change the touch sensitivity (p. 23) or make various settings on the HP Piano.
→ "Functions assigned to the keyboard" (p. 36)

Getting started

Connecting the power cord

NOTE

To prevent malfunction and/or damage to speakers or other devices, always turn down the volume, and turn off the power on all devices before making any connections.

1. Connect the supplied power cable to the AC Inlet on the rear panel of the HP Piano.
2. Connect the power cable to an AC outlet.

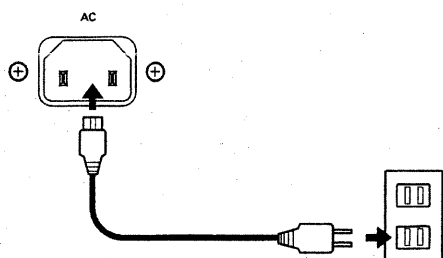

Opening and closing the lid

1. When opening the HP Piano's lid, grasp it with both hands and gently lift it upwards, then slide it towards the back of the piano.
2. When closing the lid, slowly pull it forward, then gently lower it into place.

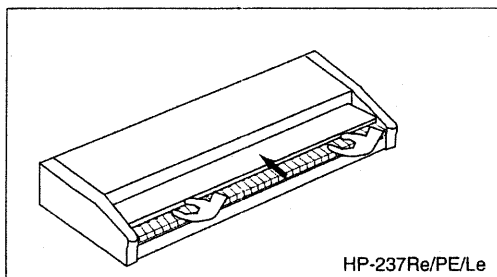

HP-237Re/PE/Le

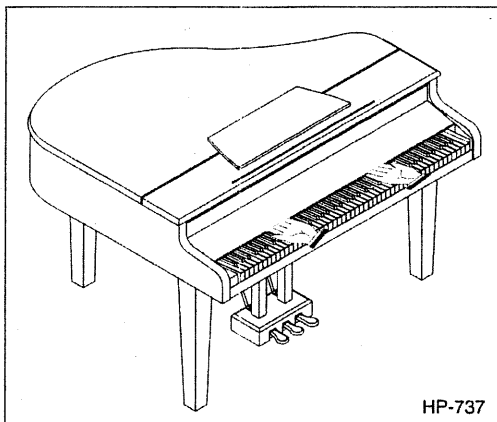

HP-737

Never insert your hands between the lid and the keyboard.

NOTE

Take care not to allow fingers to be caught or pinched when opening and closing the lid. Make sure an adult is on hand to provide assistance when young children are playing the HP Piano.

NOTE

For safety, transport the HP Piano only with the lid in the closed position.

About the pedals

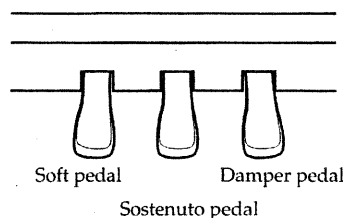

Soft pedal: Playing with the soft pedal depressed produces a rounder and more subdued sound compared to what you hear when you play with the equivalent strength while not pressing the pedal.

Sostenuto pedal: With the sostenuto pedal, only the sound played at the moment the pedal is pressed is sustained.

Damper pedal: Use this pedal when you want the sound to linger. On acoustic pianos, when the damper pedal is depressed, additional strings are released to resonate with the sound of the keys that have been played, adding richness and breadth to the sound. The damper function on the HP Piano recreates this resonance when depressed. This is called "Sympathetic Resonance".

MEMO

You can change the amount of resonance applied with the damper pedal. For more information and instructions, please refer to p. 26.

About the adjuster

After you have moved this piano, or when you feel it is unstable, lower the adjuster at the bottom of the pedal board as follows:

- Lower the adjuster so that it is firmly in contact with the floor. If there is a gap between the adjuster and the floor, the unit may malfunction when the pedal is pressed. In particular when the instrument is placed on a carpeted floor, you must lower the adjuster so that it presses strongly against the floor.

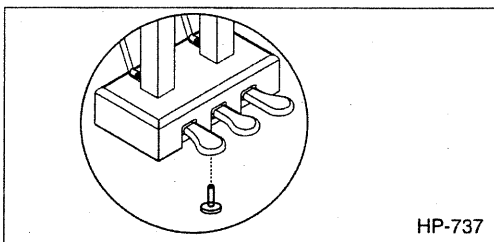
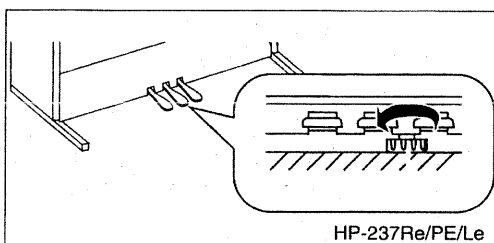

Turning the power on and off

NOTE

Once the connections have been completed, turn on power to your various devices in the order specified. By turning on devices in the wrong order, you risk causing malfunction and/or damage to speakers and other devices.

■ Turning on the power

1. Before you switch on the power, turn the volume all the way down by using the [Volume] slider.

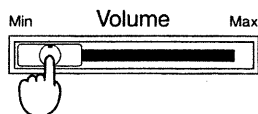

2. Press the [Power] switch, to turn on the power.

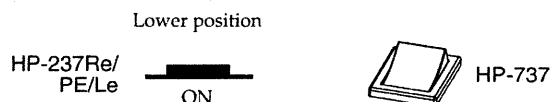

After a few seconds, the HP Piano will produce sound when played. Adjust the volume appropriately.

NOTE

This unit is equipped with a protection circuit. A brief interval (a few seconds) after power up is required before the unit will operate normally.

■ Turning off the power

1. Before switching the power off, turn the volume all the way down by using the [Volume] slider.

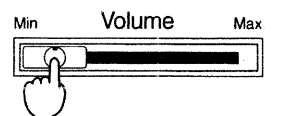

2. Press the [Power] switch, to turn off the power.

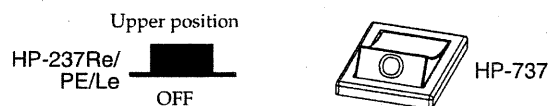

The power is turned off.

Adjusting the volume

Use the [Volume] slider to adjust the overall volume.

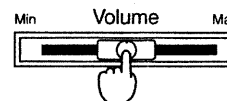

Setting up the music stand

Set up the music stand as shown in the figure below.

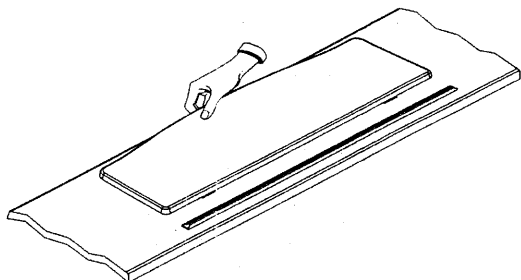

Fold the three supporting feet at the back of the stand and check whether the stand is held in place.

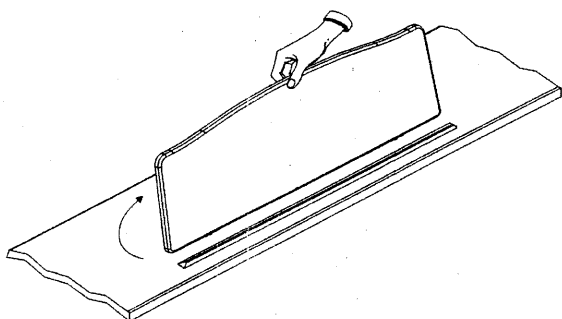

NOTE

Before moving the HP Piano, be sure to lower the music stand as a safety precaution.

Opening and closing the lid (HP-737)

The HP-737's lid can be raised and closed like on an acoustic grand piano. Though this is mainly intended to help you obtain a better spread of the sound, it also changes the HP-737's tone color.

There are two positions for the lid: half open and fully open.

- 1. Carefully raise the lid with one hand, taking care to get a secure grip.**
- 2. Fold out the supporting leg.**
Select the small end for the "half raised" position, and the longer one for the "fully raised" position.
- 3. Lower the lid until you are sure it is supported by the leg.**
Here's what your HP-737 should look like once the lid is in place:

Fully raised

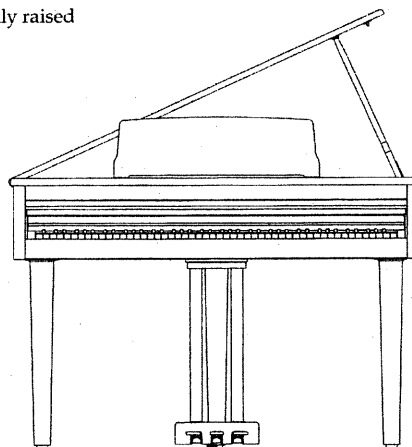

Half raised

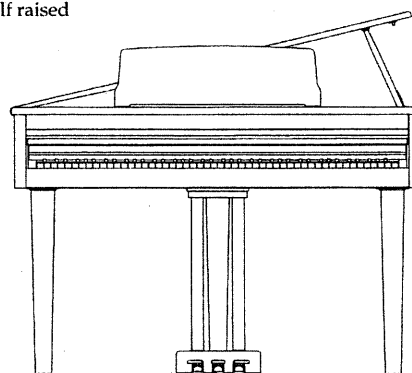

NOTE

If you are not sure how to raise the lid, ask your Roland dealer to show you how it's done.

Connecting headphones

The HP Piano features two headphone jacks. This allows two people to listen through headphones simultaneously, making it very useful for lessons and when performing piano pieces for four hands. Additionally, this allows you to play without having to worry about bothering others around you, even at night.

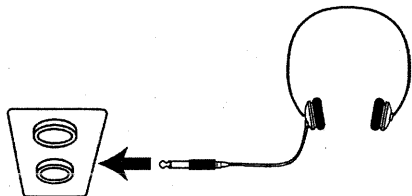

1. Turn the volume all the way down by using the [Volume] slider.
2. Plug the headphones into the Phones jack on the lower-left panel of the HP Piano.
This switches off the HP Piano speakers. Sound will be heard only through the headphones.
3. Use the [Volume] slider to adjust the volume of the headphones.

NOTE

Please use stereo headphones.

● Precautions to take when using headphones

- To avoid damaging or severing the headphone cord, be sure to handle the headphones by holding the phones themselves, and grasping the plug and not the cord when pulling the headphone plug.
- Connecting headphones when the volume is turned up may result in damage to the headphones. Connect the headphones only after turning the volume down completely.
- Listening at excessively high volume levels will not only damage the headphones, but may also cause hearing loss. Listen at appropriate levels.

Listening to the demo songs

Your HP Piano contains thirty-two piano songs.

Playing/stopping the demo songs

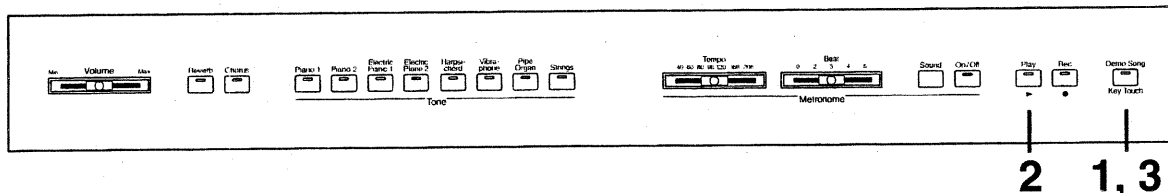

1. Press the [Demo Song/Key Touch] button, and confirm that the indicator has lit.

The [Play] button's indicator starts blinking.

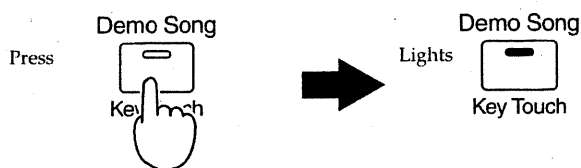

2. Press the [Play] button. The indicator now lights.

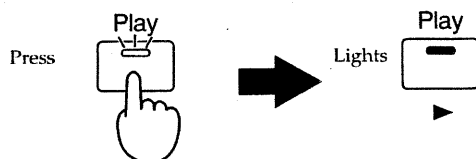

The demo songs will play back in succession, starting with the first song. When the last song has been played, playback will return to the first song and begin again.

3. To stop the demo song playback, press the [Demo Song/Key Touch] button to make the indicator go out.

Demo song playback will stop.

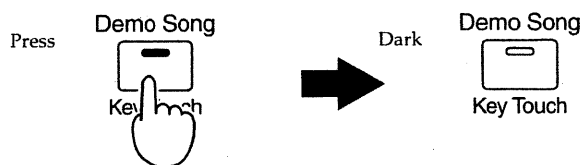

You can also stop demo song playback by pressing the [Play] button or [Rec] button. In this case, the [Demo Song/Key Touch] button indicator will not be extinguished. When you press the [Play] button next the demo song will resume playing from the beginning of the song where playback was halted.



It is not possible to change the tempo of a demo song.



If you press the [Demo Song/Key Touch] button while the metronome is sounding (p. 18), the metronome will stop. It is not possible to sound the metronome while a demo song is playing.

Selecting a song for playback

Here's how you can select and play the desired demo song.

Hold down the [Demo Song/Key Touch] button and press the Tone button that corresponds to the demo song you wish to hear.

Four demo songs are assigned to each one of the Tone buttons.

While holding down the [Demo Song/Key Touch] button, you may have to press the relevant button several times to cycle through the four song choices available for that button.

For example, to play back from song "1-3," hold down the [Demo Song/Key Touch] button and press the [Piano 1] button three times.

If you are already playing back song "1-1," hold down the [Demo Song/Key Touch] button and press the [Piano 1] button twice to play Song "1-3."

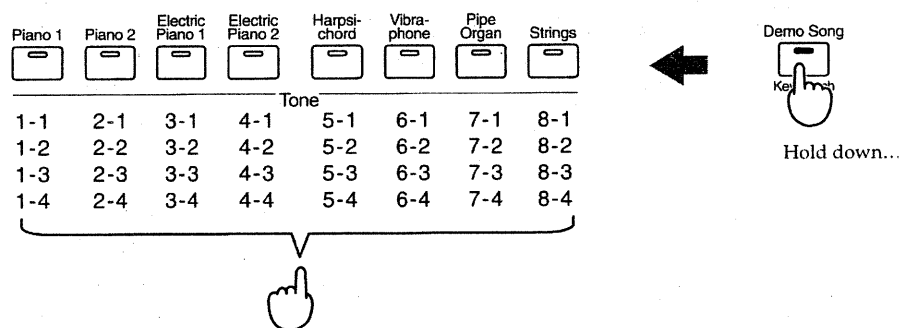

... and press the button corresponding to the song number.

The indicators of the [Demo Song/Key Touch] button and the [Play] button will light. The demo songs will play back consecutively, starting with the song you selected. When the last song has been played, playback will return to the first song and resume.

Subsequent demo songs are automatically played one after another until you stop playback. See p. 229 for a list of the available demo songs.

Profiles of composers

John Maul

John Maul is a musician, composer and arranger having graduated from the Royal Academy of Music in London. John's work encompasses studio recordings and live performances including work with top UK Jazz artists. His writing credits include commercial music for BBC radio and television, as well as scoring jazz and classical works. Having been a product specialist for Roland U.K., John is now actively involved in music software composing/programming for both Roland Japan and various music publishers. Quite recently his "Musical Picture Book," a volume of original piano music encompassing all standards of musical ability, which included the piano and orchestral accompaniment data in SMF format, was published and printed.

- * All rights reserved. Unauthorized use of this material for purposes other than private, personal enjoyment is a violation of applicable laws.
- * No data for the music that is played will be output from MIDI OUT.

Naoki Nishi

Born in 1958 in Hiroshima, Japan. Began working professionally at the age of 21. Has so far released 9 albums on which he is featured. He has also taken part in numerous other albums. His broad range of activities have included appearances at a number of jazz festivals in Japan and other parts of the world. In addition to his duties as an instructor at the Tokyo Conservatoire Shoubi, he has provided his services as a demonstrator for Roland since 1990. He is considered to be one of Japan's finest jazz pianist.

Playing the keyboard

Playing with various sounds

The HP Piano provides eight different sounds including piano. The HP Piano's sounds are called "Tones." Use the eight Tone buttons to select tones. When the HP Piano is turned on, the tone is reset to "Piano 1".

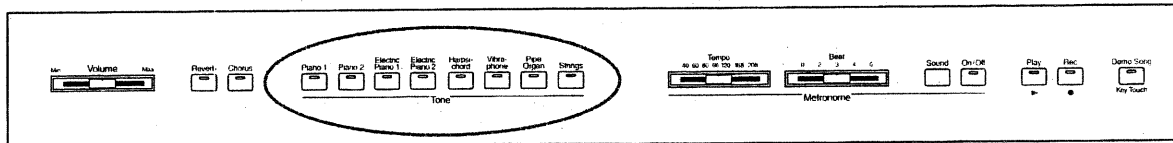

Press any Tone button and confirm that its indicator is lit.

When you play the keyboard, the selected tone is played.

Tone Name	Description
Piano 1	Full-sized concert grand piano Rich stereo sound, providing 32 polyphonic notes.
Piano 2	Full-sized concert grand piano 64 polyphonic notes
Electric Piano 1	Sound of a Rhodes piano
Electric Piano 2	A synthesizer's electric piano
Harpsichord	Delicate and elegant harpsichord sound
Vibraphone	The sound of a resonant vibraphone
Pipe Organ	A stately pipe organ sound
Strings	An ensemble of string instruments

Layering two instrument sounds – Dual mode

Playing with two different tones on the keyboard simultaneously is called "Dual Play."

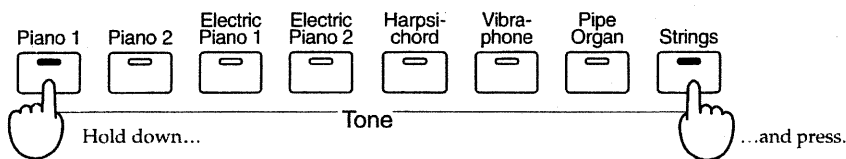

1. While holding down the [Piano 1] button, press the [Strings] button.

The indicators on the two Tone buttons you pressed will light, and both of the Tones will be heard when you play the keyboard.

In this way, you can hold down one Tone button and press another Tone button to layer two sounds for playing together.

2. To leave Dual mode, press any Tone button.

When you play the keyboard, only the sound of the button you pressed will be heard.



You can adjust the volume balance between the two selected tones in Dual Play. Please refer to "Changing the volume balance in Dual mode" (p. 25).

Two different sounds for right and left hands – Split function

The HP Piano allows you to divide the keyboard into two sections, upper and lower, and to play two different Tones. Dividing the keyboard is called “Split” and the key where the keyboard is split is called the “Split Point”.

The Split Point is at “F # 3” when the power is turned on.

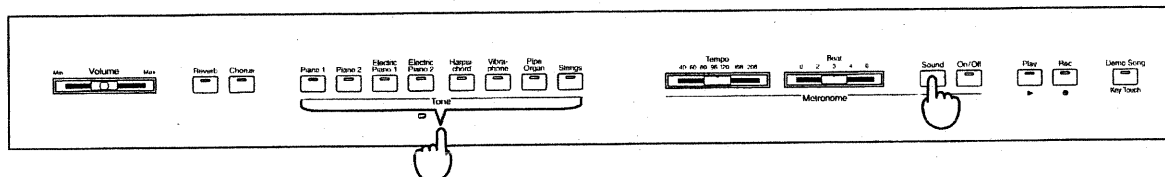

1. Hold down the Tone button for the sound that you want to include in the split, and press the Metronome [Sound] button.

The indicator on the Tone button you have pressed will flash. Play the keyboard and check whether two different sounds can be played in the upper and lower sections.

The Tone buttons provide the following Split combinations:

Tone button	Lower Tone / Upper Tone
Piano 1	Acoustic Bass / Piano 1
Piano 2	Acoustic Bass / Piano 2
Electric Piano 1	Acoustic Bass / Electric Piano 1
Electric Piano 2	Acoustic Bass / Electric Piano 2
Harpsichord	Strings / Harpsichord
Vibraphone	Acoustic Bass / Vibraphone
Pipe Organ	Pipe Organ / Harpsichord
Strings	Strings / Piano 1

* Chorus (p. 17) cannot be applied to the “Acoustic Bass” tone.

* The pedal will have no effect on what is played in the lower section of the keyboard.

2. To cancel Split, press a Tone button whose indicator is dark.

The tone whose indicator lights is assigned to the entire keyboard.

Changing the split point

When you are using the Split function, you can change the location at which the keyboard is split (the Split Point).

Hold down the Tone button whose indicator is blinking, and press the note that you wish to use as the new Split Point.

The split point can be set between the B1 and the B6. The key that serves as the split point is part of the lower section.

The split point you set will be retained until the piano is switched off.

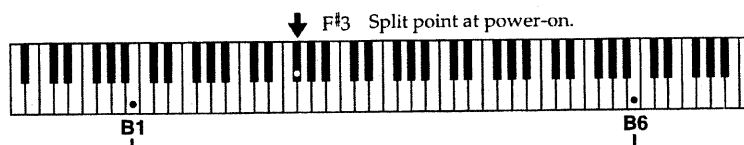

Reverb effect

The HP Piano allows you to add reverberation to what you play on the keyboard. With the Reverb effect, you can give the impression that you are performing in a concert hall or similar space.

The settings of the Reverb effect cannot be memorized independently for each sound. When the power is turned on, the Reverb effect will be switched off.

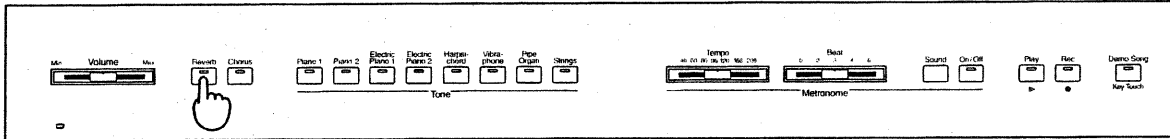

1. Press the [Reverb] button to turn on the indicator.

The Reverb Effect will be applied to all notes you play.

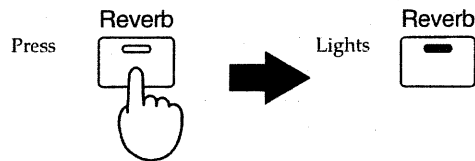

2. To cancel the Reverb effect, press the [Reverb] button once again to make the indicator go dark.

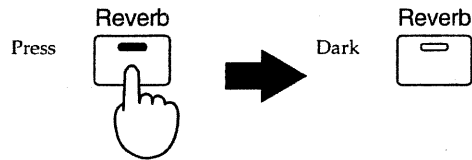

The amount of Reverb can be changed. Please refer to "Changing the depth of the Reverb" (p. 25).

Chorus effect

The HP Piano allows you to add Chorus to what you play on the keyboard. By doing so, you can give the sound a greater dimension, with more fatness and breadth.

The settings of the Chorus effect are memorized independently for each sound.

When the power is turned on, the Chorus effect will be applied to the "Electric Piano 1", "Electric Piano 2" and "Vibraphone" sounds. It will be turned off whenever you select another sound.

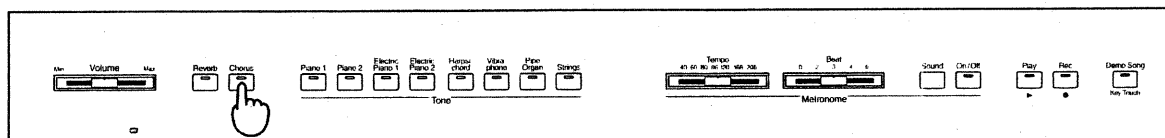

1. Press the [Chorus] button to turn on the indicator.

The Chorus effect will be applied to the currently selected sound.

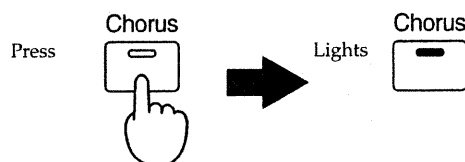

When you select a sound for which the Chorus effect has not been turned on, the [Chorus] indicator will go dark.

2. To switch off the Chorus effect, press the [Chorus] button once again to make the indicator go dark.



In Dual (p. 14) and Split modes (p. 15), the [Chorus] button applies to both sounds. (However, when Split is being used, the Chorus effect will not be applied to the Acoustic Bass.)

After Dual or Split is cancelled, the HP Piano reverts to the Chorus effect setting that a particular sound normally uses.



The on/off status of the [Chorus] button is not remembered when Dual or Split are used.



The amount of Chorus can be changed. Please refer to "Changing the depth of the Chorus" (p. 25).

Using the metronome

You can start or stop the metronome with a single button. In addition to adjusting the tempo and time signature, you can also change the sound and volume of the metronome.

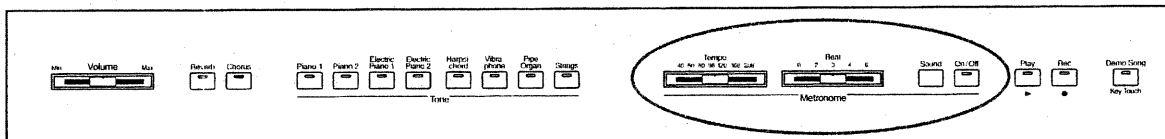

1. Press the Metronome [On/Off] button to start the metronome.

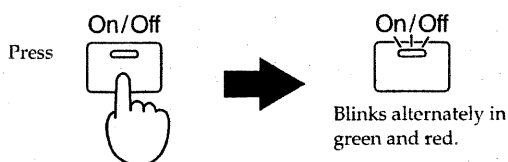

The Metronome [On/Off] indicator will blink in red and green in time with the currently selected tempo and time signature: red on the downbeats, and in green on the upbeats. If the Metronome [Beat] slider is in the "0" position, the indicator will blink in green.

2. Press the Metronome [On/Off] button once again to stop the metronome.

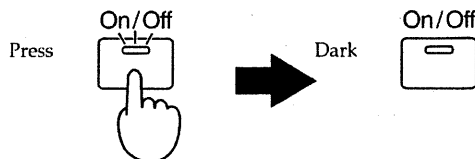

■ Adjusting the metronome volume

The metronome volume can be adjusted in 8 levels. It is set to "4" when the HP Piano is turned on.

While holding down the Metronome [On/Off] button, press any Tone button to change the metronome volume.

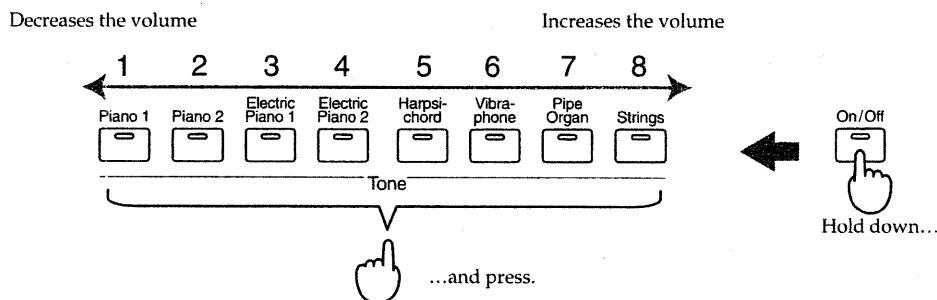

■ Checking the metronome volume

Press and hold the Metronome [On/Off] button.

The Tone button indicators will blink to indicate the current volume.

■ Changing the metronome tempo

The metronome tempo is adjusted by the Metronome [Tempo] slider.

You can select a tempo in the range of 40~208.

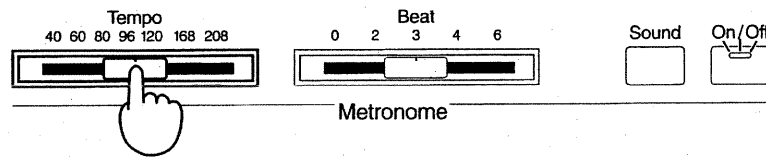

■ Changing the time signature of the metronome

Use the Metronome [Beat] slider to select the time signature of the metronome.

You can select from the following five types: 0 (only upbeat sounds), 2 (2-beat), 3 (3-beat), 4 (4-beat), 6 (6-beat).

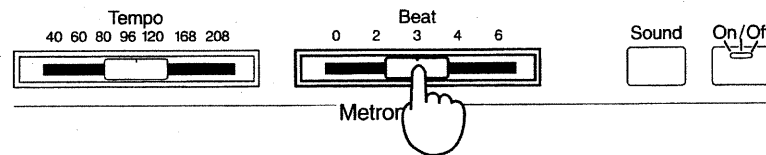

■ Changing the metronome sound

You can select from three types of metronome sound: "normal metronome sound," "electronic metronome sound," and "dog and cat sounds."

"Normal" is the power-on default for the metronome sound.

1. Press the Metronome [On/Off] button to start the metronome.
2. Press the Metronome [Sound] button.

Each time you press the Metronome [Sound] button, the metronome sound will change to the next choice available, either "normal," "electronic," or "dog and cat sounds."

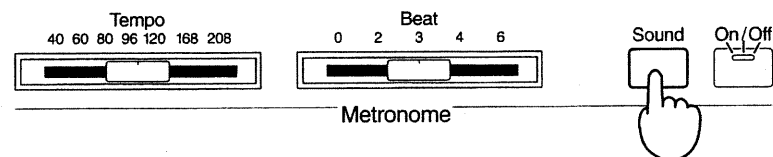

Recording your performance

You can record what you play on your piano.

- NOTE** Only one song can be recorded on the HP Piano. If a previously recorded performance exists, it will be erased the moment you begin recording another performance.
- NOTE** The performance data that you recorded will disappear when the power of the HP Piano is turned off.
- NOTE** After approximately 5,000 notes have been recorded, the [Play] button's and [Rec] button's indicators will go out, and recording will end automatically.

Recording

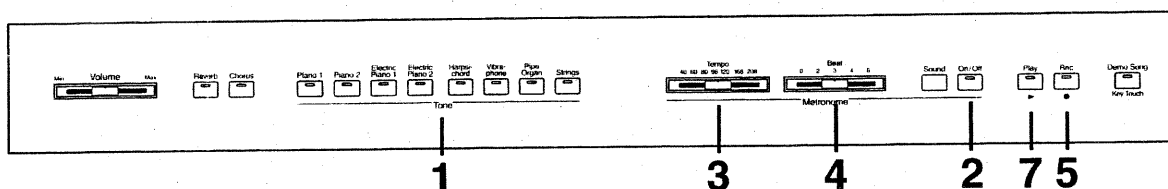

1. Use the Tone buttons to select the sound you want to use for your recording.

You can change the tones during the recording of the song.

2. Press the Metronome [On/Off] button to turn on the indicator.

The metronome will sound.

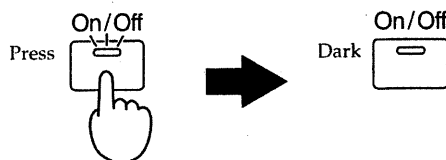

While listening to the metronome, select the tempo and time of the song that you wish to record.

3. Use the Metronome [Tempo] slider to select the basic tempo for the song.

Moving the Metronome [Tempo] slider after recording has begun will not change the tempo.

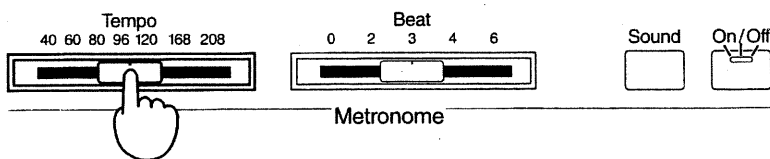

4. Use the Metronome [Beat] slider to select the time for the song.

The time of the song cannot be changed during or after recording.

5. Press the [Rec] button to turn on the indicator.

The HP Piano is put in record standby mode. The [Play] indicator flashes.

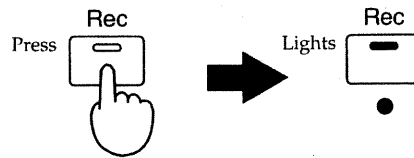

To cancel the recording at this stage, press the [Rec] button once more to make the indicator dark. To stop the metronome, press the Metronome [On/Off] button to make the indicator go dark. In the beginning, it is probably a good idea to listen to the metronome as you record. The sound of the metronome is not recorded.

6. Recording will begin when you play a note on the keyboard.

The [Play] indicator will change from blinking to lit.

Instead of playing the keyboard, you can also begin recording by pressing the [Play] button to make the indicator light. In this case, you will hear a two-measure count-in before recording begins.

Listen to the metronome, and play along with the tempo.

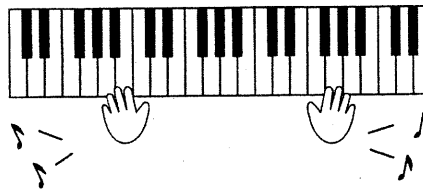

7. When you are finished recording, press the [Play] button to make the indicator go dark.

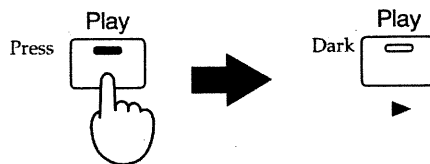

You can use a MIDI sequencer to save the recorded performance. Please refer to "Transmitting Recorder data from MIDI Out" (p. 33).

Listening to the recorded performance

Listen to the performance you recorded.

1. Press the [Play] button to make the indicator light.

The performance you recorded will play back. When the recorded performance ends, the [Play] button indicator will go dark, and playback will stop.

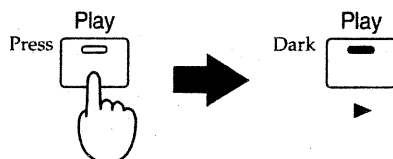

2. If you wish to stop playback during the performance, press the [Play] button to make the indicator go dark.

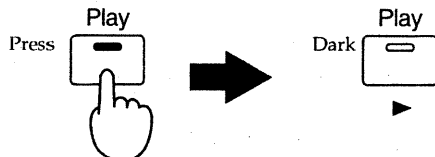

If the metronome is sounding while the performance plays back, playback will begin after a two-measure count-in.



If you have recorded in Dual mode (p. 14), you can play back the performance with a different volume balance between the two layered tones. Please refer to "Changing the volume balance in Dual mode" (p. 25).

Deleting recorded songs

You can delete a recorded song.

Hold down the [Play] button and press the [Rec] button.

This deletes the recorded song.

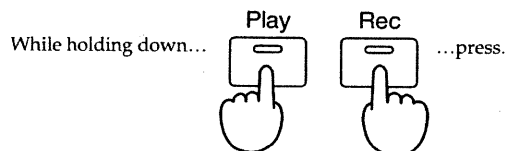

Convenient functions

Changing keyboard's touch sensitivity

You can select from three touch sensitivity levels. When the power is turned on, the response is set to "Medium."

While holding down the [Demo Song/Key Touch] button, press the corresponding note (A3~B3).

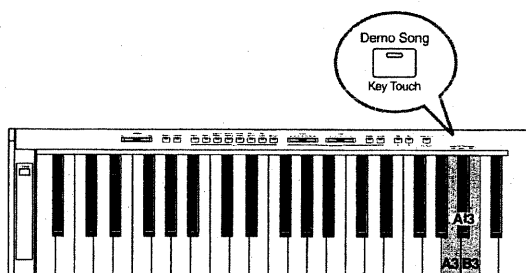

Key	Type	Descriptions
A3	Light	With this setting, fortissimo can be produced using much less force than normal, thus making the keys seem lighter. This setting makes it easy to play, even for children.
A#3	Medium	Normal setting, providing the most natural touch, closest to that of an acoustic piano.
B3	Heavy	With this setting, to play fortissimo the keys must be pressed much more strongly than normally, as if the keys had become heavier. Adds even more emotion when you play with lots of dynamics.

Playing in other keys – Key Transpose

You can play in a different key without pressing other keys. This function is called "Key Transpose."

When you are accompanying a singer, you can use Key Transpose to match the singer's vocal pitch, allowing you to transpose easily while using the same printed music (keyboard fingering).

Key transpositions remain in effect until the power is turned off.

1. While holding down the [Demo Song/Key Touch] button, press the tonic (root) of the key to which you want to transpose.

Use the C2~B2 notes to select the tonic (root).

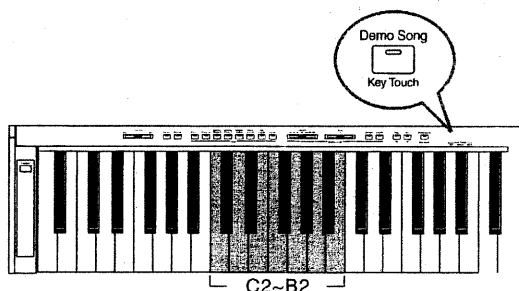

2. To return to the normal pitch, while holding down the [Demo Song/Key Touch] button, press the C2 key.

<Ex.>

For example if you want the E pitch to sound when you play the C key, you would hold down the [Demo Song/Key Touch] button and press the E2 key.

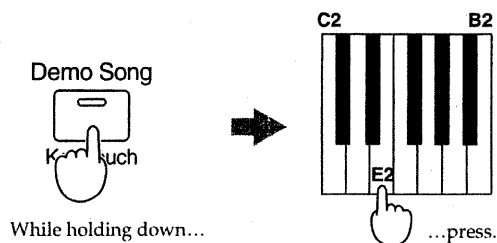

NOTE

The transposition setting is effective only for the notes you play on the HP Piano's keyboard. It does not apply to note messages received via MIDI.

Adjusting the pitch of the sound – Master Tuning

When playing in ensemble with other instruments, you can adjust the HP Piano's reference pitch to that of another instrument.

Middle A is generally used as the standard reference pitch for tuning instruments.

When playing in ensemble with other instruments, set each instrument to the same reference pitch to ensure that you will be in tune with each other. This tuning of all the instruments to a reference pitch is called "Master Tuning."

The reference pitch can be set to any value from 415.3 Hz–466.2 Hz. "440 Hz" is the power-on default for the reference pitch.

Use the C4–D#4 notes to adjust the pitch.

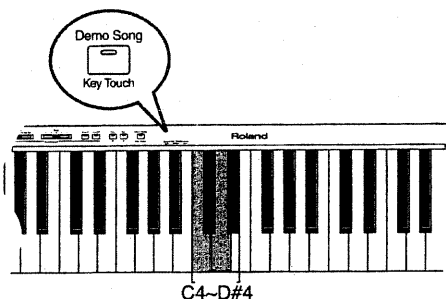

■ Lowering/raising the reference pitch

While holding down the [Demo Song/Key Touch] button, press the "C4" note to lower the reference pitch, or the "D4" note to raise it.

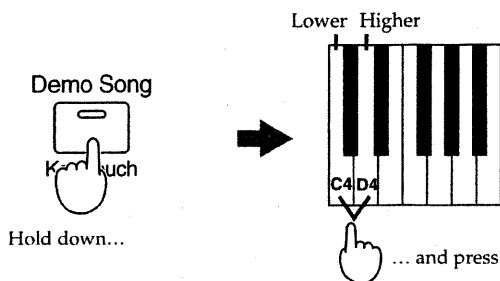

Each time you press the "C4" key, the pitch will fall by 0.1 Hz. If you continue holding the key, the pitch will continue falling.

Each time you press the "D4" key, the pitch will rise by 0.1 Hz. If you continue holding the key, the pitch will continue rising.

■ Setting the reference pitch to 440 Hz

While holding down the [Demo Song/Key Touch] button, press the "C#4" key on the keyboard.

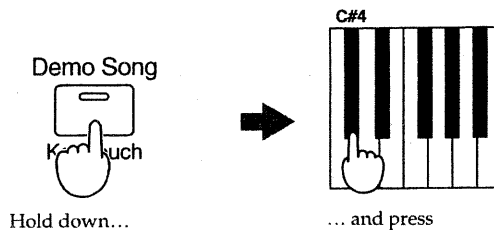

The reference pitch will be set to 440 Hz. This is the most commonly used setting. The A4 (Middle A) key will sound at 440 Hz.

■ Setting the reference pitch to 442 Hz

While holding down the [Demo Song/Key Touch] button, press the "D#4" key on the keyboard.

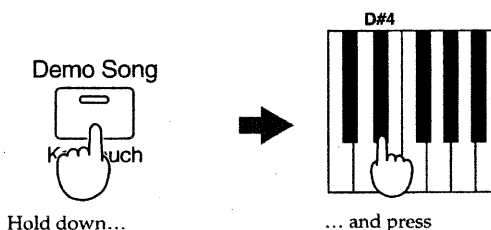

The standard pitch will be set to 442 Hz. This setting is often used for concert pianos. The A4 (Middle A) key will sound at 442 Hz.

Sounding a reference tone while you adjust the pitch

Holding down the [Demo Song/Key Touch] button, press the [Sound] button, and while continuing to hold down these two buttons, press a "tuning key".

You can hear a reference tone (Middle A) as you adjust the pitch.

Changing the volume balance in Dual mode

You can change the volume balance between the two layered sounds in Dual mode (p. 14).
When the Keyboard is turned on, the response is set to "Standard."
This setting remains in effect until the HP Piano's power is turned off.

While holding down the [Demo Song/Key Touch] button, press the corresponding note (C7~E7).

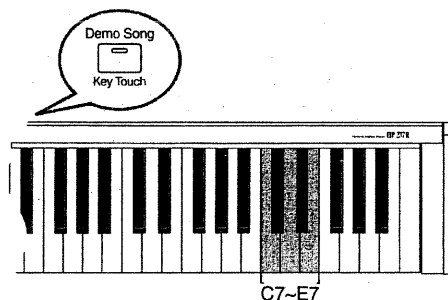

Key	Description
C7	Of the two selected tones, the sound assigned to the left Tone button sounds louder.
C#7	Of the two selected tones, the sound assigned to the left Tone button sounds somewhat louder.
D7	Standard
D#7	Of the two selected tones, the sound assigned to the left Tone button sounds somewhat quieter.
E7	Of the two selected tones, the sound assigned to the left Tone button sounds quieter.

MEMO

If you have recorded in Dual mode (p. 14), you can use the operation above to play back the performance with a different volume balance between the two layered tones.

Changing the depth of the Reverb

The depth of the Reverb Effect (p. 16) can be adjusted. There are eight levels of depth from which to choose. This is set to "4" when the power is turned on.

Hold down the [Reverb] button and press any Tone button.

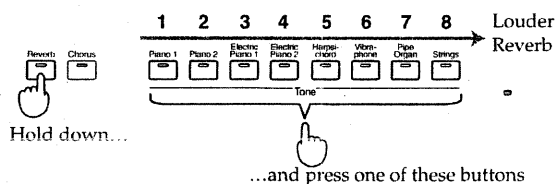

■ Checking the depth of the Reverb effect

Press and hold the [Reverb] button.

The Tone button indicators will blink to indicate the selected depth.

Changing the depth of the Chorus

The depth of the Chorus effect (p. 17) can be adjusted. There are eight levels of depth from which to choose. This is set to "4" when the power is turned on.

Holding down the [Chorus] button, press any Tone button.

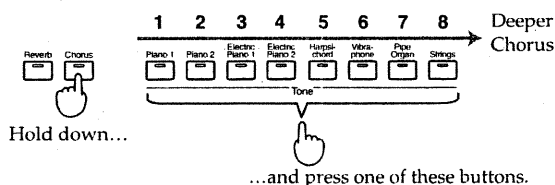

■ Checking the depth of the Chorus effect

Press and hold the [Chorus] button.

The Tone button indicators will blink to indicate the selected depth.

Changing the damper pedal's resonance

On acoustic pianos, when the damper pedal is pressed, additional strings are released to resonate with the sound of the keys that have been played, adding richness and breadth to the sound. The damper pedal on the HP Piano recreates this resonance when pressed. This is called "Sympathetic Resonance."

Eight levels of resonance are available. This is set to "4" when the power is turned on.

Hold down the [Reverb] and [Chorus] buttons, and press any Tone button.

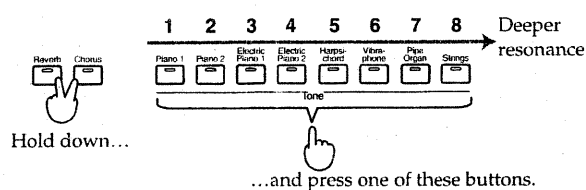

■ Checking the Resonance level

Press and hold the [Reverb] and [Chorus] buttons.

The Tone button indicators will blink to indicate the selected depth.

NOTE

This resonance works only with the piano tones.

Using classical tunings

Your instrument also allows you to perform using the tunings that were in use at the time when the pieces you wish to play (such as Baroque) were composed. Most modern music is composed based on the assumption that equal-tempered tuning, the tuning in use almost universally today, will be used. However, in the age of classical music there were a variety of different tunings in existence. Try out these tunings to find out what the chords in certain pieces sounded like originally.

"Equal temperament" is selected each time you switch on the HP Piano.

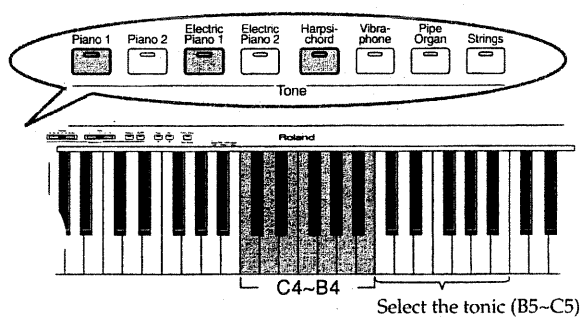

1. While holding down the [Piano 1], [Electric Piano 1], and [Harpsichord] buttons, press the corresponding key (C4~B4).

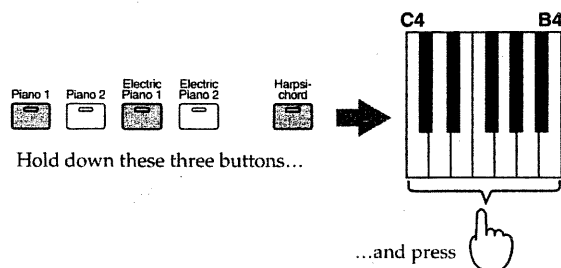

2. To select the keynote (tonic), hold down the [Piano 1], [Electric Piano 1], and [Harpsichord] buttons and press a key in the range of C5~B5.

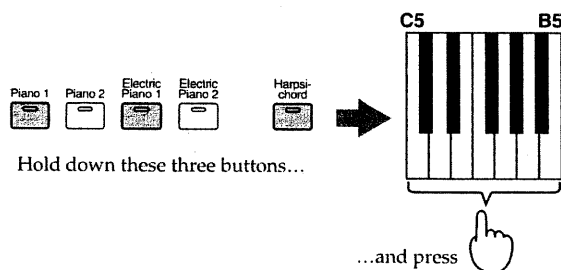

MEMO

When you want to perform using a tuning other than equal temperament, you'll need to specify the keynote (tonic for major, sixth for minor) appropriate for the key of the song you want to play.

Key	Temperament	Description
C4	Equal	With this tuning, the octave is divided into twelve equal intervals. Regardless of the interval, very little ambiguity is produced.
D4	Pythagorean	Developed in ancient Greece as a method of tuning that resolved the ambiguity of fourths and fifths. As a result, melodies sound cleaner, but a certain amount of ambiguity is produced with triads.
E4	Just Major	This tuning eliminates the ambiguity of fifths and thirds. This tuning is not suitable for melodies, and transposition is impractical, but rich sonorities can be produced by chords.
F4	Just Minor	Just Major and Minor tunings are different. You can get the same effects in the minor scale as in the major scale.
G4	Mean Tone	A partial compromise of the Just Major tuning, created to make transposition possible.
A4	Werckmeister	A combination of the Mean Tone and Pythagorean tunings. This tuning can be used in all keys.
B4	Kimberger	As a result of improvements made to the Mean Tone and Just temperaments, it is relatively tolerant towards transposition, and can be used to play in all keys.

NOTE

When performing in ensemble with other instruments, be aware that depending on the key, there may be some shifting of the pitch. Please tune to the other instruments in the ensemble.

NOTE

A recorded performance will be played using the temperament that was selected at the time you recorded it.

Changing tuning curves

Pianos are commonly tuned so pitches in the lower registers are adjusted relatively flat, and pitches in the higher registers are tuned sharper compared to equal temperament. This kind of tuning method for the piano is called "Stretch Tuning."

The graphic representation of the differences in pitch when comparing equal-tempered tuning with the actual tuning used is called the "Tuning Curve." Changing the tuning curve results in a subtle change in the sound of the chords. The HP Piano allows you to select different tuning curves. "Type 2" (Stretch Tuning) is the power-on default for the tuning curve.

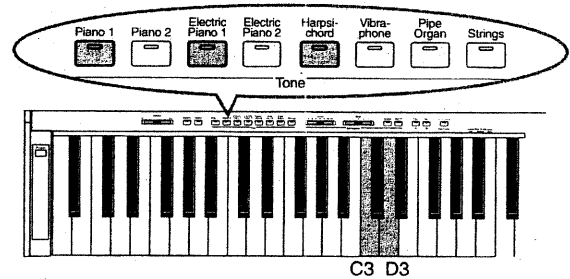

Hold down the [Piano 1], [Electric Piano 1], and [Harpsichord] buttons, press the "C3" to select "Type 1", or "D3" to select "Type 2".

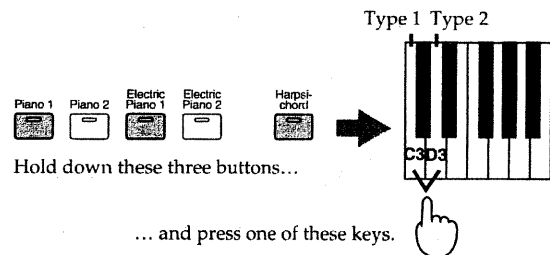

Key	Type	Description
C3	Type 1	Standard tuning curve. This is the right choice when using Dual Play (p. 14), or when playing in ensemble with other instruments.
D3	Type 2	A tuning curve wherein the low and high registers are widened slightly—low pitches are a little lower, the high pitches a little higher (Stretch Tuning). Appropriate for piano solos.

NOTE

This setting is only available with piano tones.

Disabling the buttons – Panel Lock

By using the panel lock function, you can disable the buttons with the exception of certain operations. This is a convenient way to prevent buttons from being pressed inadvertently, changing the settings.

When the panel is locked, only the following operations can be performed.

- Play using the piano sound
- Changing keyboard touch sensitivity (p. 23)
- Key Transpose (p. 23)
- Master Tuning (p. 24)

1. Turn the volume all the way down.

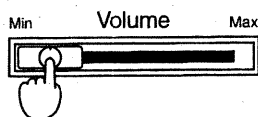

2. Press the [Power] switch to turn off the power.

3. While holding down the [Piano 1] button, press the [Power] switch to turn on the power.

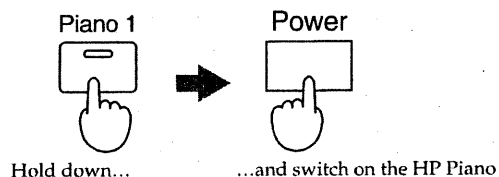

4. Adjust the volume.

Playing the keyboard now produces a Piano 1 sound. It will not be possible to switch to another sound.

Switching the power off and back on again releases the panel lock and returns the HP Piano to its usual state.

MEMO

Panel lock is also available for the other tones of the HP Piano: in step 3, hold down another Tone button than [Piano 1] while switching on the HP Piano. In that case, you can play the tone assigned to the button you pressed.

Panel Lock with the metronome enabled

If you turn on the power while holding down the Metronome [On/Off] button, it will also be possible to sound the metronome. You will also be able to adjust the metronome tempo, time signature, volume, and sound.

Connecting to MIDI devices

Read this chapter if you wish to connect the HP Piano to an external MIDI device.

If the HP Piano is connected to a MT series MIDI sequencer, etc., a performance recorded on the HP Piano can be transmitted to the MIDI sequencer. It is also possible to record the performance directly on the MIDI sequencer. The recorded performance can be saved on the MIDI sequencer.

When the HP Piano is connected to an MT series sequencer, the rich variety of sounds built into the MT series sequencer can be played from the HP Piano's keyboard.

About MIDI

MIDI, short for "Musical Instrument Digital Interface," was developed as a standard for the exchange of performance data between electronic instruments and computers.

The HP Piano is equipped with MIDI connectors to allow such exchange of performance data with external equipment and devices. Connecting the keyboard to other devices via these jacks provides you with an even greater variety of ways to use your HP Piano.

About the MIDI connectors

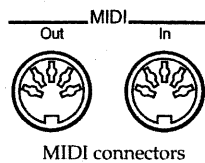

MIDI Out connector

Use a MIDI cable (sold separately) to connect from here to the MIDI In connector on the external MIDI device. Performance data detailing what has been played on the keyboard, and other data, such as that generated when a pedal is pressed, is sent out from here to external MIDI devices.

MIDI In connector

Use a MIDI cable (sold separately) to connect from here to the MIDI Out connector on the external MIDI device. MIDI messages sent from connected external equipment will be received here. As a result, the HP Piano will produce sound, change tones, or perform other operations.

Making the connections

NOTE

To prevent malfunction and/or damage to speakers or other devices, always turn down the volume, and turn off the power on all devices before making any connections.

1. Turn the volume down completely on all equipment.
2. Turn off the HP Piano and any other device to be connected.
3. Use an optional MIDI cable to connect the MIDI socket on the external MIDI device to the MIDI connector on the HP Piano.
Take a look at the connection examples for determining whether to use the HP Piano's "In" or "Out" connector.
4. Turn on the power to all equipment.
5. Adjust the volume.
6. You should also make the following settings as needed.

For details on making MIDI-related settings for the HP Piano, refer to p. 30-33.

Connecting to a sequencer (Roland MT series)

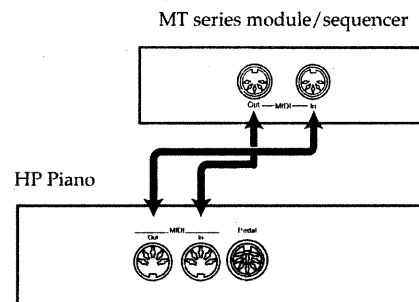

* The MT-80s has no MIDI Out connector.

Connecting to a MIDI sound module

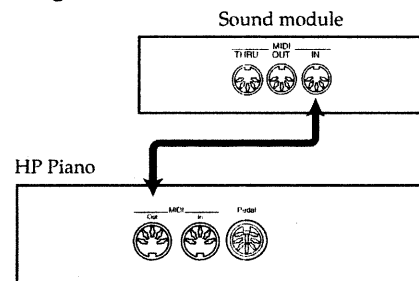

Tips for connecting an external MIDI Device

Here we will explain the "Local On/Off" and "Omni On/Off" settings that you need to be aware of when connecting the HP Piano to an external MIDI device.

■ Disconnecting the HP Piano's keyboard from its sound generator - Local On/Off

When the HP Piano is connected to a MIDI sequencer or the like, set it to Local Off.

As shown in the diagram, the data that is produced when you play the keyboard will reach the sound generator by two routes, (1) and (2), causing each note to be played in duplicate. To prevent this, select the Local Off setting to cut route (1).

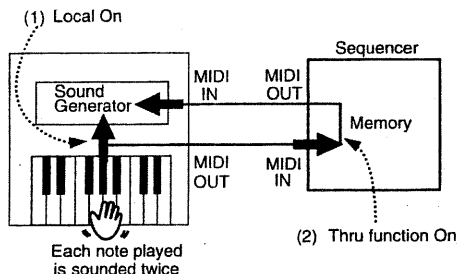

When Local is on:

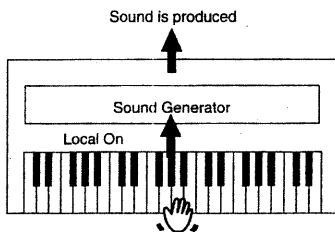

When Local is off:

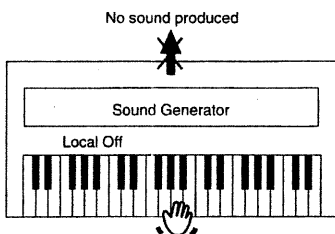

NOTE

Be aware that if you set your instrument to Local Off when no external MIDI device is connected, there will be no sound.

■ Switching Local on/off

Local On is set when the power is switched on.

While holding down the [Piano 1], [Piano 2], and [Harpischord] buttons, press the "B4" to turn the setting On; or press the "C5" to turn the setting Off.

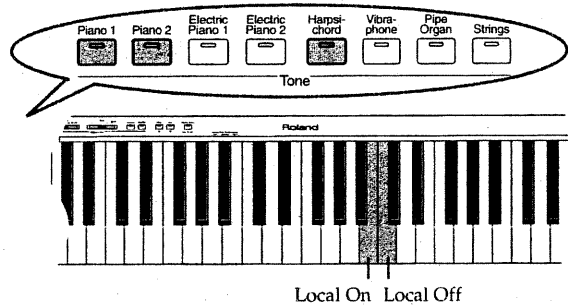

MEMO

If the HP Piano is connected to a Roland MT series (except MT-80s), it is not necessary to make the Local Off setting. When the power is turned on, the MT series will transmit a Local Off message. If you first switch on the HP Piano and then the MT series, the HP Piano will automatically be set to Local Off.

■ Receiving on all MIDI channels - Omni on/off

When set to Omni On, the HP Piano will sound as a result of received MIDI messages, no matter which channel the messages arrive on.

When set to Omni Off, the HP Piano will recognize only the messages that arrive on the MIDI channel that has been selected, as explained under "Set the MIDI Channel."

Switching Omni On/Off

Omni On is automatically set when the power is switched on.

Hold down the [Piano 1], [Piano 2], and [Harpischord] buttons, and press the "F4" to turn the setting On, or the "G4" to turn the setting Off.

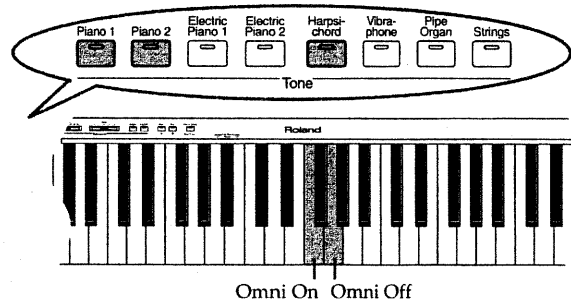

Setting the MIDI channel

MIDI features sixteen channels, numbered 1~16.

The connected devices must be set to use the same MIDI channels, otherwise no sound will be produced.

- In a setup where you wish to play the HP Piano and have another MIDI-equipped instrument or sound module play the same notes, you should first set the receive channel on your external device to the same channel you assign to the HP Piano for transmission.
- If using another MIDI keyboard as a master instrument, and you wish to have the HP Piano played by it, you would need to set the channel used for reception on the HP Piano to the same channel that the master keyboard transmits on.
- When a sequencer should play the HP Piano, you need to set the HP Piano's MIDI channel to the same channel that the desired MIDI track uses.

When the HP Piano is turned on, Channel "1" is selected.

Hold down the [Piano 1], [Piano 2], and [Harpischord] buttons and press the appropriate key (C2~D4) on the keyboard.

The HP Piano always uses the same MIDI channel for transmitting and receiving MIDI messages.

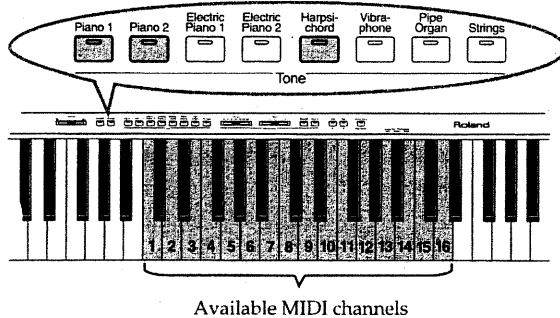

Selecting sounds via MIDI – Program Change

Program Changes are messages that tell an instrument to "switch to sound number x." When the other device receives this message, it will select the sound memory that corresponds to the number contained in the message.

When you press the HP Piano's Tone buttons to change tones, a Program Change message with the corresponding MIDI number is sent via the MIDI Out connector. Furthermore, a Program Change message received via the MIDI In connector causes the HP Piano to select the Tone whose MIDI number is contained in the changes the tone contained in the message.

At power-on, the HP Piano is set to "On" (transmit/receive Program Change messages).

If you set it to "Off," the HP Piano no longer sends Program Change messages when you select another Tone. Also, the HP Piano then ignores incoming Program Change messages.

Hold down the [Piano 1], [Piano 2], and [Harpischord] buttons and press the "E5" to turn the setting On, or the "F5" to turn the setting Off.

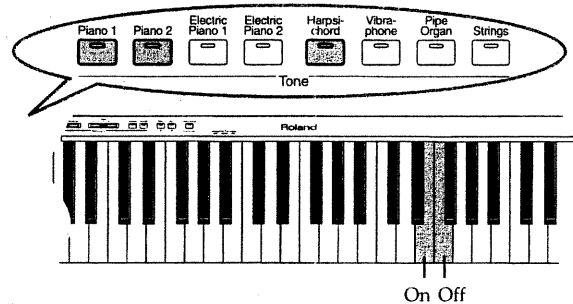

See below for the tones and their corresponding Program Numbers.

Program Number	Tone
01	Piano 1
02	Piano 2
03	—
04	Harpsichord
05	Vibraphone
06	Electric Piano 1
07	Electric Piano 2
08	Pipe Organ
09	Strings
10	Piano1 + Piano2
11	Piano1 + Harpsichord
12	Piano1 + Vibraphone
13	Piano1 + Electric Piano1
14	Piano1 + Electric Piano2
15	Piano1 + Pipe Organ
16	Piano1 + Strings
17	Piano2 + Harpsichord
18	Piano2 + Vibraphone
19	Piano2 + Electric Piano1
20	Piano2 + Electric Piano2
21	Piano2 + Pipe Organ
22	Piano2 + Strings
23	Harpsichord + Vibraphone
24	Harpsichord + Electric Piano1
25	Harpsichord + Electric Piano2
26	Harpsichord + Pipe Organ
27	Harpsichord + Strings
28	Vibraphone + Electric Piano1
29	Vibraphone + Electric Piano2
30	Vibraphone + Pipe Organ
31	Vibraphone + Strings
32	Electric Piano1 + Electric Piano2
33	Electric Piano1 + Pipe Organ
34	Electric Piano1 + Strings
35	Electric Piano2 + Pipe Organ
36	Electric Piano2 + Strings
37	Pipe Organ + Strings
38	Acoustic Bass/Piano1
39	Acoustic Bass/Piano2
40	Strings/Harpsichord
41	Acoustic Bass/Vibraphone
42	Acoustic Bass/Electric Piano1
43	Acoustic Bass/Electric Piano2
44	Pipe Organ/Harpsichord
45	Strings/Piano1

Turning transmission and reception of Control Changes on/off

Messages known as “Control Changes” are used to convey information about the instances where you press a pedal, or switch the Chorus or Reverb effect on/off.

Each time the power is turned on, the HP Piano is set to “On” (transmit/receive all Control Change messages).

If you set it to “Off” the HP Piano no longer transmits or receives Control Change messages.

Hold down the [Piano 1], [Piano 2], and [Harpsichord] buttons and press the “A5” to turn the setting on, or the “B5” to turn the setting off.

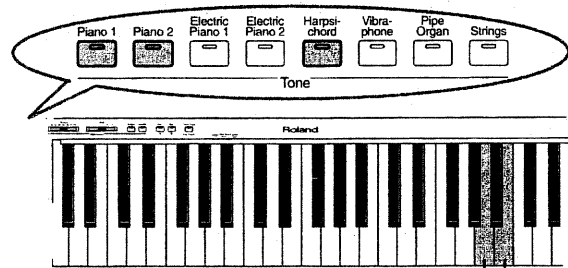

Control Changes on Off

MEMO

If you want to know more about Control Change numbers, please refer to the “MIDI Implementation Chart” at the end of this manual.

Transmitting Recorder data from MIDI Out

If this setting is on, performance data recorded on the HP Piano can be transmitted from the MIDI Out connector. At power-on, this function is switched off.

Hold down the [Piano 1], [Piano 2], and [Harpichord] buttons and press the “D6” to turn the setting On, or the “E6” to turn the setting Off.

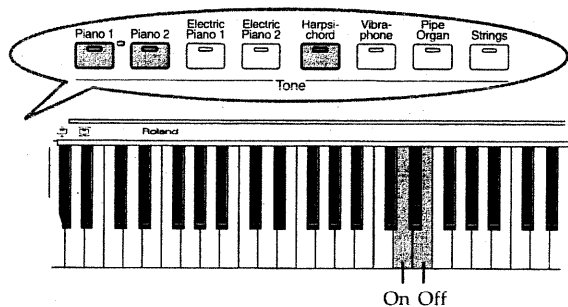

The recorded data will be erased when you switch off the HP Piano. If you wish to keep the performance, use the following procedure.

- 1. Connect a MIDI sequencer such as the MT series (p. 29).**
- 2. Record the performance on the HP Piano (p. 20).**
- 3. Activate the Recorder transmit function.**
- 4. Start recording with the connected MIDI device.**
- 5. Start playback of the recorded song on the HP Piano.**
- 6. When playback ends, stop recording on the connected MIDI device.**
- 7. Save the data of the external sequencer to a floppy disk or other media.**

Connecting audio equipment

When you connect the HP Piano to audio equipment, you can amplify the HP Piano's sounds via the speakers of your stereo, a PA, and the like, or record your performances on a tape recorder or other recording device.

■ Connectors

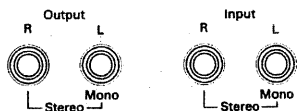

Output jacks

You can connect audio equipment using audio cables (sold separately) and play the HP Piano's sounds through the speakers on the connected equipment, or record your performances on a tape recorder or other recording device. If the input of the connected device is monaural, you must use the L/Mono jack.

Input jacks

You can connect another sound source, such as audio equipment or an electronic instrument using audio cables (sold separately) and play the sounds of the connected device through the speakers on the HP Piano. If the output of the connected device is monaural, connect it to the INPUT L/Mono jack.

■ Making the connections

- * To prevent malfunction and/or damage to speakers or other devices, always turn down the volume, and turn off the power on all devices before making any connections.
- * Always make sure to have the volume level turned down before switching on power. Even with the volume all the way down, you may still hear some sound when the power is switched on, but this is normal, and does not indicate a malfunction.

○ Playing the HP Piano's sounds through the speakers of external audio equipment, or recording your performances

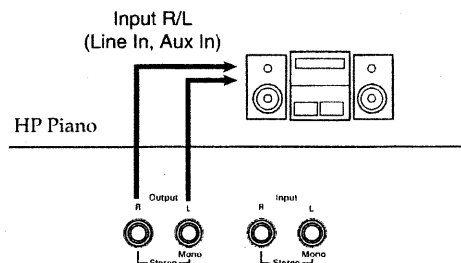

1. Turn the volume all the way down on the HP Piano and on the device you're about to connect.

2. Turn off the power to the HP Piano and other connected equipment.
3. Use audio cables (sold separately) to make the connection.
4. Turn on the power of the HP Piano.
5. Switch on the connected device.
6. Adjust the volume level on the HP Piano and the connected device.

When recording HP Piano performances on a recording device

7. Start recording with the connected device.
8. Play the keyboard.
9. When the performance ends, stop recording on the connected equipment.

○ Connecting external signal sources/instruments to the HP Piano

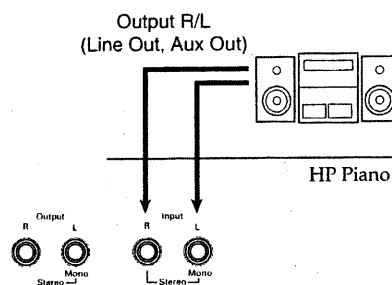

1. Turn the volume all the way down on the HP Piano and on the device you're about to connect.
2. Turn off the power to the HP Piano and other connected equipment.
3. Use audio cables (sold separately) to make the connection.
4. Turn on the power to the connected equipment.
5. Turn on the HP Piano.
6. Adjust the volume level on the HP Piano and the connected device.

○ Turning the power off after use

After use, follow the steps below to switch off the power.

1. Turn the volume all the way down on the HP Piano and on the connected device.
2. Turn off the power to the HP Piano.
3. Turn off the connected equipment.

Troubleshooting

If you are encountering problems with the unit, please read the section below before assuming that there is a malfunction.

The piano cannot be switched on

- Is the power cord properly connected? (p. 8)

No sound is produced

- Is the [Volume] knob set to the minimum position? (p. 9)
- Are headphones connected? (p. 11)
- Is Local On/Off set to "Off"? (p. 30)

Demo songs do not play

- Is Panel Lock on? (p. 28)

Metronome does not sound

- Is Panel Lock on? (p. 28)

Buttons do not function

- Is Panel Lock on? (p. 28)

Keyboard sound does not change

- Is Panel Lock on? (p. 28)

Two sounds are produced when the keyboard is played

- Is the keyboard in Dual mode? (p. 14)

The pitch of the keyboard sounds incorrect

- Is the Master Tuning setting correct? (p. 24)
- Is the Key Transpose setting correct? (p. 23)
- Is the temperament or tuning curve setting correct? (p. 26, p. 27)

The pedals are not functioning, or only intermittently

- Are the pedals connected properly?
Make sure the pedal cord is securely connected to the pedal jack on the back of the unit.

Can't record

- Is Panel Lock on? (p. 28)
- Does the [Demo Song/Key Touch] light?
Press the [Demo Song/Key Touch] button; the indicator goes out (p. 12).
- The metronome or count-in sound is not recorded.

The recorded performance has been deleted

- The performance data that you recorded will disappear when you switch off the HP Piano (p. 20).
- If you record again after recording, the first-recorded performance will be erased (p. 20).

Sound is distorted

- Is the [Volume] slider set to the maximum position? (p. 9)

Bass notes sound wrong/buzzing or vibration occurs

- If you can't hear the problem in the headphones:
When playing at high volumes, resonance may occur in the piano itself or in objects near the piano. At times, other objects in the room, such as fluorescent lights or glass doors, could start vibrating. This becomes more noticeable when playing in the lower register at high volume. To minimize such unwanted resonance, please observe the following:
 - Locate the instrument so it is 10–15 cm away from the walls.
 - Reduce the volume.
 - Increase the distance from the resonating object.
- If you can hear the problem in the headphones:
There may be for a different reason. Please contact your dealer.

In the upper range, the sound changes abruptly beyond a certain key

- On an acoustic piano, notes in the top one-and-a-half octaves continue to sound until they decay naturally, regardless of the damper pedal. There is a difference in the timbre as well. Roland pianos faithfully simulate such characteristics of the acoustic piano. On the HP Piano, the range that is affected by the damper pedal depends on the Key Transpose setting.

<When the HP Piano is connected to an external device>

No sound is produced

- Is the power to all equipment turned on?
- Are the connections between HP Piano and the MIDI sequencer or the other external devices correct? (p. 29)
- Is the MIDI channel setting correct? (p. 31)
- Is the Omni On/Off setting correct? (p. 30)

Strange sounds (or two sounds) are produced when the HP Piano is played

- With the sequencer's "Thru" function on, the notes you play may sound twice. Set the HP Piano to Local off (p. 30).

The volume level of the instrument connected to the input jack is too low

- Are you using a connection cable that contains a resistor?
Use a connection cable that does not contain a resistor.

Functions assigned to the keyboard

Convenient functions

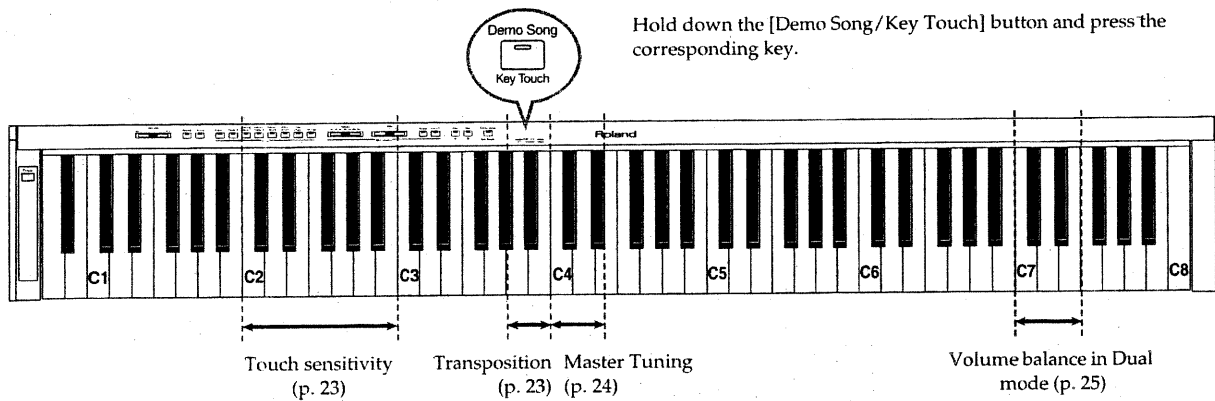

Functions related to the HP Piano's tuning

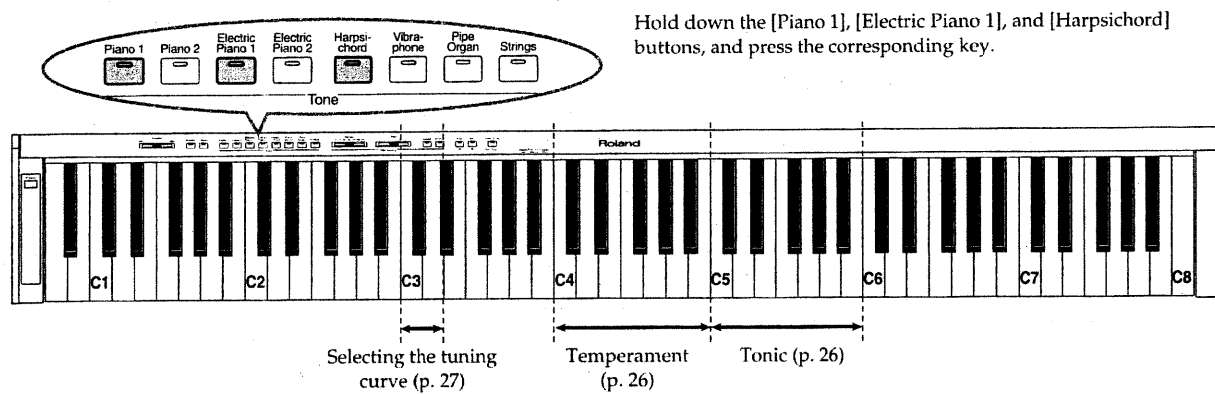

Functions for MIDI

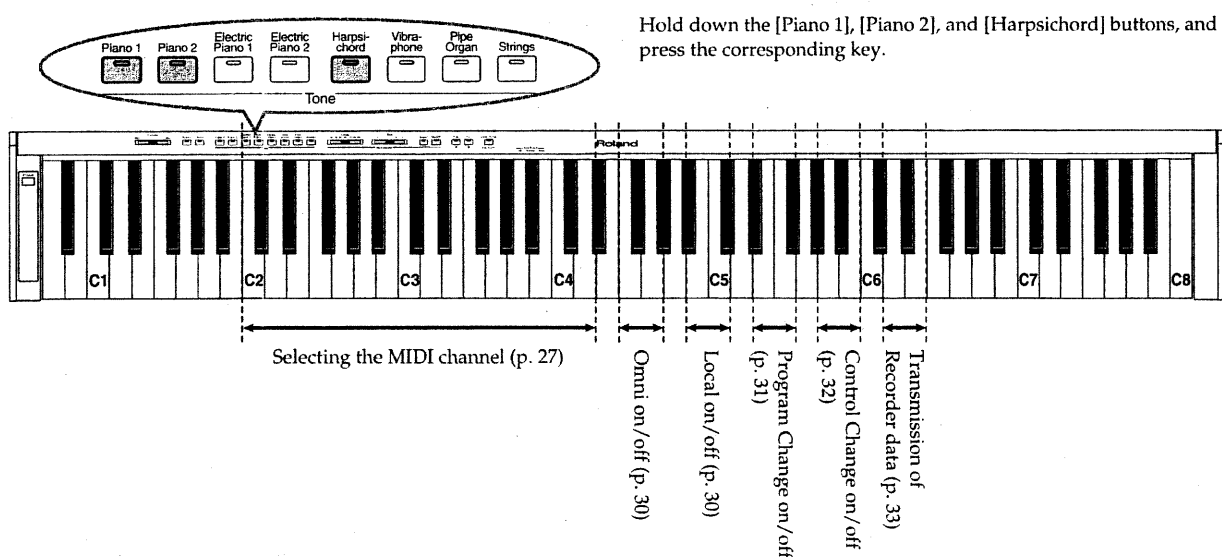

Specifications

Roland Digital Piano

<Keyboard>

- Keyboard
88 keys (Progressive Hammer Action Mechanism)
- Touch Sensitivity
3 levels
- Keyboard mode
Whole
Dual
Split

< Sound generator >

- Maximum polyphony
64 voices
- Tones
9: Piano 1, Piano 2, Electric Piano 1, Electric Piano 2,
Harpsichord, Vibraphone, Pipe Organ, Strings, Acoustic
Bass (in Split mode)
- Effects
Chorus (8 levels)
Reverb (8 levels)
Sympathetic Resonance (8 levels)
- Key Transposition
-6~+5 (semitone steps)
- Temperament
7 types, selectable tonic
- Stretched Tuning
2 types
- Master Tuning
415.3 Hz~466.2 Hz (0.1 Hz steps)

<Composer>

- Metronome
Beat: 0, 2, 3, 4, 6
Volume: 8 levels
Sounds: 3 types
- Tracks
1 track
- Song
1 song
- Note storage
Approx. 5,000 notes
- Tempo
Quarter note = 40~208
- Resolution
96 ticks per quarter note
- Control
Play/Stop, Rec, Tempo

<Others>

- Pedals
Damper, Sostenuto, Soft
- Speakers
HP-237Re/PE/Le 16cm x2
HP-737 16cm x2 (woofer), 5.5cm x2 (tweeter)
- Rated power output
20 W x 2 RMS
- Connectors
Headphone jacks (stereo) x 2
Input jacks (R, L/Mono)
Output jacks (R, L/Mono)
MIDI connectors (In, Out)
Pedal connector
- Power supply
AC 117 V, AC 230 V, AC 240 V
- Power consumption
60W (117V), 45W (230/240V)
- Cabinet finish
HP-237Re Simulated Rosewood
HP-237PE Polished ebony (black)
HP-237Le Light Oak
HP-737 Mini Grand, polished ebony
- Dimensions
HP-237Re Piano: 1393 (W) x 523 (D) x 227 (H) mm
HP-237Le Stand: 1392 (W) x 470 (D) x 638 (H) mm
Total: 1393 (W) x 523 (D) x 865 (H) mm
HP-237PE Piano: 1405 (W) x 534 (D) x 228 (H) mm
Stand: 1392 (W) x 470 (D) x 638.5 (H) mm
Total: 1405 (W) x 534 (D) x 866.5 (H) mm
HP-737 Total: 1400 (W) x 940 (D) x 945 (H) mm
- Weight
HP-237Re Piano: 48.0kg
HP-237Le Stand: 18.5kg
Total: 66.5 kg
HP-237PE Piano: 48.0kg
Stand: 18.5kg
Total: 66.5 kg
HP-737 Total: 105kg
- Accessories
Owner's manual
Power cable

* In the interest of product improvement, the specifications and/or appearance of this unit are subject to change without prior notice.

List of demo songs

No.	Title	Composer	Copyright
1-1	Intro	J. Maul	© 1991, 1999 Roland UK
1-2	Je Te Veux	E. Satie	© 1997 Roland Corporation
1-3	Golliwog's Cakewalk	C. Debussy	© 1996 Roland Corporation
1-4	"Fröhlicher Landmann" from "Album Für Die Jugend" Op. 68	R. Schumann	© 1996 Roland Corporation
2-1	Bagatelle "Für Elise" WoO. 59	L. v. Beethoven	© 1994 Roland Corporation
2-2	Arabesque No. 1 in E-Major	C. Debussy	© 1994 Roland Corporation
2-3	Salut D'Amour Op. 12	E. Elgar	© 1996 Roland Corporation
2-4	"Troika Drive: November" from "The Seasons," Op. 37	P. Tchaikovsky	© 1996 Roland Corporation
3-1	A Maiden's Prayer	T. Badarzewska	© 1996 Roland Corporation
3-2	"Promenade" from "Tableaux d'une exposition"	M. Musorgsky	© 1995 Roland Corporation
3-3	On Wings Of Song	F. Mendelssohn	© 1996 Roland Corporation
3-4	Moment musicaux No. 3, Op. 94-3	F. Schubert	© 1994 Roland Corporation
4-1	No. 14 "La Styrienne" from "25 Easy Studies" Op. 100	F. Burgmüller	© 1992 Roland Corporation
4-2	Turkish March (Piano Sonata No. 11 in A Major, 3rd Movement "Alla Turca")	W. A. Mozart	© 1994 Roland Corporation
4-3	Rondo Brillante "Aufforderung Zum Tanz" in D-flat Major, Op. 65	C. M. v. Weber	© 1994 Roland Corporation
4-4	"Frühlingslied" from "Lieder Ohne Worte Heft 5," Op. 62-6	F. Mendelssohn	© 1996 Roland Corporation
5-1	Cantata BWV. 147 (Jazz Arranged)	J. S. Bach / Naoki Nishi	© 1993 Roland Corporation
5-2	Gymnopedie No. 1	E. Satie	© 1997 Roland Corporation
5-3	Fantasia-Impromptu Op.66	F. Chopin	© 1994 Roland Corporation
5-4	Etude No. 5 in G-flat Major "Black Keys," Op. 10-5	F. Chopin	© 1990 Roland Corporation
6-1	Etude No.3 in E Major "Chanson De L'Adieu," Op. 10-3	F. Chopin	© 1992 Roland Corporation
6-2	Mazurka No.5 in B-flat Major, Op. 7-1	F. Chopin	© 1995 Roland Corporation
6-3	Valse No. 6 in D-flat Major, Op. 64-1 "Petit Chien"	F. Chopin	© 1990 Roland Corporation
6-4	Nocturne No. 2 in E-flat Major, Op. 9-2	F. Chopin	© 1993 Roland Corporation
7-1	Fly Free	J. Maul	© 1992 Roland Corporation
7-2	Piano Sonata No. 14 in C-sharp Minor, "Moonlight" 1st Movement	L. v. Beethoven	© 1998 Roland Corporation
7-3	"Berceuse" from "Dolly," Op. 56	G. Fauré	© 1995 Roland Corporation
7-4	Slavonic Dance No. 10, Op. 72-2	A. Dvořak	© 1998 Roland Corporation
8-1	Mood/Ending	J. Maul	© 1991, 1999 Roland UK
8-2	3-Romances Sans Paroles No. 3, Op. 17	G. Fauré	© 1996 Roland Corporation
8-3	"Clair de lune" from "Suite Bergamasque"	C. Debussy	© 1990 Roland Corporation
8-4	"Träumerei" from "Scenes From Childhood" Op. 15	R. Schumann	© 1997 Roland Corporation

DIGITAL PIANO
 Model HP 237 Re, HP 237PE
 HP 237Le, HP 737

MIDI Implementation Chart

Date : Jun. 1, 2001
 Version : 1.00

Function...	Transmitted	Recognized	Remarks
Basic Default Channel Changed	1 1-16	1 1-16	
Mode Default Messages Altered	Mode 1 x *****	Mode 1 OMNI ON/OFF	.
Note Number : True Voice	15-113 *****	0-127 15-113	
Velocity Note ON Note OFF	O x 8n v=64	O x	
After Key's Touch Ch's	x x	x x	
Pitch Bend	x	x	
Control Change 6, 38 7 11 64 66 67 91 93 100, 101	O *1 x x O *1 O O *1 O *1 O *1 O *1 O *1 O *1	O *1 O *1 *2 O *1 *2 O *1 *2 O *1 *2 O *1 *2 O *1 O *1 O *1 O *1	Data entry Volume Expression Hold 1 Sostenuto Soft Effect1 depth (Reverb) Effect3 depth (Chorus) RPN LSB, MSB
Prog Change : True Number	O (0-44) *1 *****	O (0-127) *1 0-44	
System Exclusive	O	O	
System : Song Pos Common : Song Sel : Tune	x x x	x x x	
System : Clock Real Time : Commands	x x	x x	
Aux : All sound off Message : Reset all controllers : Local ON/OFF : All Notes OFF : Active Sense : System Reset	x x x x O x	x O O O (123-127) O O x	
Notes	*1 O x is selectable. *2 This message can affect only MIDI notes.		

Mode 1 : OMNI ON, POLY Mode 2 : OMNI ON, MONO
 Mode 3 : OMNI OFF, POLY Mode 4 : OMNI OFF, MONO

O : Yes
 X : No

Information

When you need repair service, call your nearest Roland Service Center or authorized Roland distributor in your country as shown below.

AFRICA

EGYPT
Al Fanny Trading Office
P.O. Box 2904,
El Horrieh Heliopolis, Cairo,
EGYPT
TEL: (02) 4185531

REUNION
Maison FO - YAM Marcel
25 Rue Jules Hermann,
Chaudron - BP79 97 491
Ste Clotilde Cedex,
REUNION ISLAND
TEL: 28 29 16

SOUTH AFRICA
That Other Music Shop
(PTY) Ltd.
11 Melk St., Braamfontein,
Johannesburg,
Republic of SOUTH AFRICA
P.O. Box 32918, Braamfontein 2017
Republic of SOUTH AFRICA
TEL: (011) 403 4105

SAIGON MUSIC
138 Tran Quang Khai St.,
District 1
Ho Chi Minh City
VIETNAM
TEL: (08) 844-4068

PAUL BOTHNER (PTY) LTD.
17 Werdmuller Centre Claremont
7700
Republic of SOUTH AFRICA
P.O. Box 23032
Claremont, Cape Town
SOUTH AFRICA, 7735
TEL: (021) 674 4030

ASIA

CHINA
Beijing Xinghai Musical
Instruments Co., Ltd.
6 Huangmuchiang Chao Yang
District, Beijing, CHINA
TEL: (010) 6774 7491

HONG KONG
Tom Lee Music Co., Ltd.
Service Division
22-32 Pun Shan Street, Tsuen
Wan, New Territories,
HONG KONG
TEL: 2415 0911

INDIA
Rivera Digitec (India) Pvt. Ltd.
409, Nirman Kendra Mahalaxmi
Flats Compound Off. Dr. Edwin
Moses Road, Mumbai-400011,
INDIA
TEL: (022) 498 3079

INDONESIA
PT Citra IntiRama
Jl. Cideng Timur No. 15J-150
Jakarta Pusat
INDONESIA
TEL: (021) 6324170

KOREA
Cosmos Corporation
1461-9, Seocho-Dong,
Seocho Ku, Seoul, KOREA
TEL: (02) 3486-8855

MALAYSIA
Bentley Music SDN BHD
140 & 142, Jalan Bukit Bintang
55100 Kuala Lumpur, MALAYSIA
TEL: (03) 2443333

PHILIPPINES
G.A. Yupangco & Co. Inc.
339 Gil J. Puyat Avenue
Makati, Metro Manila 1200,
PHILIPPINES
TEL: (02) 899 9801

SINGAPORE
Swee Lee Company
150 Sims Drive,
SINGAPORE 387381
TEL: 748-1669

CRISTOFORI MUSIC PTE LTD
Blk 3014, Bedok Industrial Park E.
#02-2148, SINGAPORE 489980
TEL: 243 9555

TAIWAN
ROLAND TAIWAN
ENTERPRISE CO., LTD.
Room 5, 9th. No. 112 Chung Shan
N. Road Sec.2, Taipei, TAIWAN,
R.O.C.
TEL: (02) 2561 3339

THAILAND
Theera Music Co., Ltd.
330 Vong NakhornKasem, Sov 2,
Bangkok 10100, THAILAND
TEL: (02) 2248821

VIETNAM
Theera Music Co., Ltd.
330 Vong NakhornKasem, Sov 2,
Bangkok 10100, THAILAND
TEL: (02) 2248821

VIETNAM
Theera Music Co., Ltd.
330 Vong NakhornKasem, Sov 2,
Bangkok 10100, THAILAND
TEL: (02) 2248821

AUSTRALIA/NEW ZEALAND

AUSTRALIA
Roland Corporation
Australia Pty., Ltd.
38 Campbell Avenue
Dee Why West, NSW 2099
AUSTRALIA
TEL: (02) 9982 8266

NEW ZEALAND
Roland Corporation (NZ) Ltd.
97 Mt. Eden Road, Mt. Eden,
Auckland 3, NEW ZEALAND
TEL: (09) 3098 715

CENTRAL/LATIN AMERICA

ARGENTINA
Instrumentos Musicales S.A.
Florida 656 2nd Floor
Office Number 206A
Buenos Aires
ARGENTINA, CP1005
TEL: (54-11) 4-393-6057

BRAZIL
Roland Brasil Ltda.
R. Coronel Octaviano da Silveira
203 05522-010
Sao Paulo BRAZIL
TEL: (011) 3743 9377

COSTA RICA
JUAN Bansbach
Instrumentos Musicales
Ave. 1, Calle 11, Apartado 10237,
San Jose, COSTA RICA
TEL: (506) 258-0211

CHILE
Comercial Fancy S.A.
Avenida Rancagua #0330
Providencia Santiago, CHILE
TEL: 56-2-373-9100

EL SALVADOR
OMNI MUSIC
75 Avenida Notre YY Alameda,
Juan Pablo 2, No. 4010
San Salvador, EL SALVADOR
TEL: (503) 262-0788

MEXICO
Casa Veerkamp, s.a. de c.v.
Av. Toluca No. 323, Col. Olivar
de los Padres 01760 Mexico D.F.
MEXICO
TEL: (525) 668 04 80

La Casa Wagner de
Guadalajara s.a. de c.v.
Av. Corona No. 202 S.J.
Guadalajara, Jalisco Mexico
C.P. 44100 MEXICO
TEL: (3) 613 1414

PANAMA
SUPRO MUNDIAL, S.A.
Boulevard Andrews, Albrook,
Panama City,
REP. DE PANAMA
TEL: (507) 315-0101

PARAGUAY
Distribuidora De
Instrumentos Musicales
J.E. Olear y ESQ. Manduvira
Edificio, El Dorado Planta Baja
Asuncion PARAGUAY
TEL: 595-21-492147

PERU
VIDEO Broadcast S.A.
Portinari 199 (ESQ. HALES),
San Borja, Lima 41,
REP. OF PERU
TEL: 51-14-758226

URUGUAY
Todo Musica S.A.
Cuareim 1844, Montevideo,
URUGUAY, CP11200
TEL: 5982-924-2335

VENEZUELA
Musicland Digital C.A.
Av. Francisco de Miranda,
Centro Parque de Cristal, Nivel
C2 Local 20 Caracas
VENEZUELA
TEL: (02) 285 9218

EUROPE

AUSTRIA
Roland Austria GES.M.B.H.
Siemensstrasse 4, P.O. Box 74,
A-6063 RUM, AUSTRIA
TEL: (0512) 26 44 260

BELGIUM/HOLLAND/LUXEMBOURG
Roland Benelux N. V.
Houtstraat 3, B-2260, Oevel,
(Westerlo) BELGIUM
TEL: (014) 575811

DENMARK
Roland Scandinavia A/S
Nordhavnsvej 7, Postbox 880,
DK-2100 Copenhagen
DENMARK
TEL: (039)16 6200

FRANCE
Roland France SA
4, Rue Paul Henri SPAAK,
Parc de l'Espérance, F77 462 St.
Thibault, Lagny Cedex FRANCE
TEL: 01 600 73 500

FINLAND
Roland Scandinavia As,
Filial Finland
Lautasaarentie 54 B
Fin-00201 Helsinki, FINLAND
TEL: (9) 682 4020

GERMANY
Roland Elektronische
Musikinstrumente HmbH.
Oststrasse 96, 22844 Norderstedt,
GERMANY
TEL: (040) 52 60090

GREECE
STOLLAS S.A.
Music Sound Light
155, New National Road
26422 Patras, GREECE
TEL: 061-435400

HUNGARY
Intermusica Ltd.
Warehouse Area "DEPO" P/83
11-2046 Torokbalint, HUNGARY
TEL: (23) 511011

IRELAND
Roland Ireland
Audio House, Belmont Court,
Donnybrook, Dublin 4,
Republic of IRELAND
TEL: (01) 2603501

ITALY
Roland Italy S. p. A.
Viale delle Industrie 8,
20020 Arese, Milano, ITALY
TEL: (02) 937-78300

NORWAY
Roland Scandinavia Avd.
Kontor Norge
Lilleakerveien 2 Postboks 95
Lilleaker N-0216 Oslo
NORWAY
TEL: 273 0074

POLAND
P. P. H. Brzostowicz
Ul. Gibraltarska 4,
PL-03664 Warszawa POLAND
TEL: (022) 679 44 19

PORTUGAL
Tecnologias Musica e Audio,
Roland Portugal, S.A.
RUA DE SANTA CARARINA
131/133, 4000-450 PORTO
PORTUGAL
TEL: (022) 208 4456

ROMANIA
FBS LINES
Plata Libertatii 1,
RO-4200 Ceorgheni
TEL: (066) 164-609

RUSSIA
Slami Music Company
Sadajava-Triumfalnaja st., 16
103006 Moscow, RUSSIA
TEL: (095 209 2193)

SPAIN
Roland Electronics
de España, S. A.
Calle Bolivia 239, 08020
Barcelona, SPAIN
TEL: (93) 308 1000

SWEDEN
Roland Scandinavia A/S
SWEDISH SALES OFFICE
Danvik Center 28, 2 tr,
S-131 30 Nacka SWEDEN
TEL: (08) 702 0020

SWITZERLAND
Roland (Switzerland) AG
Musitronic AG
Gebenstrasse 5, Postfach,
CH-4410 Liestal, SWITZERLAND
TEL: (061) 921 1615

UKRAINE
TIC-TAC
Mira Str. 19/108
P.O. Box 180
295400 Munkachevo, UKRAINE
TEL: (03131) 414-40

UNITED KINGDOM
Roland (U.K.) Ltd.
Atlantic Close, Swansea
Enterprise Park, SWANSEA
SA7 9FL,
UNITED KINGDOM
TEL: (01792) 700139

MIDDLE EAST

BAHRAIN
Moon Stores
Bab Al Bahrain Road,
P.O. Box 20077
State of BAHRAIN
TEL: 211 005

CYPRUS
Radex Sound Equipment Ltd.
17 Diagonou St., P.O. Box 2046,
Nicosia CYPRUS
TEL: (02) 453 426

ISRAEL
Halilit P. Greenspoon &
Sons Ltd.
8 Reizif Ha'aliya Hashviva St.
Tel-Aviv-Yafo ISRAEL
TEL: (03) 6823666

JORDAN
AMMAN Trading Agency
Prince Mohammed St. P.O. Box
825 Amman 11118 JORDAN
TEL: (06) 4641300

KUWAIT
Easa Husain Al-Yousifi
Abdullah Salem Street,
Safat KUWAIT
TEL: 5719499

LEBANON
A. Chahine & Fils
P.O. Box 16-5857 Gergi Zeidan St.
Chahine Building, Achrafieh,
Beirut, LEBANON
TEL: (01) 335799

QATAR
Al Emadi Co. (Badi Studio
& Stores)
P.O. Box 62,
DOHA QATAR
TEL: 4423-554

SAUDI ARABIA
Dawiah Universal
Electronics APL
Comiche Road, Aldossary Bldg.,
1st Floor
SAUDI ARABIA
P.O. Box 2154, Alkhobar 31952
SAUDI ARABIA
TEL: (03) 898 2081

SYRIA
Technical Light & Sound
Center
Khaled Ibn Al Walid St.
P.O. Box 13520
Damascus - SYRIA
TEL: (011) 2235 384

TURKEY
Barkat muzik aletleri ithalat
ve ihracat Ltd Sti
Sirselsöler cad. Güneç is hani 84-
86/6, Taksim, Istanbul, TURKEY
TEL: (0212) 2499324

U.A.E.
Zak Electronics & Musical
Instruments Co. L.L.C.
Zabed Road, Al Sherqiy Bldg.,
No. 14, Grand Floor DUBAI
U.A.E.
TEL: (04) 3360715

NORTH AMERICA

CANADA
Roland Canada Music Ltd.
(Head Office)
5480 Parkwood Way Richmond
B. C., V6V 2M4 CANADA
TEL: (0604) 270 6626

Roland Canada Music Ltd.
(Toronto Office)
Unit 2, 109 Woodbine Downs
Blvd, Etobicoke, ON
M9W 6Y1 CANADA
TEL: (0416) 213 9707

U. S. A.
Roland Corporation U.S.
5100 S. Eastern Avenue
Los Angeles, CA 90040-2938,
U. S. A.
TEL: (323) 890 3700

For E.C. Countries

This product complies with EC directives

- LOW VOLTAGE 73/23
- EMC 89/336"

Dieses instrument entspricht folgenden EG-Verordnungen:

- NIEDRIGE SPANNUNG 73/23
- EMC 89/336"

Cet instrument est conforme aux directives CE suivantes:

- BASSE TENSION 73/23
- EMC 89/336"



Questo prodotto è conforme alle seguenti direttive CEE

- BASSA TENSIONE 73/23
- EMC 89/336"

Dit instrument beantwoordt aan de volgende EG richtlijnen:

- LAGE SPANNING 73/23
- EMC 89/336"

Este producto cumple con las siguientes directrices de la CE

- BAJO VOLTAJE 73/23
- EMC 89/336"

For the USA

FEDERAL COMMUNICATIONS COMMISSION RADIO FREQUENCY INTERFERENCE STATEMENT

This equipment has been tested and found to comply with the limits for a Class B digital device, pursuant to Part 15 of the FCC Rules. These limits are designed to provide reasonable protection against harmful interference in a residential installation. This equipment generates, uses, and can radiate radio frequency energy and, if not installed and used in accordance with the instructions, may cause harmful interference to radio communications. However, there is no guarantee that interference will not occur in a particular installation. If this equipment does cause harmful interference to radio or television reception, which can be determined by turning the equipment off and on, the user is encouraged to try to correct the interference by one or more of the following measures:

- Reorient or relocate the receiving antenna.
- Increase the separation between the equipment and receiver.
- Connect the equipment into an outlet on a circuit different from that to which the receiver is connected.
- Consult the dealer or an experienced radio/TV technician for help.

Unauthorized changes or modification to this system can void the users authority to operate this equipment.
This equipment requires shielded interface cables in order to meet FCC class B Limit.

For Canada

CLASS B

NOTICE

This digital apparatus does not exceed the Class B limits for radio noise emissions set out in the Radio Interference Regulations of the Canadian Department of Communications.

CLASS B

AVIS

Cet appareil numérique ne dépasse pas les limites de la classe B au niveau des émissions de bruits radioélectriques fixés dans le Règlement des signaux parasites par le ministère canadien des Communications.

Roland®
K6018444

UPC K6018444



18941

HP 737 - HP 237 Re/PE/Le

RES 306-01

Printed in Italy by Amball Grafiche srl - Ancona

06-01 - HP 737 - HP 237 Re/PE/Le - O.M./E-D-F-Il-Sp-OI

Roland®

602153455