

Roland[®]

Roland Digital Piano



HP 535 / HP 335

Owner's Manual

Before using this unit, carefully read the sections entitled: "IMPORTANT SAFETY INSTRUCTIONS" (p.2), "USING THE UNIT SAFELY" (p.3), and "IMPORTANT NOTES" (p.4). These sections provide important information concerning the proper operation of the unit. Additionally, in order to feel assured that you have gained a good grasp of every feature provided by your new unit, owner's manual should be read in its entirety. The manual should be saved and kept on hand as a convenient reference.

Copyright © 1997 ROLAND CORPORATION

All rights reserved. No part of this publication may be reproduced in any form without the written permission of ROLAND CORPORATION.

	CAUTION RISK OF ELECTRIC SHOCK DO NOT OPEN	
ATTENTION RISQUE DE CHOC ELECTRIQUE NE PAS OUVRIIR		
<p>CAUTION: TO REDUCE THE RISK OF ELECTRIC SHOCK, DO NOT REMOVE COVER (OR BACK). NO USER-SERVICEABLE PARTS INSIDE. REFER SERVICING TO QUALIFIED SERVICE PERSONNEL.</p>		



The lightning flash with arrowhead symbol, within an equilateral triangle, is intended to alert the user to the presence of uninsulated "dangerous voltage" within the product's enclosure that may be of sufficient magnitude to constitute a risk of electric shock to persons.



The exclamation point within an equilateral triangle is intended to alert the user to the presence of important operating and maintenance (servicing) instructions in the literature accompanying the product.

INSTRUCTIONS PERTAINING TO A RISK OF FIRE, ELECTRIC SHOCK, OR INJURY TO PERSONS.

IMPORTANT SAFETY INSTRUCTIONS

SAVE THESE INSTRUCTIONS

WARNING - When using electric products, basic precautions should always be followed, including the following:

1. Read all the instructions before using the product.
2. Do not use this product near water — for example, near a bathtub, washbowl, kitchen sink, in a wet basement, or near a swimming pool, or the like.
3. This product should be used only with a cart or stand that is recommended by the manufacturer.
4. This product, either alone or in combination with an amplifier and headphones or speakers, may be capable of producing sound levels that could cause permanent hearing loss. Do not operate for a long period of time at a high volume level or at a level that is uncomfortable. If you experience any hearing loss or ringing in the ears, you should consult an audiologist.
5. The product should be located so that its location or position does not interfere with its proper ventilation.
6. The product should be located away from heat sources such as radiators, heat registers, or other products that produce heat.
7. The product should be connected to a power supply only of the type described in the operating instructions or as marked on the product.
8. The power-supply cord of the product should be unplugged from the outlet when left unused for a long period of time.
9. Care should be taken so that objects do not fall and liquids are not spilled into the enclosure through openings.
10. The product should be serviced by qualified service personnel when:
 - A. The power-supply cord or the plug has been damaged; or
 - B. Objects have fallen, or liquid has been spilled onto the product; or
 - C. The product has been exposed to rain; or
 - D. The product does not appear to operate normally or exhibits a marked change in performance; or
 - E. The product has been dropped, or the enclosure damaged.
11. Do not attempt to service the product beyond that described in the user-maintenance instructions. All other servicing should be referred to qualified service personnel.

For the USA

This product may be equipped with a polarized line plug (one blade wider than the other) . This is a safety feature. If you are unable to insert the plug into the outlet, contact an electrician to replace your obsolete outlet. Do not defeat the safety purpose of the plug.

For Canada

For Polarized Line Plug

CAUTION: TO PREVENT ELECTRIC SHOCK, MATCH WIDE BLADE OF PLUG TO WIDE SLOT, FULLY INSERT.
ATTENTION: POUR ÉVITER LES CHOCs ÉLECTRIQUES, INTRODUIRE LA LAME LA PLUS LARGE DE LA FICHE DANS LA BORNE CORRESPONDANTE DE LA PRISE ET POUSSER JUSQU' AU FOND.

For the U.K.

IMPORTANT: THE WIRES IN THIS MAINS LEAD ARE COLOURED IN ACCORDANCE WITH THE FOLLOWING CODE.

BLUE: NEUTRAL
BROWN: LIVE

As the colours of the wires in the mains lead of this apparatus may not correspond with the coloured markings identifying the terminals in your plug, proceed as follows:
 The wire which is coloured BLUE must be connected to the terminal which is marked with the letter N or coloured BLACK.
 The wire which is coloured BROWN must be connected to the terminal which is marked with the letter L or coloured RED.
 Under no circumstances must either of the above wires be connected to the earth terminal of a three pin plug.



USING THE UNIT SAFELY

INSTRUCTIONS FOR THE PREVENTION OF FIRE, ELECTRIC SHOCK, OR INJURY TO PERSONS

About ⚠ WARNING and ⚠ CAUTION Notices









⚠ WARNING	Used for instructions intended to alert the user to the risk of death or severe injury should the unit be used improperly.
⚠ CAUTION	Used for instructions intended to alert the user to the risk of injury or material damage should the unit be used improperly. * Material damage refers to damage or other adverse effects caused with respect to the home and all its furnishings, as well to domestic animals or pets.

About the Symbols









	The ⚠ symbol alerts the user to important instructions or warnings. The specific meaning of the symbol is determined by the design contained within the triangle. In the case of the symbol at left, it is used for general cautions, warnings, or alerts to danger.
	The ⓧ symbol alerts the user to items that must never be carried out (are forbidden). The specific thing that must not be done is indicated by the design contained within the circle. In the case of the symbol at left, it means that the unit must never be disassembled.
	The ● symbol alerts the user to things that must be carried out. The specific thing that must be done is indicated by the design contained within the circle. In the case of the symbol at left, it means that the power-plug must be unplugged from the outlet.

ALWAYS OBSERVE THE FOLLOWING

⚠ WARNING

- Before using this unit, make sure to read the instructions below, and the Owner's Manual. 
- Do not open or perform any internal modifications on the unit. 
- Make sure you always have the unit placed so it is level and sure to remain stable. Never place it on stands that could wobble, or on inclined surfaces. 
- Avoid damaging the power cord. Do not bend it excessively, step on it, place heavy objects on it, etc. A damaged cord can easily become a shock or fire hazard. Never use a power cord after it has been damaged. 
- In households with small children, an adult should provide supervision until the child is capable of following all the rules essential for the safe operation of the unit. 
- Protect the unit from strong impact. (Do not drop it!) 
- Do not force the unit's power-supply cord to share an outlet with an unreasonable number of other devices. Be especially careful when using extension cords—the total power used by all devices you have connected to the extension cord's outlet must never exceed the power rating (watts/amperes) for the extension cord. Excessive loads can cause the insulation on the cord to heat up and eventually melt through. 
- Before using the unit in a foreign country, consult with your retailer, the nearest Roland Service Center, or an authorized Roland distributor, as listed on the "Information" page. 

⚠ CAUTION

- Always grasp only the plug on the power-supply cord when plugging into, or unplugging from, an outlet or this unit. 
- Try to prevent cords and cables from becoming entangled. Also, all cords and cables should be placed so they are out of the reach of children. 
- Never climb on top of, nor place heavy objects on the unit. 
- Never handle the power cord or its plugs with wet hands when plugging into, or unplugging from, an outlet or this unit. 
- If you need to move the instrument, take note of the precautions listed below. At least two persons are required to safely lift and move the unit. It should be handled carefully, all the while keeping it level. Make sure to have a firm grip, to protect yourself from injury and the instrument from damage. 
- Check to make sure the screw securing the unit to the stand have not become loose. Fasten them again securely whenever you notice any loosening.
- Disconnect the power cord.
- Disconnect all cords coming from external devices.
- Raise the adjusters on the stand.
- Close the lid.
- Fold down the music stand.
- Before cleaning the unit, turn off the power and unplug the power cord from the outlet (p.14). 
- Whenever you suspect the possibility of lightning in your area, pull the plug on the power cord out of the outlet. 
- Be careful when opening/closing the lid so you do not get your fingers pinched (p.12). Adult supervision is recommended whenever small children use the unit. 

Important Notes

In addition to the items listed under "IMPORTANT SAFETY INSTRUCTIONS" and "USING THE UNIT SAFELY" on pages 2 and 3, please read and observe the following:

Power Supply -----

- Do not use this unit on the same power circuit with any device that will generate line noise (such as an electric motor or variable lighting system).
- Before connecting this unit to other devices, turn off the power to all units. This will help prevent malfunctions and/or damage to speakers or other devices.

Placement -----

- Using the unit near power amplifiers (or other equipment containing large power transformers) may induce hum. To alleviate the problem, change the orientation of this unit; or move it farther away from the source of interference.
- This device may interfere with radio and television reception. Do not use this device in the vicinity of such receivers.
- Do not expose the unit to direct sunlight, place it near devices that radiate heat, leave it inside an enclosed vehicle, or otherwise subject it to temperature extremes. Excessive heat can deform or discolor the unit.

Maintenance -----

- For everyday cleaning wipe the unit with a soft, dry cloth or one that has been slightly dampened with water. To remove stubborn dirt, use a cloth impregnated with a mild, non-abrasive detergent. Afterwards, be sure to wipe the unit thoroughly with a soft, dry cloth.
- Never use benzine, thinners, alcohol or solvents of any kind, to avoid the possibility of discoloration and/or deformation.

Additional Precautions -----

- Use a reasonable amount of care when using the unit's buttons, sliders, or other controls; and when using its jacks and connectors. Rough handling can lead to malfunctions.
- Never strike or apply strong pressure to the display.
- When connecting / disconnecting all cables, grasp the connector itself—never pull on the cable. This way you will avoid causing shorts, or damage to the cable's internal elements.
- A small amount of heat will radiate from the unit during normal operation.
- To avoid disturbing your neighbors, try to keep the unit's volume at reasonable levels. You may prefer to use headphones, so you do not need to be concerned about those around you (especially when it is late at night).
- When you need to transport the unit, package it in the box (including padding) that it came in, if possible. Otherwise, you will need to use equivalent packaging materials.
- Do not pull the music stand too far forward when setting/releasing its latches.

* GS () is a registered trademark of Roland Corporation.

* Apple is a registered trademark of Apple Computer, Inc.

* Macintosh is a registered trademark of Apple Computer, Inc.

* IBM PC is a registered trademark of International Business Machines Corporation.

Contents

Using the Unit Safely	3
Important Notes	4
Starting Out	7
Main Features	7
Button Descriptions	8
About the Display Screen	10
Before You Play	12
Opening and Closing the Cover	12
Setting Up the Music Stand	12
About the Pedals	12
Connecting Headphones	13
Connecting a Microphone	13
Turning the Power On and Off	14
Playing the Keyboard	15
Adjusting Sound Volume and Brightness	15
Listening to Continuous Repeated Playback of All Songs— All Song Play	15
Performing with Various Instrument Sounds	16
Layering Two Instrument Sounds— Dual Play	17
Changing the Sounds Played by the	
Left and Right Hands of the Keyboard— The “Split” Function	18
Playing Along with the Auto-Accompaniment— The “Pianist” Function	20
Changing to Easy Key Signatures— The “Key Transpose” Function	22
Adding Breadth to the Sound— Chorus Effect	24
Adding Reverberation to the Sound— Reverb Effect	24
Sounding the Metronome	25
Adjusting Keyboard Touch Sensitivity	27
Practicing a Song	28
Listening to One Song— Playback/Stop	28
Changing the Tempo to One That’s Easy to Practice	29
Playing Songs Without Tempo Changes— Tempo Mute	30
Synchronizing the Timing When You Start to Play— Count In	30
Practicing Along with Songs	31
Right-Hand Exercise	31
Left-Hand Exercise	32
Playing With Both Hands to Accompaniment— Minus One Play	32
Try Recording	33
Recording with Songs	33
Recording New Songs	36
Deleting Sound From Recorded Tracks	39
Deleting Recorded Songs	39

Other Functions40

Disabling All Buttons— Panel Lock40
Changing the Key When Playing Back Songs40
Playing Songs Using Tunings from Classical Music40
Adjusting the Standard Pitch42
Selecting Tuning Curves42

Changing Various Settings43

Changing the Pedal Operations43
Changing the Depth of the Chorus Effect43
Changing the Depth of the Reverb Effect44
Changing the Damper Pedal’s Resonance44
Changing the Keyboard’s Split Point45
Changing the Volume Balance in Dual Play45
Changing the Volume Balance Between the Song and the Keyboard46
Changing the Metronome Volume46
Changing the Metronome Settings (HP 535)47
Disabling the Beat Indicator’s Pulsations48
Turning off the Bouncing Ball (HP 535)48
Switching the Language on the Display Screen (HP 535)48

Connecting External Devices49

Connection Jacks—Names and Functions49
Making Connections49
Using MIDI51

Appendices53

Troubleshooting53
Error Messages54
List of Tone Names55
List of Styles59
List of Ways to Play Chords60
List of Song Titles62
List of Extended Functions63
Specifications64
Glossary of Terms Used in This Manual66
Index67
MIDI Implementation Chart68

Main Features

● Authentic Piano Performances

With the Roland HP 535/335, you can enjoy realistic piano performances with high-quality concert grand piano tone and authentic hammer action keyboard.

● Over 200 Different Instrument Sounds Built In

While of course providing great piano sounds, the HP 335 also gives you over 200 other instrument sounds, so you can get just the right sound for songs in a wide variety of musical genres. (p.16)

● Equipped with useful functions for piano practice

Numerous useful built-in functions for piano practice—recording functions that you can operate like a tape recorder (p.33), 25 songs that feature rich piano sounds, playback of one hand at a time, and more—let you practice piano as is possible only with an electronic piano (p.31). Additionally, a bouncing ball (HP 535) bounces in time with the music in the display, allows you to grasp the tempo spatially, rather than the normal way of trying to comprehend rhythm as a series of dots.

● Built-In Automatic Accompaniment Function

The HP 535/335 comes with the “Pianist Function,” automatic piano accompaniment for easy fingering in a wide variety of musical genres (p.20).

■ About the HP 535/335 Sound Generator

The HP 535/335 come equipped with GM/GS sound generators.



General GM System

The General MIDI system is a set of recommendations which seeks to provide a way to go beyond the limitations of proprietary designs, and standardize the MIDI capabilities of sound generating devices. Sound generating devices and music data that meets the General MIDI standard bears the General MIDI logo (). Music data bearing the General MIDI logo can be played back using any General MIDI sound generating unit to produce essentially the same musical performance.



GS format

The GS Format is Roland's set of specifications for standardizing the performance of sound generating devices. In addition to including support for everything defined by the General MIDI System, the highly-compatible GS Format additionally offers an expanded number of sounds, provides for the editing of sounds, and spells out many details for a wide range of extra features, including effects such as reverb and chorus.

Designed with the future in mind, the GS Format can readily include new sounds and support new hardware features when they arrive.

Since it is upwardly compatible with the General MIDI System, Roland's GS Format is capable of reliably playing back GM Scores equally as well as it performs GS Music Data (music data that has been created with the GS Format in mind).

This product supports both the General MIDI system and the GS format, and can be used to play back music data carrying either of these logos.

Starting Out

Button Descriptions

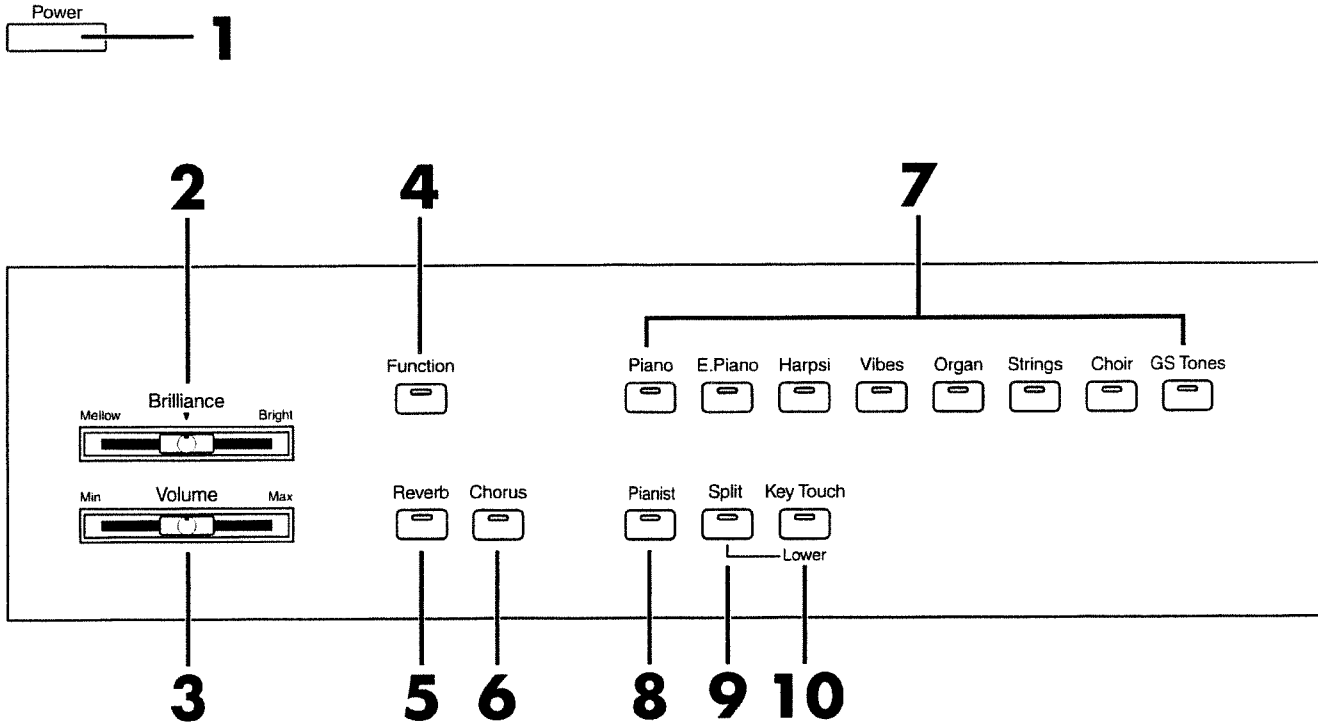
**1 [Power] Switch**

Turns the HP 535/335's power on and off (p.14).

2 [Brilliance] Slider

Adjusts the tone brightness (p.15).

3 [Volume] Slider

Adjusts the overall volume level (p.15)

4 [Function] Button

Pressing this button before pressing other buttons on the keyboard calls up alternate functions for those buttons. See the "List of Extended Functions" (p.63).

5 [Reverb] Button

Pressing this button adds reverberation to the sound (p.24).

6 [Chorus] Button

Pressing this button adds the chorus effect to the sound (p.24).

7 [Tone] Buttons

Use these buttons to select the tone type to be played on the keyboard (p.16).

Tones are grouped into the following eight types, indicated by their respective tone group name button.

[Piano]
[E.Piano]
[Harpsi]
[Vibes]
[Organ]
[Strings]
[Choir]
[GS Tones]

8 [Pianist] Button

By pressing this button, you can have the automatic piano accompaniment play along while you perform (p.20).

9 [Split] Button

Pressing this button divides the keyboard into right and left zones. Then, different sounds can be played in each zone (p.18).

When the "automatic accompaniment" function is in use, the accompaniment for the intro can also be turned on and off. (p.21)



In this manual, descriptions apply to HP 535.

Please note that are certain differences between the HP 535 and the HP 335.

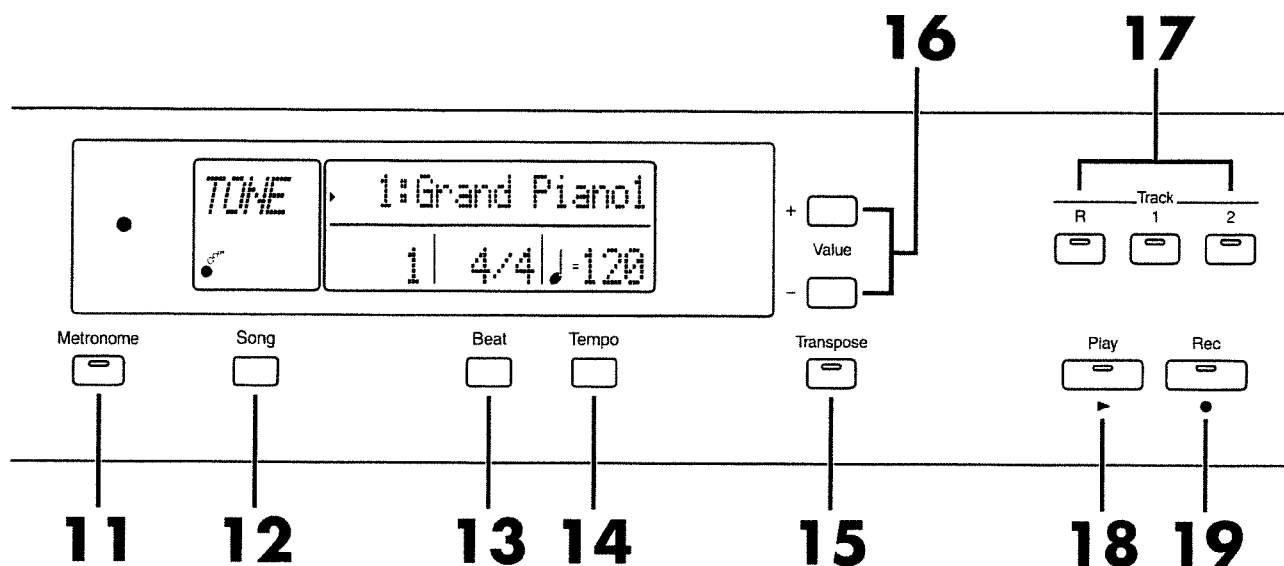

10 [Key Touch] Button

This is used for adjusting the “touch,” or response of the keys when you play the keyboard (p.27).

When the keyboard is in Split mode, this button is used to change the tone of the Lower part (p.19).

When you are using the automatic accompaniment function, this can start or stop the playback (p.21).

11 [Metronome] Button

Pressed to turn on the HP 535/335’s built-in metronome (p.25).

12 [Song] Button

For selecting internal songs (p.28).

13 [Beat] Button

Press this button to change the beat (p.25).

14 [Tempo] Button

Press this button to adjust the tempo (p.26, 29).

15 [Transpose] Button

Pressing this button transposes the keyboard (p.22).

16 Value [+/-] Buttons

The two Value buttons, [+] and [-], are used to adjust the values of a variety of settings.

Pressing both the [+] and [-] buttons simultaneously returns the settings of each particular item or function to its original values.

17 [Track] Buttons

There are three Track buttons, [R], [1], and [2] corresponding to the three tracks to which recorded sounds are assigned. The buttons are used when playing back each instrument’s part in a song and when routing sounds to tracks when recording.

18 [Play] Button

This button starts and stops playback or recording of songs.

For playback, see (p.28); for recording see (p.33).

19 [Rec] Button

Pressing this button puts the keyboard in and out of record standby mode (p.33).

Starting Out

About the Display Screen

The HP 535's Basic Screen

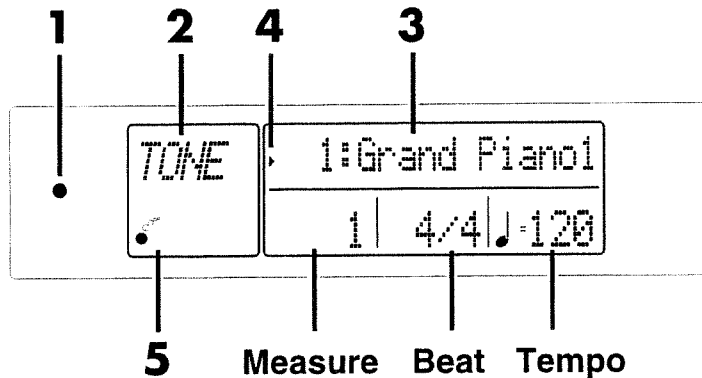
**1 Beat Indicator**

This flashes in time with the beat of the song or metronome.



If desired, you can stop the Beat Indicator from flashing. Please refer to "Disabling the Beat Indicator's Pulsations" on (p.48).

2 Items for Which You Can Make Settings

It sometimes indicates [SONG], [TOUCH], [UPPER], [LOWER], or [STYLE] instead. When the unit is switched on, it defaults to [TONE].

3 Contents of Items You Can Set

For example, when "Song" appears in two display positions, the format "Song Number:Song Name," such as in "1:SalutD' Amour," is displayed.

4 Cursor

The value of the item at the position of the cursor can be changed by pressing the Value [+] and [-] buttons.

For example, when you press the [Tempo] button, the cursor moves to where Tempo appears in the display, at which point you can change the value of the tempo.

5 Bouncing Ball

The bouncing ball is a flashing dot that moves across the screen in time with the music or the metronome. Because the ball traces a semicircular path as it moves, you can grasp rhythm as a spatial concept, rather than just as points.



If so desired, you can stop the Bouncing Ball from being displayed. Please refer to "Turning off the Bouncing Ball" on p.48.

The HP 335's Basic Screen

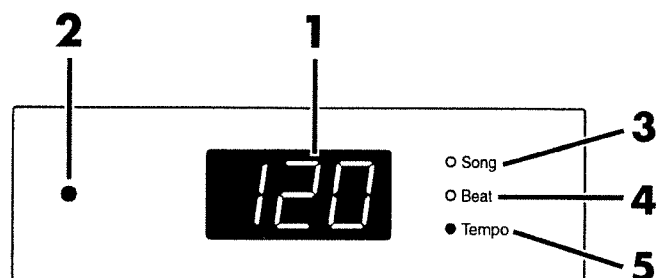

1 Tempo, Beat, Song Name, Song Type Settings Values

2 Beat Indicator

Flashes in time with the beat of the song or metronome.



If so desired, you can stop the Beat Indicator from flashing. Please refer to "Disabling the Beat Indicator's Pulsations" on p.48.

3 Indicator (Song)

You can change songs only when this indicator is lit. The song number appears in the display.

4 Indicator (Beat)

You can change the beat only when this indicator is lit. The beat appears in the display.

5 Indicator (Tempo)

You can change the tempo only when this indicator is lit. The tempo appears in the display.

Before You Play

Before You Play

Opening and Closing the Cover

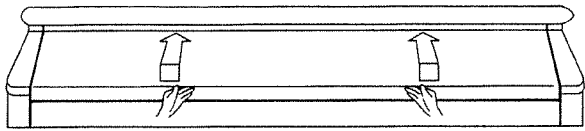

1. When opening the HP 535/335's cover, grasp the cover with both hands and gently lift it upwards, then slide it towards the back of the piano.
2. When closing the cover, slowly pull the cover forward, then gently lower it into place.

NOTE

Take care not to allow fingers to be caught or pinched when opening and closing the cover. Make sure an adult is on hand to provide assistance when young children are playing the HP 535/335.

For safety, transport the keyboard only with the cover in the closed position.

Setting Up the Music Stand

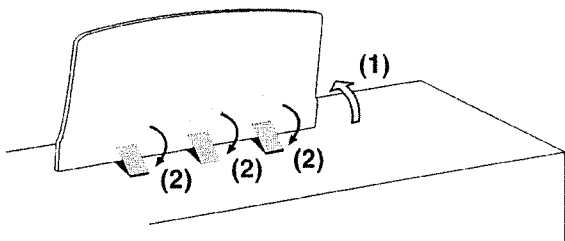

1. Gently raise the music stand and set it as illustrated.
2. To collapse the stand, fold in the metal fittings while supporting the stand with both hands and gently fold down the stand.

About the Pedals

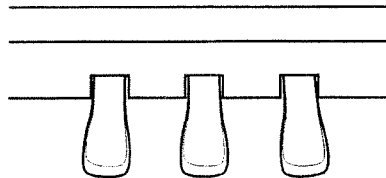

Soft Pedal
Sostenuto Pedal
Damper Pedal

Soft Pedal

This pedal softens the sound.

Playing with the soft pedal depressed produces a sound that is not as strong as when otherwise played with the equivalent strength. The degree of softness varies subtly with the amount the pedal is pressed.

Sostenuto Pedal

With the sostenuto pedal, only the sound played at the moment the pedal is pressed is sustained.

Damper Pedal

Use this pedal when you want the sound to linger.

While the damper pedal is depressed, the sound from the keyboard continues to linger/remain for an extended period, even when you remove your fingers from the keys. The length of time that the sound continues varies subtly with the amount the pedal is pressed.

MEMO

You can change the amount of resonance applied with the damper pedal. For more information and instructions, please refer to "Changing the Damper Pedal's Resonance" (p.44).

MEMO

You can assign other functions to the sostenuto pedal. For more information and instructions, please refer to "Changing the Pedal Operations" (p.43).

Connecting Headphones

The HP 535/335 feature two headphone jacks. This allows two people to listen through headphones simultaneously, making it very useful for lessons and when performing piano pieces for four hands. Additionally, this allows you to play without having to worry about bothering others around you, even at night.

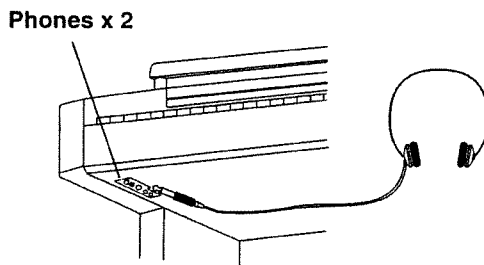

1. Connect the headphones to either of the headphone jacks (Phones) on the underside of the HP 535/335, on the left.

Sound will no longer be heard from the HP-535's speakers. Sound will be heard only through the headphones.

2. Adjust the headphone volume with the HP 535/335's main [Volume] slider.



Please use Roland's RH-80/120 series of stereo headphones (sold separately), or similar stereo headphones. Consult your Roland dealer when purchasing a headphones for use with the HP 535/335.

● Precautions to Take When Using Headphones

- To avoid damaging or severing the headphone cord, be sure to handle the headphones by holding the phones themselves, and grasping the plug and not the cord when pulling the headphone plug.
- Connecting the headphones when the volume of connected equipment is turned up may result in damage to the headphones. Connect the headphones only after turning the volume down completely.
- Listening at excessively high volume levels will not only damage the headphones, but may also cause hearing loss. Listen at appropriate levels.

Connecting a Microphone

The HP 535/335 features a microphone jack, allowing you connect a microphone and enjoy singing, even to your own accompaniment. Enjoy a wide variety of possibilities with a mike at the ready.

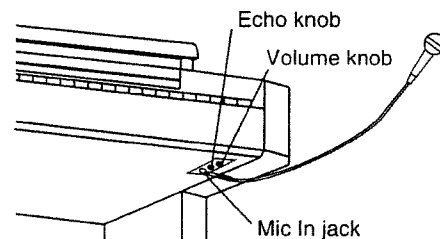

1. Connect the microphone to either of the [Mic In] jacks on the HP 535/335's lower right panel.
2. Adjust the microphone volume with the [Volume] knob, next to the [Echo] Knob.
3. When using echo with the sound, adjust the amount of echo effect with the [Echo] knob next to the [Mic In] jack.



You can use one of Roland's DR-10/20 series microphones (sold separately), or a similar microphone. Consult your Roland dealer when purchasing a mike for use with the HP 535/335.

● Precautions to Take When Using A Microphone

- Be careful of high volume levels when using mikes late at night or early in the morning.
- Turn down the volume when connecting the microphone. Connecting a mike while the volume is turned up may result in noise from your speakers.
- Howling could be produced depending on the location of microphones relative to speakers. This can be remedied by:
 1. Changing the orientation of the microphone.
 2. Relocating microphone at a greater distance from speakers.
 3. Lowering volume levels.

Before You Play

Turning the Power On and Off

Be sure to follow the procedure below when turning on and off the power. Failure to follow these steps in the order given may result in malfunction, and/or damage to speakers or other equipment.

■ Turning On the Power

1. Before switching the power on, turn the volume all the way down (using the slider to the left).

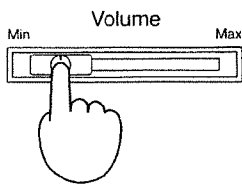

2. Connect the power cord that came with your HP 535/335 to the AC Inlet socket on the bottom of the unit.
3. Plug the other end of the power cord into a wall outlet.

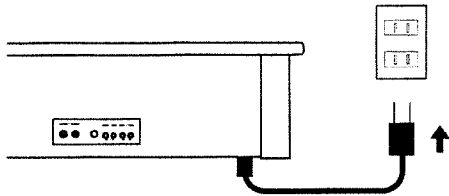

4. Press the [Power] switch.
Several seconds after the power is turned on, the keyboard will produce sound when played.

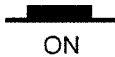

MEMO

This unit is equipped with a protection circuit. A brief interval (a few seconds) after power up is required before the unit will operate normally.

Use only the power cord that is provided with your HP 535/335.

■ Turning Off the Power

1. Before switching the power off, turn the volume all the way down (using the slider to the left).
2. Press the [Power] switch.
The power is turned off.



Playing the Keyboard

Adjusting Sound Volume and Brightness

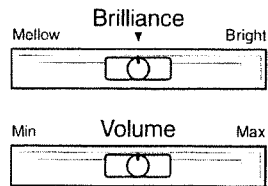

- 1. Overall volume is adjusted with the [Volume] slider.**
Moving the slider to the right increases the volume; moving it to the left decreases the volume.
- 2. Overall tone brightness is adjusted with the [Brilliance] slider.**
Moving the slider to the right make the tone brighter; moving it to the left gives the sound a more muted tone.

Listening to Continuous Repeated Playback of All Songs— All Song Play

The HP 535/335 features 25 internal piano songs. Listening to all of these songs repeatedly played back in sequence is known as “All Song Play.”

For the titles of the internal songs and their composers, please refer to the “List of Song Titles” (p.62).

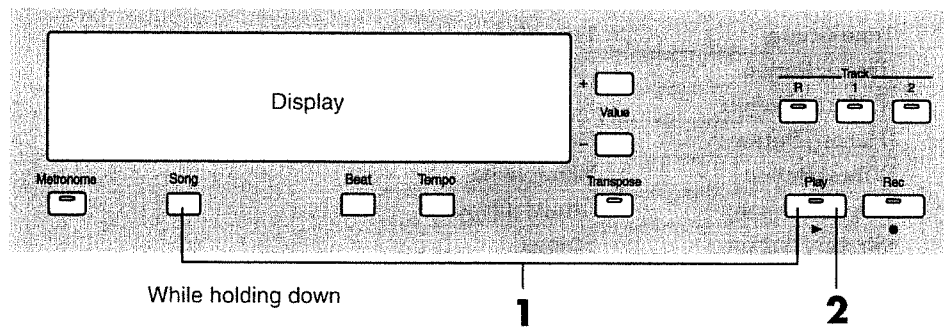

- 1. While pressing the [Song] button, press [Play] button.**
Playback begins with the selected song. When the last song has finished playing, playback then repeats after returning to the first song.
- 2. When you press the [Play] button once more, playback then stops.**



With the internal songs, you can also select one song at a time for playback. Please refer to “Listening to One Song— Playback/Stop” (p.28).

Performing with Various Instrument Sounds

The HP 535/335 features over 200 different internal musical instrument sounds and sound effects. Enjoy performing with this superb collection of sounds, designed to accommodate almost any imaginable musical genre.

These internal sounds are called "tones." The tones are divided into eight separate groups, each assigned to one of the eight "Tone Group" buttons.

When the HP 535/335 is turned off, the tone is reset to "Grand Piano 1."

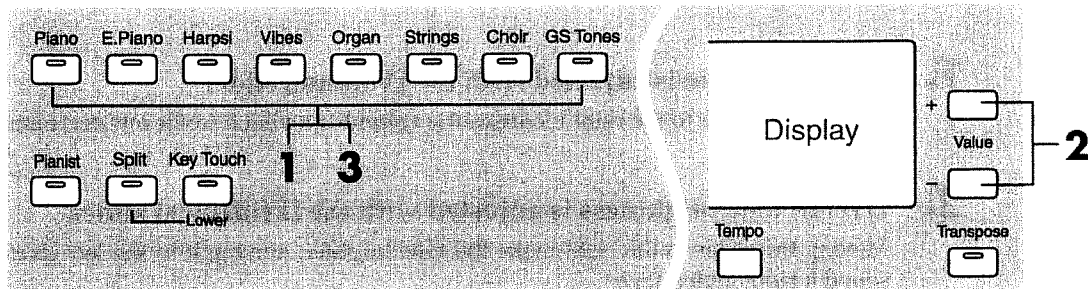

1. Press any [Tone] button.

Tone 1 in each of the Tone groups will sound. Go ahead and play the keyboard to hear these tones.

- When you turn on the power to the keyboard, the following tones are set to play.

Tone Group	Tone Name
[Piano] Button	Grand Piano 1
[E.Piano] Button	E. Piano 1
[Harpsi] Button	Harpsichord 1
[Vibes] Button	Vibraphone
[Organ] Button	Church Organ
[Strings] Button	Strings
[Choir] Button	Choir
[GS Tones] Button	Fantasia

2. Use the Value [+] and [-] buttons to select a tone from within a tone group.

The [Tone] buttons flash on and off.

3. Play the keyboard, or press the [Tone] button that is flashing.

When you play the keyboard, the selected tone is played. Press the [Tone] button, and the sound of that tone can be heard.

The [Tone] button's indicator stops flashing and changes to a constant light.



For more about tone names, please refer to the "List of Tone Names" (p.55).

Layering Two Instrument Sounds— Dual Play

Playing with two different tones on the keyboard simultaneously is called “Dual Play.”

As an example, try layering the Grand Piano and Strings tones.

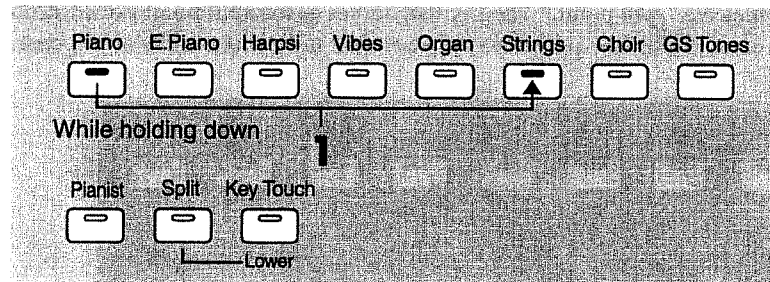

- 1.** While pressing the [Piano] button, also press the [Strings] button.
Both button indicators go on.
Try playing the keyboard. The sound features both the Grand Piano 1 and Strings tones playing simultaneously.
Pressing one [Tone] button while simultaneously pressing another [Tone] button puts the keyboard in Dual Play mode.
- **To Change the Tone of the Right Button of the Two Selected Tones in Dual Play**
 - 1.** Use the Value [+] and [-] buttons to find and select a tone.
The right [Tone] button's indicator flashes.
 - 2.** Either play the keyboard or press the flashing [Tone] button.
Dual Play now features the tone of the left side's tone button along with the newly selected tone.
The [Tone] button's indicator stops flashing, and lights steadily.
 - **To Change the Tone of the Left Button of the Two Selected Tones in Dual Play**
Once you have cancelled Dual Play, reselect the tones you want to use.
 - **Cancelling Dual Play**
When the [Tone] button is pressed in Dual Play, only the tone of the button that is pressed continues to sound.



You can adjust the volume balance between the two selected tones in Dual Play. Please refer to "Changing the Volume Balance in Dual Play" (p.45).

Changing the Sounds Played by the Left and Right Hands of the Keyboard — The “Split” Function

The Split feature allows you to split the keyboard into two zones, then play a different sound in each zone. This division of the keyboard into upper and lower zones is referred to as “split,” and the particular key on the keyboard where the split occurs is known as the “split point.” The key that serves as the split point is included in the left-hand zone. Each time power to the keyboard is turned on, the split point is reset to “F#3.”

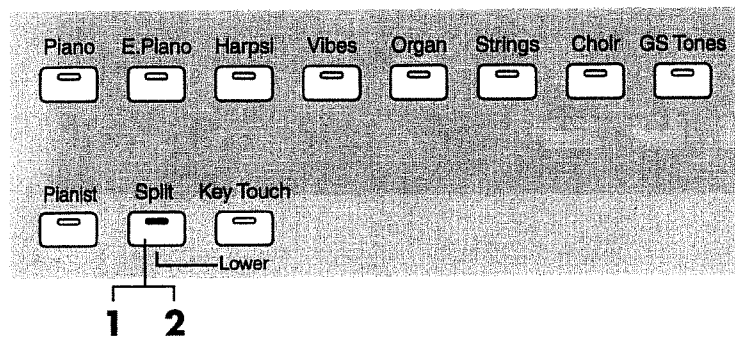

1. Press the [Split] button.

The [Split] button's indicator lights up, and the keyboard is divided into upper and lower zones.

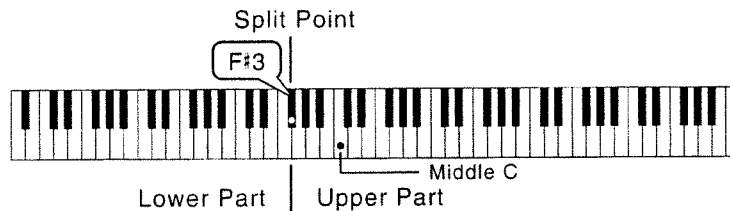

The tone in the right-hand part remains the same as it was before the keyboard was split, and the tone in the lower part switches to “Acoustic Bs.”

2. Pressing the [Split] button once more cancels the split function.

The [Split] button's indicator then goes out. The tone in the upper part then is effective for the entire keyboard.

When you switch to Split mode directly from Dual Play, the two tones played in Dual Play become the tone of the right hand of the keyboard in Split mode.

● Changing Tone Played by the Right Hand

You can select the upper tone in the same manner as you do when selecting tones normally.



Please refer to “Performing with Various Instrument Sounds” (p.16).

● Changing Tone Played by the Left Hand

- 1. Press the [Key Touch] button.**
The [Key Touch] button and the lower [Tone] button's indicator light up.
- 2. To select a Tone in a different Tone Group, press any [Tone] button.**
- 3. Use the Value [+] and [-] buttons to find and select a tone.**
The [Tone] button's indicator flashes.
- 4. Either play the keyboard or press the flashing [Tone] button.**
The [Tone] button stops flashing, staying constantly lit, and the selected tone is sounded in the left hand.
The tone is set to "Acoustic Bs" for lower part when the keyboard is turned on.
- 5. When the [Key Touch] button is pressed once more, the keyboard tone reverts to that of the upper part.**
The [Key Touch] button's indicator goes out.



Pressing one of the keys on the keyboard while pressing the [Split] button changes the location of the split point. Please refer to "Changing the Keyboard's Split Point" (p.45).



While in Split mode, the damper pedal affects only the upper part of the keyboard. If you want to add reverberation effects to the lower part as well, please refer to "Changing the Pedal Operations" (p.43).

Playing Along with the Auto-Accompaniment — The “Pianist” Function

The “Pianist Function” provides automatic piano accompaniment for a variety of musical genres, but with easy fingering.

“Styles” are musical patterns that provide accompaniment for almost any kind of music.



For more information on styles, please refer to “List of Styles” (p.59).



With the “Pianist Function,” it is not necessary to correctly press all of the keys in a chord for accompaniment. You can activate the accompaniment just by pressing one or two representative keys of each chord.

To see which keys sound what chords, please refer to “List of Ways to Play Chords” (p.60).

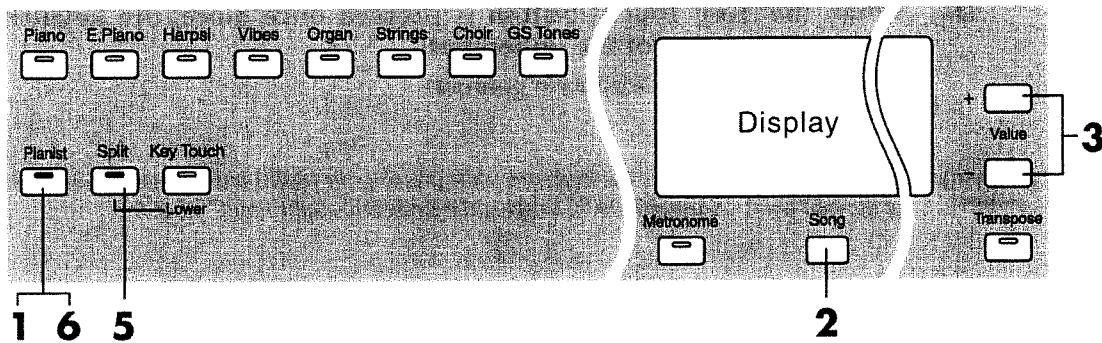

1. Press the [Pianist] button.

The keyboard is split into chord recognition and upper parts.

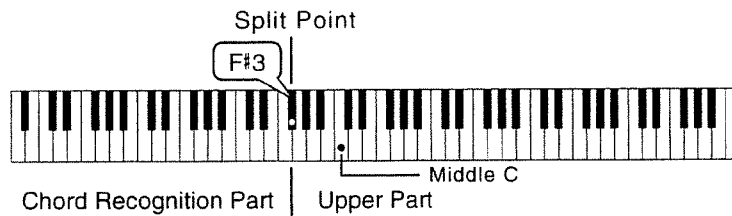

2. Press the [Song] button.

3. Using the Value [+] and [-] buttons, find and select a style.

4. Press one of the keys in the area of the chord recognition side for the chord you want to play.

The accompaniment start with the intro being played.
You can play the melody in the right hand.

5. When you press the [Split] button, the ending is played, and the accompaniment ceases.

If you press the [Key Touch] button while a song is in progress, the accompaniment stops without the ending being played.

Press the [Key Touch] button again, and the unit starts playing the accompaniment.

6. If you press the [Pianist] button once again, the button's indicator goes out, and the Pianist function is cancelled.

If you press the [Pianist] button while a song is progress, the accompaniment stop without the ending being played, the Pianist function is canceled.



*The beat for the accompaniment cannot be changed.
When Key Transpose is in effect (p.22), the automatic accompaniment is also transposed.*



*You can change the balance between the keyboard volume and the volume of the accompaniment.
Please refer to "Changing the Volume Balance Between the Song and the Keyboard" (p. 46).*

● **Playing/Starting With No Intro**

You can omit the intro portion from the performance of automatic accompaniment.

- Press the [Split] button until the button's indicator is off, and the intro is set not to be played.
- Press the [Split] button until the button's indicator is flashing, and the intro is then set to be played.

Changing to Easy Key Signatures — The “Key Transpose” Function

You can play in a different key—without changing the keys you are playing. For example, to play a song in C major even though it was actually written in E major, or to play songs with difficult key signatures full of sharps or flats, you can simply change to a key that is easier for you to play.

Key transpositions remain in effect until the keyboard’s power is turned off.

■ Example: Playing an E major song in C major

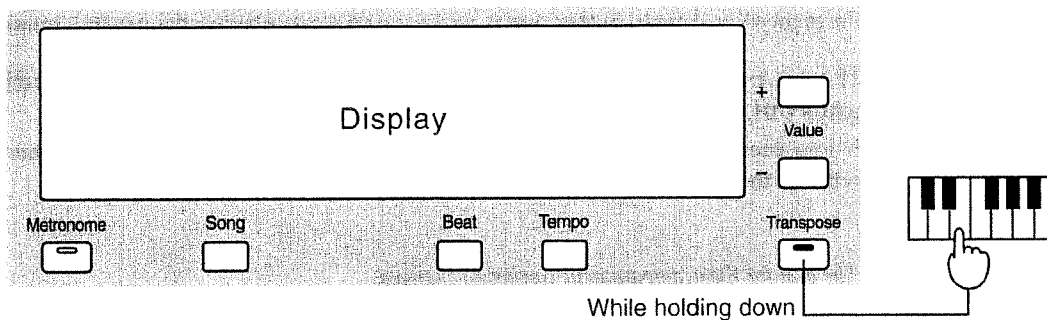

1. While holding the [transpose] button down, press the key that corresponds to the main note of the pitch you wish to transpose to.

For example, press the major third of C Major (E). The [Transpose] button’s indicator will be lit, then the key is transposed.

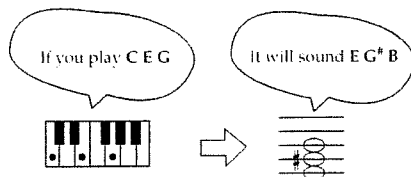

2. Pressing the [Transpose] button once more to make the [Transpose] button’s indicator dark. The keyboard returns to its original key.

At this point, the transposition setting has not been cancelled. By again pressing the [Transpose] button, the button’s indicator will be lit again, and the set transposition will be produced.



With the Key Transpose function, only the sound of the keys that you play are transposed. If you want to transpose and play back the keyboard’s internal songs, please refer to “Changing the Key When Playing Back Songs” (p.40).

■ Other Method of Transposition

● Method 1

1. While pressing the [Transpose] button, select the degree of transposition using the Value [+] and [-] buttons.

The [Transpose] button's indicator comes on, and the keyboard undergoes the desired transposition.

Each press of the [+] and [-] buttons raises or lowers the key by one half-step (semitone). The values can be set in a range from -6 to 0 to +5.

The [Transpose] button's indicator goes off when the value is "0."

Here, we will consider the C of C Major as our basis. Counting from the tonic to the major third of C (E), there are four keys, including the black keys, so set the value to "+4."

<HP-535>

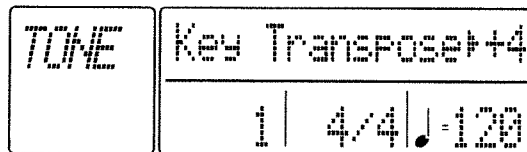

<HP-335>



● Method 2

1. Press the [Function] button.
The [Function] button's indicator comes on.
2. Press the [Transpose] button.
3. Select the value for the transposition with the Value [+] and [-] buttons.

The key is then transposed.

4. Press the [Function] button.

The [Function] button's indicator goes off.

Adding Breadth to the Sound— Chorus Effect

The HP 535/335 allows you to add chorus to what you play on the keyboard. By adding the chorus effect, you can give the sound greater dimension, with more fatness and breadth.

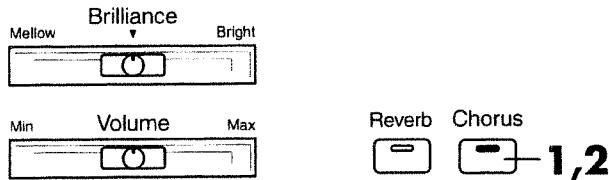

1. Press the [Chorus] button, and confirm that its indicator has lighted. The chorus effect is applied to the currently selected tone.
2. Pressing the [Chorus] button once more turns off the button's indicator and cancels the chorus effect.



You cannot add chorus to individual tones in the [GS Tones] button tone group. You can, however, add and remove chorus to the [GS Tones] button tone group as a whole.



The amount of chorus can be changed, with ten levels of adjustment. Please refer to "Changing the Depth of the Chorus Effect" (p.43).

Adding Reverberation to the Sound— Reverb Effect

The HP 535/335 allows you to add reverberation to what you play on the keyboard. With the reverb effect, you can get a pleasant reverberation, making it sound as if you were performing in a concert hall or similar space.

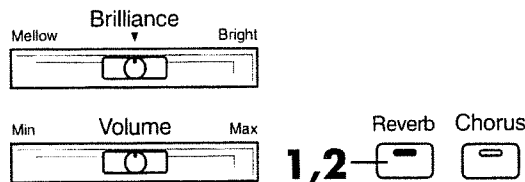

1. Press the [Reverb] button, and confirm that its indicator has lighted. The chorus effect is applied to the entire sound.
2. Pressing the [Reverb] button once more turns off the button's indicator and cancels the reverb effect.



The amount of reverb can be changed, with ten levels of adjustment. Please refer to "Changing the Depth of the Reverb Effect" (p.44).

Sounding the Metronome

The HP 535/335 features a built-in metronome. You can turn the metronome sound on and off with the press of a single button.

When turned on during playback of a song, or during a performance with automatic accompaniment, the metronome sounds to the tempo and beat of the song in progress.

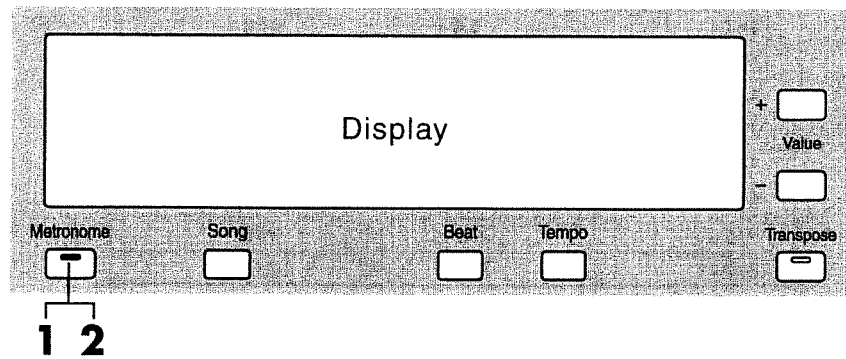

- 1.** Press the [Metronome] button to sound the metronome.
The [Metronome] button's indicator comes on.
- 2.** Press the [Metronome] button once more, and the metronome will stop sounding.
The [Metronome] button's indicator goes out.

● Changing the Beat of the Metronome

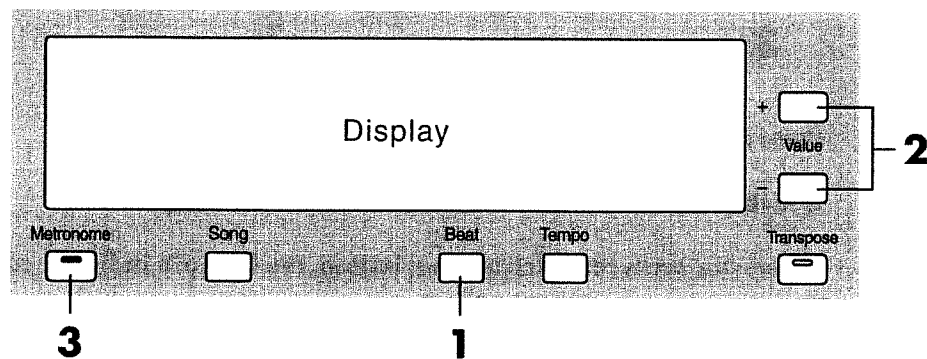

- 1.** Press the [Beat] button.

Playing the Keyboard

- Use the Value [+] and [-] buttons to select the desired beat.

Display (HP 535)	Display (HP 335)	Beat
2/2	2.2	2/2
0/4	0.4	Quiet beats
2/4	2.4	2/4
3/4	3.4	3/4
4/4	4.4	4/4
5/4	5.4	5/4
6/4	6.4	6/4
7/4	7.4	7/4
3/8	3.8	3/8
6/8	6.8	6/8
9/8	9.8	9/8
12/8	12.8	12/8

- Press the [Metronome] button and confirm that its indicator has lighted.
The metronome sounds at the selected beat.

● Changing the Metronome Tempo

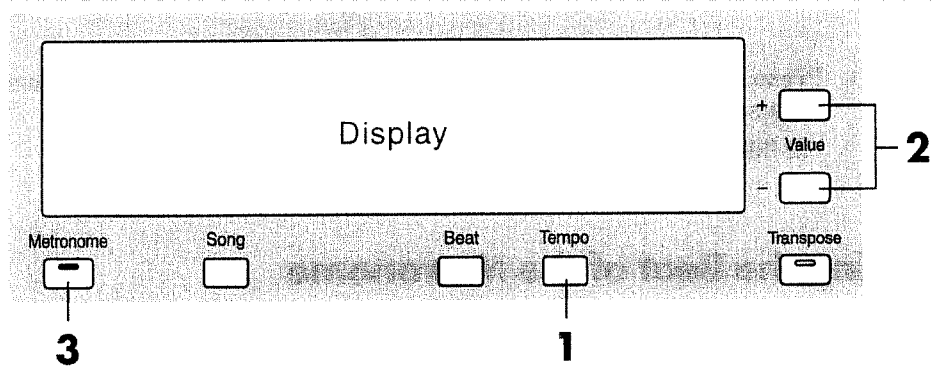

- Press the [Tempo] button.
- Use the Value [+] and [-] buttons to adjust the tempo.
- When you press the [Metronome] button, the button's indicator comes on.
The metronome sounds at the selected tempo.



In addition to the above, the following settings can also be made with respect to the metronome. Please refer to the pages where these settings are explained.

HP 535/335 "Changing the Metronome Volume" (p.46)

HP 535 Only "Changing the Metronome Settings (Changing the Pattern, Changing the Tone)" (p.47)

Adjusting Keyboard Touch Sensitivity

You can change the touch sensitivity, or response of the keys. When the Keyboard is turned on, the response is set to "Medium."

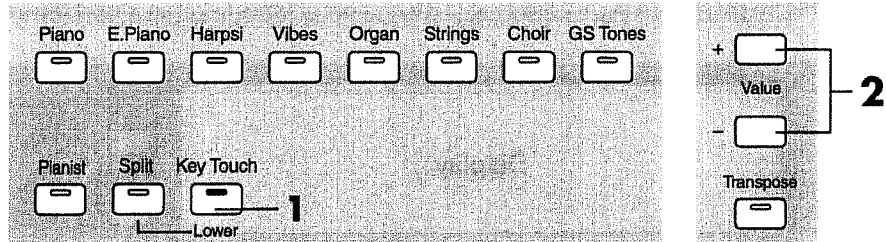

1. Press the [Key Touch] button.
2. Press the value [+] and [-] buttons.

With each press of the button, you select the next one in the series of selections that are available.

Type	Color of Indicator	Meaning
Medium	Off	Normal setting, providing the most natural touch, closest to that of an acoustic piano.
Heavy	Red	With this setting, to play fortissimo the keys must be played much more strongly than normally, as if the keys had become heavier. Adds even more emotion when you play with lots of dynamics. This setting is useful for those with a powerful touch, as well as for those who want to train their fingers.
Light	Green	With this setting, fortissimo can be produced using much less force than normal, thus making the keys seem lighter. This setting makes it easy to play, even for children.
Usr (User)	Orange	This setting is adjustable, with 60 levels of key heaviness.

NOTE The User setting is available only with the model HP 535.

● Obtaining Finer Key Touch Adjustments (HP 535)

1. Press the [Key Touch] button.
2. Press the value [+] and [-] button; "Usr" (User) appears in display.

A bar graph appears on the screen, and now you can change the key touch, with sixty sensitivity levels from which to choose.

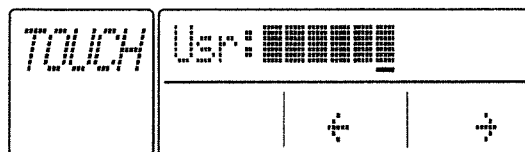

3. Pressing the [Tempo] button gives the keys a heavier touch; pressing the [Beat] button gives them a lighter touch.

With each press of these buttons, the value changes by one. Holding down the button causes the value to change continuously.

Practicing a Song

This section explains useful functions for piano practice on the HP 535/335; we hope that you will try out these in practice as you read the descriptions of these features.

Listening to One Song— Playback/Stop

Before playing a song, try listening to it a number of times to get an idea of the song's feel.

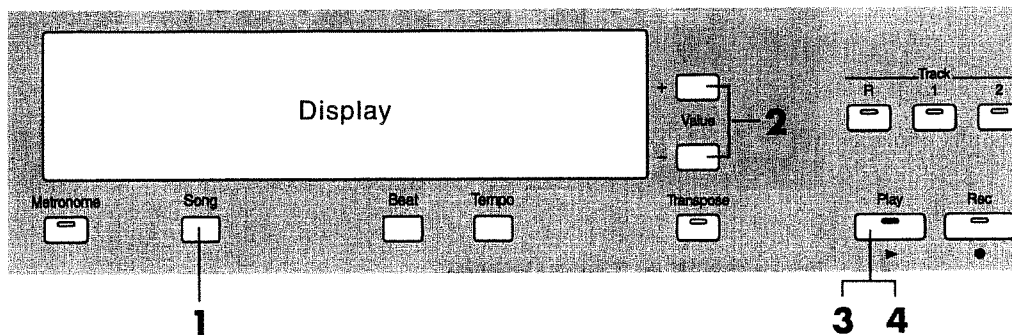

1. Press the [Song] button.
2. Using the Value [+] and [-] buttons, select a song.
The number changes by one each time the button is pressed. Holding down the button causes the numbers to change continuously.
3. Press the [Play] button, and the song starts playing.
4. Pressing the [Play] button once more stops the song.



When songs with pickups (songs that don't start on the first beat) are played back, the measure numbers are indicated in the display as "PU," "1," "2," ...



For the titles of the internal songs and their composers, please refer to the "List of song Titles" (p.62).

Changing the Tempo to One That's Easy to Practice

With songs that are difficult to play because their tempo is too rapid, you may find it helpful to first practice the song with the tempo slowed down. Then, after becoming more familiar with the song, you can practice it at a gradually faster tempo. Changing the tempos has no effect on the pitch.

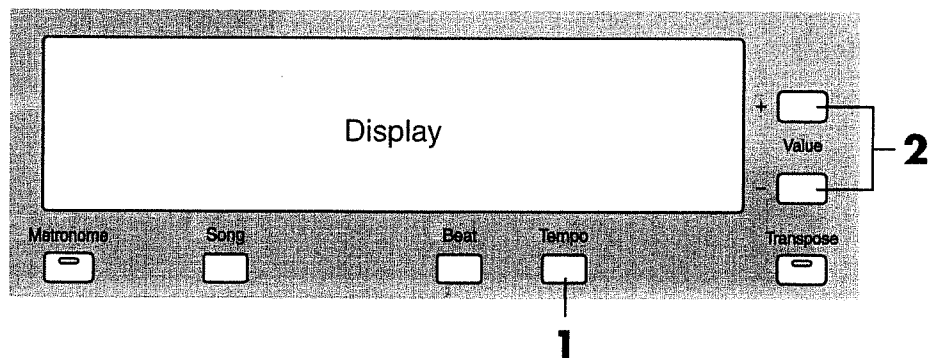

- 1.** Press the [Tempo] button.
- 2.** Adjust the tempo with the Value [+] and [-] buttons.

You can change the tempo even when the song is in progress.

Pressing the [+] button once increases the tempo by one unit. Holding down the button increases the tempo continuously.

Pressing the [-] button once decreases the tempo by one unit. Holding down the button decreases the tempo continuously.

Pressing both the [+] and [-] buttons simultaneously restores the original tempo.

Playing Songs Without Tempo Changes — Tempo Mute

For songs with tempo changes, it can be effective to first practice the song at one fixed tempo. Defeating any tempo changes and playing back the song at one set tempo is called “Tempo Mute.”

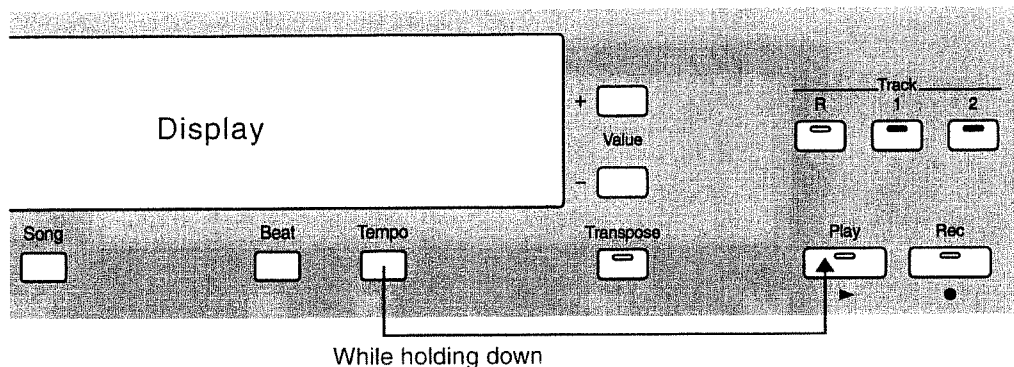

Practicing a Song

1. First, adjust the tempo to one that you prefer (p.29).
2. While pressing the [Tempo] button, press the [Play] button.
The song is set to play at one fixed tempo.
3. Pressing the [Play] button once again while holding down the [Tempo] button undoes the tempo mute.
After you have become able to play the song, try playing it without tempo mute. When you choose a different song, the tempo mute still stays off. When in Tempo Mute, the display shows the following.

<HP-535>

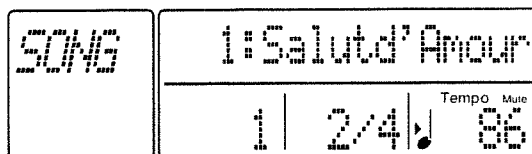

<HP-335>



Synchronizing the Timing When You Start to Play— Count In

At times such as when you want to come in at some point in a song in progress, you can synchronize your timing with that of the song. Sounding a “count sound” leading up to playback of a song is called “Count In.”

On the HP 535/335, if you playback a song while the metronome is sounding, two measures of lead-in count will be heard at the beginning of the song.

Practicing Along with a Song

With the HP 535/335's internal songs, you can have the part of each hand's part played back separately. Playing the internal song's right-hand part with your right hand, and the song's left-hand part with your left hand allow you to practice each hand's part separately.

The internal song is assigned to Track buttons as shown below. The locations to which the sounds are assigned, such as [1], [2], and [R], are known as "tracks."

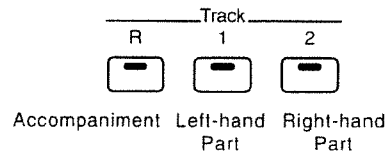

NOTE The Internal piano songs do not have accompaniment. Button indicators for tracks with no sound assigned to them remain unlit.

Right-Hand Exercise

Try deleting the right-hand part so you can practice playing it along with the left-hand part.

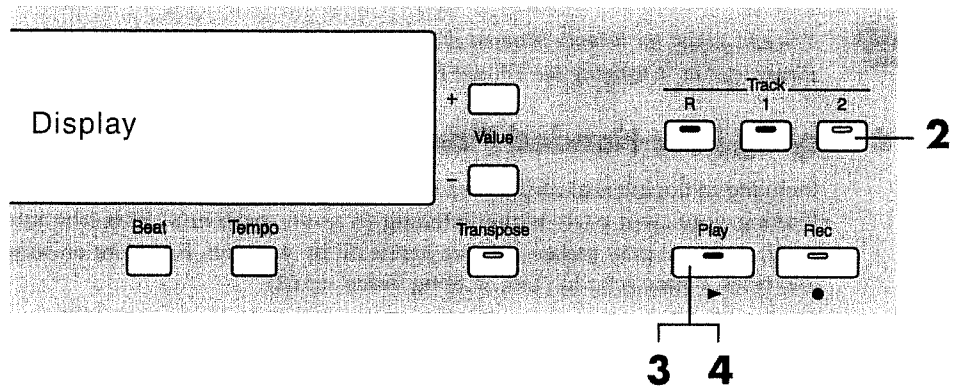

- 1.** Before starting, adjust the tempo and set the metronome.
- 2.** Press the [2] button; the button's indicator goes off.
The right-hand part is now set not to play.

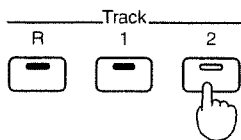

This kind of preventing specified parts of the song from being played is called "muting."

If you press the [2] button once more, the button's indicator lights up, and the mute is cancelled. You can set and cancel mutes even while songs are being played.

Practicing a Song

3. Press the [Play] button to start the song playing.

The right-hand part is not played.

Now you can practice the right-hand part while listening to the left-hand part.

4. Press the [Play] button once more, and the song stops playing.

■ Left-Hand Exercise

In Step 2 of “Right-Hand Exercise,” press the [1] button to turn off its button indicator and mute the left-hand part, and cancel the mute on the right-hand part by pressing the [2] button. Its indicator will then light.

Now, you can practice the left-hand part of the internal song while listening to the right-hand part.

■ Playing With Both Hands to Accompaniment — Minus One Play

After you have practiced each hand’s part separately, try playing the song using both hands.

By selecting an internal song that includes accompaniment, you can play along to the backing provided by the song’s orchestral accompaniment.

Preventing certain instrument parts from playing, and instead performing those parts yourself is known as “Minus One Play.”



You can adjust the balance between the keyboard volume and the volume of the internal song. Please refer to “Changing the Volume Balance Between the Song and the Keyboard” (p.46).

● Playing Four-Handed Piano Pieces

Included in the internal songs are a number of piano pieces for four hands.

Playing your own parts while listening to your “partner’s” part (the internal song itself), lets you play pieces for four hands all by yourself. For more on song numbers and titles, Please refer to “List of Song Titles” (p.62).

For four-handed pieces, assign the parts to the [Track] buttons in the following manner.

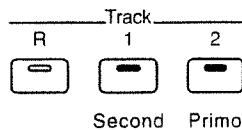

You cannot play the left- and right-hand parts of four-handed pieces separately.

Try Recording



Recorded material is erased when the keyboard is turned off. When you want to save songs you have recorded, it is necessary to connect and record by an external sequencer, such as one in the Roland MT Series, or a similar device. Please refer to "Connecting External Devices" (p.49).

Recording with Songs

Try recording your performance and listening to it a number of times.

■ Recording the Right-Hand Part

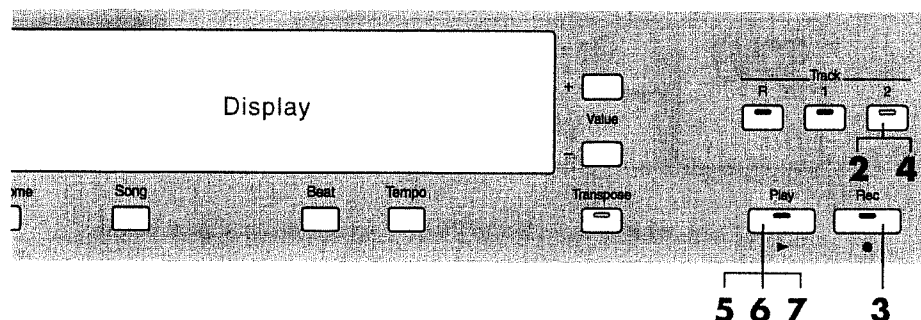

1. Before recording, adjust the tempo and set the metronome.
2. Press the [2] button; the button's indicator goes off.
The right-hand part is now set not to play.

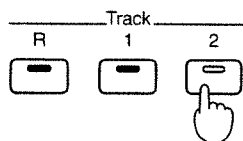

For songs that include accompaniment, if the [R] button's indicator is off, press the button to turn on the indicator.

3. Press the [Rec] button to turn on the indicator.
The keyboard is put in record standby mode.
4. Press the [2] button to make the indicator blink (Note 1).
The right-hand part is now set to be recorded to the [2] button.

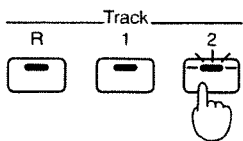

If you want to cancel the recording, then press the [Rec] button once more to make the indicator dark.

Try Recording

5. Press the [Play] button to start recording.

After two measures of a count sound, recording begins.

Play the right-hand part as you listen to the left-hand part being played back.

Recording will also begin if you start playing the keyboard without pressing the [Play] button. In this case, no count sound is played.

6. Press the [Play] button once again, and recording stops.

The song number "0" appears in the display.

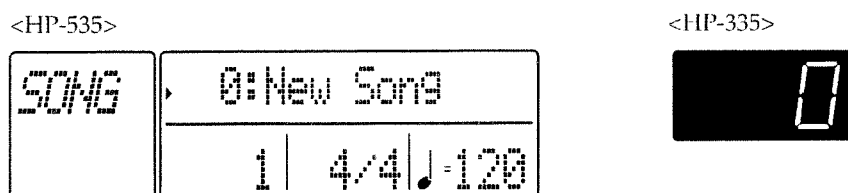

At this point, what is recorded to the [Track] buttons is shown below.

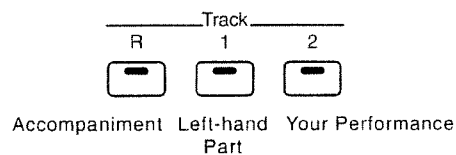

7. Pressing the [Play] button again starts playback of the song with your recorded performance.

Listen to your recording of the right-hand part a few times.

■ Recording the Left-Hand Part

Now try recording and listening to your performance of the left-hand part. To record what the left hand is playing, we must alter part of the sequence for recording the right-hand part (p.33).

- In Step 2 of "Recording the Right-Hand Part", mute the left-hand part of the song by pressing the [1] button; the button's indicator goes off. Then remove the mute on the right-hand part by pressing the [2] button; the button's indicator will go on.
- In Step 4 of "Recording the Right-Hand Part", press the [1] button.

■ Recording With Accompaniment

Try recording your performance using both hands to play one of the songs that feature accompaniment. You will, of course, need to select a song that does feature accompaniment.

To record your performance along with accompaniment, change the following parts of the sequence from "Recording the Right-Hand Part" (p. 33), and then proceed with the recording.

- As in Step 2 of "Recording the Right-Hand Part", mute the right- and left-hand parts of the song by pressing the [1] and [2] buttons, turning their indicators off. Then remove the mute on the accompaniment part by pressing the [R] button; the button's indicator will go on.
- As in Step 4 of "Recording the Right-Hand Part", press the [1] button (Note 2).

(Note 1) What you play will be recorded to any of the [1], [2], or [R] buttons that are pressed. Only sounds from Drum Sets such as GS STANDARD and SOUND EFFECT, and automatic accompaniment tones can be recorded to the [R] button.

(Note 2) By recording the right- hand left-hand parts of your performance separately to the [1] and [2] buttons, you can then listen to each part individually as well.



Selecting a different song, the following appears in the display.

<HP-535>

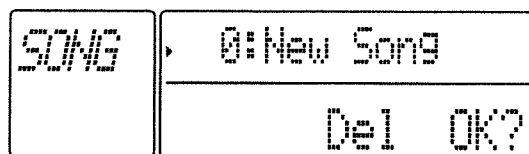

<HP-335>



If the buttons other than [Rec] button are pressed, display returns to previous screen. Press the [Rec] button to erase the recorded data. Until you erase the recorded data, you cannot select a different song.



A recorded song can also be deleted using the method described in "Deleting Recorded Songs" (p.39).



When you want to record your own performance, please refer to "Recording New Songs" (p.36).

Recording New Songs

Now try creating a new song, recording your performance to the three [Track] buttons.

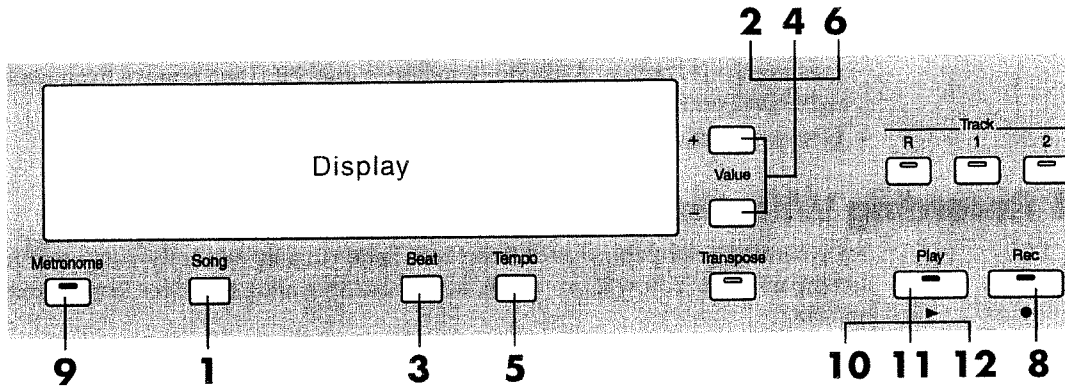

1. Press the [Song] button.
2. Pressing both of the Value [+] and [-] buttons at the same time, select song number "0."

<HP-535>

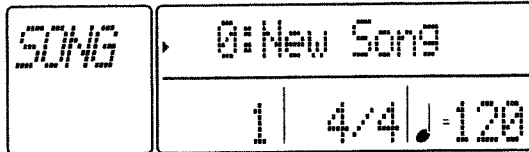

<HP-335>



3. Press the [Beat] button.
4. Use the Value [+] and [-] buttons to set the beat for the song (Note 1).

Display (HP 535)	Display (HP 335)	Beat
2/2	2.2	2/2
0/4	0.4	Quiet beats
2/4	2.4	2/4
3/4	3.4	3/4
4/4	4.4	4/4
5/4	5.4	5/4
6/4	6.4	6/4
7/4	7.4	7/4
3/8	3.8	3/8
6/8	6.8	6/8
9/8	9.8	9/8
12/8	12.8	12/8

5. Press the [Tempo] button.
6. Using the Value [+] and [-] buttons, set the song tempo (Note 2).

7. Select the tone (p.16).

Additionally, set any other desired modes such as Dual Play (p.17) and Split (p.18) (Note 3).

8. Press the [Rec] button to make the indicator lit.

The keyboard is put in record standby mode. The [Play] button and Track button's indicators flash, as does the indicators on all the [Track] buttons for the tracks being recorded to (Note 4).

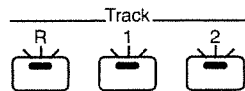

When recording begins, the [Track] buttons are selected automatically. If you wish to cancel the recording, press the [Rec] button again. (Its indicator goes out.)

9. If you want the metronome to sound while you are recording, press the [Metronome] button.

Metronome sound is not recorded.

10. Press the [Play] button.

After two measures of a count sound, recording begins (Note 5). Recording will also begin if you start playing the keyboard without pressing the [Play] button. In this case, no count sound is played.

11. Press the [Play] button once again, and recording stops.

At this point, what is recorded to the Track button is shown below.

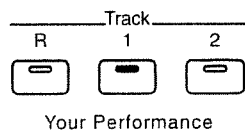

12. Pressing the [Play] button again starts playback of the song with your recorded performance.



Selecting a different song, the following appears in the display.

<HP-535>

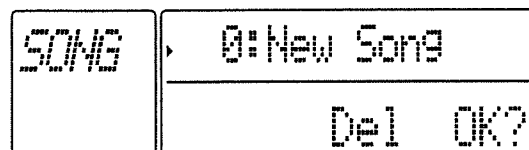

<HP-335>



If the buttons other than [Rec] button are pressed, display returns to previous screen. Press the [Rec] button to erase the recorded data. Until you erase the recorded data, you cannot select a different song.

Try Recording

- (Note 1) You cannot change the beat of a song while recording is in progress. Furthermore, you cannot change the beat used for a recorded song until the recorded song is deleted.
→ “Deleting Recorded Songs” (p.39)
- (Note 2) The tempo of a recorded song also cannot be changed until the song is deleted.
→ “Deleting Recorded Songs” (p.39)
- (Note 3) You cannot put the keyboard in Split mode once recording begins.
→ “Changing the Sounds Played by the Left and Right Hands of the Keyboard— The “Split” Function” (p.18)

With the keyboard in Split mode, recording is as shown below.

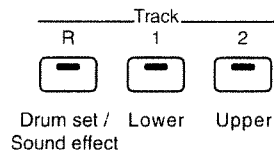

- (Note 4) If any track already has material recorded in it, tracks will not automatically be selected for recording. You will need to press a [Track] button to select a track for recording. The selected [Track] button's indicator flashes.
If you select a track that already has material recorded in it, and then begin recording, the material previously recorded is erased.
Only sounds from Drum Sets such as GS STANDARD Set and SOUND EFFECT, and automatic accompaniment tones can be recorded to the [R] button. These sounds cannot be recorded on tracks [1] and [2].
- (Note 5) When beginning to record, a count sound (unrelated to the [Metronome] button) plays until the start of recording. This count sound cannot be turned off.

■ Recording Performances With Automatic Accompaniment

1. Press the [Pianist] button (p.20).
2. Select a style.
3. Press the [Rec] button, putting the keyboard in record standby mode.
4. Play a chord in the chord recognition part of the keyboard.
Recording will start at the same time as the automatic accompaniment's intro.
5. Press the [Play] button to stop recording.
The piano accompaniment is recorded to the [R] button, and your performance is recorded to the [2] button.

Deleting Sound From Recorded Tracks

You can delete, on an individual track basis, what has been recorded into the tracks. However, the tempo and beat settings cannot be deleted.

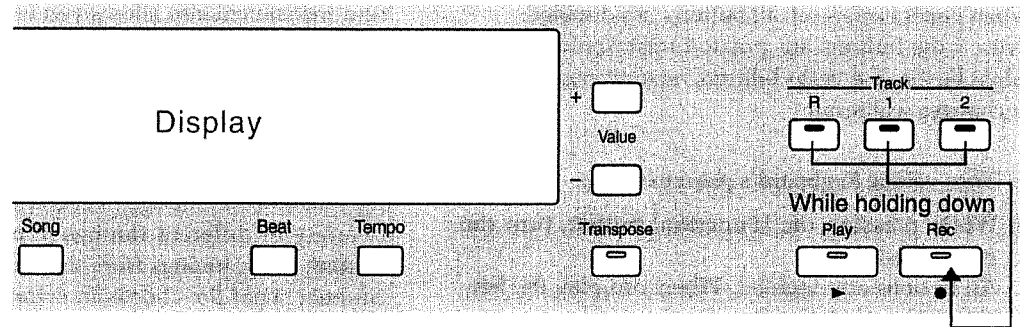

1. While pressing the [Track] button containing the material you want to delete, press the [Rec] button.

The [Track] button's indicator goes out, and the recorded music is deleted.

Deleting Recorded Songs

You can delete recorded songs in their entirety.

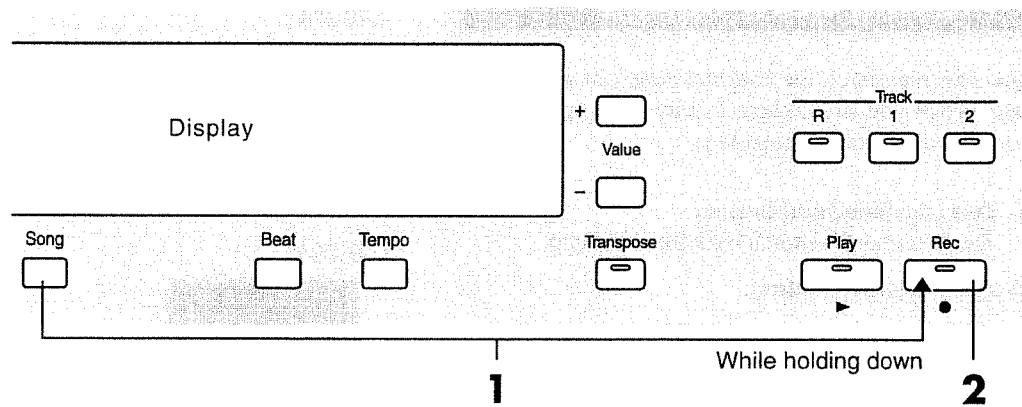

1. While pressing the [Song] button, also press the [Rec] button.

The [Rec] button's indicator then flashes.

A confirmation message appears in the screen.

<HP-535>

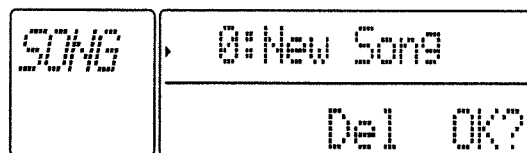

<HP-335>



2. Press the [Rec] button once more.

This deletes the recorded song.

Other Functions

Disabling All Buttons — Panel Lock

When Panel Lock is set, all buttons are disabled. Even if the buttons are pressed mistakenly, such as might be the case with children, no unwanted settings or changes will result.

1. Turn off the keyboard's power switch.
2. While pressing the [Function] button, turn the power back on.

All buttons are disabled. When you play the keyboard "Grand Piano 1" tone is played.

By turning the power off and then on once again, the keyboard returns to its normal status with Panel Lock cancelled.

→ "Turning the Power On and Off" (p.14)

Changing the Key When Playing Back Songs

You can play back the internal songs in a different key. When you then select a different song, the keyboard reverts to its original key.

1. Press the [Function] button.
The [Function] button's indicator lights up.
2. Press the [Play] button.
3. With the Value [+] and [-] buttons, select a key.
Each press of the [+] or [-] button raises or lowers the key by one half-step (semitone).
4. Press the [Function] button.
The [Function] button's indicator goes out.

<HP 535>

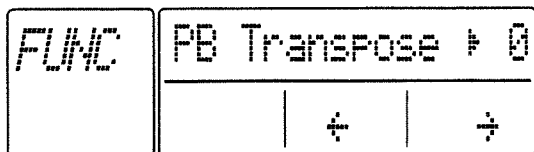

<HP 335>



Playing Songs Using Tunings from Classical Music

Your instrument also allows you to perform using the tunings that were in use at the time that classical music (such as Baroque) was composed.

Most modern songs are composed based on assumption that equal-tempered tuning, the tuning in use almost universally today, will be used when performing. However, in the age of classical music there were a variety of different tunings in existence. Try performing using tunings from those olden times so you can hear what the chords in certain pieces sounded like originally.

Equal temperament is placed in effect each time the keyboard's power is turned on.

1. Press the [Function] button.
The [Function] button's indicator lights up.
2. Press the [E.Piano] button.
3. Using the Value [+] and [-] buttons, select a tuning (Chart 1).

<HP 535>

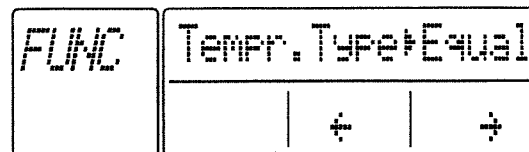

<HP 335>



4. Press the [Harpsi] button.
5. Using the Value [+] and [-] buttons, select a keynote (Chart 2).

When you want to perform using a tuning other than equal temperament, you'll need to specify the keynote (tonic for major, sixth for minor) appropriate for the key of the song you want to play.

<HP 535>

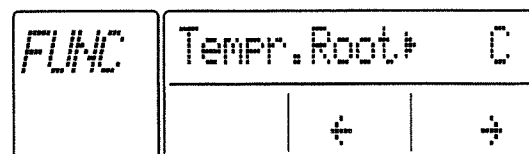

<HP 335>



6. Press the [Function] button.

The [Function] button's indicator goes out.

(Chart 1)

Displayed (HP 535)	Displayed (HP 335)	Characteristics
Equal	1	Equal With this tuning, the octave is divided into twelve equal intervals. Regardless of the interval, very little ambiguity is produced.
Pytha	2	Pythagorean Developed by the philosopher Pythagoras as a method of tuning that resolved the ambiguousness of fourths and fifths. As a result, melodies sound cleaner, but a certain amount of ambiguousness is produced with triads.
J.Maj	3	Just Major This tuning eliminates the ambiguousness of fifths and thirds. This tuning is not suitable for melodies, and transposition is impractical, but rich sonorities can be produced by chords.
J.Min	4	Just Minor Just Major and Minor tunings are different. You can get the same effects in the minor scale as in the major scale.
MeanT	5	Mean Tone A partial compromise of the Just Major tuning, created to make transposition possible.
Werck	6	Werckmeister A combination of the Mean Tone and Pythagorean tunings. This tuning can be used in all keys.
KirnB	7	Kirnberger As a result of improvements made to the Mean Tone and Just temperaments, it is relatively tolerant towards transposition, and can be used to play in all keys.

Each of the notes are indicated on the HP 335's display as shown below.

(Chart 1)

Display	C	d _~	d	E _~	E	F	F _~	G	A _~	A	b _~	b
Keynote	C	D _b	D	E _b	E	F	F#	G	A _b	A	B _b	B

* Songs with tunings other than equal temperament cannot be recorded.

* When performing in ensemble with other instruments, be aware that depending on the key, there may be some shifting of the pitch. Please tune to the other instruments in the ensemble.

Adjusting the Standard Pitch

Middle A is generally used as the standard reference pitch for tuning instruments. When performing in ensemble with other instruments, the ensemble will not sound good if the instruments are not in tune with each other. This tuning of all the instruments to a standard pitch is called "master tuning."

1. Press the [Function] button.

The [Function] button's indicator lights up.

2. Press the [Piano] button.

3. Using the Value [+] and [-] buttons, change the standard pitch.

The standard pitch for the HP 535/335 can be set within the range between 415.3 Hz to 466.2 Hz.

"440.0 Hz" is the power-on default for the standard pitch.

4. Press the [Function] button.

The [Function] button's indicator goes out.

<HP 535>

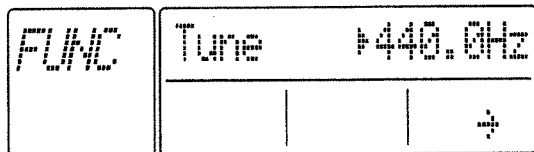

<HP 335>



The latter three digits appear in the display of the HP 335. "440.0 Hz" is indicated in the figure above.

Selecting Tuning Curves

Pianos are commonly tuned so pitches in the lower registers are adjusted relatively flat, and pitches in the higher registers are tuned sharper compared to equal temperament. This kind of tuning method for the piano is called "stretch tuning."

The graphic representation of the differences in pitch when comparing equal-tempered tuning with the actual tuning used is called the "tuning curve." Changing the tuning curve results in a subtle change in the sound of the chords.

"ON" is the power-on default for the tuning curve.

1. Press the [Function] button.

The [Function] button's indicator lights up.

2. Press the [Vibes] button.

3. Using the Value [+] and [-] buttons, change the tuning curve.

Displayed	Characteristics
ON	A tuning curve wherein the low and high registers are widened slightly—low pitches are a little lower, the high pitches a little higher. Appropriate for piano solos.
OFF	Standard tuning curve. This is the right choice when using Dual Play, or when playing in ensemble with other instruments.

4. Press the [Function] button.

The [Function] button's indicator goes out.

<HP 535>

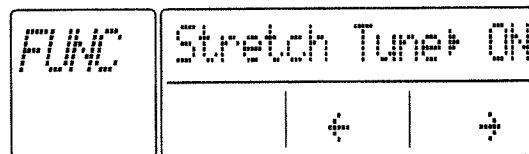

<HP 335>



* This setting is only available with piano tones.

* The tuning curve can be selected even with tunings other than equal temperament.

Changing Various Settings

Changing the Pedal Operations

Although the sostenuto pedal (the center pedal) originally only worked to sustain whatever note was being played the instant the pedal was depressed and hold the note until the pedal was released, on the HP 535/335, the following functions have also been assigned to the pedal. When the keyboard is turned on, it is set to work in the original manner.

• Adding Sustain to the Lower Part of the Keyboard

With the keyboard in Split mode, sustain (like that when the damper pedal is depressed) is applied to the left-hand part of the keyboard.

1. Press the [Function] button.

The [Function] button's indicator lights up.

2. Press the [Orgn] button.

3. Using the Value [+] and [-] buttons, change the pedal's operation.

	Displayed (HP 535)	(HP 335)	Pedal Operation
UprSost	1		Normal pedal operation
LwrDmpr	2		Sustain added to the left keys

4. Press the [Function] button.

The [Function] button's indicator goes out.

<HP 535>

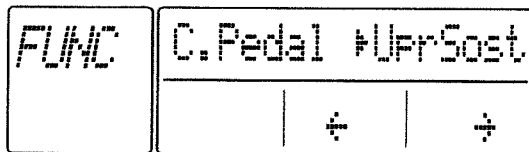

<HP 335>



→ "About the Pedals" (p.12)

Changing the Depth of the Chorus Effect

The depth of the chorus effect can set to any of the ten levels of depth that are available. Chorus is set to "3" when the keyboard is turned on.

1. Holding down the [Chorus] button and using the Value [+] and [-] buttons to adjust the chorus depth.

As this value is increased the sound will be deeper and more spacious.

<HP 535>

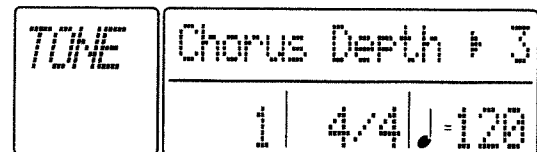

<HP 335>



● The following method can also be used to adjust chorus depth.

1. Press the [Function] button.

The [Function] button's indicator lights up.

2. Press the [Chorus] button.

3. Using the Value [+] and [-] buttons, adjust the depth of the chorus.

4. Press the [Function] button.

The [Function] button's indicator goes out.

→ "Adding Breadth to the Sound— Chorus Effect" (p.24)

Changing Various Settings

Changing the Depth of the Reverb Effect

The depth of the reverb effect can also be adjusted. There are ten levels of depth from which to choose. Reverb is set to “5” when the keyboard is turned on.

1. Holding down the [Reverb] button and the using the Value [+] and [-] buttons to adjust the reverb depth.

As this value is increased the reverb will apply more strongly.

<HP 535>

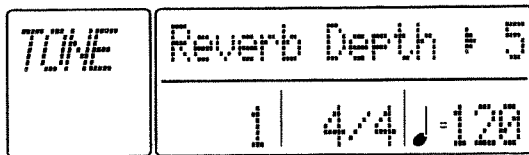

<HP 335>



- The following method can also be used to adjust the reverb depth.

1. Press the [Function] button.
The [Function] button's indicator lights up.
2. Press the [Reverb] button.
3. Using the Value [+] and [-] buttons, adjust the depth of the reverb.
4. Press the [Function] button.
The [Function] button's indicator goes out.

→ “Adding Reverberation to the Sound— Reverb Effect” (p.24)

Changing the Damper Pedal's Resonance

On acoustic pianos, when the damper pedal is depressed, additional strings are released to resonate with the sound of the keys that have been played, adding richness and breadth to the sound. The damper pedal on the HP 535/335 recreates this resonance when depressed. Ten levels of resonance are available; the higher the value, the deeper the resonance. This effect works only with the piano tones. Resonance is set to “5” when the keyboard is turned on.

1. Holding down the [Reverb] button and the [Chorus] button simultaneously, and the using the Value [+] and [-] buttons to adjust the depth of the resonance.

<HP 535>

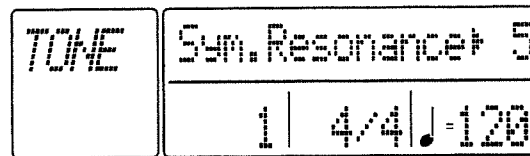

<HP 335>



- The following method can also be used to adjust the resonance depth (HP 535).

1. Press the [Function] button.
The [Function] button's indicator lights up.
2. Press the [Chorus] button.
3. Press the [Tempo] button once.
4. Using the Value [+] and [-] buttons, adjust the depth of the resonance.
5. Press the [Function] button.
The [Function] button's indicator goes out.

→ “About the Pedals” (p.12)

Changing the Keyboard's Split Point

When in Split mode, you can move the keyboard's split point to any key from B1 to B6. "F#3" is the power-on default for the split point.

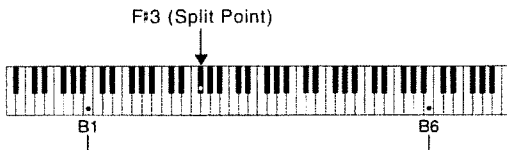

1. While pressing the [Split] button, press one of the keys on the keyboard.
The pressed key becomes the split point.

<HP 535>

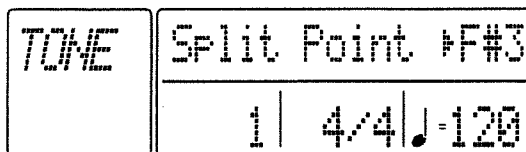

<HP 335>



- The split point can also be changed using the following two methods.

○ Method 1

1. Using the Value [+] and [-] buttons while pressing the [Split] button.

Pressing the [+] button once moves the split point one key to the upper; pressing the [-] button once moves the split point one key to the lower.

○ Method 2

1. Press the [Function] button.
The [Function] button's indicator lights up.
2. Press the [Split] button.
3. Using the Value [+] and [-] buttons, change the split point.
4. Press the [Function] button.
The [Function] button's indicator goes out.

→ "Changing the Sounds Played by the Left and Right Hands of the Keyboard — The "Split" Function" (p.18)

Changing the Volume Balance in Dual Play

You can change the volume balance between the two layered sounds in Dual Play. "5-5" is the power-on default for the balance (left-side button volume/right-side button volume).

1. Press the [Function] button.
The [Function] button's indicator lights up.
2. Press the [Key Touch] button.
3. Using the Value [+] and [-] buttons, adjust the volume balance.
4. Press the [Function] button.
The [Function] button's indicator goes out.

<HP 535>

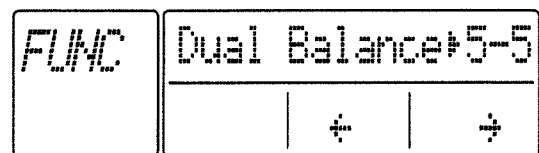

<HP 335>



→ "Layering Two Instrument Sounds— Dual Play" (p.17)

Changing Various Settings

Changing the Volume Balance Between the Song and the Keyboard

You can change the balance of volume between the parts played on the keyboard and the internal songs and accompaniment.

"5-5" is the power-on default for the balance (keyboard volume/internal song or accompaniment volume).

1. Holding down the [Pianist] button and then using the Value [+] and [-] buttons to adjust the volume balance.

<HP 535>

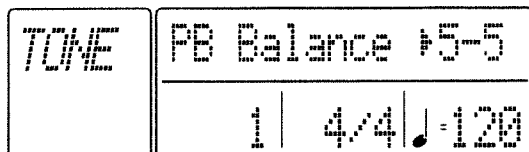

<HP 335>



- The volume balance can also be adjusted by the following method.

1. Press the [Function] button.
The [Function] button's indicator lights up.
2. Press the [Pianist] button.
3. Using the Value [+] and [-] buttons, adjust the volume balance.
4. Press the [Function] button.
The [Function] button's indicator goes out.

→ "Practicing Along with a Song" (p.31)

→ "Playing Along with the Auto-Accompaniment—The "Pianist" Function" (p.20)

Changing the Metronome Volume

The volume of the metronome can be adjusted, with ten volume levels available. The volume is set to "5" when the keyboard is turned on.

1. Holding down the [Metronome] button and the using the Value [+] and [-] buttons to adjust the volume.

The volume of the metronome is changed.

<HP 535>

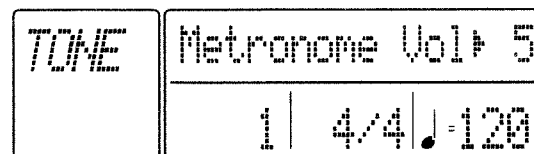

<HP 335>



- The metronome volume can also be adjusted by the following method.

1. Press the [Function] button.
The [Function] button's indicator lights up.
2. Press the [metronome] button.
3. Using the Value [+] and [-] buttons, adjust the metronome volume.
4. Press the [Function] button.
The [Function] button's indicator goes out.

→ "Sounding the Metronome" (p.25)

Changing the Metronome Settings (HP 535)

The metronome's setting can be changed as follows:

1. Press the [Function] button.
The [Function] button's indicator light up.
2. Press the [Metronome] button.

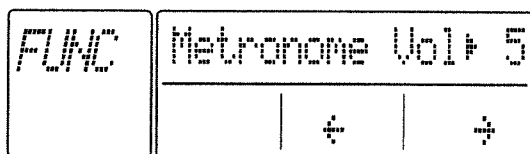

3. Pressing the [Tempo] button or [Beat] button causes the item you want to adjust to appear in the display.

Displayed	Meaning
-----------	---------

Metronome Vol

The metronome volume can be adjusted in ten levels. The volume is set to [5] when the keyboard is turned on.

Mtr. Sound

You can change the metronome sound. The sound is set to [Click] when the keyboard is turned on.

"Mtr. Ptrn"

You can change the metronome pattern. The pattern is set to [Normal] when the keyboard is turned on.

4. Use the Value [+] and [-] buttons to make your setting.
5. Press the [Function] button.
The [Function] button's indicator goes out.

○ Metronome Tones

Displayed	Type
Click	Normal Metronome sound (Click & Bell)
Elec.	Electronic Metronome Sound
Voice	Voice (One, two, three,..)
Animal	Dog & Cat Sounds

○ Metronome Patterns

Type	Meaning
Normal	Ordinary beat, with no pickup.
	Plays with a dotted half note pickup before the beginning of the measure.
	Plays with a half note pickup before the beginning of the measure.
	Plays with a dotted quarter note pickup before the beginning of the measure.
	Plays with a quarter note pickup before the beginning of the measure.
	Plays with a dotted eighth note pickup before the beginning of the measure.
	Plays with a sixteenth note pickup before the beginning of the measure.
+Doubl	Plays with backbeats as the added sound.
+Tripl	Plays with triplets as the added sound.
+Shuf	Adds a shuffle.

→ "Sounding the Metronome" (p.25)

Changing Various Settings

Disabling the Beat Indicator's Pulsations

Perform the steps below to get the beat indicator to stop blinking on and off. "ON" is the power-on default for the indicator.

1. Press the [Function] button.

The [Function] button's indicator lights up.

2. Press the [Song] button.

<HP 535>

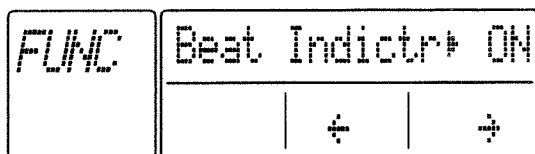

<HP 335>



3. Using the Value [+] and [-] buttons, toggle between ON and OFF.

4. Press the [Function] button.

The [Function] button's indicator goes out.

→ "About the Display Screen" (p. 10)

Turning off the Bouncing Ball (HP 535)

You can turn off the bouncing ball.

"ON" is the power-on default for the bouncing ball.

1. Press the [Function] button.

The [Function] button's indicator lights up.

2. Press the [Song] button.

3. Press the [Tempo] button once.

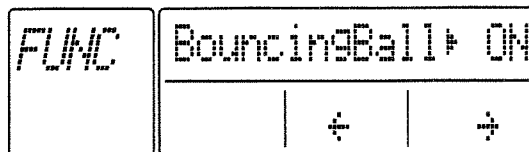

4. Use the Value [+] and [-] buttons to select either "ON" and "OFF."

5. Press the [Function] button.

The [Function] button's indicator goes out.

Switching the Language on the Display Screen (HP 535)

The HP 535's display can be switched to either Japanese or English. Once set, the screen language preference will be remembered until the setting will be changed again, and will be put in effect every time power is turned on.

1. Press the [Function] button.

The [Function] button's indicator lights up.

2. Press the [Song] button.

3. Press the [Tempo] button twice.

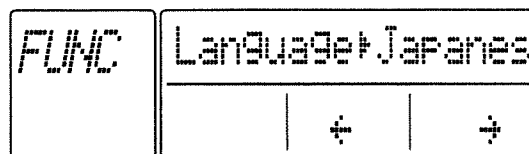

4. Use the Value [+] and [-] buttons to select either Japanese or English.

5. Press the [Function] button.

The [Function] button's indicator goes out.

Connecting External Devices

The following section is necessary for those who wish to connect the keyboard to other equipment.

Connection Jacks —Names and Functions

The functions of the jacks on the rear panel and underside are described below.

● Rear Panel

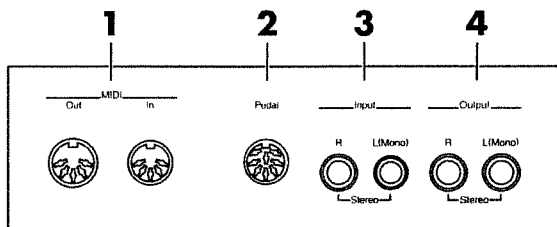

1. MIDI Out/In Jack

You can connect external MIDI devices to the HP 535/335 and exchange performance data between them.

* There is also a MIDI In jack on the underside of the HP 535/335. However, two MIDI In jacks cannot be used at the same time.

2. Pedal Jack

This is for connecting the separate stand pedal cord.

3. Input Jack

Using this jack, you can connect other sound generating devices and play sounds from other devices through the HP 535/335's speaker.

4. Output Jack

By connecting the HP 535/335 to audio equipment or similar arrangements you can enjoy sound that has more power. Additionally, by connecting the keyboard to a radio/cassette player, you can record your performances on cassette tapes.

● Underside

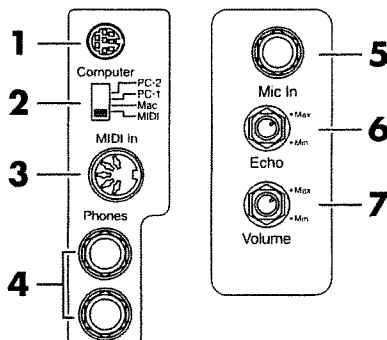

1. Computer Jack

You can connect a computer to the HP 535/335 and exchange performance data between the two (p.50).

2. Computer Switch

The setting for this switch is made depending on the computer connected— Mac/PC-1/PC-2. Additionally, this switches between MIDI In jack and the Computer jack (p.50).

* The MIDI Out/In jack and the computer jack cannot be used at the same time.

3. MIDI In Jack

You can connect external MIDI devices to the HP 535 and exchange performance data between them.

* There is also a MIDI In jack on the rear panel of the HP 535. However, two MIDI In jacks cannot be used at the same time.

4. Phones Jack

For more information about the Phones jack, please refer to "Connecting Headphones" (p.13).

5. Mic In Jack

6. Echo Knob

7. Volume Knob

For more information about these, please refer to "Connecting a Microphone" (p.13).

Making Connections

Caution!

When using cables to connect the HP 535/335 with other equipment, make sure you follow the procedure below. Failure to follow these steps in the order given could cause a malfunction and/or damage to speakers or other equipment.

1. Turn the volume down completely on all equipment.
2. Turn off the HP 535/335 and any other devices to be connected.
3. Connect all cables and make all other connections.
4. Turn on the power to the connected equipment.
5. Turn on the power to the HP 535/335.
6. Adjust the volume.

After use, turn off the power using the following procedure.

1. Turn the volume down completely on all equipment.
2. Turn off the power to the HP 535/335.
3. Turn off the power to the equipment that is connected with the HP 535/335.

Connecting External Devices

● Connecting to MIDI Devices

By connecting the keyboard to MIDI devices such as those in Roland's MT Series, you can have the sound from the MT Series devices played through the keyboard's speakers, as well as save keyboard performances you have recorded to MT Series equipment. For more information, please refer to the owner's manuals for each device.

→ "Using MIDI" (p. 51)

● Connecting to Audio Equipment

With the keyboard connected to audio equipment, you can record your keyboard performances on a tape recorder. Use an audio cable (not included with the keyboard) to connect the input jack of your stereo or amp/mixer with the output jack of the HP 535/335.

● Connecting to Computers

By connecting the keyboard to a computer with software such as Roland's "Visual MT" installed, you can play sounds from the software's sound generator through the keyboard's speakers, as well as save keyboard performances you have recorded to the computer.

■ Connecting with a Computer

1. Turn off the power to the HP 535/335 and the computer.
2. Using a compatible computer cable (RSC-15APL/RSC-15AT/RSC-15N: sold separately), connect the Computer jack on the underside of the keyboard with the computer's serial port.
3. Set the computer switch on the underside of the keyboard to match the type of computer connected.
Please refer to the connection examples below.
4. Turn on the power to the computer.
5. Turn on the power to the HP 535/335.
6. Set the computer's and software's baud rates to match each other.
For more information on this procedure, please refer to the owner's manual for your computer.
7. If applicable, set the MIDI Send channel (p.51) and Local On/Off (p.52).

Connection Examples:

○ When Connecting to an Apple Macintosh Computer

Using a compatible computer cable (RSC-15APL: sold separately), connect the Apple Macintosh series computer's modem port or printer port with the Computer jack of the HP 535/335, and set the computer switch to "Mac."

When using the Macintosh "Patch Bay" utility, specify 1 MHz as the Interface Type (MIDI Interface Clock).

○ When Connecting to an IBM PC Model Computer

Using a compatible computer cable (RSC-15AT: sold separately), connect the IBM PC's COM 1 or COM 2 serial ports with the Computer jack of the HP 535/335, and set the computer switch to "PC-2."

Using MIDI

● About MIDI

MIDI, short for “Musical Instrument Digital Interface,” was developed as a standard for the exchange of performance data between electronic instruments and computers.

The HP 535/335 is equipped with MIDI and computer jacks to allow such exchange of performance data with external equipment and devices. Connecting the keyboard to other devices with these jacks provides you with an even greater variety of ways to use your keyboard.

A separate publication titled “MIDI Implementation” is also available. It provides complete details concerning the way MIDI has been implemented on this unit. If you should require this publication (such as when you intend to carry out byte-level programming), please contact the nearest Roland Service Center or authorized Roland distributor.

● About the MIDI Jacks

The HP 535/335 feature two types of MIDI connectors. You can connect these connectors to the MIDI connectors of other MIDI devices so that the instruments can control each other. For example, sounds from the connected device can be played by the keyboard, tones can be changed, and so on.

○ MIDI Out Jack

Performance information such as the output from the keyboard is sent out here to the MIDI jacks of external equipment.

○ MIDI In Jack

MIDI information sent from connected external equipment is input here. MIDI devices that receive MIDI information can output sounds, exchange tones, and perform other operations.

** There are two MIDI In jacks; one on the rear panel, and another on the underside of the HP 535/335. However, the two MIDI In jacks cannot be used at the same time.*

■ Making Connections to MIDI Devices

1. Turn off the power to the HP 535/335.
2. Set the computer switch on the underside of the keyboard to “MIDI.”
3. Using a MIDI cable (MSC-15/25/50: sold separately), connect the MIDI jack/connector of the connected MIDI equipment to the HP 535/335’s MIDI jack.
4. If applicable, set the MIDI Send channel (p.51) and Local On/Off (p.52).

Connection Examples:

○ Connecting to a MIDI Device

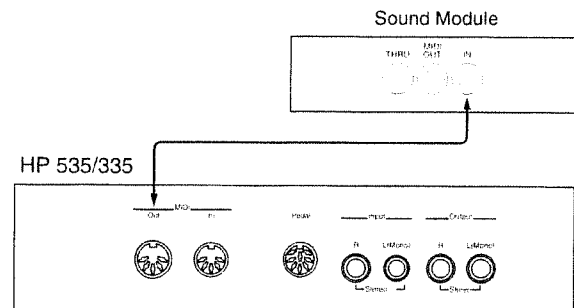

○ Connecting to the Roland MT Series

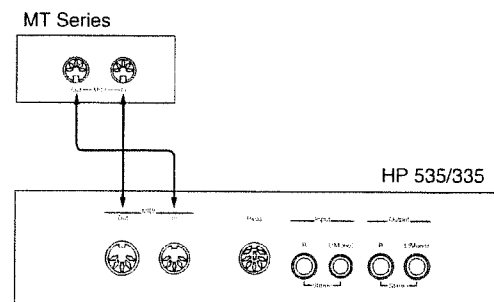

■ MIDI Settings

With the HP 535/335, you can make MIDI settings as shown below.

○ Selecting the MIDI Send Channel

MIDI features sixteen MIDI channels, numbered 1–16. Even after the cable is connected, the connected devices must be set to use the same MIDI channels, otherwise no sound will be produced, and no sounds can be selected.

The HP 535/335 selects the MIDI channel used for sending information from the keyboard. When the keyboard is turned on, Channel “1” is selected.

In Split mode, the lower part of the keyboard is not sent.

The HP 535/335 receives all sixteen channels.

○ Sending Recorded Performance Data to MIDI Devices

You can have your recorded performances be sent to connected MIDI devices or computers.

Switch to “ON” to allow performances to sent, “OFF” to prevent sending.

“OFF” is the power-on default for this setting.

Connecting External Devices

1. Record something on the HP 535/335.
2. Set to "ON."
3. Start recording with the connected MIDI device.
4. Start playback of the recorded song on the HP 535/335.

○ Transmission of Program Changes

The HP 535/335 can be used to remotely change the sounds that a connected MIDI device uses. For more about the tones that will be switched to when program changes are received, please consult with Roland Service.

○ Switching Local On-Off

With the keyboard connected to a MIDI sequencer, keyboard performances can be recorded to the sequencer; the sequencer can also be used to play back performances.

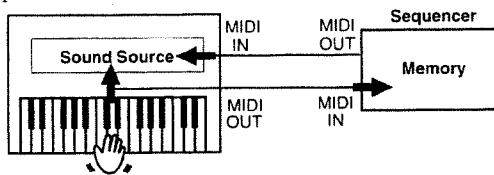

With the sequencer's "Thru" function on, the same notes will be sounded twice. This is because the keyboard's performance data arrives at the sound generator via two different routes, (1) and (2). This can cause the sound to become strange, and also puts strain on the instrument's polyphonic capabilities. To prevent this from happening, route (1) must be separated, by means of what is called "Local Off."

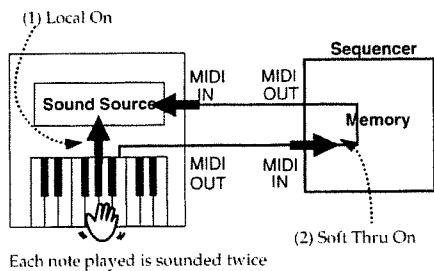

Local On: The keyboard and internal sound generator are connected.

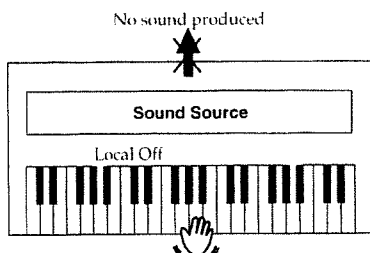

Local Off: The keyboard and internal sound generator are separated. No sound will be produced by the keyboard when it is played.

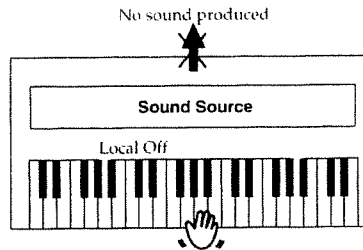

* "Local On" is the power-on default.

* MIDI sequencers are devices that record and play back performances as MIDI information. The models in Roland's MT Series feature sequencers and sound generators in a single unit.

The Local On/Off setting is based on the MIDI local control information that is received. When one of the MT Series models is connected, Local Off data is transmitted when the MT is turned on. If first the HP 535/335, and then the MT is turned on, the HP 535/335 automatically selects Local Off.

■ How to Make Settings

1. Press the [Function] button.

The [Function] button's indicator lights up.

2. Press each settings button.

- To select the MIDI send channel
→ [Strings] button
- To send recorded performance information
→ [Rec] button
- Program send changes
→ [GS Tones] button
- To switch Local On/Off
→ [Choir] button

3. Using the Value [+] and [-] buttons, make the settings.

4. Press the [Function] button.

The [Function] button's indicator goes out.

Trouble shooting

If you are encountering any problems with the equipment, please read the section below before determining that there has been any malfunction.

- **The keyboard does not switch on.**

- Is the power cord properly connected? (p. 14)

- **No sound is produced.**

- Is the volume slider completely to the left (turned completely down)? (p.15)
- Are headphones connected?
When headphones are connected, the keyboard's speaker stops playing (p.13).
- Is Local On/Off set to "Off?" (p.52)

- **No sound (when connected to MIDI device)**

- Is the power to all equipment turned on? (p.49)
- Is the computer switch on the underside of the keyboard set to "MIDI?" (p.49)

- **Internal songs do not play.**

- Has the internal song's playback volume setting been changes, with the volume set to minimum? (p.46)
- Are the [Track] button indicators all off?
No sound is played from tracks whose button indicators are off. Press the buttons to turn the button indicators on (p. 31).
- During recording or playback of a song, you cannot listen to another song. To listen to a different song, first stop the recording or playback. (p.28, 33)
- Is Panel Lock on? (p.40)

- **Two sounds are produced when the keyboard is played.**

- Is the keyboard in Dual Play mode? (p.17)
- When the HP 535/335 is connected to an external sequencer, set it to the Local OFF mode (p.52). Alternatively, the sequencer could be set so its Soft Thru feature is OFF.

- **Not all sounds played are audible.**

- The HP 535/335 can play a maximum of 64 sounds simultaneously. When playing along with internal songs, heavy use of the damper pedal can result in performance data with a number of sounds in excess of this limit, with some sounds being omitted.

- **The pitch of the keyboard or internal songs has shifted.**

- Is the [Transpose] button indicator lit?
Press the [Transpose] button, extinguishing the indicator, to turn off the transpose function (p.22).
- Has the song been transposed? (p.40)
- Is the tuning or tuning curve setting correct? (p.40, 42)
- Is the Master Tuning setting correct? (p.42)

- **The pedals are not functioning, or function intermittently.**

- Are the pedals connected properly?
Be sure that the pedal cord from the stand is securely connected into the pedal jack on the rear panel of the keyboard (p.49).

- **Can't Record**

- Is Panel Lock on? (p.40)
- Have you selected a [Track] button for recording? (p.38, Note 4)

- **The recorded performance has been deleted.**

- Recorded material is deleted when the keyboard is turned off. Deleted performances cannot be retrieved.

- **The bouncing ball does not appear on the screen (HP 535).**

- Is the bouncing ball setting set to "Off?"
Set the bouncing ball to "On" (p.48).
- The HP 535/335 features a liquid crystal display. Characters may begin to disappear in freezing conditions. Once above zero degrees Celsius (32 degrees Fahrenheit), the characters reappear.

Error Messages

HP 535: PU

HP 335: PU

Meaning: When songs with pickups (song that don't start on the first beat) are played back, the measure numbers are indicated on the display screen as "PU," "1," "2,"...

HP 535: New Song Del OK?

HP 335: dEL

Meaning: This appears when you attempt to delete a recorded song (refer to p.39). Additionally, this appears after recording a song when you try to select another song (refer to p.35, 37).

HP 535: E.32:Memory Full

HP 335: E.32

Meaning: The amount of performance information is too large, and further recording is not possible.

HP 535: E.40:Buffer Full

HP 335: E.40

Meaning: Too much MIDI data was sent from the external MIDI instrument at one time, and the unit could not process the data. Reduce the amount of MIDI data being sent to the HP-335/535.

HP 535: E.41 :Comm.Error

HP 335: E.41

Meaning: A problem such as a loose MIDI cable or computer cable occurred.
Make sure the MIDI cables and computer cables are correctly hooked up.

HP 535: E.43:Framing Err

HP 335: E.43

Meaning: The setting of the Computer switch on the rear panel is incorrect, or the computer settings are incorrect.
Switch off the power and set the Computer switch correctly, then turn the power back on. Alternatively, make sure the computer settings are correct (p.50).

HP 535: E.51 :System Err

HP 335: E.51

Meaning: A System error has occurred. Try the operation again.
If you cannot register the setting to the internal memory, please contact qualified service personnel.

List of Tone Names

→ “Performing with Various Instrument Sounds” (p. 16)

Tones with an asterisk “*” can only be recorded on the [R] button.

[Piano] Group

No.	Tone Name
1	Grand Piano1
2	Grand Piano2
3	UprightPiano
4	Rock Piano
5	Honky-tonk 1
6	Honky-tonk 2
7	MIDI Piano1
8	MIDI Piano2

[E.Piano] Group

No.	Tone Name
1	E.Piano 1
2	Soft E.Piano
3	E.Piano 2
4	Hard E.Piano
5	60's E.Piano

[Harpsi] Group

No.	Tone Name
1	Harpsichord1
2	Harpsichord2
3	Clav.
4	Nylon Guitar
5	Steel-str.Gt
6	Banjo
7	Jazz Guitar
8	Overdrive Gt
9	DistirtionGt
10	Shamisen
11	Koto

[Vibes] Group

No.	Tone Name
1	Vibraphone
2	Celesta
3	Marimba
4	Xylophone
5	Glockenspiel
6	Music Box
7	Tubular-bell
8	Santur
9	Steel Drums
10	Kalimba

[Organ] Group

No.	Tone Name
1	Church Organ
2	Jazz Organ 1
3	Full Organ 1
4	Pop Organ
5	Accordion
6	Harmonica

[Strings] Group

No.	Tone Name
1	Strings
2	Slow Strings
3	Violin
4	Cello
5	Harp
6	Orchestra
7	Syn.Strings1
8	Warm Pad
9	Harpvox
10	CC Solo

[Choir] Group

No.	Tone Name
1	Choir
2	Pop Voice
3	SynVox
4	Trumpet
5	Trombone
6	MutedTrumpet
7	French Horn
8	Brass 1
9	Synth Brass1
10	Synth Brass2
11	Tenor Sax
12	Soprano Sax
13	Alto Sax
14	Oboe
15	Bassoon
16	Clarinet
17	Flute
18	Pan Flute

[GS Tones] Group

No.	Tone Name
1	Fantasia
2	Brightness
3	Crystal
4	GS STANDARD*
5	SOUND EFFECT*
6	Piano 1
7	Piano 1w
8	Piano 1d
9	Piano 2
10	Piano 2w
11	Piano 3
12	Piano 3w
13	Honky-tonk
14	Honky-tonk 2
15	E.Piano 1
16	Detuned EP 1
17	E.Piano 1v
18	60's E.Piano

19	GS E.Piano2
20	Detuned EP 2
21	E.Piano 2v
22	Harpsichord
23	Coupled Hps.
24	Harpsi.w
25	Harpsi.o
26	Clav.
27	Celesta
28	Glockenspiel
29	Music Box
30	GS Vibe
31	Vibe.w
32	GS Marimba
33	Marimba
34	Xylophone
35	Tubular-bell
36	Church Bell
37	Carillon
38	GS Santur
39	Organ 1
40	Detuned Or.1
41	Pop Organ 1
42	Full Organ 4
43	Organ 2
44	Detuned Or.2
45	Jazz Organ 1
46	Rock Organ 2
47	Church Org.1
48	Church Org.2
49	Church Org.3
50	Reed Organ
51	Accordion Fr
52	Accordion It
53	Harmonica
54	Bandoneon
55	GS Nylon Gt.
56	Ukulele
57	Nylon Gt.o
58	Nylon Guitar
59	Steel-str.Gt
60	12-str.Gt
61	Mandolin
62	Jazz Guitar
63	Hawaiian Gt.
64	Clean Gt.
65	Chorus Gt.
66	Muted Gt.
67	Funk Gt.
68	Funk Gt.2
69	Overdrive Gt
70	Distortion Gt
71	Feedback Gt.
72	Gt.Harmonics
73	Gt. Feedback
74	Acoustic Bs.

List of Tone Names

75	Fingered Bs.	134	Shakuhachi	193	Seashore
76	Picked Bs.	135	Whistle	194	Rain
77	Fretless Bs.	136	Ocarina	195	Thunder
78	Slap Bass 1	137	Square Wave	196	Wind
79	Slap Bass 2	138	Square	197	Stream
80	Synth Bass 1	139	Sine Wave	198	Bubble
81	SynthBass101	140	Saw Wave	199	Bird
82	Synth Bass 3	141	Saw	200	Dog
83	Synth Bass 2	142	Doctor Solo	201	Horse-Gallop
84	Synth Bass 4	143	Syn.Calliope	202	Bird 2
85	Rubber Bass	144	Chiffer Lead	203	Telephone 1
86	Violin	145	Charang	204	Telephone 2
87	Slow Violin	146	Solo Vox	205	DoorCreaking
88	Viola	147	5th Saw Wave	206	Door
89	Cello	148	Bass & Lead	207	Scratch
90	Contrabass	149	Warm Pad	208	Windchime
91	Tremolo Str	150	Polysynth	209	Helicopter
92	PizzicatoStr	151	Space Voice	210	Car-Engine
93	GS Harp	152	Bowed Glass	211	Car-Stop
94	Timpani	153	Metal Pad	212	Car-Pass
95	GS Strings	154	Halo Pad	213	Car-Crash
96	Orchestra	155	Sweep Pad	214	Siren
97	GS Sl.Str	156	Ice Rain	215	Train
98	Syn.Strings1	157	Soundtrack	216	Jetplane
99	Syn.Strings3	158	Syn Mallet	217	Starship
100	Syn.Strings2	159	Atmosphere	218	Burst Noise
101	Choir Aahs	160	Goblin	219	Applause
102	Choir	161	Echo Drops	220	Laughing
103	Pop Voice	162	Echo Bell	221	Screaming
104	SynVox	163	Echo Pan	222	Punch
105	OrchestraHit	164	Star Theme	223	Heart Beat
106	Trumpet	165	Sitar	224	Footsteps
107	GS Trombone	166	Sitar 2	225	Gun Shot
108	Trombone 2	167	Banjo	226	Machine Gun
109	Tuba	168	Shamisen	227	Lasergun
110	MutedTrumpet	169	Koto	228	Explosion
111	French Horn	170	Taisho Koto	229	GS ROOM*
112	Fr.Horn 2	171	Kalimba	230	ROWER*
113	Brass 1	172	Bagpipe	231	ELECTRIC*
114	Brass 2	173	Fiddle	232	TR-808*
115	Synth Brass1	174	Shanai	233	JAZZ*
116	Synth Brass3	175	Tinkle Bell	234	GS BRUSH*
117	AnalogBrass1	176	Agogo	235	ORCHESTRA*
118	Synth Brass2	177	Steel Drums		
119	Synth Brass4	178	Woodblock		
120	AnalogBrass2	179	Castanets		
121	Soprano Sax	180	Taiko		
122	Alto Sax	181	Concert BD		
123	Tenor Sax	182	Melo. Tom 1		
124	Baritone Sax	183	Melo. Tom 2		
125	Oboe	184	Synth Drum		
126	English Horn	185	808 Tom		
127	Bassoon	186	Elec Perc.		
128	Clarinet	187	Reverse Cym.		
129	Piccolo	188	Gt.FretNoise		
130	Flute	189	Gt.Cut Noise		
131	Recorder	190	String Slap		
132	Pan Flute	191	Breath Noise		
133	Bottle Blow	192	Fl.Key Click		

List of Tone Names

The Drum Set (percussion instrument) and SOUND EFFECT have a variety of different sounds assigned to each key.

The Drum Set is in the [GS Tones] button tone group.

	4: GS STANDARD 233: JAZZ	229: GS ROOM	230: POWER	231: ELECTRIC	232: TR-808
24	Bar Chime				
25	Snare Roll	-----			
26	Finger Snap	-----			
27	High Q				
28	Slap				
29	Scratch Push [EXC7]				
30	Scratch Pull [EXC7]				
31	Sticks				
32	Square Click				
33	Metronome Click				
34	Metronome Bell				
35	Std Kick 2				
C2 36	Std Kick 1		MONDO Kick	Elec BD	808 Bass Drum 1
37	Side Stick				808 Rim Shot
38	Snare Drum 1		Gated SD	Elec SD	808 Snare Drum
39	Hand Clap				
40	Snare Drum 2			Gated SD	
41	Low Tom 2	Room Low Tom 2	Room Low Tom 2	Elec Low Tom 2	808 Low Tom 2
42	Closed Hi-hat 1 [EXC1]				808 CHH [EXC1]
43	Low Tom 1	Room Low Tom 1	Room Low Tom 1	Elec Low Tom 1	808 Low Tom 1
44	Pedal Hi-hat 1 [EXC1]				808 CHH [EXC1]
45	Mid Tom 2	Room Mid Tom 2	Room Mid Tom 2	Elec Mid Tom 2	808 Mid Tom 2
46	Open Hi-hat 1 [EXC1]				808 OHH [EXC1]
47	Mid Tom 1	Room Mid Tom 1	Room Mid Tom 1	Elec Mid Tom 1	808 Mid Tom 1
C3 48	High Tom 2	Room Hi Tom 2	Room Hi Tom 2	Elec Hi Tom 2	808 Hi Tom 2
49	Crash Cymbal 1				808 Cymbal
50	High Tom 1	Room Hi Tom 1	Room Hi Tom 1	Elec Hi Tom 1	808 Hi Tom 1
51	Ride Cymbal 1				
52	Chinese Cymbal			Reverse Cymbal	
53	Ride Bell				
54	Tambourine				
55	Splash Cymbal				
56	Cowbell				808 Cowbell
57	Crash Cymbal 2				
58	Vibra-slap				
59	Ride Cymbal 2				
C4 60	High Bongo				
61	Low Bongo				
62	Mute High Conga				808 High Conga
63	Open High Conga				808 Mid Conga
64	Low Conga				808 Low Conga
65	High Timbale				
66	Low Timbale				
67	High Agogo				
68	Low Agogo				
69	Cabasa				
70	Maracas				808 Maracas
71	Short Hi Whistle [EXC2]				
C5 72	Long Low Whistle [EXC2]				
73	Short Guiro [EXC3]				
74	Long Guiro [EXC3]				
75	Claves				808 Claves
76	High Wood Block				
77	Low Wood Block				
78	Mute Cuica [EXC4]				
79	Open Cuica [EXC4]				
80	Mute Triangle [EXC5]				
81	Open Triangle [EXC5]				
82	Shaker				
83	Jingle Bell				
C6 84	Bell Tree				
85	Castanets				
86	Mute Surdo [EXC6]				
87	Open Surdo [EXC6]				
88	-----	-----	-----	-----	-----

List of Tone Names

234: GS BRUSH		235: ORCHESTRA
24	25	
26		
28	27	
29		Close Hi-hat [EXC1]
31	30	Pedal Hi-hat [EXC1]
32		Open Hi-hat [EXC1]
33		Ride Cymbal
35	34	
C2		Concert BD 2
36		Concert BD 1
37		
38	Brush Tap	Concert SD
39	Brush Slap	Castanets
40	Brush Swirl	Concert SD
41		Timpani F
42		Timpani F#
43		Timpani G
44		Timpani G#
45		Timpani A
46		Timpani A#
47		Timpani B
C3		Timpani c
48		Timpani c#
49		Timpani d
50		Timpani d#
51		Timpani e
52		Timpani f
53		
54		
55		
56		
57		Concert Cymbal 2
58		
59		Concert Cymbal 1
C4		
60	61	
62		
63		
64		
65	66	
67		
68		
69	70	
71		
C5		
72	73	
74		
75		
76		
77	78	
79		
80		
81	82	
83		
C6		
84	85	
86		
87		
88	-----	Applause

5: SOUND EFFECT	
39	High Q
40	Slap
41	Scratch Push [EXC7]
42	Scratch Pull [EXC7]
43	Sticks
44	Square Click
45	Metronome Click
46	Metronome Bell
47	Guitar sliding Finger
C3	Guitar cutting noise (down)
48	Guitar cutting noise (up)
49	String slap of double bass
50	Fl.Key Click
51	Laughing
52	Screaming
53	Punch
54	Heart Beat
55	Footsteps1
56	Footsteps2
57	Applause
58	Door Creaking
59	
C4	Door
60	Scratch
61	Wind Chimes
62	Car-Engine
63	Car-Stop
64	Car-Pass
65	Car-Crash
66	Siren
67	Train
68	Jetplane
69	Helicopter
70	Starship
71	
C5	Gun Shot
72	Machine Gun
73	Lasergun
74	Explosion
75	Dog
76	Horse-Gallop
77	Birds
78	Rain
79	Thunder
80	Wind
81	Seashore
82	Stream
83	Bubble
C6	Cat
84	
85	

Blank : same percussion instruments as the GS STANDARD.

----- : No sound.

[EXC] : will not sound simultaneously with other percussion instruments of the same number.

List of Styles

→ “Playing Along with the Auto-Accompaniment — the “Pianist” Function” (p. 20)











































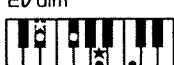



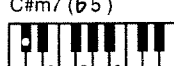
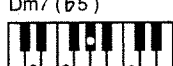

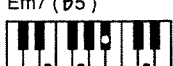
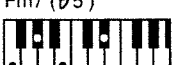

Style No.	Style
P-1	Classic 1
P-2	Slow Waltz
P-3	Pop
P-4	Slow Rock
P-5	CountryPiano
P-6	Bossa Nova
P-7	Concerto 1
P-8	Concerto 2
P-9	Concerto 3
P10	Classic 2
P11	Ballad 1
P12	Ballad 2
P13	Swing Pop
P14	Rock'n Roll
P15	Rag Time
P16	Stride Piano
P17	Swing
P18	Shuffle
P19	Boogie
P20	Slow Swing
P21	Gospel Piano
P22	Latin

List of Ways to Play Chords

● symbol: Indicates the constituent note of chords.

★ symbol: Chords shown with an “★” can be played by pressing just the key marked with the “★.”

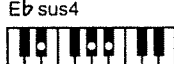
→ “Playing Along with the Auto-Accompaniment — The “Pianist” Function” (p. 20)

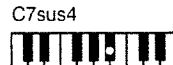
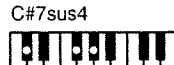
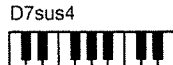
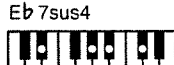
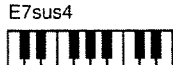
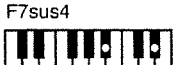
C	C#	D	E♭	E	F
					
CM7	C#M7	DM7	E♭M7	EM7	FM7
					
C7	C#7	D7	E♭7	E7	F7
					
Cm	C#m	Dm	E♭m	Em	Fm
					
Cm7	C#m7	Dm7	E♭m7	Em7	Fm7
					
Cdim	C#dim	Ddim	E♭dim	Edim	Fdim
					
Cm7 (♭5)	C#m7 (♭5)	Dm7 (♭5)	E♭m7 (♭5)	Em7 (♭5)	Fm7 (♭5)
					
Caug	C#aug	Daug	E♭aug	Eaug	Faug
					
Csus4	C#sus4	Dsus4	E♭sus4	Esus4	Fsus4
					
C7sus4	C#7sus4	D7sus4	E♭7sus4	E7sus4	F7sus4
					

List of Way to Play Chords

F#	G	A \flat	A	B \flat	B
F#M7	GM7	A \flat M7	AM7	B \flat M7	BM7
F#7	G7	A \flat 7	A7	B \flat 7	B7
F#m	Gm	A \flat m	Am	B \flat m	Bm
F#m7	Gm7	A \flat m7	Am7	B \flat m7	Bm7
F#dim	Gdim	A \flat dim	Adim	B \flat dim	Bdim
F#m7 (\flat 5)	Gm7 (\flat 5)	A \flat m7 (\flat 5)	Am7 (\flat 5)	B \flat m7 (\flat 5)	Bm7 (\flat 5)
F#aug	Gaug	A \flat aug	Aaug	B \flat aug	Baug
F#sus4	Gsus4	A \flat sus4	Asus4	B \flat sus4	Bsus4
F#7sus4	G7sus4	A \flat 7sus4	A7sus4	B \flat 7sus4	B7sus4

List of Song Titles

→ "Listening to One Song— Playback/Stop" (p.28)

No.	Composer	Song Title
1	E. Elgar	Salut D'Amour Op. 12
2	L. v. Beethoven	Piano Sonata No. 14 in C-sharp Minor, "Moonlight" 1st Movement
3	C. Debussy	"Prélude" from "Suite Bergamasque"
4	F. Schubert	Military March No. 1, Op. 51-1
5	P. Tchaikovsky	Piano Concerto No. 1 in B-flat Minor, Op. 23 1st Movement (Excerpt)
6	F. Chopin	Valse No. 6 in D-flat Major, Op. 64-1 "Petit Chien"
7	J. Brahms	Rhapsody No. 2, Op. 79
8	F. Chopin	Nocturne No. 2 in E-flat Major, Op. 9-2
9	P. Tchaikovsky	"Noel:December" from "The Seasons", Op. 37
10	W. A. Mozart	Turkisch March (Piano Sonate No. 11 in A Major, 3rd Movement "Alla Turca")
11	G. Fauré	"Berceuse" from "Dolly", Op. 56
12	A. Dvořák	Slavonic Dance No. 10, Op. 72-2
13	J. S. Bach	Menuet in G Major, BWV. Anh. 114 from "Notebook Of Anna Magdalena Bach"
14	F. Schubert	Moment musicaux No. 3, Op. 94-3
15	R. Schumann	"From Foreign Lands And People" from "Scenes From Childhood" Op. 15
16	R. Schumann	"An Weighty Event" from "Scenes From Childhood" Op. 15
17	R. Schumann	"Träumerei" from "Scenes From Childhood" Op. 15
18	L. v. Beethoven	Bagatelle "Für Elise" WoO. 59
19	J. S. Bach	Invention Three-Part (Sinfonia) No. 12 in A Major, BWV. 798
20	J. S. Bach	Invention No. 4 in D Minor, BWV. 775
21	E. Grieg	"Arietta" from "Lyric Pieces, Volume 1" Op. 12-1
22	W. A. Mozart	Piano Sonata No. 15 in C Major, 1st Movement
23	John Maul	Fly Free
24	J. Brahms, Arranged by John Maul	Hungarian Rag: Hungarian Dance No. 5 A La Ragtime
25	J. S. Bach, Arranged by John Maul	Bach's A Boppin' : Prelude No. 2 from "The Well Tempered Clavier Book2" A La Bop

* Number 4, Number 11, and Number 12 are piece for four hands.

* Number 5, Number 22, and Number 25 are piano pieces featuring orchestra accompaniment.

* No data for the music that is played will be output from MIDI OUT.

* **All rights reserved. Unauthorized use of this material for purposes other than private, personal enjoyment is a violation of applicable laws.**

John Maul

John Maul is a musician, composer and arranger having graduated from the Royal Academy of Music in London. John's work encompasses studio recordings and live performances including work with top UK Jazz artists.

His writing credits include commercial music for BBC radio and television, as well as scoring jazz and classical works.

Having been a product specialist for Roland U.K., John is now actively involved in music software composing/programming for both Roland Japan and various music publishers. Quite recently his "Musical Picture Book", a volume of original piano music encompassing all standards of musical ability, which included the piano and orchestral accompaniment data in SMF format, was published and printed.

List of Extended Functions

To access each function, press the [Function] button, then the relevant button.

Pressing the [Beat] or [Tempo] button will shift the selected function.

[Function] button -----

Using this button, call up the extended functions for these buttons.

[Piano] button -----

Extension 1: Changes the HP 535's standard pitch (p.42).

[E.Piano] button -----

Extension 2: Selects the tuning (p.40).

[Harpsi] button -----

Extension 3: Selects the keynote of the tuning (p.40).

[Vibes] button -----

Extension 4: Changes the piano's tuning curve (p.42).

[Organ] button -----

Extension 5: Assigns different functions to the sostenuto pedal (center pedal) (p.43).

[Strings] button -----

Extension 6: Sets the MIDI Send channel (p.51).

[Choir] button -----

Extension 7: Switches Local On/Off (p.52).

[GS Tones] button -----

Extension 8: Sends program changes (p.52).

[Reverb] button -----

Extension 9: Changes the reverb depth (p.42).

[Chorus] button -----

Extension 10: Changes the chorus depth (p.43).

Extension 11: Adjusts the damper pedal resonance (HP 535 only) (p.44).

[Pianist] button -----

Extension 12: Changes the volume balance between what is played on the keyboard and the automatic accompaniment (p.46)

[Split] button -----

Extension 13: Changes the split point (p.45).

[Key Touch] button -----

Extension 14: Changes the volume balance of the two tones in Dual Play (p.45).

[Metronome] button -----

Extension 15: Changes the metronome volume (p.46)

Extension 16: Changes the type of metronome sound (HP 535 only) (p.47).

Extension 17: Changes the metronome pattern (HP 535 only) (p.47).

[Song] button -----

Extension 18: Turns the beat indicator light on and off (HP 535 only) (p.48).

Extension 19: Turns the bouncing ball on and off (HP 535 only) (p.48).

Extension 20: Switches the language displayed on the screen between Japanese and English (HP 535 only) (p.48).

[Transpose] button -----

Extension 21: Transposes the keyboard (p.22).

[Play] button -----

Extension 22: Transposes the song (p.40).

[Rec] button -----

Extension 23: Sets whether or not recorded songs are sent to external MIDI devices (p.51).

* Some of the extended functions can be set by other method. Please refer to the page for each function.

Specifications

<Keyboard>

88keys (Hammer Action Mechanism)

● **Touch Sensitivity**

Preset: 3 levels, User Programs: 60 levels (HP 535)
3 levels (HP 335)

● **Keyboard Mode**

Whole
Split (Adjustable Split Point)
Dual
Pianist
Manual Drum/SFX

<Sound Source>

Comforms to GM/GS

● **Max.Polyphony**

64Voices

● **Tones**

8 Groups 263 variations
(incl.8 drum sets, 1 SFX set)

● **Temperament**

7 Types, selectable tonic

● **Stretched Tuning**

2 types

● **Master Tuning**

415.3Hz-466.2Hz (0.1Hz Step)

● **Transpose**

Key Transpose (-6-+5 Half-steps)
Playback Transpose (-6-+5 Half-steps)

● **Effects**

Reverb (10 levels)
Chorus (10 levels)
Sympathetic Resonance (10 levels)

<Arranger>

● **Music Styles**

22 Pianist Styles

● **Control**

Start/Stop
Intro/Ending

<Composer>

● **Metronome**

Beat:
2/2,0/4,2/4,3/4,4/4,5/4,6/4,7/4,3/8,6/8,9/8,12/8
Volume: 10 levels
Metronome Pattern: 11 patterns (HP 535)
Sounds: 4 types (HP 535)

● **Tracks**

3 tracks

● **Song**

1 song

● **Note Storage**

Approx. 30,000 notes

● **Tempo**

Quarter note= 20 to 250

● **Resolution**

120 ticks per quarter note

● **Control**

Song Select, Play/Stop, Rec, All song Play, Track Select, Playback Balance, Count In

<Others>

● **Rated Power Output**

30W x 2

● **Speakers**

20 cm x 2, 5 cm x 2 (HP 535)
20 cm x 2 (HP 335)

● **Display**

Beat Indicator
Large custom LCD, Bouncing Ball (HP 535)
7-segment, 3-digit LED (HP 335)

● **Language (HP 535)**

English/Japanese

● **Control**

Volume, Microphone Volume, Microphone Echo, Brilliance

● **Pedals**

Damper (half-pedal recognition)
Soft (half-pedal recognition)
Sostenuto (Function assignable)

- **Other Functions**

Panel Lock

- **Connectors**

Output jacks (Stereo/Mono)

Input jacks (Stereo/Mono)

Microphone jack (with echo)

Headphone jack x 2 (Stereo)

MIDI In connector x 2 / MIDI Out connector

Computer connector

Pedal Connector (8 pin DIN type)

- **Power supply**

AC 117 V / AC 230 V / AC 240 V

- **Power Consumption**

90 W (117 V) / 68 W (230 V) / 68 W (240 V) (HP 535)

85 W (117 V) / 68 W (230 V) / 68 W (240 V) (HP 335)

- **Cabinet finish**

Satin Mahogany (HP 535)

Simulated Rosewood (HP 335)

- **Dimensions (Including the stand)**

HP 535:

1445 (W) x 528 (D) x 920 (H) mm

56-15/16 (W) x 20-3/4 (D) x 36-1/4 (H) inches

HP 335:

1445 (W) x 525 (D) x 892 (H) mm

56-15/16 (W) x 20-11/16 (D) x 35-1/8 (H) inches

- **Weights (Including the stand)**

69.2 kg / 152 lbs 9 oz (HP 535)

60.9 kg / 134 lbs 5 oz (HP 335)

- **Accessories**

Owner's manual

Power Cord

Pianist Panel Sheet

* In the interest of product improvement, the specifications and/or appearance of this unit are subject to change without prior notice.

Glossary of Terms Used in This Manual

All Song Play

The HP 535/335 features 25 internal piano songs. Listening to these songs repeatedly played back in sequence is known as “All Song Play” (p.15).

Count In

“Count In” is a function that plays a count sound leading up to playback of songs. At times such as when you want to play along with a song, this function allows you to synchronize your timing with that of the song (p.30).

Key Transpose

As the name implies, this is a function that transposes, or “moves,” the notes played by the keys, allowing you to play in a different key without changing the keys you are playing (p.22).

Key Touch

This is the sensation of heaviness—the “touch”—of the keys when the keyboard is played. The HP 335 features three, and the HP 535 sixty levels of adjustment. (p.27)

Chorus Effect

Chorus gives the sound greater dimension, with more width and breadth (p.24).

Styles

Accompaniment patterns for the various musical genres are called “Styles” (p.20).

Stretch Tuning

When the piano tuning is compared to pitches in the equal temperament tuning, pitches in the low registers are adjusted relatively flat, and pitches in the higher registers are tuned sharper. This kind of tuning method characteristic for the piano is called “stretch tuning” (p.42).

Split

The division of the keyboard into right- and left-hand zones is referred to as “split,” and different tones can be played in the keys on different sides of the key that acts as the boundary between the right-hand part and left-hand part. (p.18)

Split Point

The particular key on the keyboard where the split occurs is called “Split point” (p.18, 45).

Tuning Curves

Graphic representations of the changes in pitch of the equally-tempered tuning versus those of actual tunings are called tuning curves (p. 42).

Dual Play

Playing with two different tones on the keyboard simultaneously is called “Dual Play” (p.17).

Tempo Mute

Defeating any tempo changes and playing back the song at one set tempo is called “Tempo Mute (p.30).

Tracks

The HP 535/335’s internal songs are divided into three parts—accompaniment, the right-hand part, and the left-hand part—which are assigned to the [R], [1], and [2] [Track] buttons. As with the [R], [1], and [2] [Track] buttons, the places where sounds are assigned are called tracks. (p.31)

Bouncing Ball

The flashing dot that moves in a semicircular pattern across the screen of the HP 535 is called a “bouncing ball” (p.10).

Pianist

The “Pianist Function” feature allows you to trigger the piano’s automatic accompaniment with simplified fingering. (p.20)

Minus One Play

The muting of some instrument parts so that you can play them yourself instead is called “Minus One Play” (p.32).

Master Tuning

When performing ensemble with other instruments, the ensemble will not sound good if the instruments are not all tuned to a common reference pitch. This tuning of all the instruments to a reference pitch, generally the pitch obtained from Middle A, is called “master tuning” (p. 42).

Mute

Preventing specified parts of the song from being played is called “muting.”

If you press the [2] button, the button’s indicator goes off, and the right-hand part assigned to the [2] button does not sound. (p.31).

Reverb Effect

This effect adds a lingering reverberation to the sound. With the reverb effect, you can get a pleasant reverberation, as if you were performing in a concert hall or similar space (p.24).

Index

A

- All Song PlayP.15
- Automatic AccompanimentP.20

B

- Bouncing Ball.....P.10,48
- Beat IndicatorP.10,48
- Beat.....P.25
- Brilliance.....P.15

C

- Chord.....P.20,60
- Chorus Effect.....P.43,43
- Computer Switch.....P.49
- Connection Jacks.....P.49
- Count InP.30
- Cursor.....P.10

D

- Delete
 - Recorded Song.....P.39
 - Recorded Track.....P.39
- DisplayP.10
- Dual Play.....P.17

E

- Ending.....P.20

F

- Four Hand Piano PieceP.32

G

- GS.....P.7
- GM.....P.7

H

- HeadphoneP.13

I

- Internal Piano Songs.....P.15,28,62
- IntroP.20

K

- Key Touch.....P.27
- Key Transpose.....P.22

L

- Language.....P.48
- Local On/Off.....P.52

M

- MetronomeP.25,46,47
- MIDI.....P.51
- Microphone.....P.13
- Minus One Play.....P.32
- Mute.....P.31

P

- Panel Lock.....P.40
- PedalP.12,43
- Pianist.....P.20
- Program Change.....P.52
- PU.....P.28

R

- Recording.....P.33
- ResonanceP.44
- Reverb Effect.....P.24,44

S

- Sound Generator.....P.7
- Split.....P.18
- Split Point.....P.18,45
- Standard Pitch.....P.42
- Styles.....P.20,59

T

- TemperamentP.40
- Tempo.....P.29
- Tempo MuteP.30
- ToneP.16
- TracksP.31
- Transpose
 - Key Transpose.....P.22
 - Playing back Songs.....P.40
- Tuning
 - Master Tuning.....P.42
 - Stretch Tuning.....P.42
- Tuning Curves.....P.42

V

- Volume
 - Master Volume.....P.15
 - Metronome Volume.....P.46
- Volume Balance
 - Between the Song (Accompaniment) and the Keyboard.....P.46
 - In Dual Play.....P.45

MEMO

HP 535/335 Errata (List of Styles)

Please make the following corrections to page 59 (List of Styles) in your HP 535/335 Owner's Manual.

Style No.	Style
P-1	Classic 1
P-2	Slow Waltz
P-3	Pop
P-4	Gospel Piano
P-5	Country Piano
P-6	Bossa Nova
P-7	Rag Time
P-8	Stride Piano
P-9	Concerto 1
P10	Classic 2
P11	Ballad 1
P12	Ballad 2
P13	Swing Pop
P14	Rock'n Roll
P15	Concerto 2
P16	Concerto 3
P17	Swing
P18	Shuffle
P19	Boogie
P20	Slow Swing
P21	Slow Rock
P22	Latin

HP 535/335 スタイル一覧 訂正

HP 535/335の取扱説明書（P.59）のスタイル一覧に誤記がありましたので、以下のように訂正いたします。

スタイル番号	スタイル
P-1	クラシック 1
P-2	スロー・ワルツ
P-3	ポップ
P-4	ゴスペル・ピアノ
P-5	カントリー・ピアノ
P-6	ボサノバ
P-7	ラグタイム
P-8	ストライド・ピアノ
P-9	コンチェルト1
P10	クラシック2
P11	バラード1
P12	バラード2
P13	スイング・ポップ
P14	ロックンロール
P15	コンチェルト2
P16	コンチェルト3
P17	スイング
P18	シャッフル
P19	ブギ
P20	スロー・スイング
P21	スロー・ロック
P22	ラテン



This product complies with the requirements of European Directives EMC 89/336/EEC and LVD 73/23/EEC.

For EU Countries

FEDERAL COMMUNICATIONS COMMISSION RADIO FREQUENCY INTERFERENCE STATEMENT

This equipment has been tested and found to comply with the limits for a Class B digital device, pursuant to Part 15 of the FCC Rules. These limits are designed to provide reasonable protection against harmful interference in a residential installation. This equipment generates, uses, and can radiate radio frequency energy and, if not installed and used in accordance with the instructions, may cause harmful interference to radio communications. However, there is no guarantee that interference will not occur in a particular installation. If this equipment does cause harmful interference to radio or television reception, which can be determined by turning the equipment off and on, the user is encouraged to try to correct the interference by one or more of the following measures:

- Reorient or relocate the receiving antenna.
- Increase the separation between the equipment and receiver.
- Connect the equipment into an outlet on a circuit different from that to which the receiver is connected.
- Consult the dealer or an experienced radio/TV technician for help.

Unauthorized changes or modification to this system can void the users authority to operate this equipment.
This equipment requires shielded interface cables in order to meet FCC class B Limit.

For the USA

NOTICE

This Class B digital apparatus meets all requirements of the Canadian Interference-Causing Equipment Regulations.

AVIS

Cet appareil numérique de la classe B respecte toutes les exigences du Règlement sur le matériel brouilleur du Canada.

For Canada

 Roland®

71015401

UPC 71015401



10981

CCC-III / CCC-III