

SOUND PLUS

EM-101

Owner's Manual

## FEATURES

- \* The Sound Plus EM-101 is an 8 voice MIDI Sound Module.
- \* By using other MIDI keyboard with the EM-101, Ensemble effect can be obtained.
- \* This has 8 tone colors for Ensemble mode (chord), and another 8 tone colors for Solo (bass and melody). Any of these 16 tone colors can be selected just by flick of a button.
- \* The EM-101's Split function allows dividing the keyboard into two sections and muting either section.
- \* This features two kinds of Dynamics; the normal dynamics that is the higher volume by the harder touch on the keyboard, and inverted dynamics that is the lower volume by harder touch.

## IMPORTANT NOTES

### Location

- Operating the EM-101 near a neon or fluorescent lamp may cause noise interference. If so, change the position or angle of the unit.
- Avoid using the EM-101 in excessive heat or humidity or where it may be affected by direct sunlight or dust.

### Power Supply

- The appropriate power supply for this unit is shown on its name plate. Please be sure that the voltage system in your country meets this.
- This unit might generate heat while operating, but there is no need to worry about it.

### Cleaning

- Use a soft cloth and mild detergent for cleaning.
- Do not use solvents such as paint thinner.

---

## CONTENTS

<b>1</b> Panel Description .....	2	6. Remote Control .....	11
<b>2</b> Connections .....	5	7. Tuning .....	11
1. Setup with the Piano Plus 300/400 .....	5	8. Damper Off .....	11
2. Setup with the Piano Plus 350/450 .....	5	<b>4</b> Setups with Audio System .....	12
3. Setup with the Piano Plus 100 .....	6	<b>5</b> Setups with other MIDI Device .....	13
<b>3</b> Operation .....	7	1. Channel Setting .....	13
1. Selecting a Tone Color .....	7	2. Program Change .....	13
2. Split Function .....	8	3. Example Setups .....	14
3. Attack Time .....	9	<b>6</b> Specifications .....	16
4. Dynamics .....	9		
5. Brilliance .....	10		

Before reading this owner's manual, please read the separate book "MIDI".

Copyright © 1985 by ROLAND CORPORATION

All rights reserved. No part of this publication may be reproduced in any form without the written permission of ROLAND CORPORATION.

# 1 Panel Descriptions

## <Front Panel>

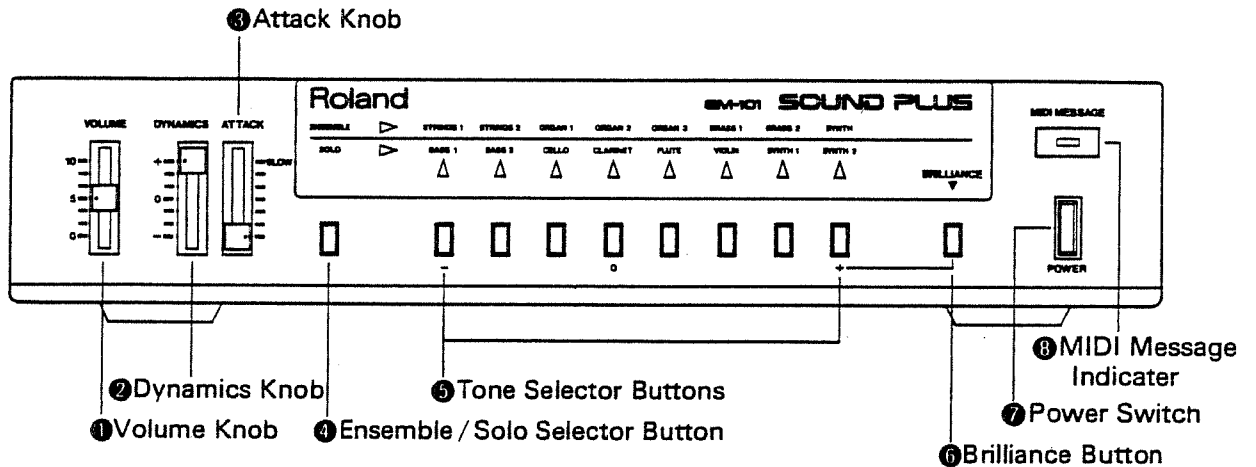

## <Rear Panel>

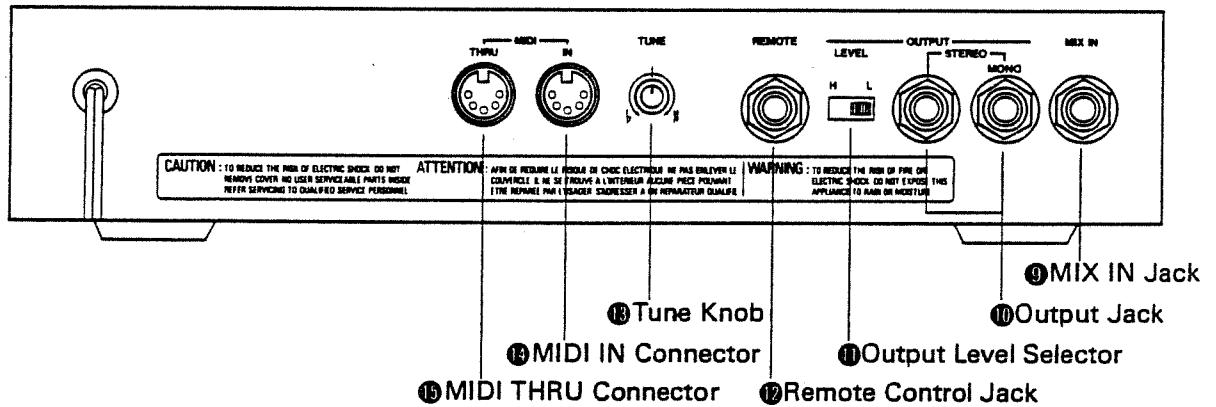

## Radio and television interference

---

**"Warning – This equipment has been verified to comply with the limits for a Class B computing device, pursuant to Subpart J, of Part 15, of FCC rules. Operation with non-certified or non-verified equipment is likely to result in interference to radio and TV reception."**

---

The equipment described in this manual generates and uses radio-frequency energy. If it is not installed and used properly, that is, in strict accordance with our instructions, it may cause interference with radio and television reception.

This equipment has been tested and found to comply with the limits for a Class B computing device in accordance with the specifications in Subpart J, of Part 15, of FCC Rules. These rules are designed to provide reasonable protection against such an interference in a residential installation.

However, there is no guarantee that the interference will not occur in a particular installation. If this equipment does cause interference to radio or television reception, which can be determined by turning the equipment on and off, the user is encouraged to try to correct the interference by the following measure:

- Disconnect other devices and their input/output cables one at a time. If the interference stops, it is caused by either the other device or its I/O cable.

These devices usually require Roland designated shielded I/O cables. For Roland devices, you can obtain the proper shielded cable from your dealer. For non Roland devices, contact the manufacturer or dealer for assistance.

If your equipment does cause interference to radio or television reception, you can try to correct the interference by using one or more of the following measures:

- Turn the TV or radio antenna until the interference stops.
- Move the equipment to one side or the other of the TV or radio.
- Move the equipment farther away from the TV or radio.
- Plug the equipment into an outlet that is on a different circuit than the TV or radio. (That is, make certain the equipment and the radio or television set are on circuits controlled by different circuit breakers or fuses.)
- Consider installing a rooftop television antenna with coaxial cable lead-in between the antenna and TV.

If necessary, you should consult your dealer or an experienced radio/television technician for additional suggestions. You may find helpful the following booklet prepared by the Federal Communications Commission:

"How to Identify and Resolve Radio-TV Interference Problems"

This booklet is available from the U.S. Government Printing Office, Washington, D.C., 20402, Stock No. 004-000-00345-4.

---

## 2 Connections

### 1. Setup with the Piano Plus 300/400

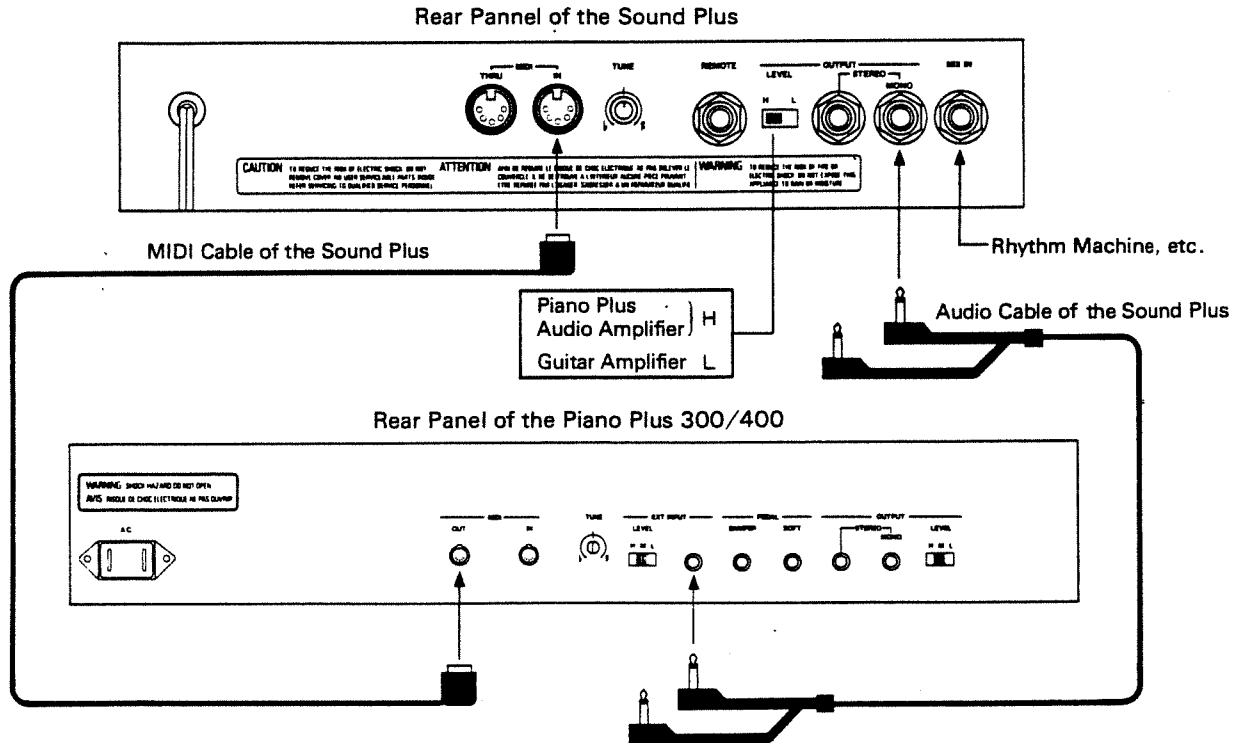

### 2. Setup with the Piano Plus 350/450

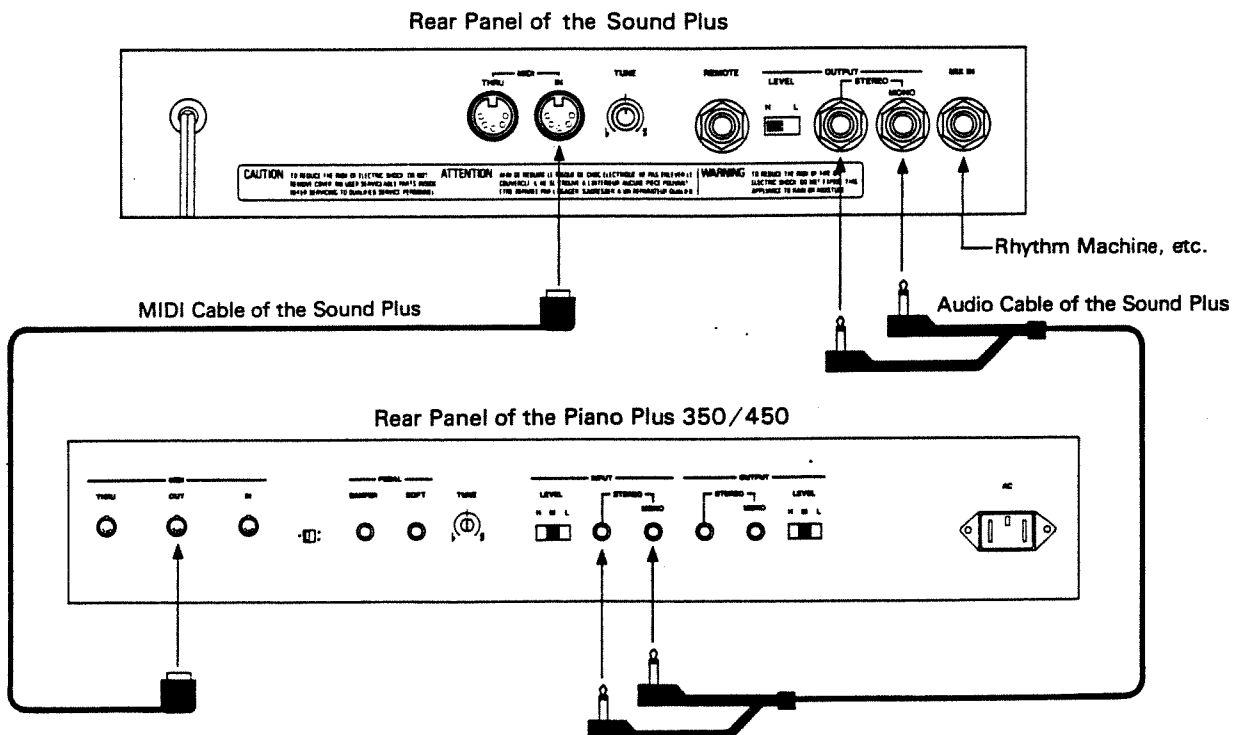

**3. Setup with the Piano Plus 100**

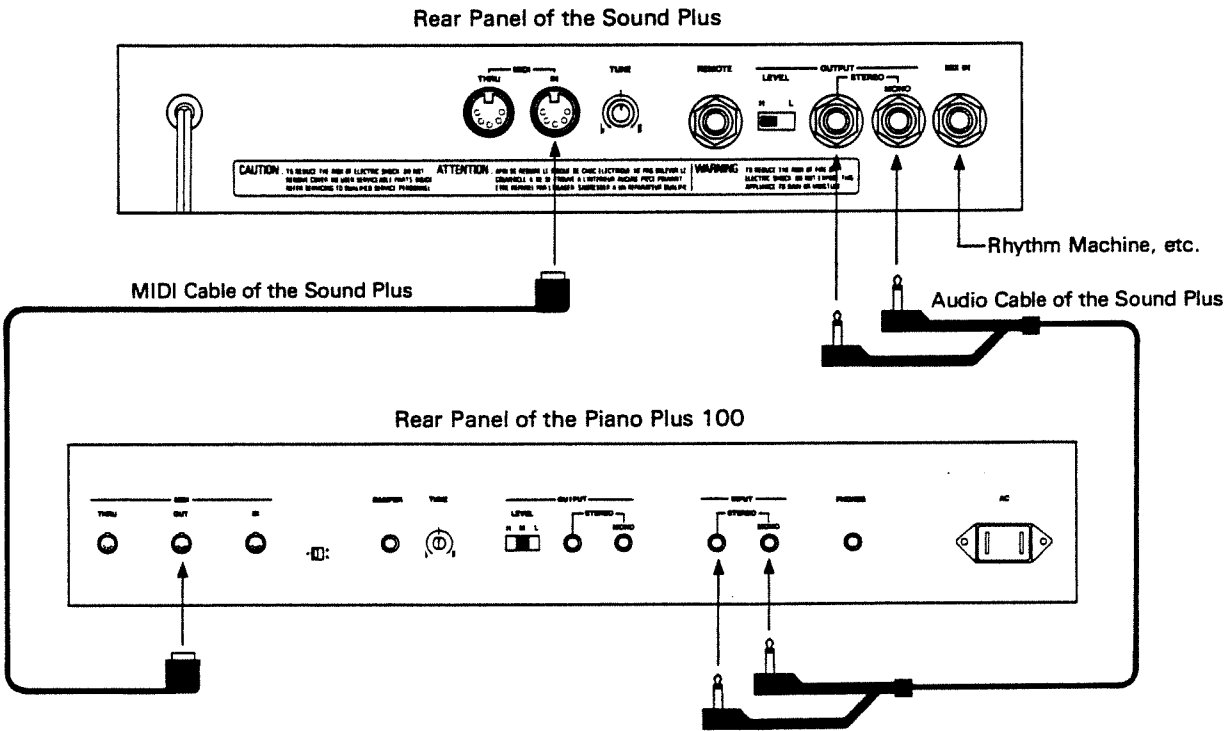

### 3 Operation

#### 1. Selecting a Tone Color

The Sound Plus has two operation modes; Ensemble (8 voices) and Solo (monophonic). In each mode, 8 tone colors are available.

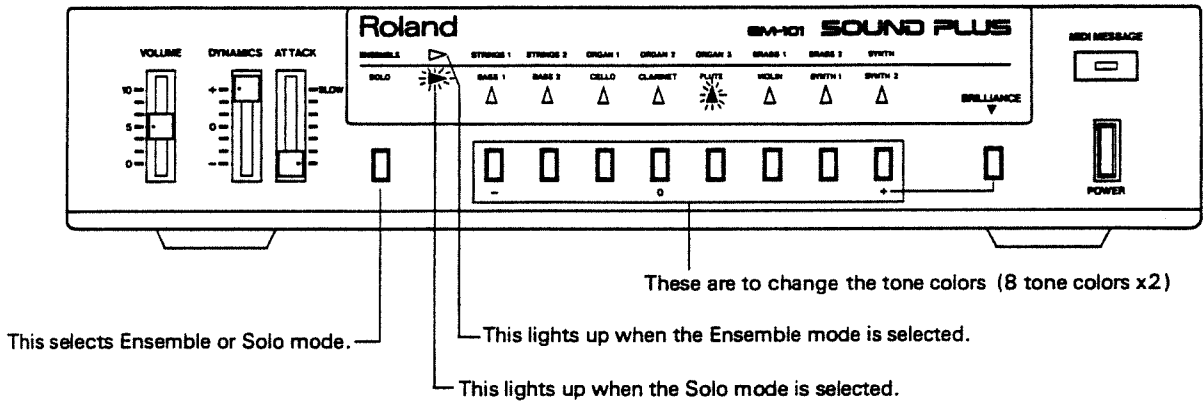

\* To select the Ensemble or the Solo mode, simply push the Ensemble/Solo Selector Button (1). To change the Tone Colors, use the Tone Selector Buttons (2). You can easily tell which operation mode or what tone color is currently selected with the glowing of the indicators.

When the Bass 1, Bass 2 or Cello is used, only the lowest note played will sound. When any other tone color is in use, the highest note will sound.

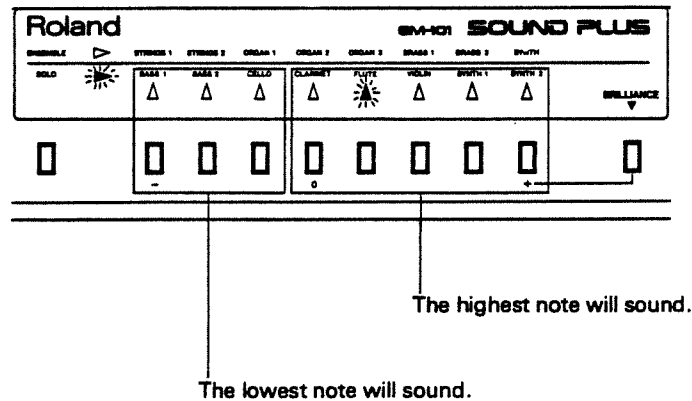

## 2. Split Function

The Split function of the Sound Plus allows dividing the keyboard into the lower and higher sections at any position of the key you like (this is called Split Point), and muting either of the lower or higher sections. That is, it is possible to mute the notes higher than the Split Point or the notes lower than that. In the Ensemble mode, you can choose which of the two sections is to be muted whatever tone color is used. In the Solo mode, however, the higher section is muted when the Bass 1, Bass 2 or Cello is used, and the lower section is muted in any other tone colors.

Three different Split Points can be set; one for all the tone colors in the Ensemble mode, one for the Bass 1, Bass 2 and Cello in the Solo mode, and one for the rest of the tone colors in the Solo mode. The Split Point you set will remain until you set a new Split Point or turn the unit off.

---

### \* Setting the Split Point in the Ensemble Mode

- ① Push the Ensemble/Solo Selector Button ④ to turn to the Ensemble mode.

The Ensemble indicator will light up.

- ② Select a tone color you like by pressing the Tone Selector Button ⑤ for about 3 seconds.

The corresponding indicator will flash.

- ③ Press any key you like, and the key will be the position of the Split Point.

The indicator of the Tone Selector Button now flashes faster.

- ④ If you wish to mute the notes lower than the set Split Point, push any key higher than the key of the Split Point. To mute the higher notes, push any lower key.

Now, the indicator stops flashing and glows steadily.

### \* Setting the Split Point in the Solo Mode

- ① Push the Ensemble/Solo Selector Button ④ to turn to the Solo mode.

The Solo indicator will light up.

- ② Select a tone color you like by pressing the Tone Selector Button ⑤ for about 3 seconds.

The corresponding indicator will flash.

- ③ Press any key you like, and the key will be the position of the Split Point.

The setting of the Split Point is completed and the indicator stops flashing.

\* This Split Point is cleared when the unit is switched off. Therefore, each time the unit is switched on, you need to set the Split Point. This also means that to cancel the Split Point at all, you just need to switch the unit off, then switch it on again.

\* To change the Split Point you have set, take the procedures ② and ③ once again.



### 3. Attack Time

Attack time is the time needed for each note to reach its maximum volume. An appropriate attack time is preset in each tone color, but it can be altered to your taste.

- \* Moving the Attack Knob ③ even slightly will cancel the current setting of the attack time, allowing you to set a new attack time. Raising the knob will make slower attack time.
- \* The attack time altered with the Attack Knob does not remain when a new tone color is selected. So, each time you change the tone colors, you need to adjust the knob if you wish to change the preset attack time to your taste.

### 4. Dynamics

The Sound Plus features two types of Dynamics; the Normal Dynamics that is the higher volume output by the harder touch on the keyboard, and Inverted Dynamics that is the lower volume by harder touch.

- \* The Dynamics Knob ② is provided to adjust the sensitivity of the dynamics. At the center click position (=0), there is no dynamics at all, that is no volume difference whether you attack the key hard or soft. Raising the knob will emphasize the sensitivity of the Normal Dynamics, and lowering the knob creates the effect of the Inverted Dynamics.

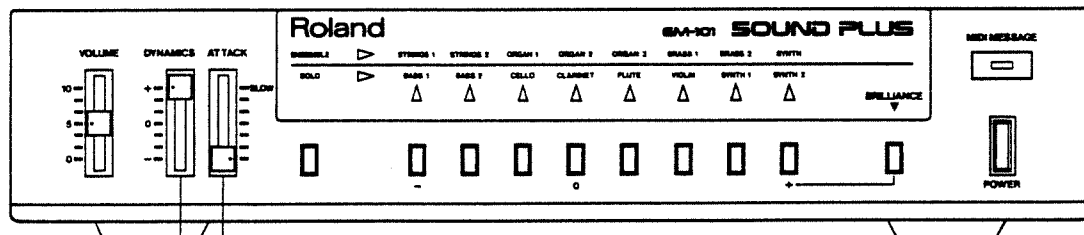

③ Attack Knob : This adjusts the attack time of each tone color.

② Dynamics Knob : This adjusts the sensitivity of the dynamics.

## 5. Brilliance

The Sound Plus features Brilliance Control that allows you to make a softer or brighter tone color. Using the Brilliance Button ④ and the Tone Selector Buttons ⑤, 8 step Brilliance Control is possible.

- ① Press the Brilliance Button ④.

The indicator that corresponds to the current brilliance will light up. (When the power is first applied, the indicator of the "0" position lights up.)

- ② While still holding the Brilliance Button down, select the brilliance you like by using the appropriate Tone Selector Button.

The button on the "-" side makes softer tone, and those on the "+" side makes brighter sound.

- ③ Release the Brilliance Button

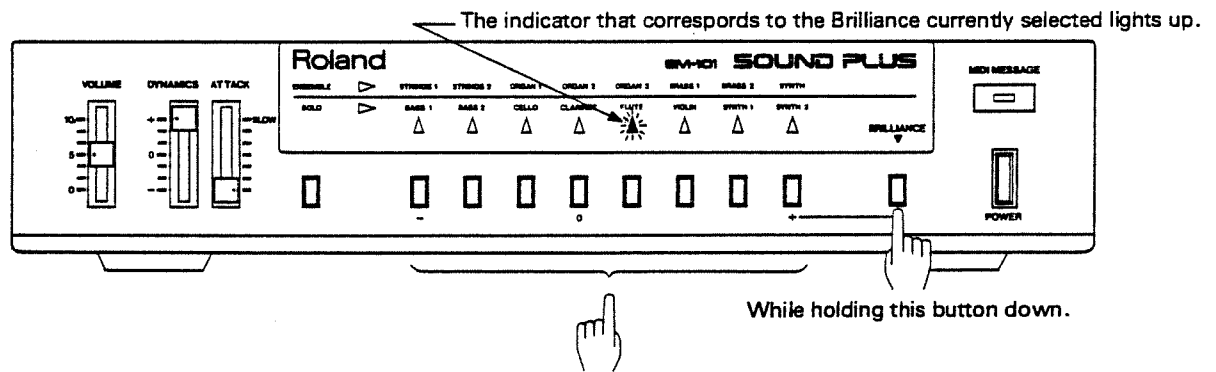

Select a new Brilliance by pushing the appropriate button.  
(The corresponding indicator will light up.)

\* The brilliance you set will remain even when a different tone color is selected.

\* The brilliance you set will remain until the unit is switched off.

## 6. Remote Control

The sound of the Sound Plus can be muted by using a pedal switch. Connect an optional pedal switch (DP-2 or DP-6) to the Remote Control Jack ⑫. Pressing the pedal switch will mute the sound of the Sound Plus, and the indicator that corresponds to the Tone Color currently in use will start flashing. Pressing the pedal once again will cancel the muting and the indicator will stop flashing and glow steadily.

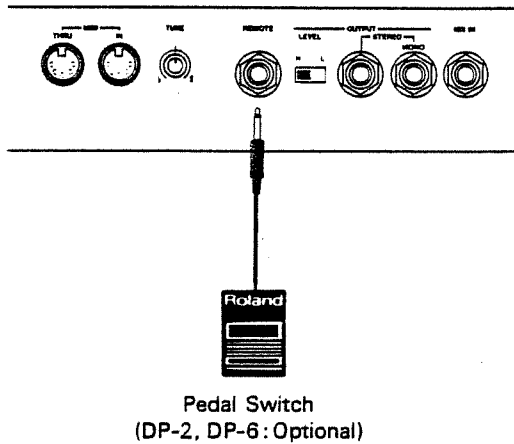

## 7. Tuning

The Tune Knob ⑬ of the Sound Plus allows tuning with other instrument.

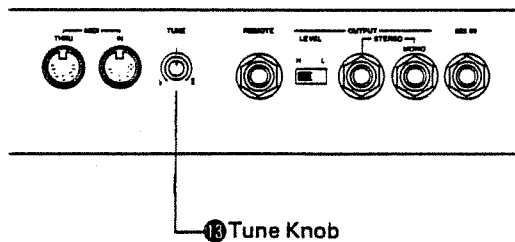

## 8. Damper Off

When the Piano Plus is set up with the Sound Plus, the damper pedal will work as a sustain pedal. That is, if you press the damper pedal while playing the Piano Plus, the sound will remain even after you release the key.

This Hold function, however, may not be always desirable. If you wish to cancel the Hold, turn the Sound Plus off, then turn it on while holding the Ensemble/Solo Selector Button ④ down.

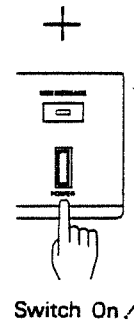
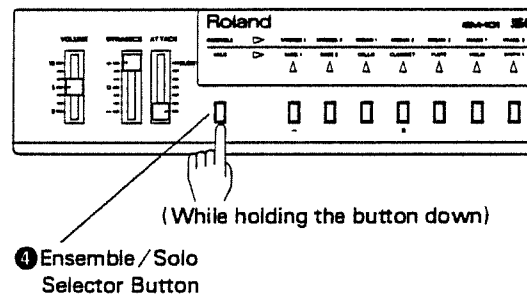

## 4 Setup with Audio System

### Example Setup 1

Using audio system only for the Sound Plus to obtain the ensemble effect.

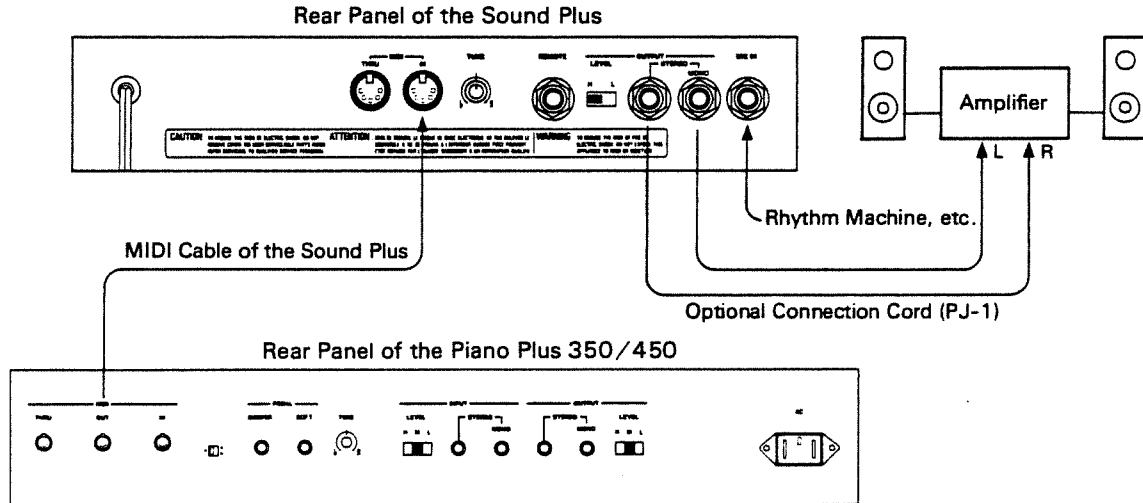

### Example Setup 2

Using audio system for amplification.

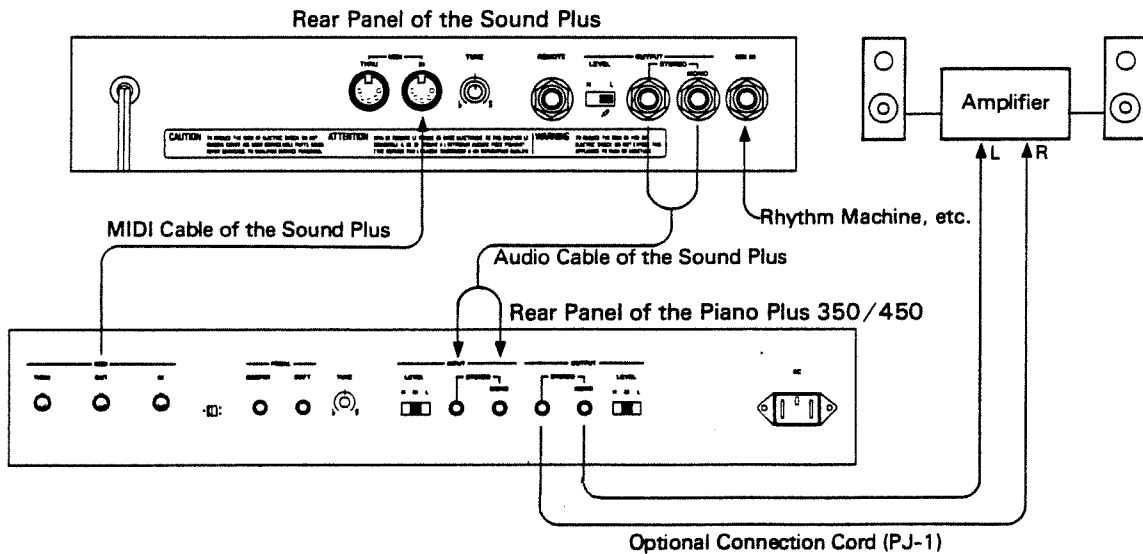

\* To mute the sound from the Piano Plus' speaker, connect headphones to the Headphones Jack.

## 5 Setup with other MIDI Device

MIDI is an international standard which allows musical communication by means of digital signals. For the details, refer to the separate volume "MIDI".

### <Receivable MIDI Messages>

- Note ON/OFF (including Velocity)
- Program Change
- Damper

### 1. Channel Setting

The Sound Plus can receive any MIDI Channel from 1 to 8. When the power is first applied, the receive channel of the Sound Plus is automatically set to Channel 1, and OMNI ON. To change the MIDI Channels, use the Tone Selector Button ③ which corresponds to channel 1 to 8.

Turn the Sound Plus on while holding down the Tone Selector Button that corresponds to the MIDI Channel number you wish to set. This operation changes OMNI ON to OMNI OFF.

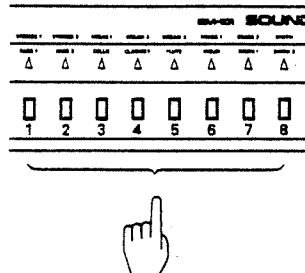

While holding the button that corresponds to the Channel number you want.

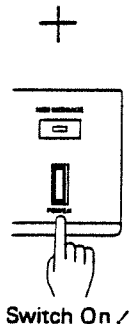

### 2. Program Change

The Tone Colors of the Sound Plus can be changed by the Program Change messages sent from the external MIDI device. The Program Change numbers 0 to 15 correspond to the 16 Tone Colors. That is, when the Sound Plus receives a Program Change number from the external MIDI device, corresponding Tone Color will be called and ready to be used, just like when you select the Tone Color by pressing the Tone Selector Button.

\* The next set of the Program Change numbers 16 through 31 works just like 0 to 15, and the following set of numbers 32 to 47 and so on.

	ENSEMBLE Tone Name		SOLO Tone Name
0	STRINGS 1	8	BASS 1
1	STRINGS 2	9	BASS 2
2	ORGAN 1	10	CELLO
3	ORGAN 2	11	CLARINET
4	ORGAN 3	12	FLUTE
5	BRASS 1	13	VIOLIN
6	BRASS 2	14	SYNTH 1
7	SYNTH	15	SYNTH 2

\* The numbers on the left of the Tone names are Program Change numbers.

### 3. Example Setups

#### ● Setup with a computer

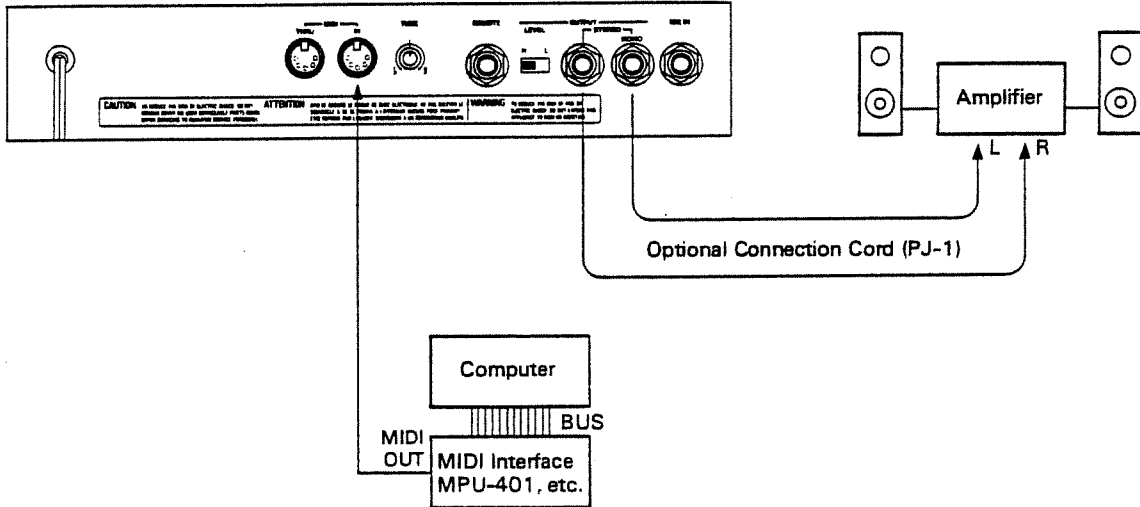

#### ● Setup with a MIDI Keyboard or sequencer

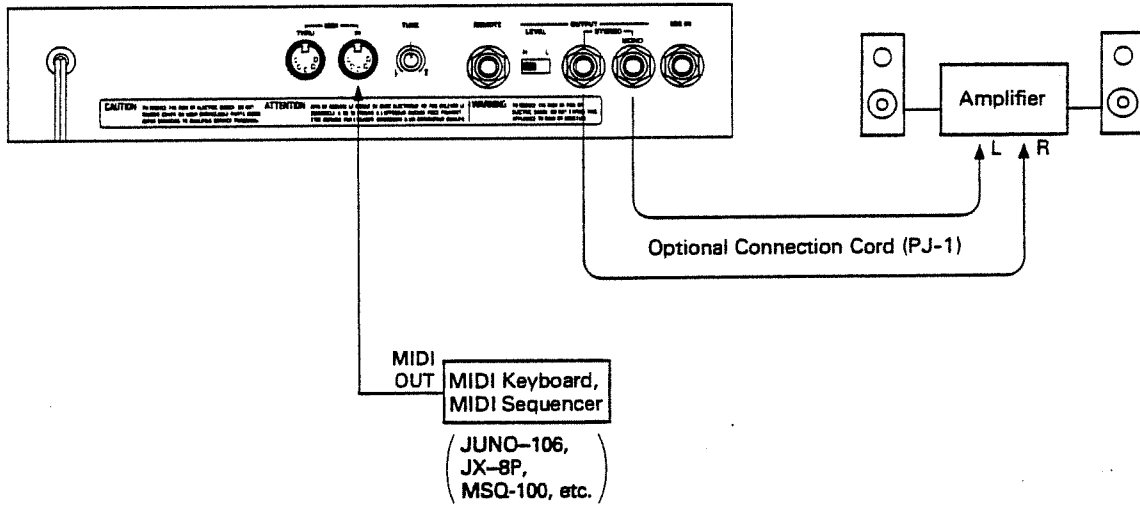

## EM-101 Sound Range

\* The following explanation is true in the condition that the range of a piano keyboard (88 keys) is used.

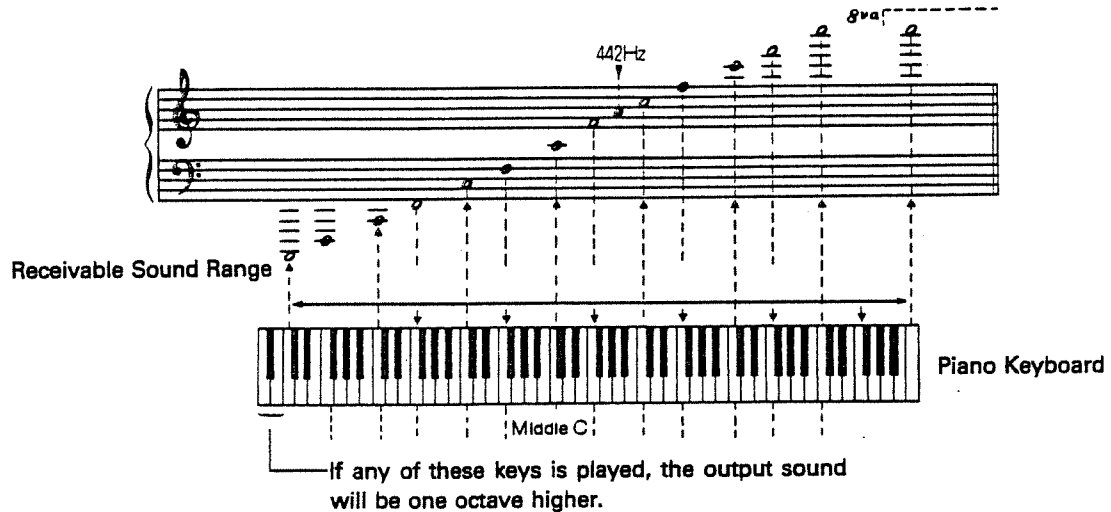

\* Each of the following Tone Colors has a preset sound range respectively.

- **SYNTH** ..... The output note is an octave higher than the key actually played.  
(Ensemble Mode)
- **STRINGS 2** ..... The output note is an octave higher than the key actually played. Within the range of the  $C_7^\sharp$  to  $C_8$ , however, the key played will sound without transposition.  
(Ensemble Mode)
- **FLUTE** .....  
(Solo Mode)
- **BASS 1, 2** ..... The output note is an octave lower than the key actually played. Within the range of the  $C_1$  to  $B_1$ , however, the key played will sound without transposition, and within  $A_0$  to  $B_0$ , one octave is transposed up, actually sounding  $A_1$  to  $B_1$ .  
(Solo Mode)

## 6 Specifications

### Preset Tone Colors

Ensemble: 8

Solo: 8

### Front Panel

Volume Knob

Dynamics Knob

Attack Knob

Ensemble/Solo Selector Button

Tone Selector Buttons (×8)

Brilliance Button

MIDI Message Indicator

Power Switch

### Rear Panel

Mix In Jack (−10 dBm)

Output Level Switch

Output Jack (L: −30 dBm, H: −10 dBm)

Remote Control Jack

Tune Knob (±35 cent)

MIDI IN Connector

MIDI THRU Connector

**Dimensions** 305(W) × 63(H) × 190(D) mm/

**Weight** 2.5 kg/

**Consumption** 117V: 9W  
220 to 240V: 10W

### Accessories

MIDI Cable

Stereo Connection Cord

## Options

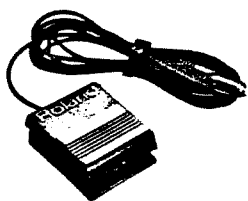

Pedal Switch DP-2

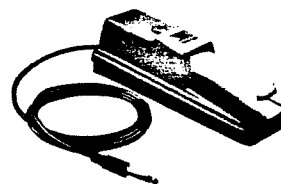

Pedal Switch DP-6



# MODEL EM-101 MIDI Implementation Chart

1. RECOGNIZED RECEIVE DATA

Status	Second	Third	Description	
1000	nnnn	0kkk kkkk	0vvv vvvv	Notes OFF, velocity ignored
1001	nnnn	0kkk kkkk	0000 0000	Notes OFF kkkkkk = 0 - 127 (24 - 100) #1
1001	nnnn	0kkk kkkk	0vvv vvvv	Notes ON kkkkkk = 0 - 127 (24 - 100) #1 vvvvvv = 1 - 127
1011	nnnn	0100 0000	01xx xxxx	Held ON #2
1011	nnnn	0100 0000	00xx xxxx	Held OFF #2
1100	nnnn	0ppp pppp		Program Change pppppp = 0 - 127 (0 - 15)
1011	nnnn	0111 1011	0000 0000	ALL NOTES OFF
1011	nnnn	0111 1100	0000 0000	OMNI OFF (ALL NOTES OFF) #3
1011	nnnn	0111 1101	0000 0000	OMNI ON (ALL NOTES OFF) #3
1011	nnnn	0111 1110	0000 0000	MONO ON (ALL NOTES OFF) #3
1011	nnnn	0111 1111	0000 0000	POLY ON (ALL NOTES OFF) #3
1111	1110			Active Sensing

Notes :

- #1 Note numbers outside of the range 24 - 100 are transposed to the nearest octave inside this range.
- #2 On power-up, Held ON/OFF (64) can be disabled by panel operation.
- #3 Mode Messages (123 - 127) are also recognized as ALL NOTES OFF. Mode Messages are recognized as follows:

	: POLY ON (127)	: MONO ON (126)	: MONO ON (126)
	: <u>        </u> = 1	: <u>        </u> = 1	: <u>        </u> < 1
OMNI OFF (124)	: OMNI = OFF	: OMNI = OFF	: OMNI = ON #
	: POLY	: POLY	: POLY
OMNI ON (125)	: OMNI = ON	: OMNI = ON	: OMNI = ON
	: POLY	: POLY	: POLY

# In this mode, only 'POLY ON' message can change the mode to OMNI OFF.

Recognized channels are as follows:

mode	voice messages	mode messages
OMNI OFF mode	basic channel only	basic channel only
OMNI ON mode	all channels	basic channel only

8-voice sound module

# MODEL EM-101 MIDI Implementation Chart

Function.....		Transmitted	Recognized	Remarks
Basic Channel	Default	×	1	
	Changed	×	1 - 8	
Mode	Default	×	Mode 1	
	Messages Altered	×	PORY, OMNI ON/OFF MONO (M≠1)→Mode1, MONO(M=1)→Mode3	
Note Number	True voice	×	0 - 127	
		*****	24 - 108	
Velocity	Note ON	×	○	v = 1 - 127
	Note OFF	×	×	
After Touch	Key's	×	×	
	Ch's	×	×	
Pitch Bender		×	×	
Control Change	64	×	○ * 1	Hold *1 : ○ or × selected when power-up
Prog Change	True #	×	○ (0-127)	
		*****	0-15	
System Exclusive		×	×	
System Common	Song Pos	×	×	
	Song Sel	×	×	
	Tune	×	×	
System Real Time	Clock	×	×	
	Commands	×	×	
Aux Messages	Local ON/OFF	×	×	(123-127)
	All Notes OFF	×	○	
	Active Sense	×	○	
	Reset	×	×	
Notes		Receiver only		

Mode 1 : OMNI ON, POLY  
Mode 3 : OMNI OFF, POLY

Mode 2 : OMNI ON, MONO  
Mode 4 : OMNI OFF, MONO

○ : Yes  
× : No

 Roland®

10131

UPC

10131



10991

EM-101

 Roland

85-8-E3-1