



Dual VCO w/Modulator

Model 9720 Assembly and Using Manual

The 9720 Dual VCO w/Modulator features two independent VCOs, each with a chromatic range of 10 octaves from 16Hz to 16kHz at a +/- 1cent pitch error. Total range of each oscillator is from 1 cycle/minute (0.017 Hz) to 100 kHz so either can be used as wide range audio source or super slow multi-waveform LFO. Temperature stability is equally extraordinary due to a novel exponential converter that provides more accurate temp tracking than conventional designs without the use of temperature compensating resistors.

Oscillator A has 5V p-p outputs for Ramp, Pulse (w/Width modulation), Triangle and Sin waveforms. The built-in Glide Processor provides slew rates from milliseconds to several seconds and a convenient toggle switch transposes down from normal audio outputs to LFO mode. The Pitch knob sets initial pitch over a 3 octave range. The Sync input provides for "Soft Synchronization" to an external audio source.

Oscillator B is very similar to Osc A but subtle differences optimize the flexibility of the pair. There are outputs for Ramp, Triangle and Pulse waveforms. A panel control for initial Pulse Width works in conjunction with the PW CV input that is normalized to the Modulator output. An auxiliary 1V/kHz Frequency Modulation input allows for complex FM timbres from just a single module.

The Modulator is an Attack/Release Envelope Generator that has a separate Trigger input for A/R envelopes and Gate input for A/R with Sustain (ASR). Attack time is adjustable from 0.5ms to 2 seconds, Release time from 1ms to 4 seconds. The Cycle switch allows self-triggering for an LFO with independently adjustable rise and fall times and a range from a cycle every few seconds to over 100Hz. The Gate and Trigger inputs also work when in Cycle mode - a Gate input turns the oscillator off and on and Trigger inputs syncs the oscillator to an external source. The front panel LED brightens and dims to indicate Modulator output.

ASSEMBLING THE 9720 DUAL VCO W/MODULATOR

Before beginning assembly, go through the manual. Look at the drawings. Feel the parts. You're naturally eager to plunge right in, but take a few deep breaths first. Check the parts supplied against the packing list on the last page of this manual.

*In some cases, notes packed with the parts will be used to call your attention to special situations. These notes may be in the "MISSING PARTS" postcard. **If parts are missing** please notify PAiA at p405.340.6300, f340.6378, or missing@paia.com.*

Notice that each step in the manual is marked with a checkoff box like this:

DESIGNATION	VALUE	COLOR CODE
() R27	100 ohm	brown-black-brown

Checking off each step as you do it may seem silly and ritualistic, but it greatly decreases the chance of omitting a step and also provides some gratification and reward as each step is completed.

Numbered figures are printed in the Illustrations Supplement in the center of this manual. These pages may be removed for easy reference during assembly.

THE CIRCUIT BOARD

The 9720 VCO is built on a double-sided circuit board. No special preparation or cleaning is necessary before assembly. The "top" of the board is the side that is printed with component designations and parts are mounted from this side. The "bottom" of the board is also called the solder side and is masked with a conformal coating to lessen the chance of solder bridges. Solder pads are tin-lead plated for ease of soldering and assembly.

TOOLS

You'll need a minimum of tools to assemble the kit - a small pair of diagonal wire cutters and pliers, screwdriver, sharp knife, ruler, soldering iron and solder.

Modern electronic components are small (in case you hadn't noticed) and values marked on the part are often difficult to see. Another handy tool for your bench will be a good magnifying glass. Also use the magnifier to examine each solder joint as it is made to make sure that it doesn't have any of the problems described in the SOLDERING section which follows.

SOLDERING

Select a soldering iron with a small tip and a power rating not more than 35 watts. Soldering guns are completely unacceptable for assembling solid state equipment because the large magnetic field they generate can damage components.

Use only a high quality 60/40 alloy rosin core solder (acid core solder is for plumbing, and silver solder is for jewelry - neither is for electronics work). A proper solder joint has just enough solder to cover the soldering pad and about 1/16-inch of lead passing through it.

There are two improper connections to beware of: Using too little solder will sometimes result in a connection which appears to be soldered when actually there is a layer of flux insulating the component lead from the solder bead. This situation can be cured by reheating the joint and applying more solder.

Too much solder may produce a conducting bridge of excess solder between adjacent pads causing a short circuit. If WAY too much solder is used it may flow through the hole and cause bridges between conductors on the component side of the board or even impede the action of mechanical components such as trimmer potentiometers. Accidental bridges can be cleaned off by holding the board upside down and flowing the excess solder off onto a clean, hot soldering iron.

Use care when mounting all components. Never force a component into place.

*Special thanks to the
beta crew -*

*Scott Lee
Mike Murphy
Johnny Klonaris
David Hillel Wilson
and me - John Simonton*

Resistors

Solder each resistor in place following the parts placement designators printed on the circuit board and the assembly drawing fig 1. Note that resistors are nonpolarized and may be mounted with either lead in either of the holes in the board. Before mounting each resistor, bend its leads so that they are at a right angle to the body of the part. Put the leads through the holes and then push the resistor firmly into place. Cinch the resistor in place by bending the leads on the solder side of the board out to an angle of about 45 degrees. Solder both ends of each resistor in place as you install it. Clip each lead flush with the solder joint and save a few of the clippings for use in later steps.

The 9720 VCO uses 1% film resistors in precision circuitry and 5% carbon film resistors in non-critical locations. Not all resistors are mounted on the circuit board, some will be "left over" when the board is finished and will be installed later in the assembly procedure.

First we'll install the 5% resistors. These resistors are identified by their 4 color bands. A tip: If you can't find the location for a resistor, go on to the next one and come back. **DO NOT CHECK OFF A PART UNTIL IT IS INSTALLED AND SOLDERED.**

DESIGNATION VALUE COLOR CODE A-B-C

() R21 1.5m brown-green-green
() R43 1.5m brown-green-green
() R97 1.5m brown-green-green

listed below: 100k brown-black-yellow
() R3 () R6 () R10 () R12
() R35 () R38 () R89 () R90
() R94 () R95 () R96

listed below: 10k brown-black-orange
() R34 () R47 () R56 () R68
() R78

() R63 10meg brown-black-blue
() R73 10meg brown-black-blue

listed below: 120k brown-red-yellow
() R7 () R18 () R45 () R77
() R79

Silver or Gold
(disregard)

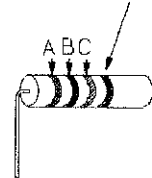

5% Resistors have
4 color bands

DESIGNATION VALUE COLOR CODE A-B-C

() R19	12k	brown-red-orange
() R54	12k	brown-red-orange
() R61	12k	brown-red-orange
() R66	1500	brown-green-red
() R75	1500	brown-green-red
() R91	150k	brown-green-yellow
() R76	15k	brown-green-orange
() R60	180k	brown-grey-yellow
listed below:	18k	brown-grey-orange
() R4	() R11	() R81 () R86
() R31	1k	brown-black-red
() R57	1k	brown-black-red
() R1	22	red-red-black
listed below:	220	red-red-brown
() R24	() R46	() R50 () R88
listed below:	2200	red-red-red
() R13	() R15	() R22 () R32
() R65	() R74	() R83 () R84
() R100	220k	red-red-yellow
() R102	220k	red-red-yellow
() R106	220k	red-red-yellow
() R25	2400	red-yellow-red
() R52	2400	red-yellow-red
listed below:	27k	red-violet-orange
() R51	() R62	() R67 () R72
listed below:	3300	orange-orange-red
() R26	() R33	() R49 () R53
() R70	() R99	() R104
() R9	33k	orange-orange-orange
() R85	33k	orange-orange-orange
() R17	390k	orange-white-yellow
() R41	390k	orange-white-yellow
() R28	39k	orange-white-orange
() R55	39k	orange-white-orange
() R30	470k	yellow-violet-yellow
listed below:	47k	yellow-violet-orange
() R39	() R69	() R92 () R105
() R2	56	green-blue-black

DESIGNATION VALUE COLOR CODE A-B-C

listed below: 5600 green-blue-red
 () R36 () R37 () R64 () R82

listed below: 56k green-blue-orange
 () R20 () R23 () R44 () R48
 () R71 () R93

() R29 750 violet-green-brown
 () R98 82k grey-red-orange
 () R101 82k grey-red-orange

listed below 91k white-brown-orange
 () R8 () R59 () R80 () R103

1% FILM RESISTORS

The 1% metal film resistors are identified by their 5 color bands.

DESIGNATION VALUE COLOR CODE A-B-C-D

listed below: 100k 1% brown-black-black-orange
 () R14 () R16 () R40 () R42

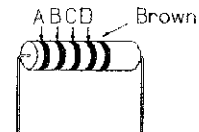

Disk and Polystyrene Capacitors

Many of the capacitors used in the 9720 are nonpolarized Ceramic Disk and Polystyrene types. For each of these, either lead can go in either of the holes in the circuit board. The leads of the Ceramic Disk capacitors are already parallel to each other but still may need to be bent slightly to match the spacing of the circuit board holes. The leads of the Polystyrene capacitors will need to bend down prior to installation and may be further apart than the spacing of the circuit board holes. Like the resistors, insert the leads of these parts through the holes in the board and push the part against the circuit board as far as it wants to go. Don't force it, it's OK if it sits a little off the board.

1% Resistors have 5 color bands

Capacitors are often marked with obscure codes that indicate their values. The 3 digit number that specifies value may be preceded or followed by letters indicating such things as tolerance. If you get confused about which capacitors are which, it may help to group them by same type and check them against quantities on the packing list at the end of this manual.

Ceramic Disk Capacitors

DESIGNATION VALUE MARKING

() C13	0.001uF	102	
() C17	0.001uF	102	
listed below: 0.01uF		103	
() C3	() C5	() C9	() C15
() C20	() C23		

listed below: 15pF		15	
() C7	() C8	() C10	() C14
() C18	() C19	() C21	

Polystyrene Capacitors

DESIGNATION VALUE MARKING

() C11	4700pF	4700J
() C16	4700pF	4700J

Capacitors
Disk Polystyrene

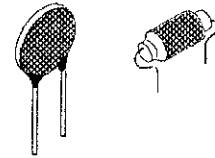

Electrolytic Capacitors

The remaining capacitors are electrolytic types. Unlike the previous components, electrolytic capacitors are polarized and the leads are not interchangeable. Leads are marked "+" and/or "-" and the "+" lead must go through the "+" hole in the circuit board. Frequently the positive lead of the capacitor is significantly longer than the negative lead. Usually the Negative lead of the capacitor is marked rather than the positive. It naturally goes through the unmarked hole.

Capacitors supplied with specific kits may have a higher Voltage (V) rating than the minimum specified below.

DESIGNATION VALUE

() C12	1uF / 15V.
() C22	1uF / 15V.
() C1	470uF / 25V.
() C2	470uF / 25V.
() C4	4.7uF / 15V
() C6	4.7uF / 15V

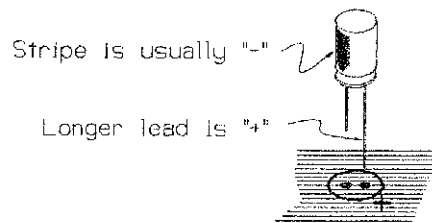

Diodes

Like the Electrolytic Capacitors, diodes are polarized and must be installed so that the lead on the banded end of the part corresponds to the banded end of the designator on the circuit board. Bend the leads so they are at right angles to the body of the part and insert them through the holes provided in the circuit board.

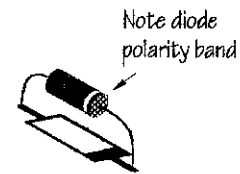

Diodes are also somewhat heat sensitive so the soldering operation should be done as quickly as possible.

DESIGNATION TYPE

listed below: 1N4148 Silicon Diode

<input type="checkbox"/> D1	<input type="checkbox"/> D2	<input type="checkbox"/> D3	<input type="checkbox"/> D4
<input type="checkbox"/> D5	<input type="checkbox"/> D6	<input type="checkbox"/> D7	<input type="checkbox"/> D8
<input type="checkbox"/> D9	<input type="checkbox"/> D10	<input type="checkbox"/> D11	<input type="checkbox"/> D12
<input type="checkbox"/> D13	<input type="checkbox"/> D14	<input type="checkbox"/> D15	<input type="checkbox"/> D16
<input type="checkbox"/> D17	<input type="checkbox"/> D18		

Transistors

Install the transistors by inserting their three leads through the holes provided for them in the circuit board. Note that the transistors are polarized by the flat side of the case. When the transistors are properly installed this flat will align with the corresponding mark on the circuit board legending.

Four of the transistors are supplied as pairs that have been specially selected to have matching characteristics and will be packed together. Keeping these pairs together is important for optimum circuit performance.

Notice that two different types of transistors (2N3904 and 2N3906) are used. The type will be written on the body of the part.

DESIGNATION TYPE

listed below: 2N3906 PNP Silicon Transistor

<input type="checkbox"/> Q2/Q3	<input type="checkbox"/> Q8/Q9	matched pairs
<input type="checkbox"/> Q1		not matched
<input type="checkbox"/> Q4		not matched

listed below: 2N3904 NPN Si Transistors not matched

<input type="checkbox"/> Q5	<input type="checkbox"/> Q6	<input type="checkbox"/> Q7	<input type="checkbox"/> Q10
-----------------------------	-----------------------------	-----------------------------	------------------------------

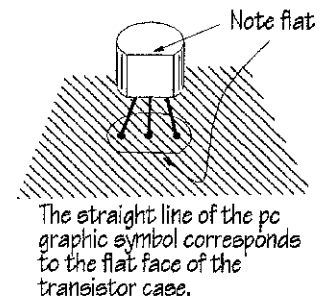

Trimmer Potentiometers

Mount the four trimmer potentiometers by inserting their three pins into the holes provided. Press them down until the "shoulders" of the solder pins are resting on the surface of the circuit board. Solder all three pins on each part.

CAUTION: Too much solder here may flow through and cause problems

DESIGNATION	VALUE	MARKING
() R5	10k	Trimmer
() R87	10k	Trimmer
() R27	1k	Trimmer
() R58	1k	Trimmer

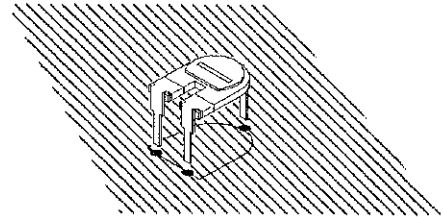

Integrated Circuits

Of all the parts, the ICs are the most easily damaged and should be treated with some respect. In particular, they may be destroyed by discharges of static electricity. Modern ICs are not nearly as sensitive to this kind of damage as were earlier versions, but it is still good practice to handle these parts as little as possible. Also good practice: don't wear nylon during assembly. Don't shuffle around on the carpet immediately before assembly (or if you do, touch a lamp or something to make sure you're discharged). Don't be intimidated. It's rare for parts to be damaged this way.

ICs are polarized in one or both of two ways; A dot formed into the case of the IC corresponding to pin 1 or a semicircular notch that indicates the end of the package with pin 1. Take care that this polarizing indicator corresponds to the similar indicator on the circuit board graphics.

The pins of the ICs may be splayed somewhat and not match the holes in the circuit board exactly. Carefully re-form the leads if necessary so that they are at right angles to the part.

Solder each IC in place as it is installed by initially soldering two pins in diagonal corners of the pattern. Make sure that the part is seated firmly against the circuit board by pressing it down while re-melting the solder joint at first one corner, then the other. Finally, solder the remaining connections.

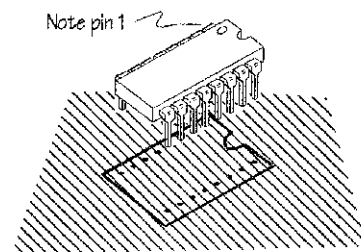

DESIGNATION	PART NO.	DESCRIPTION
() IC4	LM13700	Dual Operational Transconductance Amp
() IC5	LM13700	Dual OTA
() IC3	TL084	Quad J-FET OpAmp
() IC7	TL084	Quad J-FET OpAmp
() IC8	LM324	Quad OpAmp
() IC6	LM339	Quad Comparator

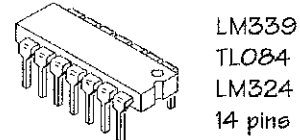

Voltage Regulators

The voltage regulators are polarized and must be mounted so that their tabs correspond to the tab markings on the circuit board graphics. Solder all three leads and clip any excess off flush with the solder joint.

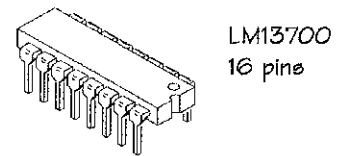

() IC1	7912	-12V Voltage Regulator
() IC2	7812	+12V Voltage Regulator

LEDs

LEDs are polarized by the flat in the collar at the base of part. When properly installed, this flat will align with the corresponding flat in the LED symbol printed on the circuit board.

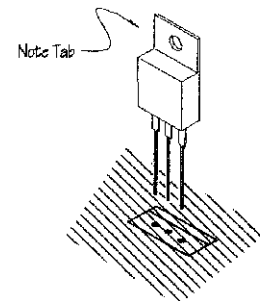

When the 9730 is installed behind its front panel, the LED will engage the holes in the front panel and be supported by its leads.

Cut a 1/2" length of the small diameter sleeving supplied over the lead opposite the polarizing flat. Push the two leads through the holes in the circuit board; if the sleeving is too long to allow soldering trim it slightly. When satisfied with the spacer length, confirm the orientation of the LED and solder both leads. Trim the longer lead off flush with the solder joint - the shorter lead may need no trimming.

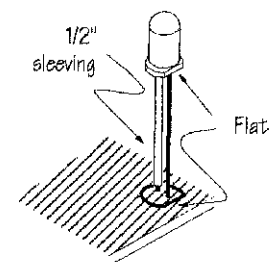

DESIGNATION TYPE

() LED1	Red LED
----------	---------

Use 1/2" length of the small diameter sleeving as a spacer and insulator on the LED.

"Flying" Wires

(i.e. those which go from circuit board to panel mounted parts.)

In the following steps, wires will be soldered to the 9720 board which in later steps will be connected to the front panel controls and switches. At each step, cut a piece of wire to the specified length and strip 1/4" of insulation from each end. Twist the exposed wire strands together and "tin" them by melting a small amount of solder into the strands. This will make soldering easier when the wires are installed and prevents fraying of the wire strands when they are pushed through the holes. Solder each connection as it is made and clip any excess wire from the solder side of the board.

Note: If you also have the 9720frm FracRak Accessory kit do not use the wire from that kit in these steps. 9720frm wires are already cut to length for use with the power connector.

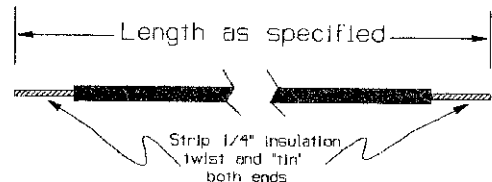

PC POINT	WIRE LENGTH	PC POINT	WIRE LENGTH
() "A"	7-1/4"	() "B"	7-3/4"
() "C"	7-1/2"	() "D"	7-1/2"
() "E"	7"	() "F"	7"
() "H"	6-1/4"	() "I"	6"
() "J"	6"	() "K"	7-3/4"
() "L"	7-1/4"	() "M"	7-1/4"
() "N"	7-1/4"	() "O"	8"
() "P"	8"	() "R"	7"
() "S"	8"	() "T"	6-1/2"
() "U"	6-1/4"	() "V"	6-1/4"
() "W"	7"	() "X"	6"
() "Y"	5-3/4"	() "Z"	5-3/4"
() "AA"	6"	() "AB"	6-3/4"
() "AC"	5"	() "AD"	7-3/4"
() "AE"	7-1/2"	() "AF"	8"

Be very careful not to nick wire strands while stripping insulation. An inexpensive wire stripper is a good tool to have here. When soldering the wire to the board do not allow the insulation to slip through the hole - make sure you are soldering to wire.

This completes assembly of the 9720 circuit board. Admire your work for a few minutes then take a break. When you come back, admire your work again but this time be critical. It would be a good time to double check the orientation of polarized parts and that the right resistors and capacitors are in the right places. Examine the solder joints. On the component side make sure excess solder has not flowed through the hole. On the solder side, are they all nice and shiny? If they have the "lumpy" granular look that indicates a cold joint, reheat them. Solder bridges are less likely with a solder masked circuit board but they can still happen. If you're not sure about a bridge refer to the foil patterns in fig 1.

Front Panel Controls

Now we will put the circuit board aside temporarily and mount the controls, switches and jacks on the front panel. If you have the optional panel available from PAiA, you will be installing these parts at the locations shown in fig 2.

- () Using the nuts supplied with them, mount the eighteen 1/8" Closed Circuit Phone Jacks as shown in fig 2. Note that while both Mono and Closed Circuit Jacks are shown in the schematic (Fig 7), CC jacks are used for both types. Orient the jacks as shown in fig 3 before fully tightening the nuts to secure them.

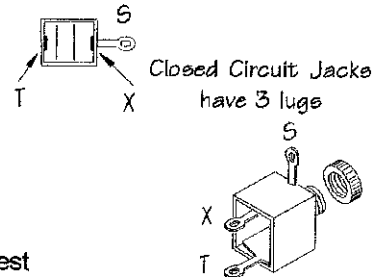

It will be easier to do the ground wiring of J11-J18 before the rest of the panel controls are mounted.

- () Cut a 4-1/4" length of the bare wire supplied and pass it through the holes in the "S" lugs of J11 and J17 (lift these two lugs away from the panel and twist them so the wire can pass through). Lift the "S" lug of J18 and connect the end of the wire extending beyond J17 to J-18 lug S.

At this point there should be a stub of wire about 3/4" long extending beyond the "S" lug of J11 which will be connected in later steps.

- () Solder the connections between the wire and J11 and J17 before connecting the "S" lugs of J12-J16 to the wire by bending them up until they touch the wire then soldering the two together. DO NOT SOLDER the connection at J18.

- () Using the flat washers and nuts supplied, mount the seven potentiometers to the panel as shown in fig 2. Note that four different values are used so be careful that the correct value is placed in the correct location. Value is stamped or printed on the body of the part. Orient the pots with the solder lugs as shown in fig 3 and fully tighten the nuts to secure them. **A tip: marking the part number (e.g. R200) on the back of the pots with an indelible pen will make later wiring easier and less prone to error.**

Bend or remove this tab so that the pot will seat flush against the front panel.

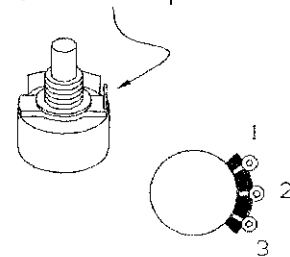

- () Using the nuts supplied with them, mount the two miniature toggle switches as shown in fig 2. Orient the switches as shown in fig 3 and fully tighten the nut to secure it. The switch is symmetrical so whichever soldering lug is on the left or up is #1.

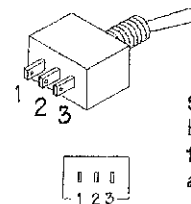

SFDT switches may be supplied even though only SPST are required.

Now we'll continue wiring of the front panel parts as shown in fig 3. First, notice that individual solder lugs are identified by part number and lug number. For example, R200-1 means the lug labeled "1" of the Potentiometer R200.

Also, this convention will be followed in these steps: Do not solder a connection to a lug until told to do so with an instruction such as (s2), which means that at that point there will be two wires on the lug in question. If there are not the number of wires specified at the lug when you get ready to solder, recheck to see what has gone wrong. Connections which should not be soldered yet will be marked (ns) for NO SOLDER. On these unsoldered connections simply push the end of the wire through the lug and crimp it back to mechanically secure it.

- () Connect the free end of the solid wire extending beyond J11-S to R203-1 (ns).
- () Cut a 3-3/4" length of bare wire and pass it through the holes in the "S" lugs of J1 and J9. DO NOT SOLDER these two connections. Bend the "S" lugs of J2-J8 up to meet the wire and solder these seven connections.

In the following steps cut a piece of bare wire to the length indicated and use it to connect the component lugs specified. Route the wires as shown in Fig 3 and push them down close to the front panel so they will not short against the lugs of switches and jacks and future wiring. The "clipping" length means that a resistor or capacitor lead clipped earlier should be used.

LENGTH	FROM	TO
() clipping	R201-2 (s1)	R201-3 (ns)
() clipping	R200-2 (s1)	R200-3 (ns)
() clipping	R205-2 (s1)	R205-3 (ns)
() 3-1/4"	S2-1 (s1)	R204-1 (ns)
() 2"	R204-1 (ns)	R202-1 (ns)
() 3/4"	R206-1 (ns)	J10-S (ns)
() 3/4"	J7-X (ns)	S1-2 (ns)

Many point-to-point panel connections are made using the insulated stranded wire. For each of these cut piece of wire to the length specified, strip 1/4" of insulation from each end and twist and tin the exposed strands. Proceed by columns.

LENGTH	FROM	TO	LENGTH	FROM	TO
() 4"	R203-1 (ns)	J1-S (ns)	() 3-3/4"	R203-3 (s1)	R204-3 (s2)
() 2"	R204-3 (ns)	R206-3 (ns)	() 1-3/4"	R204-1 (s3)	R206-1 (s2)
() 1-1/2"	J18-T (s1)	R202-2 (ns)	() 4"	R202-2 (s2)	J10-X (s1)
() 1-1/2"	J9-S (s2)	S1-2 (s2)	() 1-3/4"	J18-S (s2)	R202-1 (s2)
			() 2-1/2"	J7-X (s2)	J4-X (s1)

The resistors and capacitor not used during circuit board assembly will now mount directly on the lugs of panel parts (see fig 3).

- () Cut the leads of the remaining 100k ohm 1% resistor (brown-blk-blk-orange) to a length of 1/2". Connect one lead to J1-S (s3) and the other to J1-T (ns). This is R209.
- () Cut the leads of the .001uF ceramic disk capacitor (marked 102) to a length of 3/8". Connect one lead to J8-T (s1) and the other to J9-T (ns). This is C24.
- () Locate the 750 ohm 5% resistor (violet-green-brown). Cut two 5/8" lengths of the small sleeving supplied and slip one over each resistor lead. Trim the leads so that 1/4" extends beyond the sleeving. Use this part as R207 to make the connection from R200-1 (s1) to R201-1 (ns).
- () Similarly insulate the leads of the 39k ohm 5% resistor (orange-white-orange). Use this part as R208 to make the connection from J3-X (s1) to J10-S (s2).

This completes the wiring between parts on the front panel.

Before going further, make sure that the bare wire is dressed down against the panel and not in danger of shorting to unintended solder lugs. Dress the insulated wires down also - they need not be close to the panel but should not loop out away from the assembly.

A few connections will be made between the circuit board and front panel before the two are fastened together. These connections will be close to components on the circuit board when it is attached to the panel so sections of clear tubing are used for insulating sleeves. Cut a 3/8" long piece of large tubing from the length supplied and slip it over the wire before making the connection. When the solder joint has cooled, slide the tubing down over the lug (see fig 4).

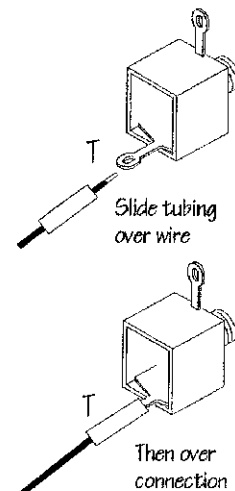

FROM	TO	FROM	TO
() "W"	J11-T (s1)	() "F"	J15-T (s1)
() "V"	J12-T (s1)	() "S"	J16-T (s1)
() "AB"	J13-T (s1)	() "D"	J17-T (s1)
() "L"	J14-T (s1)		

Now it's time to use the #4 hardware and "L" brackets to attach the front panel to the circuit board. Before beginning, take a good look at the "L" Brackets and note that one of the holes is threaded and the other is not.

- () Attach the "L" brackets to the circuit board using two 4-40 X 1/4" Machine Screws through the board from the solder side and then through the **unthreaded** holes in the "L" brackets. Secure each with a #4 nut. Some adjustment will be required when the panel is attached, so do not fully tighten the screws.
- () Bend the LED over so that it engages the hole provided for it in the front panel as shown in fig 2. Attach the circuit board to the front panel by passing 4-40 X 1/4" Machine Screws through the panel from the front and into the **threaded** hole in the "L" brackets. When satisfied with the alignment of panel, LED and circuit board, fully tighten the hardware.

Finish panel assembly by connecting the remaining wires from the circuit board to the jacks and controls on the front panel. Solder as indicated. (See Fig 4)

FROM	TO	FROM	TO
() "B"	J7-T (s1)	() "C"	R203-1 (s3)
() "I"	R203-2 (s1)	() "K"	R201-3 (s2)
() "M"	R200-3 (s2)	() "N"	S1-1 (s1)
() "AA"	R206-2 (s1)	() "AD"	R202-3 (s1)

See Fig 5 for an illustration of the rest of the wiring:

() "R"	R204-2 (s1)	() "H"	J2-T (s1)
() "A"	R206-3 (s2)	() "U"	J3-T (s1)
() "AC"	S2-2 (s1)	() "E"	J4-T (s1)
() "AE"	R201-1 (s2)	() "P"	J5-T (s1)
() "J"	R205-1 (s1)	() "O"	J6-T (s1)
() "Y"	R205-3 (s2)	() "AF"	J9-T (s2)
() "T"	J10-T (s1)	() "X"	J5-X (s1)
() "Z"	J1-T (s2)		

POWER CABLE AND CONNECTOR

If you have the 9720frm accessory kit, locate the power connector housing and pins. You will be connecting wires to the pins and will need to be able to hold the pin steady while soldering. Using an old-fashioned wooden clothes pin as a vise is a good choice, but try to find one these days. A pair of needle-nose pliers with a rubber band around the handle to hold the jaws closed works but too heavy a rubber band can apply too much pressure and crush the pin.

Proceed with assembly of the power connector as follows:

- () Prepare the four 16" lengths of stranded insulated wire supplied with the 9720frm kit by stripping 1/4" of insulation from one end of each wire only. Twist and tin the exposed wire strands then clip off the tinned end so that a 1/8" stub remains.
- () Solder one of the power connector pins to the end of each wire. Steady the pin as discussed above and lay the tinned end of the wire in the "trough" of the pin as shown in the illustration. Solder the connection by holding the soldering iron against the wire and pin until the solder remelts. You should not need to add more solder. Allow the joint to cool and test it by wiggling the wire to make sure the joint is firm. Do not wrap the "wings" of the pin around the wire.
- () Slide the power pins into the connector body. Note the orientation of the pin as shown in the illustration. Slide the pin in until the catch on the back of the pin engages the slot in the connector body and you feel the "snap" as it locks in place. Give the wire another good tug to test the solder joint and that the pin is latched in place.

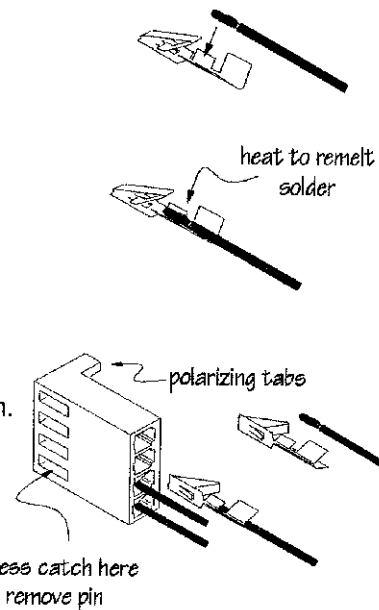

If the wire comes loose, don't panic. The pins can be released from the connector by using a knife blade or small tool to reach through the slots in the connector body to press down the catch.

- () Prepare the free ends of the wires by stripping 1/4" of insulation from the end and twisting the exposed wire strands tightly. Do not tin these wires. Push each wire through the "+", "G", "SG" and "-" holes in the board as shown in the illustration (note the polarizing tabs on the connector body) and check to make sure there are no stray wire strands that did not make it through the hole before soldering in place. Clip off any excess on the solder side of the board.

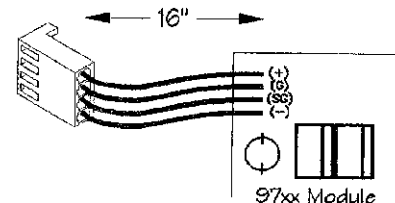

Use the 3 nylon wire ties to group the four wires together by placing one in the middle and the other two halfway to either end. Cinch the ties tight and clip off the excess.

- () Locate the power connector header and install it in the appropriate location on the FracRak format power supply you will be using. Note the orientation of the locking tab shown in the illustration. Push the 4 pins through the board but solder one pin only. Examine the header to see that it is seated flush on the board and if not, remelt the single joint and push the connector fully into place. When satisfied, solder the remaining three pins.

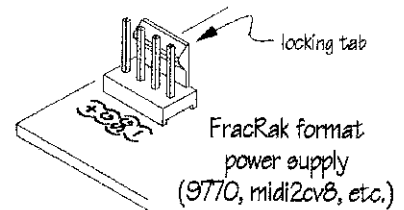

- () Turn the control shafts of all the potentiometers fully counter clockwise and mount each knob in turn by placing it on the shaft and aligning the pointer with CCW end of the panel graphic. Tighten the set screw slightly and rotate the control back and forth to see that its range of rotation is centered with respect to the panel graphic. Loosen the screw and realign the knob as needed and fully tighten when done.

The moment of truth is at hand, the next step will be to power up the module and start testing. This is an excellent time to take another break, stretch and think about something else for a while. When you come back take the time to do a final check. The flying wires to the panel aren't bundled with wire ties yet, and we'll leave them that way for now, so move them around a little to check the connections. Inspect the wiring on the panel and make sure none of the bare wire used as the panel ground is in danger of shorting against other connections. One more pass of inspecting the board for component polarity and quality of solder joints is a good idea too.

TESTING

Set Scale A and B trimmers (R27,R58) to the midpoint of their rotation, corresponding to a 1V/oct scale. Also set Sym A and B (R87,R5) trimmers midscale. Make sure the power supply is turned off and mate the power connectors.

- 1) Set the 9720 knobs and switch as shown and turn on power. First observe the POWER light on the power supply and if it doesn't come on stop and find out why. *It may be just a dead outlet or some more serious problem such as a solder bridge on the 9720 board. If the power supply light comes on when the 9720 is disconnected, it's a sure sign of a problem on the 9720 board. The most likely area for this problem is in the area around the power connector, R1, R2, C1, C2 and the voltage regulators IC1 and IC2.*

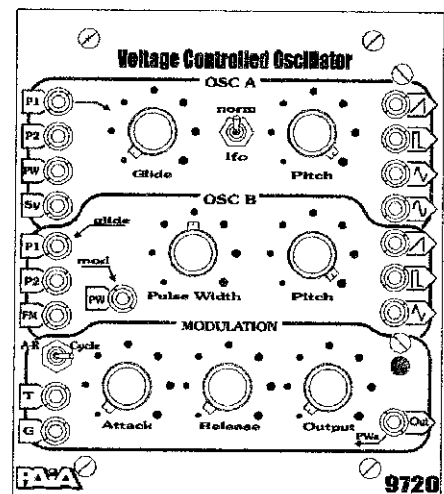

2) Check the modulator light on the 9720 front panel. It should be lit, but not very brightly. If the LED is dark or seems fairly bright, quickly feel around on the circuit board to see if any parts are hot or very warm. If you find any, disconnect the power and carefully examine the circuitry around the hot part looking for solder bridges, backward capacitors or other polarized parts. If nothing seemed warm but the LED is dark and the panel switch is set to "Cycle" it may be a problem in the Modulator circuit. Carefully check the modulator parts (Q4-Q6, IC8, panel controls R200-R202 and associated components). Check the LED, it may be in backwards or may be bad. It's human to suspect bad ICs but most problems relate to the mechanics of assembly - the wrong part in the wrong place or facing the wrong way or not soldered well.

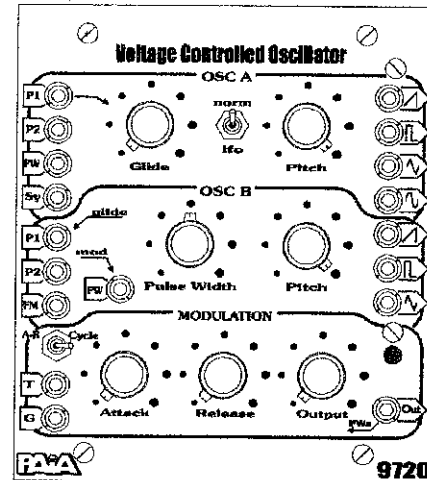

3) Rotate the Modulation Attack control to the midpoint of its rotation. The LED should now increase in intensity over a 2 second period then suddenly go dark and repeat the cycle. Turn the Modulation Release control to about the midpoint of its rotation and observe that the LED slowly brightens and slowly dims with about a 5 second period. If that goes well, crank both Attack and Release controls full ClockWise and observe that the period is about 15 seconds. If there are problems here, check the modulator components outlined in step 2, paying particular attention to correct values. If cycle times are significantly different (half or twice more, for instance) it may indicate an incorrect component value or power supply lines that are out of spec - check for hot parts among the power supply components mentioned in step 1, and if a Volt Meter is available check the regulated supply lines - IC3 pins 4 (+12V) and 11 (-12V) are handy places.

4) Listen to the Ramp outputs () of OscA and OscB in turn. Each should be about 120 Hz and of equal amplitude. If you have a Volt meter handy, use it to measure the voltages on these outputs. Both outputs should be about the same and when the meter is set to read DC you should measure 200mVolt (0.2V) or less. With the meter set to AC you should read 1.25V. If no meter is available do not be concerned with these measurements unless there are problems in future steps.

While listening to OscA's ramp output, rotate the Pitch control fully CounterClockWise and observe that the pitch falls by about 3 octaves to 15 Hz. or so. Do the same with OscB. Be sure to return both Pitch controls to max (fully ClockWise) for future tests.

Problems here can come from a lot of different sources. If there is no audible output from OscA check IC7:A & :B and IC6:D, Q10 and associated components. Corresponding parts in OscB are IC3:A & :B IC6:A and Q7. If there is output but it's very high or low frequency or doesn't change as described above it may be CV summing/current sources. For OscA these comprise IC4, Q2, Q3 and associated components. If OscB is not functioning properly IC5, Q8, Q9 and components associated with them should be examined. These ramp outputs must be working before any of the others will work properly.

5) Listen to the Pulse output () of each oscillator. They should be the same pitch as the Ramp outputs and approximately as loud. The two Pulse outputs will probably be set to different pulse widths so timbres may not be identical. *OscA Pulse problems point to IC6:C and the resistors associated with it. The OscB Pulse output is shaped by IC6:B and it's associated parts.*

While listening to the OscB Pulse output rotate the Pulse Width control from fully CCW to fully CW and observe the characteristic "flanging" timbre of varying duty factors. *Check the wiring of R206 if there is no change or if the output goes quiet at either end of the control rotation.*

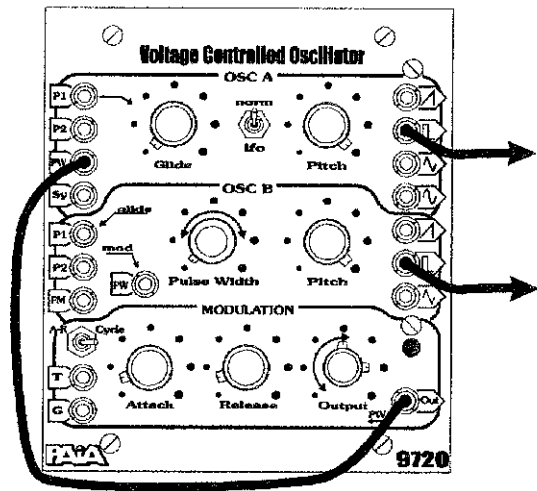

Set the Pulse Width control to the CCW limit and adjust the Modulator's Attack and Decay control so the output LED shows a cycle time of a second or so. While listening to OscB pulse output increase Modulator output level and observe PWM effect. Observe that rotation of the Modulator Output control CW beyond the 3 o'clock cause the output to be silent for a part of each Modulator cycle.

Use a Patch cord to connect the Modulator out to OscA PW input and listen to observe PWM effect. Notice that the output is silent for a part of each cycle when the Output control is CW beyond the 12 o'clock position. *Problems with these tests of the Pulse outputs will likely trace to resistor value or soldering problems in the components associated with the Pulse Width shapers.*

Switch OscA to LFO and observe 50 Hz at Pitch max decreasing to less than a cycle/minute at min. *Problems here focus on wiring of S2.*

6) Listen to Triangle outputs (). Adjust sym A (R87) and sym B (R5) for most mellow tone which should happen about mid range. *If there is no "most mellow" point between the extremes of the trimmer's rotations check A- IC8:B B-IC3:C*

7) Listen to the Sine output of OscA () for a mellow sine sound. *If not check IC8:A and polarity of diodes D11-D13,D17,D18.*

We're now ready to calibrate the oscillators so that a 1V change in Control Voltage produces a 1 octave change in pitch. The calibration procedure is written as if no equipment such as Oscilloscope, Frequency Counter or digital voltmeter is available. If you have this kind of equipment it may be used and there are some tips and pointers at <http://paia.com/9720test.htm>. But the results produced using this equipment will be no more accurate the equipment-free procedure that follows.

During calibration one oscillator will be used as a fixed reference while the other oscillator is adjusted. Use the Triangle outputs (∇) of OscA and OscB and arrange for both to be heard at the same time at approximately equal amplitudes. If a PAiA 9710 Triple VCA is available it's L and R inputs can be used to mix the two to a single output. Lacking a mixer, the L and R inputs of a Stereo Amp switched to Mono can be used as shown in the illustration.

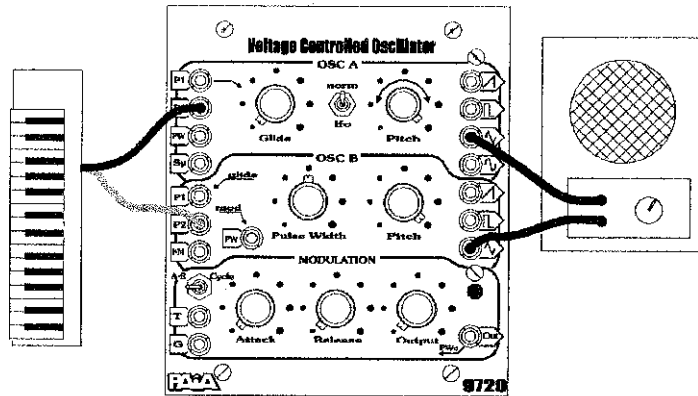

8) Begin calibration with OscA. Apply a 1V/octave controller, such as a midi2cv8, to the P2 input of OscA and cause the controller to output 4V (typically by pressing the 5th C on a keyboard). Adjust OscA Pitch control until the pitch of OscA is 2 octaves above that of OscB. Cause the controller to output 0V (typically by pressing lowest C) and adjust Scale A trimmer (R27) until the pitch of OscA is 2 octaves below the reference.

Once again cause the controller to output 4V and again adjust OscA Pitch for 2 octaves above reference, then 0V again while adjusting Scale A for 2 octaves below the reference. Iterate the above procedure until satisfied with both the high and low end.

OscB is calibrated in the same manner. Disconnect the controller from OscA P2 and reconnect to OscB P2 as shown in grey in the illustration. With 4V. output from the controller adjust OscB pitch for 2 octaves above OscA then with 0V output adjust Scale B trimmer (R52) for a pitch 2 octaves below OscA. Iterate this procedure until satisfied with the tuning at high and low end.

Disconnect the controller from OscB P2 input and reconnect to OscA P1 so that both Oscillators track the controller and observe tracking as pitch CV varies. Some further tweaking of the calibration of one or both VCOs may be necessary for best tracking. *It's unlikely that the VCOs will pass previous tests and then not calibrate properly. If it happens, most likely cause will be a resistor with an incorrect value. Double check values of resistors associated with the CV summing/current sources as outlined in step 4.*

9) Test OscA Sync input by reconnecting the controller to OscA P2 input and using a patch cord to connect OscB Pulse output to OscA Sync as shown on the facing page. Set both Pitch and Pulse Width controls of OscB fully CW. While listening to the Sine output of OscA only, press the 3rd C on the controller for a 2V. CV output. As you rotate the OscA Pitch control you should hear the output switch between a number of timbres that are considerably more complex than a simple sine wave. As pitch is varied by playing up and down scale notes on the controller the timbre should stay the same. *If there are problems here check the wiring of J4 and C17 and R9 on the circuit board.*

(10) Switch the Modulator from Cycle to A-R and connect a trigger source (such as the appropriate trigger output of a midi2cv8 to input G (Gate). Gate input signals should be "true positive" and transition from ground to a positive voltage between 4 and 15V to trigger the Modulator. Activate the trigger and by watching the Modulator LED verify that the modulation output rises when the trigger signal goes on and stays high as long as the trigger is present. When the gate signal is removed the modulator output should return to zero volts. Apply the same trigger signal to the T (Trigger) input and observe that the output rises in response to the trigger but releases as soon as it reaches the peak, even if the trigger is still present. *If there are problems with these tests check the wiring of jacks J8 and J9. On the circuit board check Q5, D6 and the associated resistors.*

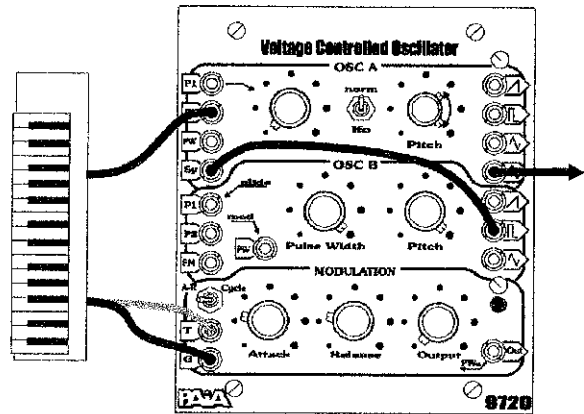

If you have unresolved problems review the Design Analysis section while looking at the schematic. It may seem like greek the first time you read through it but on a second reading more things will make sense and on a third even more. Be sensitive to how different sections of ICs are used. For example, notice that both the OscA Ramp and OscB Pulse outputs use sections of IC6. If OscA is not working at all and OscB's Pulse output is also not working (but other OscB outputs are) It may be the part that is common to the two, IC6, so closely examine it's orientations, how it is soldered, feel it for excess heat and so on.

Successful completion of these tests is a good indication that the module is working properly.

- () Gather the wires from the circuit board to the front panel controls together and cinch the bundle with the three Nylon Wire Ties supplied as shown in the photo. Cinch the ties tight and clip off the excess.

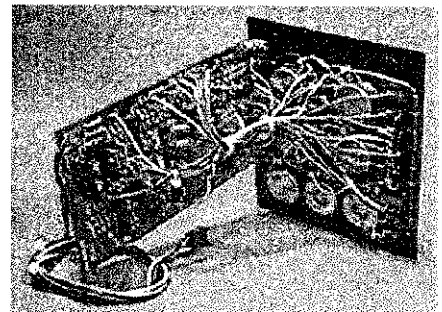



THE PANEL CONTROLS

You got to know the panel controls pretty well during testing. Here's a different perspective on what they do.

VCO CONTROLS

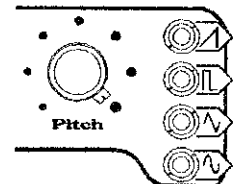
Pitch. Each Oscillator has its own independent Pitch knob with a range of slightly more than 3 octaves. With no external CV inputs each oscillator produces a pitch of approximately C_3 (C below middle C) at "max" fully ClockWise rotation and C_6 at "min" fully CounterClockWise rotation.



 **OscA Pitch CV Input 1.** This 1V/oct scaled input is routed through the Glide processor as indicated by the arrow pointing into the Glide control.

 **OscA Pitch CV Input 2.** This input is scaled 1V/oct. The final pitch of either oscillator is set by the setting of the Pitch control and the sum of the voltages at the P1 and P2 inputs.

 **OscA Pulse Width Input.** When there is no external input to this jack OscA PW defaults to a roughly 20% Duty Factor. Plugging into this input provides control of PW over a range of -5V (lowest DF) to +5V (highest DF) with 0V for 50% DF square wave.



OscA norm/lfo switch. Switching to LFO rescales OscA from 1V./oct. to about 250 mV/oct so that the Pitch knob produces 50 Hz. at max and 1/60 Hz (1 cycle/minute) at min. CV inputs are still active but at this same increase in sensitivity.

 **OscA Sync input.** Provides a "soft-sync" input for OscA. Soft sync timbres are characterized by harmonic partials that may increase in amplitude as their order increases, or may be absent in other than the odd/even order patterns that define ramp, triangle and pulse waveforms.

 **OscB Pitch CV Input 1.** The arrow indicates that this input is normalized to the output of the glide processor and consequently OscA P1. Inserting a plug into this input overrides the normalization for independent control of the oscillator. The **OscB P2** input serves the same function as the corresponding input on OscA.

 **OscB Frequency Modulation Input.** This input provides a linear 1kHz/V input. Only positive voltages produce a change.



 **OscB Pulse Width.** The arrow pointing into this indicates that it is normalized to the output of the Modulator. Pulse Width (Duty Factor) is a function of both the Pulse Width knob and the voltage at this input. Input sensitivity is scaled so that 1V change at the input produces a 10% difference in Duty Factor.

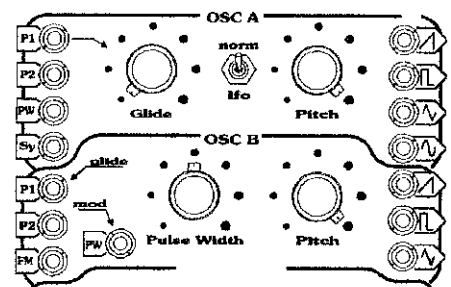



VCO Outputs

All VCO outputs are DC coupled 5V peak to peak centered about ground. For example, the Pulse outputs are -2.5V when low and +2.5V when high at any frequency or Duty Factor.

 **Ramp Output-**
Odd and even harmonics

 **Triangle Output-**
Odd harmonics only

 **Pulse Output**
Harmonics depend on DF

 **Sine Output**
About 5% harmonic distortion.

OscA Glide. Sets how fast oscillators respond to Pitch CV changes. At "min" fully CCW the change from one pitch to the next is perceptually instantaneous. At "max" full CW portamento from one pitch to the next takes several seconds.

OscB PW. This control sets initial Duty Factor of the OscB Pulse output. At "min" the Pulse output is a square wave (~50% DF). At "max" the output is a narrow negative pulse (>95% DF)

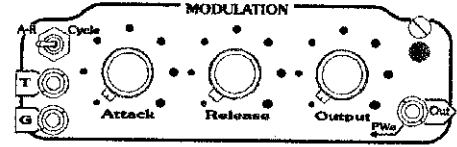

MODULATOR CONTROLS

T **Trigger Input** - A transition from ground to 4V or greater triggers the Modulator. Attack cycle followed immediately by Release with no Sustain interval.

G **Gate Input** - A voltage greater than 4V gates the modulator. Attack cycle is followed by Sustain for as long as the Gate is present. Release when Gate returns to ground.

A-R **Cycle** **A-R** - The normal Attack (Sustain) Release function of the modulator.
Cycle - In this mode the Modulator self-triggers for a Low Frequency Oscillator function. Repetition period is the sum of the Attack and Release times. Cycle mode responds to a true Gate input by interrupting the cycle with the output high. Periodic Trigger pulses hard sync the LFO.

Output - Amplitude of the Control Voltage from this output is set by the Output control. The arrow indicates that the Modulator Output is normalized to the Pulse Width Modulation input of OscB. Inserting a plug does not interrupt the normal.

Attack - Sets the time required for the output to rise to its peak level. Time range is 500 μ S (0.5 mS) at the CCW extreme to 6S when the control is fully CW.

Release - Sets the time required for the output to return to "zero". Time range to return to less than 1V is 2mS at the CCW extreme to 10S when the control is fully CW.

Output - Sets the output Level. Range of control is 0V at the CCW extreme and about 10V peak when the control is fully CW.

THE BLOCK DIAGRAM Fig 6 in the illustrations supplement shows the organization and normalization of the panel controls, inputs and outputs.

Response to T



Response to G



Trigger/Gate



A-R functions

Attack = Release



Attack > Release

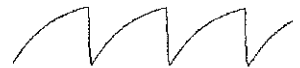

Attack < Release

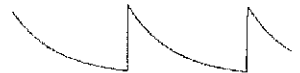

LFO functions

Response to T

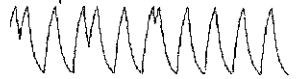

Response to G



Trigger/Gate



LFO Sync / Gate

Design Analysis

Oscillators - The two VCOs in the 9720 have essentially identical core elements. Taking OscA as typical, IC7:A, IC6:D and Q10 are the active elements in a relaxation oscillator topology. C11 is the timing capacitor which is charged by a current source to be described shortly. As C11 charges a linear voltage ramp is produced across the capacitor. JFET input opamp IC7:A is configured as a voltage follower that buffers the voltage on the capacitor from the impedances of other processing elements.

One of these processing elements is a Schmitt trigger comprising comparator IC6:D and associated components. When the Voltage ramp from buffer, coupled by R19, passes a threshold of about -4V the Schmitt trigger changes state and it's output is pulled from the negative supply rail up to ground by R70. The resulting current flow through R69 turns on Q10 which quickly discharges C11 through R88. When the capacitor has discharged to the point that the voltage at the output of the buffer is less than -8.5V, IC6:D's output is again pulled to the negative supply voltage and Q10 turns off. With Q10 no longer conducting C11 begins charging again and the cycle repeats. Diodes D9 and D10 limit base-emitter junction saturation and capacitor C10 helps in discharging the parasitic capacitor at the b-e junction, both in the interest of speeding up the switching time Q10. C11 discharges in less than a μ Sec.

Opamp stage IC7:B and associated resistors comprise a buffer that both scales and transposes the relaxation oscillator's ramp to a 5V p-p (-2.5V to +2.5V) output available at J11.

The ramp at the output of IC7:B also drives the Triangle wave shaper that has opamp IC8:B as it's active element. As the ramp increases toward ground from its minimum of -6.5V, diodes D15 and D16 are both reverse biased and the opamp acts as a unity gain inverter with it's output decreasing from +2.5V. The output continues decreasing until the voltage of the ramp reaches the voltage at the opamp "+" input (Set by trimmer R87) then both diodes begin to conduct and the opamp stops being an inverter and turns into a voltage follower. It's output stops decreasing and begins to increase. The output continues to increase until the ramp reaches it's peak (+3V) and resets back to minimum, then the diodes once again reverse bias and the opamp switches back to an inverter with it's output high. Setting Sym trimmer R87 sets the inflection point and is adjusted so that the triangle shaper output voltage is the same at the end of the ramp as it was at the beginning. Capacitors C18 and C21 add a high frequency roll-off to the triangle shaper that minimizes the "glitch" in the triangle waveform that is a natural consequence of the ramp resetting from high back to low.

The triangle output of IC8:B is shaped to approximate a sine wave by opamp IC8:A and diodes D11-D14, D17 and D18. As the amplitude of the triangle rises and falls the diodes forward and reverse bias to produce lower gains at higher input voltages causing the triangle peaks to bend over into a sine wave.

The ramp from IC7:B also drives the Pulse Width modulator consisting of comparator IC6:C and the parts around it. After being scaled and transposed by R71 and R72 the ramp is compared to a CV from J3 that is scaled and transposed by R76 and R77. When the repre-

resentation of the ramp voltage at the comparator's "+" input is greater than the control voltage at the "-" input the comparator changes state and it's output is pulled from the negative supply rail toward the positive rail by R82 and R74. These two resistors, along with R75 scale and transpose the comparator output to a 5V p-p (-2.5V to +2.5V) pulse at J12. Higher Control Voltages cause the switch point to happen later on the ramp and consequently determine the Duty Factor (the percentage of the total period of the waveform that the pulse high).

While fundamentally identical, there are minor differences in the A and B oscillators and wave shapers to accommodate different features. OscB's Pulse shaper (IC5:B) has the added panel control (R206) and the voltage at it's wiper is summed with the PW CV input at J10 to determine Duty Factor. Also in OscB, the opamp IC3:A and Q1 together form a linear voltage controlled current source for timing capacitor (C16). The linear frequency control input at J7 if useful for producing complex FM Synthesis timbres.

In OscA C17 and R9 couple external sync signal to the "+" input of comparator IC6:D. Sync inputs periodically boost the ramp input to this comparator slightly and if it comes at the right time to exceed the reference voltage the comparator changes state and discharges the timing capacitor earlier than would be normal. Depending on sync signal amplitude and frequency the premature ending of the ramp may not happen on every cycle producing complex waveforms.

Voltage Summing/Exponential Current Source

Like most exponential converters the 9720 circuits exploit the exponential relationship between the voltage applied to a semiconductor junction and the current that flows through the junction because of that voltage. Taking OscA as typical, the voltage across the b-e junction of Q3 produces a collector current that is exponentially related to voltage increases. When properly calibrated, collector current will double for each 18mV increase in b-e voltage.

The V/I characteristics of a transistor are very temperature sensitive, with T appearing as an exponent twice in the equation describing the relationship. As is common in these converters, Q2 is hand selected to be matched in characteristics with Q3 and is added to cancel out the largest effect of temperature.

In most other expo converters the remaining temperature dependency is reduced by using a Temperature Compensating (tempco) resistor to vary the gain of a simple opamp circuit that sums several control voltages and scales the result to the 18mV/oct needed at Q2's b-e junction. The 9720 expos take a slightly different approach here and instead use the two stages of an LM13700 type Operational Transconductance Amplifier (IC4) to perform this summing and scaling function. In this scheme a diode ordinarily used to linearize the OTA transfer function is configured instead to reduce the gain of the summation as temperature increases. This topology has several advantages over the traditional tempco approach: Cost is less because the somewhat exotic and consequently expensive tempco resistor is eliminated. From a purely technical standpoint the diode is a better approach because it exactly compensates temperature variations over a range of temperatures while a tempco resistor

provides exact compensation at only a single temperature because while resistance varies as T, the actual term being compensated is 1/T.

The glide processor consists of IC7:C & :D. Changes in CV at J1 are buffered by IC7:C wired as a voltage follower and used to charge C12 through R22 and the panel control R205. The voltage on the capacitor is read out by a second voltage follower (IC7:D) and the follower output voltage summed into total control voltage for OscA through R14 and OscB through the normalization of J5 and R40.

Modulator - To follow the operation of the Modulator as ASR, imagine the Cycle switch S1 is open. A high level at the Gate Input (J9) turns on Q5 so that the voltage at its collector falls to near ground. A couple of things happen in response to this - Q4 is turned on by the current through R34 and its collector current begins to charge the timing capacitor C22 through the Attack control R91. Also when Q5's collector voltage falls it turns off Q6 and Q6's collector voltage goes high so that the current flow through R38 will hold Q5 on even if the Gate signal goes away. The bistable action of Q6 and Q5 holds the modulator in the attack state until the voltage on the timing cap reaches the peak voltage. IC8:D is a buffer that reads the voltage on the timing cap C22. The output of the buffer drives LED1 through current limiting resistor R104 and also connects to the Output Level control R202.

IC8:C is configured as a comparator with hysteresis set by R101 which couples to the buffered timing capacitor voltage and the positive feedback resistor network R100/R106. These values are chosen so that when the timing voltage reaches 10V the voltage at the "+" input of the comparator (pin 10) exceeds the reference voltage at the "-" input (pin 9) set by R96 and R103 and the comparator changes state with its output going from -12V to about +10V. This voltage, coupled through R102 turns on Q6 which causes its collector voltage to go to ground. At this point, if the Gate In is still true nothing further happens and the output sustains at the peak output level. If the Gate is off, or when it subsequently goes off, Q5 turns off and its collector voltage goes high turning off Q4. With Q4 off the Decay part of the cycle is active and the voltage on the timing capacitor decreasing as charge drains off through R33 and the Decay control R201. Steering Diodes D1 and D2 force C22 to charge through R91 and discharge through R201. R32 and C13 form a network that resets the comparator when an active Gate causes Q4's collector to switch high.

When the timing voltage falls to about 1V the comparator's "+" input becomes less than the "-" reference input and its output falls from +10V to -12V, ready for the next Gate. When the cycle switch (S1) is closed, this negative transition is coupled by R67 and C22 to the base of Q6 and unconditionally turns this transistor off. Q6's now high collector voltage turns Q5, and consequently Q4, on - starting the Attack cycle again.



9720 Parts List

qty	description	designation	3	39k	orange-white-orange	*R208,R28,R55
Semiconductors						
18	1N4148 or 1N914 Si diodes	D1-D18	1	470k	yellow-violet-yellow	R30
1	red LED	LED1	4	47k	yellow-violet-orange	R39,R69,R92,R105
1	7812 +12V Regulator	IC2	1	56	green-blue-black	R2
1	7912 -12V Regulator	IC1	4	5600	green-blue-red	R64,R82,R36,R37
2	TL084 Quad FET OpAmps	IC3,IC7	6	56k	green-blue-orange	R20,R23,R44,R48, R71,R93
2	LM13700 Dual OTA	IC4,IC5	2	750	violet-green-brown	*R207,R29
1	LM324 Quad OpAmps	IC8	2	82k	grey-red-orange	R98,R101
1	LM339 Quad Comparator	IC6	4	91k	white-brown-orange	R8,R59,R80,R103
4	2N3904 Si NPN Transistor	Q5,Q6,Q7,Q10	1/4W. 1% metal film resistors			
2	2N3906 Si PNP Transistor	Q1,Q4	5	100k	brwn-blk-blk-orng	*R209,R14,R16, R40,R42
2	2N3906 Matched Pair	Q2/Q3,Q8/Q9	Miscellaneous			
Ceramic Disk Capacitors						
3	0.001uF	*C24,C13,C17	2	mini Toggle Switches		*S1,*S2
6	0.01uF	C3,C5,C9,C15, C20,C23	1	9720 circuit board		
7	15pF	C7,C8,C10,C14, C18,C19,C21	1	Assembly Manual		
Polystyrene Capacitors						
2	4700pF	C11,C16	7	set screw knobs		
Electrolytic Capacitors						
2	1uF 15V.	C12,C22	4	5ft lengths #26 stranded wire		
2	470uF / 25V.	C1,C2	1	18 inch length #24 bare wire		
2	4.7uF / 15V	C4,C6	1	4" length small diameter tubing		
Potentiometers						
2	5meg Panel Mount	*R200,*R201	1	3" length large diameter tubing		
1	1 meg Panel Mount	*R205	5	Nylon wire Ties		
3	100k Panel Mount	*R203,*R204,*R206				
1	10k Panel Mount	*R202				
2	10k pc Trimmer	R5,R87				
2	1k pc Trimmer	R27,R58				
1/4W 5% resistors						
3	1.5m brown-green-green	R21,R43,R97				
11	100k brown-black-yellow	R3,R6,R10,R12, R35,R38,R89,R90, R94,R95,R96				
5	10k brown-black-orange	R34,R47,R56,R68, R78				
2	10meg brown-black-blue	R63,R73				
5	120k brown-red-yellow	R7,R18,R45,R77,R79				
3	12k brown-red-orange	R19,R54,R61				
2	1500 brown-green-red	R66,R75				
1	150k brown-green-yellow	R91				
1	15k brown-green-orange	R76				
1	180k brown-grey-yellow	R60				
4	18k brown-grey-orange	R4,R11,R81,R86				
2	1k brown-black-red	R31,R57				
1	22 red-red-black	R1				
4	220 red-red-brown	R24,R46,R50,R88				
8	2200 red-red-red	R13,R15,R22,R32, R65,R74,R83,R84				
3	220k red-red-yellow	R100,R102,R106				
2	2400 red-yellow-red	R25,R52				
4	27k red-violet-orange	R51,R62,R67,R72				
7	3300 orange-orange-red	R26,R49,R53,R70, R104,R33,R99				
2	33k orange-orng-orng	R9,R85				
2	390k orange-white-yellow	R17,R41				

9720FRM FracRak Accessory Kit

18	1/8" CC Jack
1	9720 FracRak Panel
2	#4 "L" Brackets
2	4-40 Machine Nuts
4	#4 X 1/4" Machine Screws
4	Self-tap Screws
9790 Power Connector Kit parts:	
1	4 pin .1 Friction Lock header
1	4 pin .1 terminal housings
4	.1 crimp terminals
4	16" lengths #22 stranded wire
3	Nylon Wire Ties

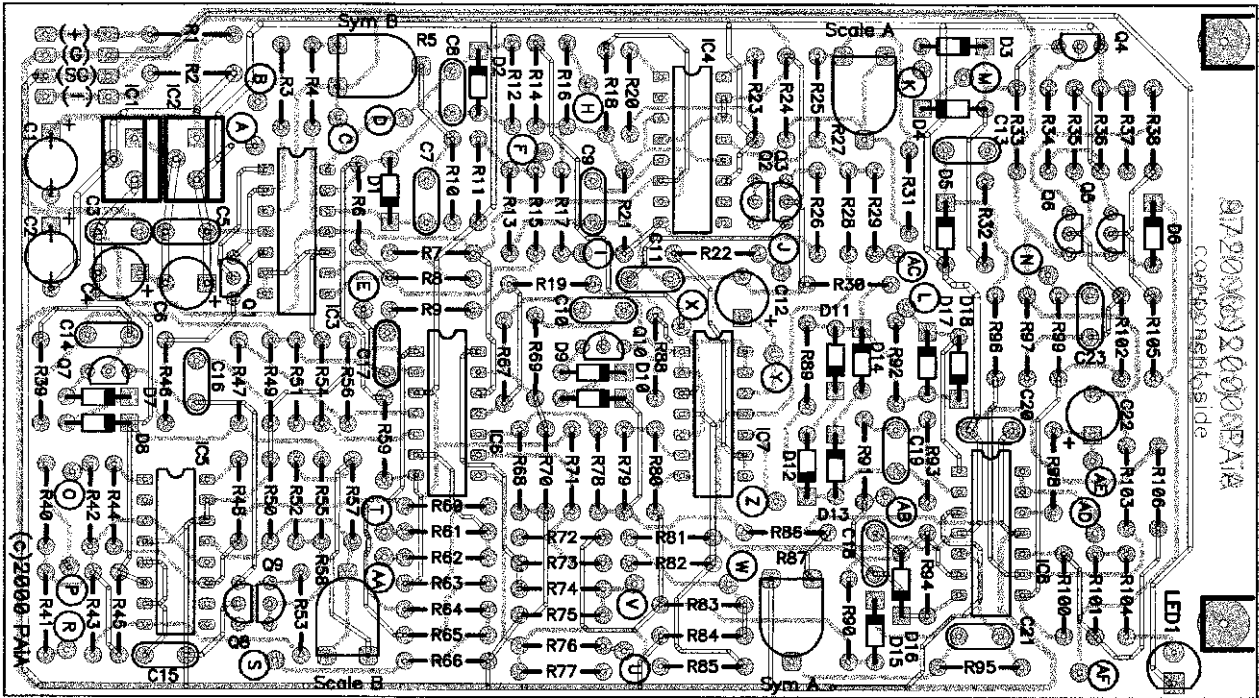

Fig 1. Circuit board parts placement and trace routings. Copper traces on the top of the board are shown in bold outline, useful if you need to trace the circuit though areas covered by ICs or other parts. Traces on the bottom of the board and their connections to components are shown in grey.

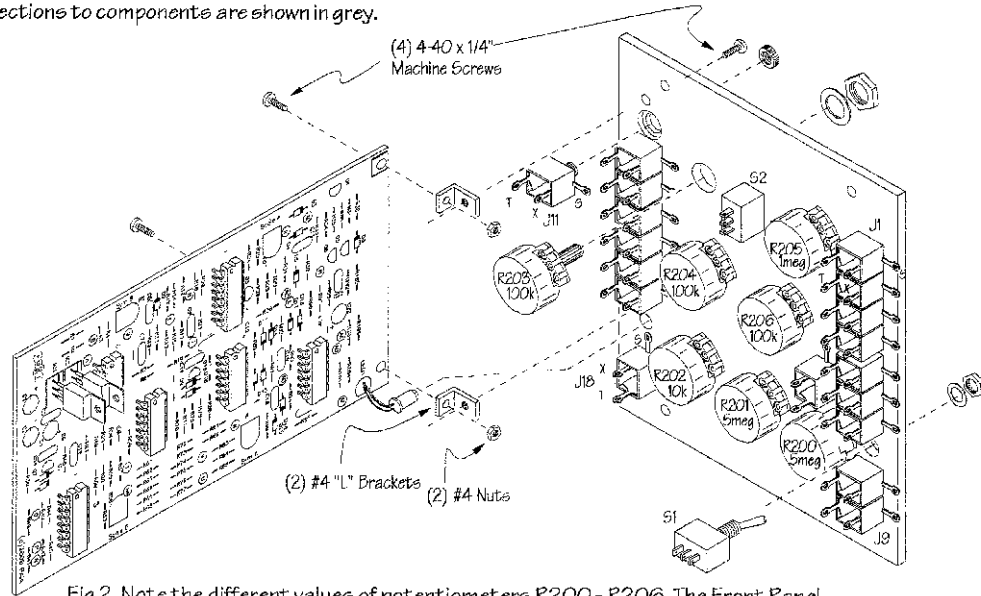

Fig 2. Note the different values of potentiometers R200 - R206. The Front Panel attaches to the circuit board with "L" brackets and #4 hardware. Note that the threaded bracket holes are used to attach the brackets to the panel.

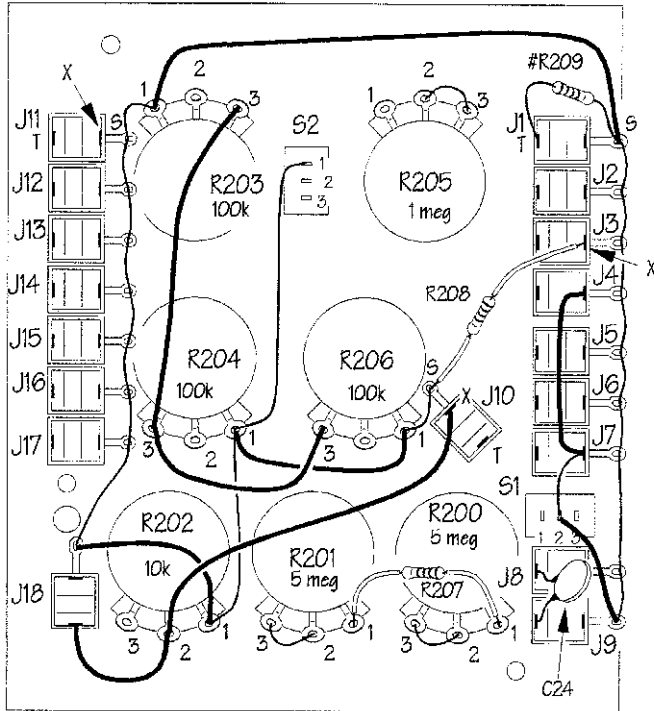
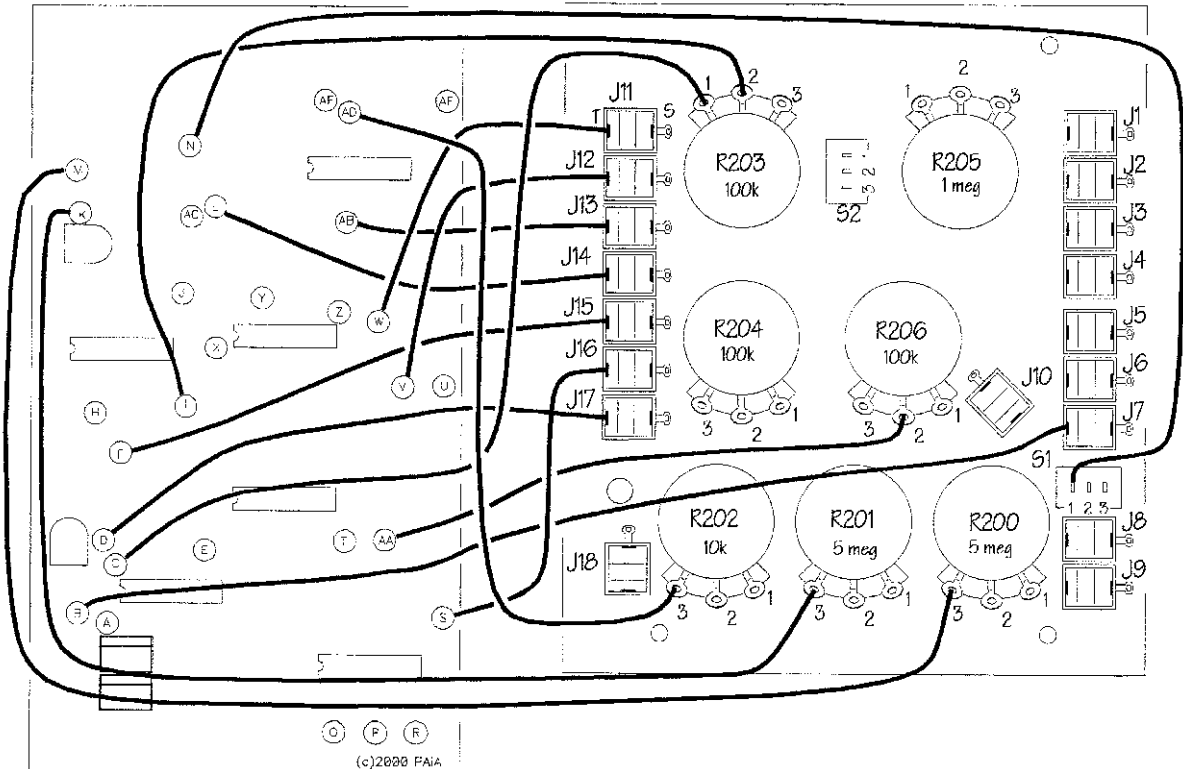

Fig 3 (left). Wiring on the panel uses bare wire and #26 stranded, insulated wire. Connecting to the "S" (Sleeve) lugs of J11-J18 will be easier if done before the potentiometers are mounted. Note the insulation over the leads of R207 and R208. #R209 is 1% tolerance.

Fig 4 (below). #26 insulated, stranded wire is used for the connections between the front panel and circuit board. Previous wiring has been eliminated for clarity.



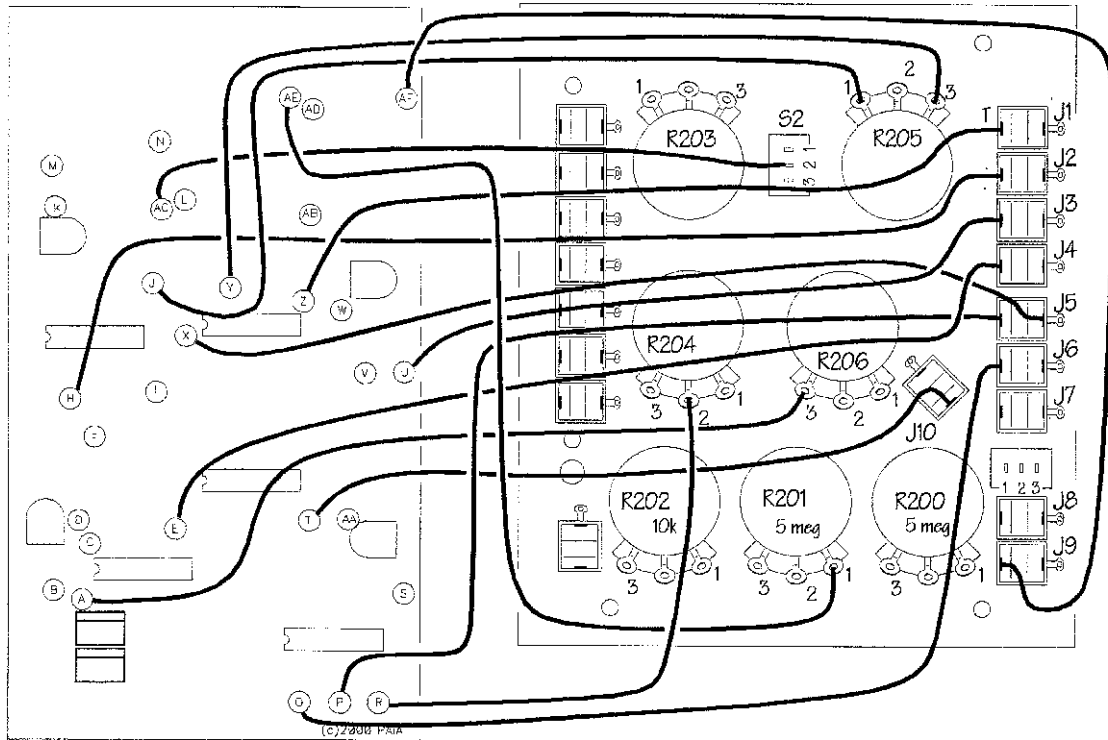

Fig 5. Wiring between panel and circuit board continues with #26 stranded, insulated wire as above. Previous connections omitted for clarity.

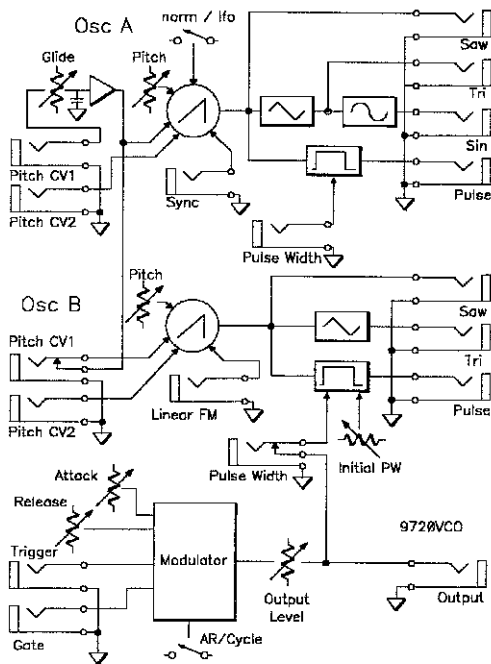

Fig 6. 9720 Dual VCO w/Modulator Block Diagram.

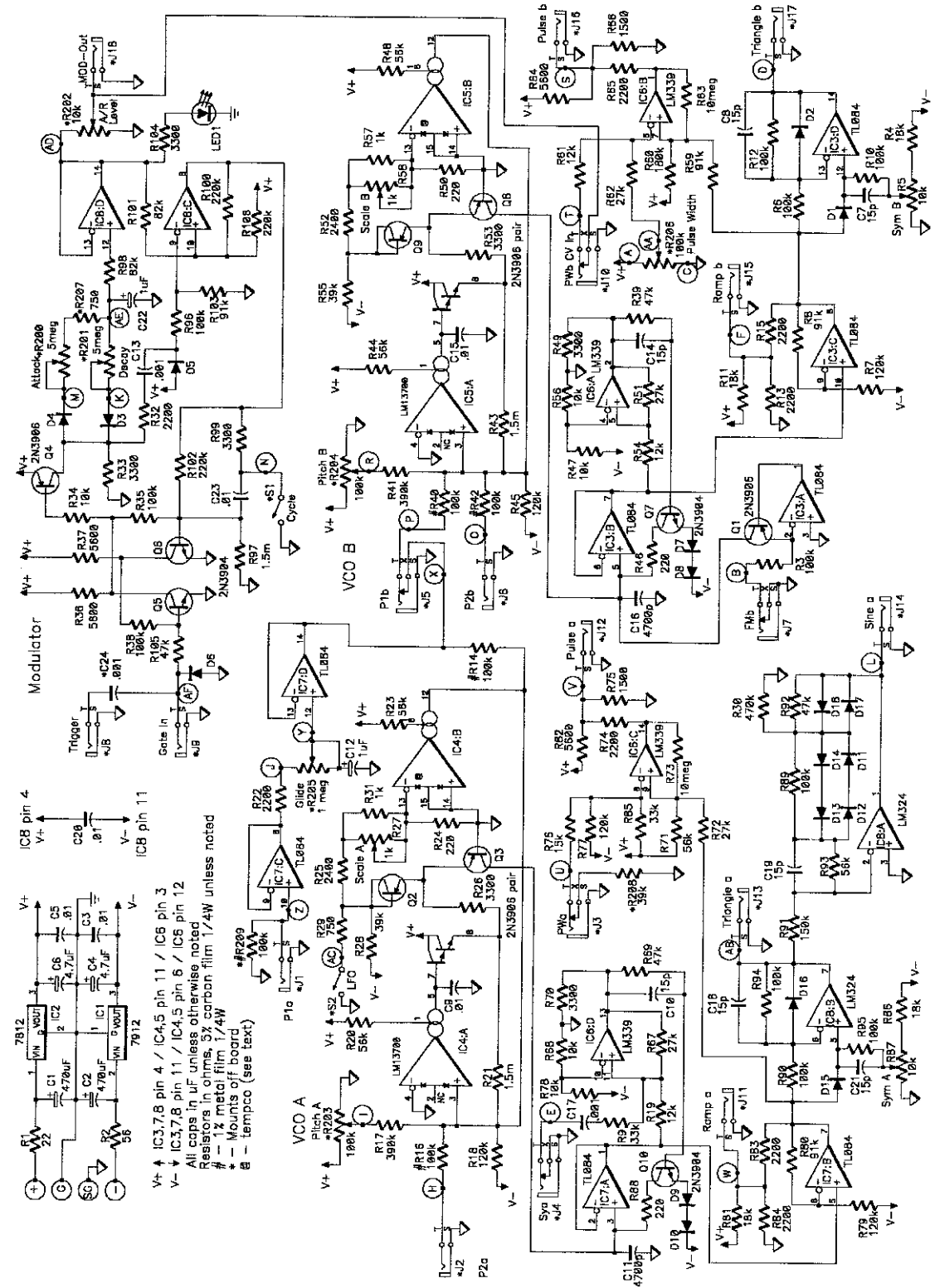

Fig 7. Dual VCO w/ Modulator. "@" marked diodes that are part of the LM13706s used for pitch Control Voltage summation provide temperature compensation.