

ENVELOPE GENERATOR

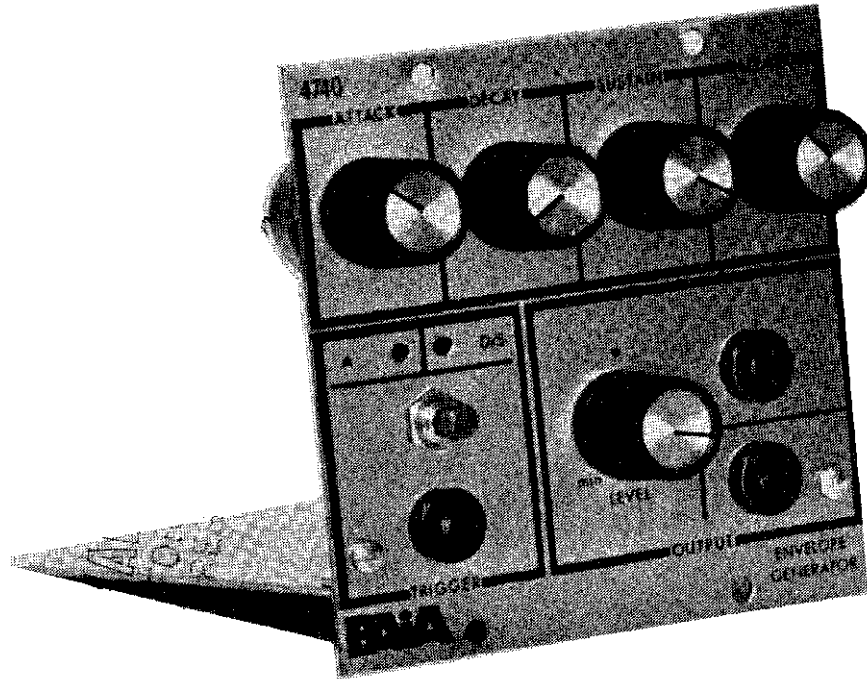

The 4740 ADSR Envelope Generator provides the synthesist with a triggerable source of programmable time varying voltage that is useful in controlling filters, oscillators, amplifiers or other voltage controllable elements. Front panel controls allow independent, non-interactive adjustment of the output voltage's rise time (attack), initial decay, sustain level and final release time. Electrical and manual triggers are provided for and front panel light emitting diodes indicate the status of the module.

SPECIFICATIONS

Power Requirements:	+18v. @ 17 ma.
Trigger Input Impedance:	66,000 ohms nominal
Output Impedance:	less than 1K ohms
Peak Output Voltage:	5 volts nominal
Attack, Decay, Release Time Range:	2 ms. to 1.5 sec. nom.
Triggering Voltage:	3.5 volts nom.
Sustain Level Range:	.5 to 5 volts
Front Panel Indicators:	attack and decay/sustain Light Emitting Diodes

SOLDERING

Use care when mounting all components. Use only rosin core solder (acid core solder is never used in electronics work). A proper solder joint has just enough solder to cover the round soldering pad and about 1/16 inch of the lead passing through it. There are two improper connections to beware of: Using too little solder will sometimes result in a connection which appears to be soldered but actually there is a layer of flux insulating the component lead from the solder bead. This situation can be cured by re-heating the joint and applying more solder. If too much solder is used on a joint there is the danger that a conducting bridge of excess solder will flow between adjacent circuit board conductors forming a short circuit. Unintentional solder bridges can be cleaned off by holding the board up-side down and flowing the excess solder off onto a clean, hot soldering iron.

Select a soldering iron with a small tip and a power rating not more than 35 watts. Soldering guns are completely unacceptable for assembling transistorized equipment because the large magnetic field they generate can damage solid state components.

CIRCUIT BOARD ASSEMBLY

There are two circuit boards supplied with the 4740 Envelope Generator, the larger "A" board that mounts most of the electronic components and the smaller "B" board that will be used in later steps to mount the Light Emitting Diode status indicators.

- () Prepare for assembly by thoroughly cleaning the conductor side of the "A" circuit board with a scouring cleanser. Rinse the board with clear water and dry completely.

Solder each of the fixed resistors in place following the parts placement designators printed on the circuit board and the assembly drawing figure 1. Note that the fixed resistors are non-polarized and may be mounted with either of their two leads in either of the holes provided. Cinch the resistors in place prior to soldering by putting their leads through the holes and pushing them firmly against the board, on the conductor side of the board bend the leads outward to about a 45° angle. Clip off each lead flush with the solder joint as the joint is made.

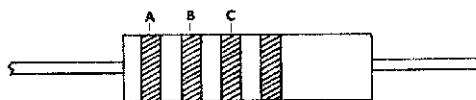

silver or gold disregard this band.

DESIGNATION	VALUE	COLOR CODE A-B-C
() R1	100 ohm	brown-black-brown
() R2	33K	orange-orange-orange
() R3	33K	orange-orange-orange
() R4	33K	orange-orange-orange
() R5	330K	orange-orange-yellow
() R6	220K	red-red-yellow
() R7	680	blue-grey-brown
() R8	47K	yellow-violet-orange
() R9	47K	yellow-violet-orange
() R10	100K	brown-black-yellow
() R11	100K	brown-black-yellow
() R12	68K	blue-grey-orange
() R13	680	blue-grey-brown
() R14	1K	brown-black-red
() R15	330K	orange-orange-yellow
() R16	3300	orange-orange-red
() R17	470K	yellow-violet-yellow
() R18	470K	yellow-violet-yellow
() R19	680 ohm	blue-grey-brown
() R20	3.9 meg	orange-white-green
() R21	3.9 meg	orange-white-green
() R28	100K	brown-black-yellow
() R29	330K	orange-orange-yellow
() R31	680K	blue-grey-yellow
() R32	220K	red-red-yellow
() R33	2200 ohm	red-red-red
() R34	15K	brown-green-orange
() R35	1K	brown-black-red
() R36	2200	red-red-red

Install the ceramic disk capacitors. Without exception the value will be marked on the body of the part.

DESIGNATION	VALUE
() C201 mfd. disk
() C401 mfd. disk

Up to this point all components have been non-polarized and either lead could be placed in either of the holes provided without affecting the operation of the unit. Electrolytic capacitors are polarized and must be mounted so that the "+" lead of the capacitor goes through the "+" hole in the circuit board. In the event that the "-" lead of the capacitor is marked rather than the "+" lead it is to go through the unmarked hole in the circuit board.

Note that the operating voltage (v.) specified for a capacitor is the minimum acceptable rating. Capacitors supplied with specific kits may have a higher voltage rating than that specified and may be used despite this difference. For instance, a 100 mfd. 25v. capacitor may be used in place of a 100 mfd. 16v. capacitor without affecting the operation of the circuit.

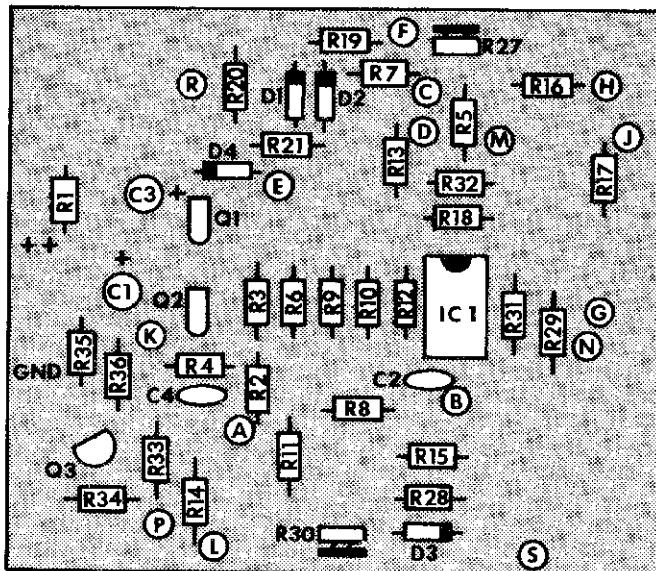

Figure 1

Mount the following electrolytic capacitors and solder them in place. The values, voltage rating and polarization are marked on the body of the part.

DESIGNATION	VALUE
() C1	100 mfd. 16v.
() C3	2.2 mfd. 10v.

Install the transistors. Orient as illustrated in figure 1 and the parts placement designators printed on the circuit board. All semi-conductors are heat sensitive and may be damaged if allowed to get too hot while soldering. To be on the safe side heat sink each transistor lead during the soldering operation by grasping it with a pair of needle nose pliers at a point between the circuit board and the body of the transistor.

DESIGNATION	TYPE NO.
() Q1	2N2712
() Q2	2N2712
() Q3	2N5139

Install the four diodes in the positions shown in figure 1. Note that the diodes are polarized and must be correctly oriented in order to operate properly. Polarization of the diodes is indicated by a colored band on one end of the case. Install as shown in figure 1. The physical appearance of the device is related to the schematic symbol used on the circuit board parts placement designators in the drawing below.

DESIGNATION	TYPE NO.
() D1	1N914
() D2	1N914
() D3	1N914
() D4	1N914

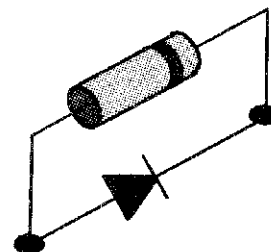

Mount the integrated circuit. Note that the orientation of the integrated circuit is keyed by a notch at one end of the case which aligns with the semi-circular key on the designator printed on the circuit board. Use particular care when installing this part, like any other semi-conductor it is heat sensitive and should not be exposed to extraordinarily high soldering temperatures. Make sure that the orientation is correct before soldering. Once the unit is in place it cannot be removed without destroying it.

DESIGNATION	TYPE NO.
() IC-1	LM-3900 Quad Norton Amplifier or CA3401E

Install the trimmer potentiometers.

() R27	50K
() R30	50K

In the following steps wires will be soldered to the circuit board which will later connect to the front panel controls and jacks. At each step prepare the wire by cutting it to the specified length and stripping 1/4 inch of insulation from each end of the wire. "Tin" each end of the wire by twisting the exposed strands tightly together and melting a small amount of solder into the wire.

Using the wire provided make the following connections to the "A" circuit board:

() a 3 inch length to point "A".	() a 2 1/2 inch length to point "J".
() a 5 inch length to point "B".	() a 4 1/4 inch length to point "K".
() a 3 1/2 inch length to point "C".	() a 5 1/2 inch length to point "L".
() a 6 inch length to point "D".	() a 4 inch length to point "M".
() a 6 1/2 inch length to point "E".	() a 2 1/2 inch length to point "N".
() a 4 inch length to point "F".	() a 7 inch length to point "R".
() a 2 1/2 inch length to point "G".	() a 5 1/4 inch length to point "P".
() a 2 1/2 inch length to point "H".	() a 2 1/2 inch length to point "S".

THIS COMPLETES ASSEMBLY OF THE 4740 "A" CIRCUIT BOARD. TEMPORARILY SET THE BOARD ASIDE AND PROCEED WITH THE ASSEMBLY OF THE SMALLER "B" CIRCUIT BOARD.

The 4740 "B" circuit board is used to mount the MLS-750 Light Emitting Diodes to the front panel.

- () Thoroughly scour the smaller "B" circuit board, rinse with clear water and dry.
- () Melt a small amount of solder on each of the square pads on the 4740 "B" circuit board. This solder will aid in making connections from the 4740 "A" board in a later step.

You are now ready to mount the Light Emitting Diodes. First examine this part carefully and note that one of the leads is marked with a color band. Observe that the rear side of the case of the LED is flat, while the front side is roughly dome shaped. In a later step the dome shaped front of the packages will mate with holes in the front panel.

Bend the leads loosely back. DO NOT use pliers to form a right angle bend in the leads. Make sure that the unbanded lead goes through the hole marked "-". Fold the LED leads tightly against the so pads of the circuit board and lightly solder. Clip off excess leads after soldering.

DESIGNATION	TYPE NO.
() LED-1	MLS-750
() LED-2	MLS-750

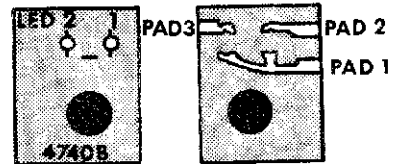

THIS COMPLETES ASSEMBLY OF THE 4740 "B" CIRCUIT BOARD. TEMPORARILY SET THE BOARD ASIDE AND PROCEED WITH THE FRONT PANEL ASSEMBLY.

Place the front panel face down on a soft rag to prevent marring the finish.

- () Place a red pin jack (J2) in the hole provided as shown in fig. 4. Fasten in place with a tinnerman nut as shown in detail figure 2. Press the tinnerman nut down firmly.
- () In a similar manner mount red pin jack (J3) as shown in figure 4 and fasten in place.
- () In a similar manner mount black pin jack (J1) as shown in figure 4. When installing the tinnerman nut rotate it 90° from the way that it is illustrated in figure 2 to insure adequate space for the 4740 "B" circuit board which will be mounted in a later step.

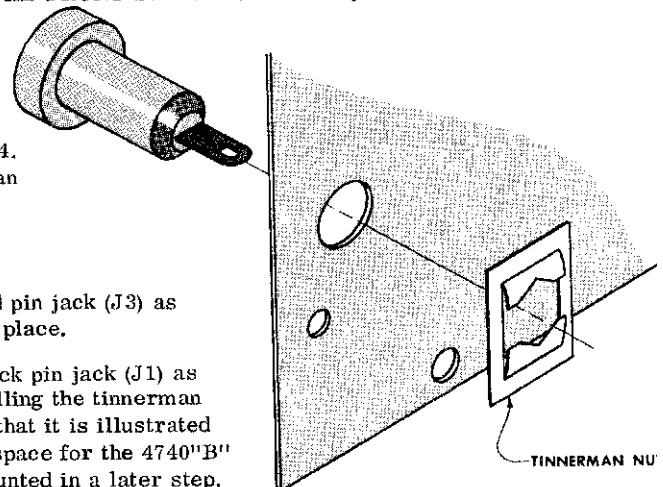

Figure 2

- () Peel the cardboard backing from the two black dots provided. Mount the dots over the LED holes on the back of the front panel as shown in detail figure 3.
- () Mount the LED circuit board 4740-"B" to the front panel using the pushbutton switch, the nut, and lockwasher supplied with it as shown in detail figure 3. Align the two LED's with the two small holes in the front panel then tighten the nut firmly. DO NOT USE EXCESSIVE FORCE.
- () Mount 500K potentiometer R22 in the location shown in figure 4. Use two 3/8 inch nuts, one behind the front panel as a spacer and the second on the front side of the panel to secure the potentiometer. Adjust the rear nut so that none of the threaded shaft of the control is exposed when the front nut is tightened down. This will allow the control knob which will be mounted in a later step to seat as closely as possible to the front panel. Orient as illustrated.
- () In a similar manner mount 500K potentiometer R23 in the location shown in figure 4. Orient as illustrated.
- () In a similar manner mount 5K potentiometer R24 . Orient as illustrated.
- () In a similar manner mount 500K potentiometer R25 in the location shown in figure 4.
- () In a similar manner mount 5K potentiometer R26. Orient as illustrated.
- () Cut a 2 1/4 inch length of bare wire provided.

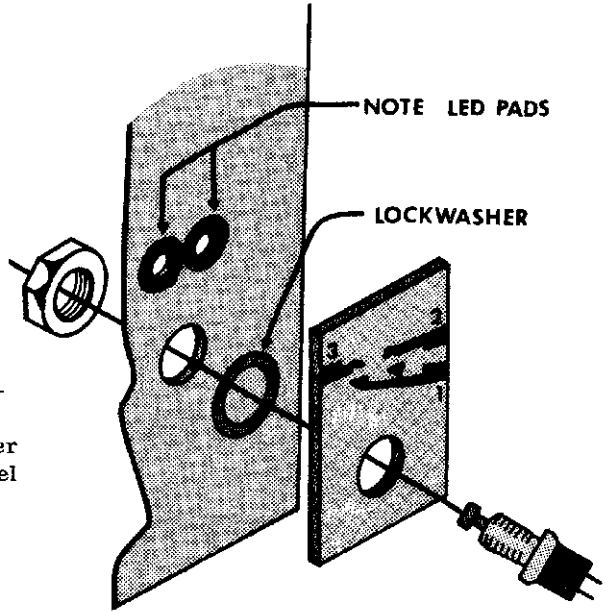

Figure 3

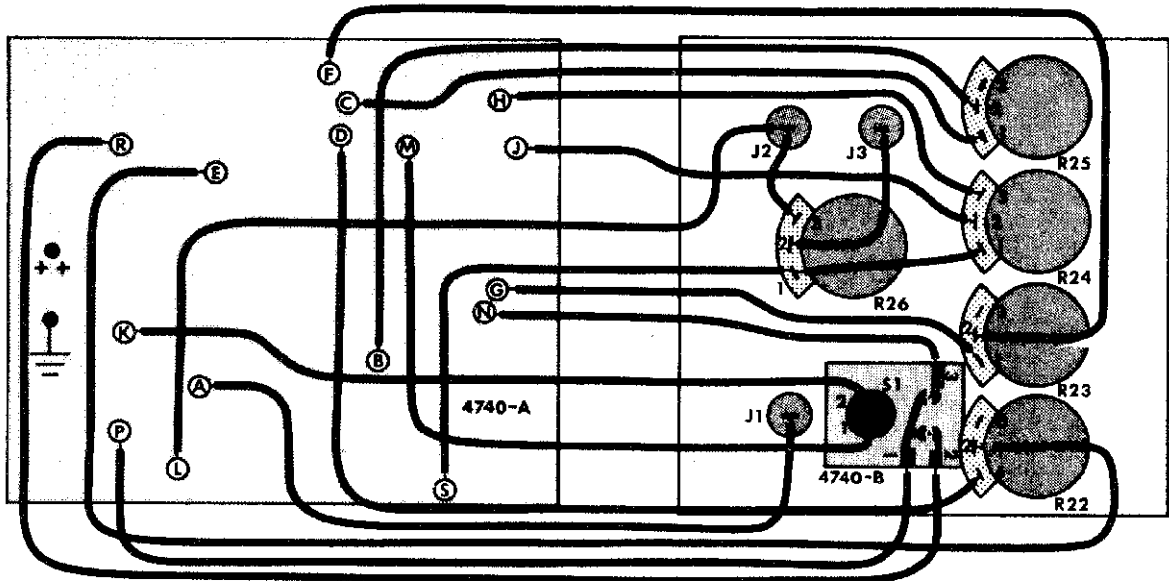
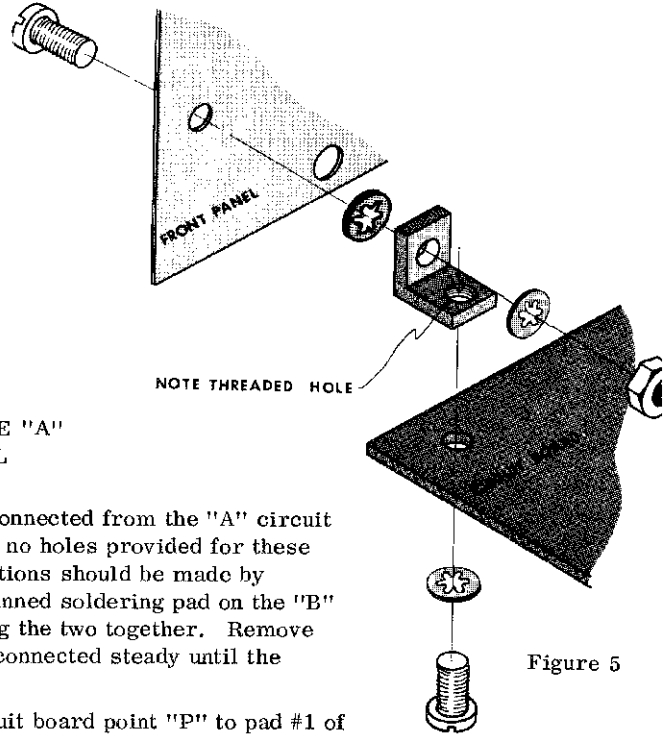

Figure 4

- () Connect the bare wire from lug #1 of R24 to lug #1 of R26. Solder the connection at R24 only.
- () Using a 2 1/4 inch length of insulated wire make the connection between J3 and lug #2 of R26. Solder both connection points.
- () Using a 1 3/4 inch length of insulated wire make the connection between J2 and lug #3 of R26. Solder the connection at R26 only.

THE FRONT PANEL MAY NOW BE BOLTED TO THE CIRCUIT BOARD AS FOLLOWS:

- () Fasten the two "L" brackets to the front panel using one 4-40 X 1/4 inch machine screw, two lockwashers and one 4-40 nut on each bracket. Note that the unthreaded hole in the "L" bracket is used in this operation as shown in figure 5.
- () Fasten the circuit board to the front panel "L" brackets by passing a 4-40 X 1/4 inch machine screw up through the holes in the circuit board and threading them into the threaded holes in the "L" brackets. Securely tighten all screws.



MAKE THE CONNECTIONS BETWEEN THE "A" CIRCUIT BOARD AND THE FRONT PANEL AS FOLLOWS:

In the following three steps wires will be connected from the "A" circuit board to the "B" circuit board. There are no holes provided for these connections on the "B" board. The connections should be made by heating the tinned end of the wire and the tinned soldering pad on the "B" circuit board simultaneously while pressing the two together. Remove the soldering iron and hold the wire being connected steady until the solder cools.

- () Solder the wire coming from circuit board point "P" to pad #1 of the 4740-"B" circuit board as shown in figure 4.
- () Solder the wire coming from circuit board point "N" to pad #3 of the "B" circuit board.
- () Solder the wire coming from circuit board point "R" to pad #2 of the "B" circuit board.
- () Connect and solder the wire coming from circuit board point "H" to lug #3 of R24
- () Connect and solder the wire coming from circuit board point "J" to lug #2 of R24.
- () Connect and solder the wire coming from circuit board point "G" to lug #1 of R23.
- () Solder the wire coming from circuit board point "M" to lug #1 of S1.
- () Connect the wire coming from circuit board point "S" to lug #1 of R26 as shown in figure 4. Solder two wires at this point.
- () Connect and solder the wire coming from circuit board point "F" to lug #2 of R23
- () Connect and solder the wire coming from circuit board point "C" to lug #1 of R25.
- () Connect and solder the wire coming from circuit board point "D" to lug #1 of R22.
- () Connect and solder the wire coming from circuit board point "B" to lug #2 of R25 as shown in figure 4.
- () Connect and solder the wire coming from circuit board point "A" to J1 as shown in in fig. 4.
- () Connect and solder the wire coming from circuit board point "E" to lug #2 of R22.
- () Connect the wire coming from circuit board point "L" to J2. Solder two wires at this point.
- () Solder the wire coming from circuit board point "K" to lug #2 of S1 as shown in figure 4.

- () Rotate all control shafts fully counterclockwise as viewed from the front panel.
- () Once the control knobs are pushed on to their shafts they will be difficult to remove. Before installing the knob align the pointer on the top of the knob so that it is in a 7:00 o'clock position. Push the knob onto the shaft firmly.
- () Two "flea" clips have been included to facilitate power supply connections. Insert these clips in the holes at the end of the circuit board marked "++" and " $\frac{\ominus}{\oplus}$ ". These clips are a tight fit, it may be necessary to bend the narrow end of the clips slightly to fit the holes.

THIS COMPLETES ASSEMBLY OF THE 4740 ENVELOPE GENERATOR.

TESTING AND CALIBRATION

Instrumentation required to test and calibrate the 4740 Envelope Generator is minimal. You will need a Volt-Ohm Meter (VOM) and a working Voltage Controlled Oscillator (VCO). The output of the VCO must be made audible by connecting to an external Hi-Fi or instrument amplifier.

SET-UP

Initial equipment connections should be as shown in figure 6. Connect a +18v. supply to the ++ power connection on the rear edge of the 4740 circuit board and ground to the ($\frac{\ominus}{\oplus}$) connector. Patch the fixed output of the 4740 (lower right hand pin jack) to one of the control voltage inputs of the VCO. Connect the VOM between the variable output (upper right hand pin jack) and ground and set to a scale on which you can conveniently read 5v. Set the 4740 front panel controls as follows: ATTACK - full clockwise (CW), DECAY - full counter-clockwise (CCW), SUSTAIN - full CW, RELEASE - full CCW, LEVEL - full CW.

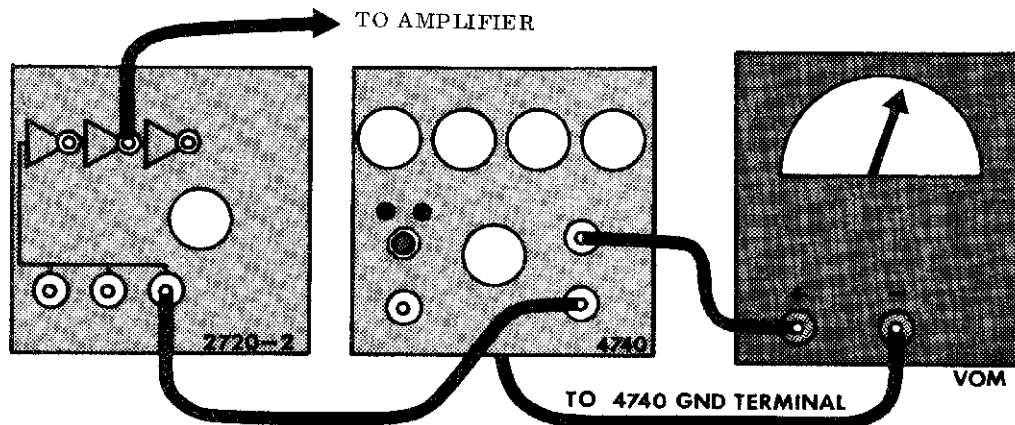

Figure 6

Momentarily press the red "trigger" button and observe that the attack status indicator (left hand LED designated as "A") goes on and stays on for a period of from 1 to 2 seconds before going off. As long as the trigger button is not held down the decay/sustain indicator (right hand LED designated as D/S) should not light. Press the trigger several times to make sure that the attack indicator lights each time the button is pressed.

Press the trigger button and hold it down. Observe that the attack indicator lights for a period of from 1 to 2 seconds then extinguishes as the decay/sustain indicator comes on. Observe that the decay/sustain indicator remains on as long as the trigger button is held down and extinguishes when the trigger button is released.

With the front panel controls still set as above, set the internal trimmer potentiometers R27 (PEAK AMP.) fully CW as viewed from the nearest edge of the circuit board and R30 (SUSTAIN TRIM) fully CCW as viewed from its nearest board edge. Bring up the volume on the VCO amplifier so that a sweeping tone can be heard whenever the trigger button of the 4740 is pressed.

Press and hold the trigger button and observe that the VCO slowly sweeps up to a peak frequency and then steps back down to a lower sustained pitch. This indicates that the range of the front panel sustain control does not correspond with the peak output of the rest of the circuitry but is a normal condition for the unit prior to final calibration. Release the trigger button and observe that the oscillator returns to a low frequency (or possibly goes off entirely). Successful completion of these preliminary tests indicate that the module is ready for final calibration.

CALIBRATION

During calibration, two key parameters will be brought up to specification. The peak output of the 4740 will be set to 5v. and the front panel SUSTAIN control will be trimmed so that at its maximum setting the sustain voltage will correspond with the peak output level of the module.

Press and hold the trigger button while watching the VOM. The meter pointer should deflect upwards and settle at a reading of less than 5v. Slowly turn the adjusting disk of R30 (SUSTAIN TRIM.) CW until the meter shows that the output of the envelope generator is 5v. There is a slight lag between changes in the setting of R30 and resulting changes in the output voltage so make only small, slow changes in adjusting this control.

Bring up the volume of the amplifier connected to the VCO again and listen to the tone produced by pressing and holding the trigger button. At this point it should still rise to a peak frequency and then step down to some sustaining level, indicating that the maximum sustain level setting does not correspond with the peak output of the module. Adjust trimmer R27 (PEAK AMP.) in a CCW direction until pressing and holding the trigger button produces a tone that slowly glides up-scale and then steps without stepping down in pitch. Too much CCW rotation of R27 will cause the pitch to rise to some frequency and then continue to rise further at a very slow rate.

USING

The 4740 ADSR Envelope Generator has essentially 4 separate states with key parameters for each state independently controllable. The four states are: Attack, Decay, Sustain and Release. It is important to notice that three of these four parameters are times (attack, decay, release) while only one is a voltage level (sustain). Figure 7 illustrates a typical output waveform and relates the standard nomenclature to the changes in voltage that occur during the four states of a complete cycle. Also illustrated are the conditions of the Light Emitting Diode status indicators for each state.

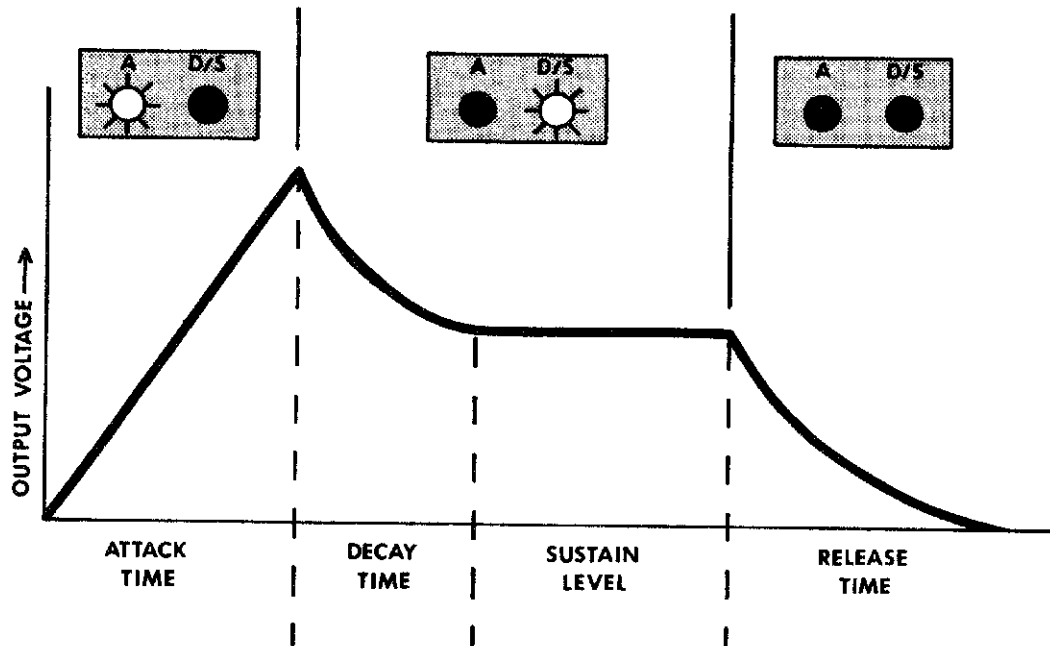

Figure 7

FRONT PANEL CONTROLS

For ease of explanation we will break the front panel control down into four major categories; triggering, status indicators, output, and parameter controls. These categories also correspond to the symbolic grouping of controls within the front panel graphics.

TRIGGERING

Manual Trigger The red push-button inside the trigger box provides a means of testing the 4740 as well as a convenient way to trigger the module when it is being used in applications where there is no voltage trigger available. Pressing this button causes the module to complete the attack and decay portions of the cycle and hold at the sustain level for as long as the button is held down. Releasing the button completes the cycle by allowing the circuitry to pass into the release state.

Electrical Trigger A constant voltage greater than 3.5 volts applied to the black pin jack directly below the manual trigger button causes the module to cycle through the attack and decay states and hold at the sustain level. Removing the triggering voltage or allowing it to fall below 3.5 volts causes the circuitry to complete the cycle by passing into the release state. A triggering pulse that is of shorter duration than the attack cycle will cause the output of the module to pass through the attack, decay and release states without holding at the sustain level. The module may be re-triggered any time the attack status indicator is not lit.

STATUS INDICATORS

A The Attack status indicator light (labeled A) indicates that the 4740 is in the attack portion of the ADSR cycle.

D/S The Decay/Sustain indicator lights when the 4740 is in the decay or sustain portion of the ADSR cycle.

OUTPUTS

Fixed Output The lower red pin jack in the output box is a fixed level output. The voltage at this jack will always rise to the nominal 5 volts peak output at the end of the attack state before continuing through the rest of the cycle.

Variable Output The upper red pin jack in the output box is connected through front panel level control. Outputs at this pin jack happen at the same rate as those at the fixed output but the complete ADSR waveform may be scaled down in amplitude to meet specific requirements.

Level The control in the center of the front panel sets the overall amplitude of the ADSR waveform that appears at the variable output pin jack described above. At the extreme counter-clockwise rotation of this control there will be no control voltage present at the variable output. Clockwise rotation of the control uniformly increases both peak amplitude and sustain level.

PARAMETER CONTROLS

Attack The attack control sets the time required for the output voltage to rise to the peak point on the ADSR waveform. Clockwise rotation of this control varies the attack time from a minimum of 2 ms. to a maximum of 1.5 seconds.

Decay The Decay control sets the time required for the ADSR waveform to fall from its peak back down to the sustain level. The times involved in the setting of this control are dependent on the setting of the sustain control (the higher the sustain level, the less "distance" needs to be traveled) but assuming a zero voltage sustain level the decay time is variable from 2 ms. at the extreme counter-clockwise limit of the control to 1.5 seconds at the clockwise limit.

Sustain The sustain level control sets the output voltage that will be present while the ADSR is holding in the sustain state. At the extreme CCW limit of this control the output voltage will sustain at some very low level - on the order of .5 volts or less - and at the CW limit the sustain voltage will be the same as the peak value attained at the completion of the attack state.

Release The release control sets the time required for the output voltage to fall from the sustain level back to zero output. Like the decay setting, total times are dependent on the setting of the sustain control but assuming maximum sustain level this time is variable from 2 ms. to 1.5 seconds and increases with clockwise rotation of the control.

As is covered in the PAIA 2720 User's Manual, one of the chief characteristics that enables a listener to distinguish one instrument from another is dynamics - in what way and how fast the sound builds up and dies away. Perfect examples of this are flutes and drums. Everyone knows that a flute doesn't sound anything like a drum but the fact is that the basic waveshape of both instruments is very close to a sine wave. A flute has a relatively long attack by the standards of most instruments because it takes a certain amount of time for the vibrations of the air mass in the body of the flute to build up. A drum on the other hand immediately produces its maximum amplitude as soon as the head is struck. A flute sustains for as long as the musician can keep his wind and the drum sound begins to decay

immediately. These are the only things which give the drum its "hard" sound as opposed to the "soft" sound of the flute.

In a synthesizer these repeatable changes in sound intensity are produced by varying the gain of a Voltage Controlled Amplifier - and the Envelope Generator is the module that provides the time varying voltage that controls the amplifier.

For the most realistic drum percussion effects the 4740 should be triggered with a short duration pulse and the parameter controls set for short attack and decay, some intermediate setting of sustain level and medium release. Exact values of these settings are more or less a matter of personal taste but the output of the envelope generator will look something like figure 8. Woodblock type percussion would be an envelope such as is shown in figure 9. The parameter control settings are for the most part identical to the drum type percussion except that the release control is rotated fully counter-clockwise for the shortest possible release time. Flute sounds require a sustaining waveform such as the one shown in figure 10. Here a voltage step that stays high for a manually determined length of time is the triggering function and the parameter controls are set with relatively rapid release. Note that in this case the setting of the decay control is irrelevant since as long as the sustain control is set fully CW there is no initial decay period.

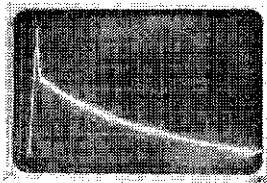

Figure 8

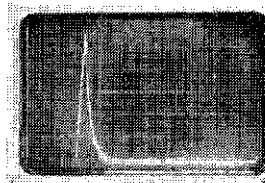

Figure 9

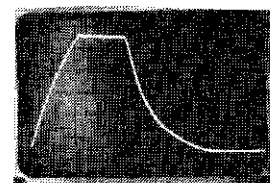

Figure 10

Figure 11 shows an envelope that you don't encounter much in non-electronic instruments - a percussion leading edge followed by a manually determined sustain plateau. On natural instruments such as flute, reed instruments and brass this is an effect that requires considerable practice to master but with an Envelope Generator it's simply a matter of triggering from a voltage step and setting parameter controls for fast attack and decay, intermediate sustain level and moderately fast release time to suit the desired effect.

There is naturally not enough space here to cover all the possible settings of the parameter controls, a little practice and experimentation will quickly familiarize you with the effects produced by the various settings of attack, decay, sustain and release.

Manual controllers are not the only possible trigger sources for the 4740. As shown in figure 12 repeating waveforms of various types can be generated by using a slow speed oscillator as the repeating trigger source. In this case the waveform illustrated is along the lines of the envelopes produced by telephone bells and other repeating chimes. By juggling the level controls of the low frequency oscillator the 4740 can be made to trigger at various points on the input waveform to produce envelopes with shorter or longer sustain plateaus than those shown.

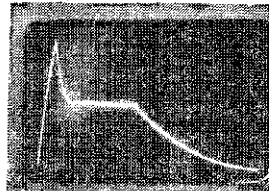

Figure 11

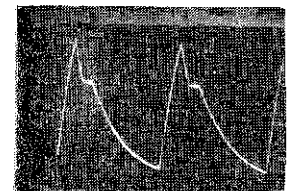

Figure 12

One 4740 can be used to trigger another and this presents interesting possibilities for very complex envelopes. In this application one Envelope Generator can be designated as the master with subsequent generators designated slave units. The initial trigger source to the master 4740 will be the step or pulse triggers of a keyboard or other controller with slave units triggered from the variable output of the master generator. Once again, juggling the setting of the level control of the master unit determines the point at which the slave unit will trigger. Typical of the effects that might be produced this way would be to have the master generator set to a long attack time with the slave unit triggering at the very peak of the master unit's output. This arrangement could produce envelopes that would rise gradually and then suddenly have a percussive peak as the second generator triggers. Control voltages from the two Envelope Generators could be summed into a single VCA or broken down to control two VCA's each being driven from a separate signal source (such as triangle to one and pulse to another) to bring in higher order harmonics as the total envelope progresses in time. The output of one Envelope Generator could control a VCA while the output of the second swept a filter - and so on.

As always, experimentation is the key to understanding the almost unlimited variety of effects that are possible with a synthesizer.

DESIGN ANALYSIS

The PAIA 4740 Envelope Generator is built around an LM3900 Quad Norton Amplifier. Analysis of this integrated circuit is beyond the scope of this text, but it should be sufficient to say that a Norton Amplifier is a type of operational amplifier that is current sensitive rather than voltage sensitive.

Before triggering, the circuitry is in a stable state with the output of A1 and A2 near ground, the output of A3 near supply, C3 discharged and the voltage at the emitter of Q2 near ground for an essentially zero voltage output.

When the trigger button is pressed, or an external voltage is applied to the triggering input of the module, the current flow through R3 into A1's "+" input causes this amplifier to switch to a high level. As A1 switches, a short duration pulse is coupled through C2 and appears across R8 which causes a current flow through R9 into the "+" input of A2. A2's output now goes from near ground to near supply and current fed back from the output through R12 into the "+" input holds this amplifier in a high state. At this point, the trigger signal could be removed and there would be no change in the circuit because A1's output is held in a high state by the feed-back current from the output of A2 through R6 into A1's "+" input.

With A2's output near the supply voltage, D4 is forward biased and current can flow into C3 through R13 and R22. R22 sets the current flow and consequently the rate at which C3 charges. The voltage across C3 is sensed by the darlington pair emitter follower comprising Q1 and Q2 so that the voltage at the emitter of Q2 rises along with the capacitor voltage.

Eventually, the voltage at the emitter of Q2 rises to the point that the current flow through R11 when added to the bias current through R27 and R10 exceeds the feed-back current through R12 and at this point the output of A2 switches back to near ground. D4 is now reverse biased so no current can flow from C3 back into the output of A2.

While A2 was high, current flow through R18 into the "+" input of A3 caused the output of this amplifier to be near supply. Now that this current is absent, the current flow into the "-" input of A3 through R15 exceeds the current through R17 into the "+" input and the output of this amplifier switches low causing current to drain from C3 through R23, R19 and D1 which is now forward biased. C3 discharges at the rate set by R23 until the current through R15 and R17 are equal. With A3's two input currents equal the output of this amplifier stage rises to whatever voltage is required to keep the currents equal. R20 and R21 provide a high resistance feed-back path that "closes the loop" for A3. When the module is not working and the output of A1 is near ground, diode D3 clamps the middle of this loop to ground so that there is no current leakage into C3. During the times that the output of A1 is high (so that D3 is reverse biased) the current flow through these high value resistors is so small compared to the working currents charging and discharging C3 that it can be ignored.

The circuitry is now in a second stable state with the output of A1 high, A2 low and A3 at some intermediate level as set by the front panel sustain control.

When the trigger voltage is removed the circuit begins to work again and the removal of the current through R3 causes A1 to switch low. C3 now begins to discharge through R25, R7 and D2 at the final decay rate set by R25. If the trigger input had been removed while the module was still in the attack cycle the output of A1 would have remained high as explained earlier until the attack cycle was complete. At that point both A3 and A1 would switch low and current from C3 would be drained through both of these amplifier outputs. As the output voltage passed through the sustain level, A3 would switch high removing this discharge path so that C3 would continue to discharge toward zero volts at a rate set by R25 only.

LED 2 is the attack indicator light and is on whenever the output of A2 is high. LED 1 is the decay/sustain indicator lamp which is on when the current through R29 exceeds the sum of the currents through R31 and R32, a situation that only happens when the output of A1 is high and A2 is low.

R33 is a current limiting resistor for the light emitting diodes. During the times that neither of the status indicators are lighted, the lack of voltage across R33 causes transistor Q3 to conduct. As Q3 switches on and off it causes a current flow through the "dummy load" R35. This current is of about the same magnitude as the current drawn while the LEDs are on and consequently serves to keep the current drawn by the 4740 from the power supply relatively constant regardless of the ADSR's status. This constant current drain reduces power supply regulation requirements.

C4 is an integrating capacitor to keep noisy trigger inputs from producing multiple triggers.

R1 and C1 provide power supply decoupling.

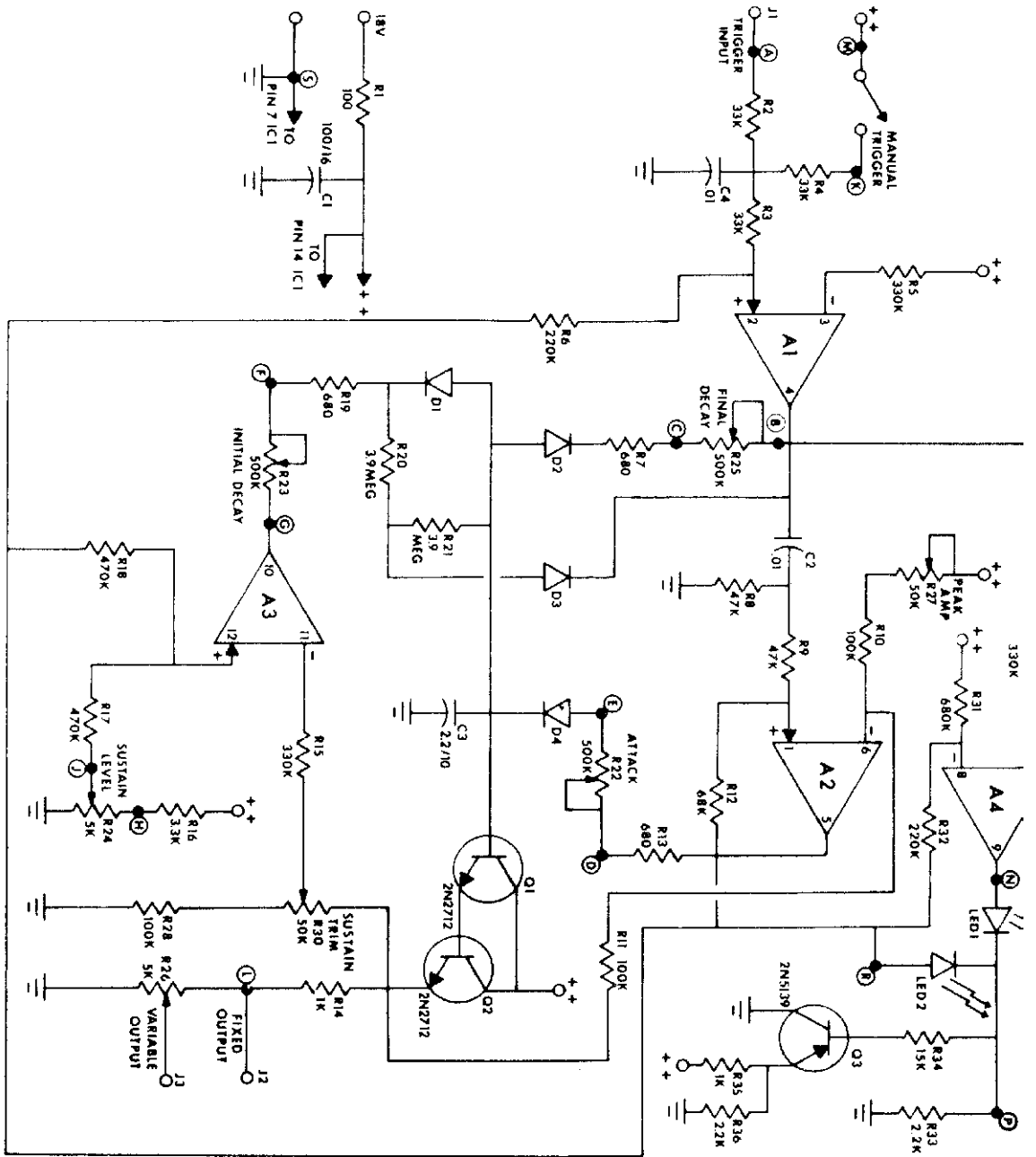

Figure 13