



# **SPB-8**

## **STEREO PEDAL BOARD**

# ***FURMAN***

## **OWNER'S MANUAL**

## SPB-8 Features

- The Pedal Board is a solid, nonslip base for pedal effects that lets you leave everything powered up and patched together as you like it
- Toroidal transformer for ultra low-noise performance
- Pedal effects attach securely to a 12" x 25" Velcro pad
- Sturdy, roomy, padded travel case fits the Pedal Board plus attached effects, includes shoulder strap and zippered pouch
- Stereo effects return, effects loop, and amplifier outputs
- Eight individually protected 9VDC outlets, with 8 included power cords
- Three widely spaced 120VAC, 15A outlets allow enough room for "wall warts" (E Version 230VAC, 10A outlets)
- Furman's quality spike and surge suppression and EMI/RFI filtering assures clean power
- Rugged construction will withstand years of on-stage use and abuse
- Very long 10-foot AC cord (E Version needs Plug Attachment)

## Introduction

Congratulations on your purchase of the Furman SPB-8/E — the first Pedal Board designed with the professional guitar and bass player in mind. The SPB-8/E is the most rugged, versatile, and useful board available anywhere. It features heavy duty construction that will handle the most forceful stomps you can offer, as well as stand up to the rigors of the road. The first stereo board on the market, it is also the first to feature the high level of power conditioning that Furman is famous for.

At the heart of the SPB-8/E Stereo Pedal Board is a light yet rugged polycarbonate platform in combination with a steel chassis and an ample 12" x 24" Velcro sheet, ensuring secure, noiseless, flex free, nonslip performance for up to eight (or more, depending on power requirements) effects boxes and pedals.

The SPB-8/E's stereo patch bay contains seven 1/4" switching phone jacks and three non-switching

jacks, connected in two mono loops. This allows a single guitar or instrument input to feed multiple mono and stereo effects boxes, send and return from remote effects, and feed up to two amplifiers simultaneously. From modest to highly complex patching demands, the SPB-8 allows nearly unlimited setup flexibility.

Powering your pedals, amps and other gear, the SPB-8/E offers two levels of surge and short circuit protection, as well as RF and EMI filtering. The SPB-8/E is quiet, powering both AC and DC pedals without hum, due to the high quality toroidal transformer employed. Each DC output is rated at 100 mA, as well as being individually protected against shorts — guaranteeing that if one pedal goes out, the rest are still protected and will continue to function.

The SPB-8/E makes pack-up simple and convenient. Unpatching several effects boxes and pedals is no longer required, since the large Velcro sheet and included mating strips firmly secures all of your pedals in place. A sturdy, padded case is included and comes with a handle, a detachable shoulder strap, and two zippered pouches for storing cables, wall warts, and AC cords.

## Using the SPB-8/E

When fully set up, the SPB-8/E will save you many hours of plugging, unplugging, packing, and unpacking pedals and effects. However, to fully realize the simplification it offers, you must do some planning and preparation.

**1. Prepare Pedals:** Most pedal effects have rubber feet on their bottoms. These must first be removed to allow them to be attached to the SPB-8/E. Some may be attached with screws; others may be stick-on types that must be pried off. Once the rubber feet are off, they should be replaced with the adhesive-backed Velcro supplied with the SPB-8/E. Cut suitably-sized pieces with a pair of scissors, peel off the protective backing to expose the adhesive, and stick them to the bottoms of your pedal effects. If you wish to reposition your pedals, several smaller pieces of Velcro may allow easier removal than one large piece, though the larger the area you cover, the more firmly the pedal will be attached.

**2. Create a layout:** Lay out your pedal effects in the desired order, giving thought to such issues

as keeping signal levels high to minimize hum and noise, and ease of access to all foot switches. The Velcro system of attachment allows pedals to be repositioned if necessary. Individual pedals should be connected in a signal chain using short patch cords (not supplied). The input to the first pedal should be patched to the **To Pedal (Input)** jack on the SPB-8/E; the output of the last pedal should be patched to either of the **From Pedals** jacks (both should be used if the pedal has a stereo output). See the next section for more on the SPB-8/E's patching capabilities.

**3. Provide Power:** The SPB-8/E can power almost any pedal made, using one of its four power options. Three of these provide 9 VDC power, and the fourth is 120 VAC "wall" power (E Version 230 VAC Wall outlet).

**9 VDC Power** is typically used in pedals that can run off batteries, or off battery eliminators. The SPB-8/E provides eight 9 VDC power outlets, all of which use 3.5 mm "miniplug" connectors on the pedal board end. On the pedals themselves, several connector types may be used, the most common of which is called "P205L" or "DC connector". This may easily be recognized as a 5 mm round hole (often in a block of black plastic insulating material), with a single metal pin in the center. Eight miniplug-to-DC cables are provided with the SPB-8/E. Some 9V pedals use a miniplug connector instead of a DC connector. One miniplug-to-miniplug cable is provided with the SPB-8/E for such pedals. Finally, a few pedals have no provision for any form of power other than batteries. Should you encounter one of these, one miniplug-to-battery-clip cable is also provided. To use it, simply remove the battery and connect the pedal's battery clip to the one on the cable.

Each of the SPB-8/E's DC power outputs is individually fused and protected against shorts, so pedals can be plugged in without risk even while the pedal board is powered up. Each output can supply up to 100 mA, which should be adequate for virtually any pedal. Because the SPB-8/E is protected by Furman's famous power conditioning capability, your valuable pedals will be protected from damage from spikes and surges.

**120 VAC Power** may be needed for a few pedals. Three grounded, 15A outlets are provided. These may also be used for non-pedal effects, such as those mounted in racks.

**4. Packing up:** Once all pedals have been positioned, linked in a signal chain, and powered, the SPB-8/E is ready for use on stage. After use, the entire unit *with pedals and all cabling attached* may be slipped into its padded Cordura case and transported. An internal strap holds the pedal board in place. The case has both a handle and a detachable shoulder strap for easy carrying. There are also two internal zippered pouches for cables and other accessory items.

## Sample Hookups

The SPB-8/E offers very flexible patching options that will allow easy connection of mono and/or stereo pedal effects, rack effects, and instruments and amps. Several examples are presented here to illustrate its capabilities. To understand the patch bay, consider the "normal" signal flow through it, indicated by the dotted lines with arrows showing direction:

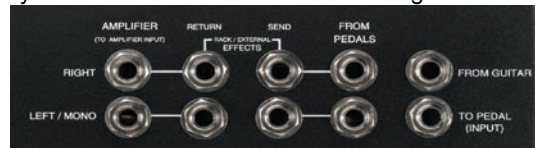

Note that there are two channels, **Left/Mono** and **Right**. If nothing is plugged into the switching jacks (marked "S"), signal will flow unimpeded from the first jack (**From Guitar**, for Left/Mono, or **From Pedals**, for Right) to the last jack (**Amplifier**, for both Left/Mono and Right) in each channel. Each of the three jacks marked "U" is unswitched and may be used to take a "tap" off the signal path without breaking it, provided the jack to its immediate left is unused.

All hookups begin by connecting the guitar or other instrument into the **From Guitar** jack, and the input to the first pedal in the pedal chain to the **To Pedal (Input)** jack. From there, the exact hookup used depends on whether the pedals have mono or stereo outputs, whether rack effects as well as pedals are used, and whether one or two amps are used.

## Example 1: Mono Pedals, Single Amp

In this example, two pedals are linked together with a short cable going from the output of the first to the input of the second. Since there is only one amp, only the Left/Mono channel is used.

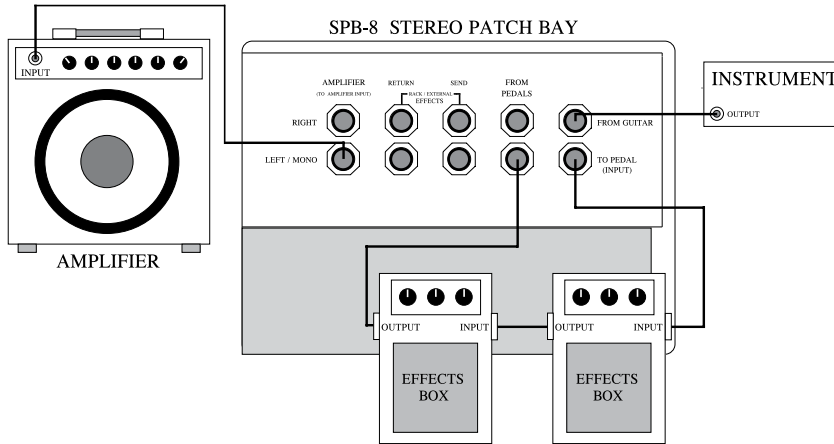

## Example 2: Mono Pedals, Two Amps

This example is similar to the first except there are two amps. Both the **Left/Mono** and **Right** channels are used, and receive identical signals to send to their respective amps. The feed to the **Right** channel is split off from the Left/Mono signal path using the **Left/Mono Rack Effects Send** jack, because plugging in to either of the **Send** jacks allows a “tap” to be taken without breaking the corresponding signal path.

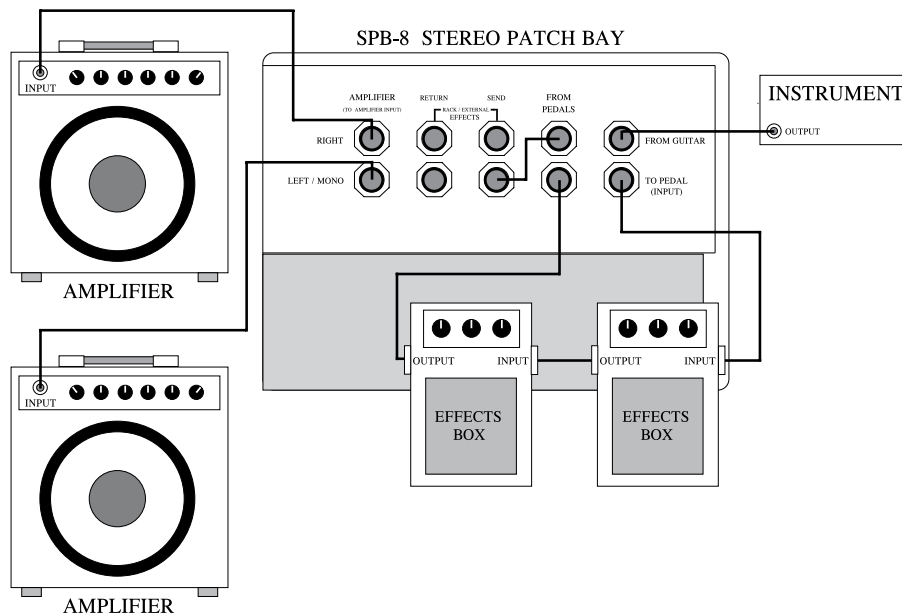

### Example 3: Mono Pedals, Stereo Rack Effects, Two Amps

This example is similar to the previous one except a rack effect is added which has one input and two (stereo) outputs. Again, both channels are used, but the left/right split is generated by the stereo rack effect.

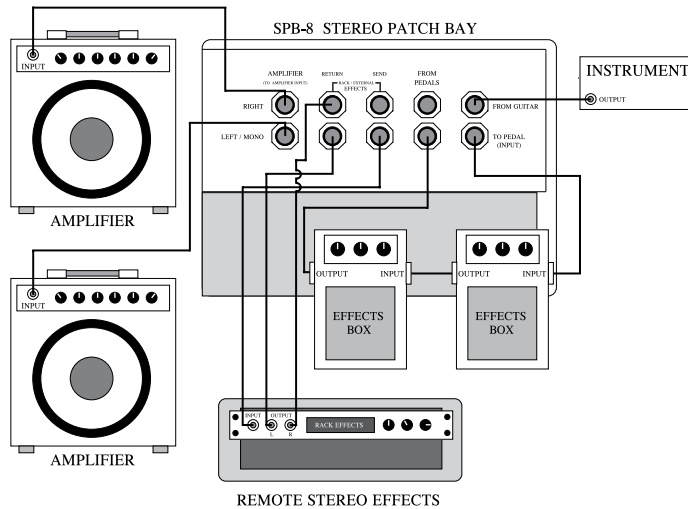

### Example 4: Mono Pedals, Mono Rack Effects, Two Amps

In this example, both the pedals and the rack effect are mono, so the left/right split to feed the two amps is accomplished similarly to Example 2, in which a **Rack Effects Send** jack was used to tap off a copy of the signal. Note that in this case the pedal chain's output is plugged to the Right channel, so it is the **Right Rack Effects Send** that is the splitting element. Because the jumper cable from the **Right Rack Effects Send** is plugged into the **Left From Pedals** jack, the "normal" signal path through the left channel is broken and replaced with the signal from the right channel. Also, note that while the pedal effects are heard in both channels, the rack effects would only be heard in the left channel.

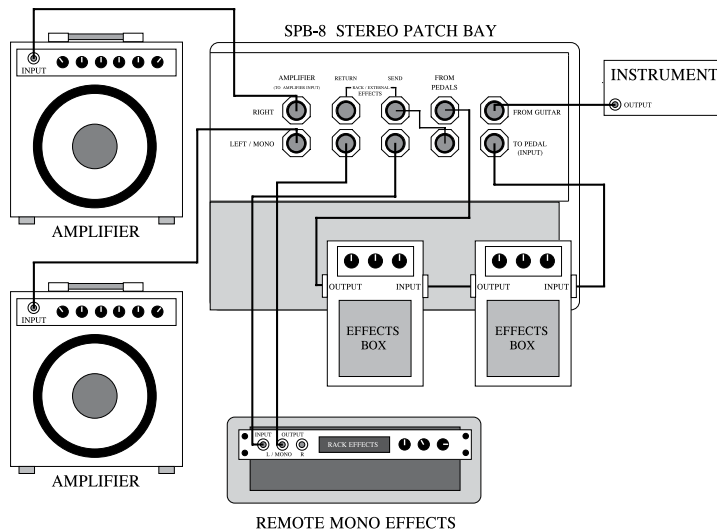

### Example 5: Mono Pedals, Mono Rack Effects, One Amp

In this example, you have both pedals connected to the input of your amplifier while using remote mono effects (which can be pedals or racked effects) connected to your amplifier's effects loop. You can only connect one amplifier to the patchbay with this configuration.

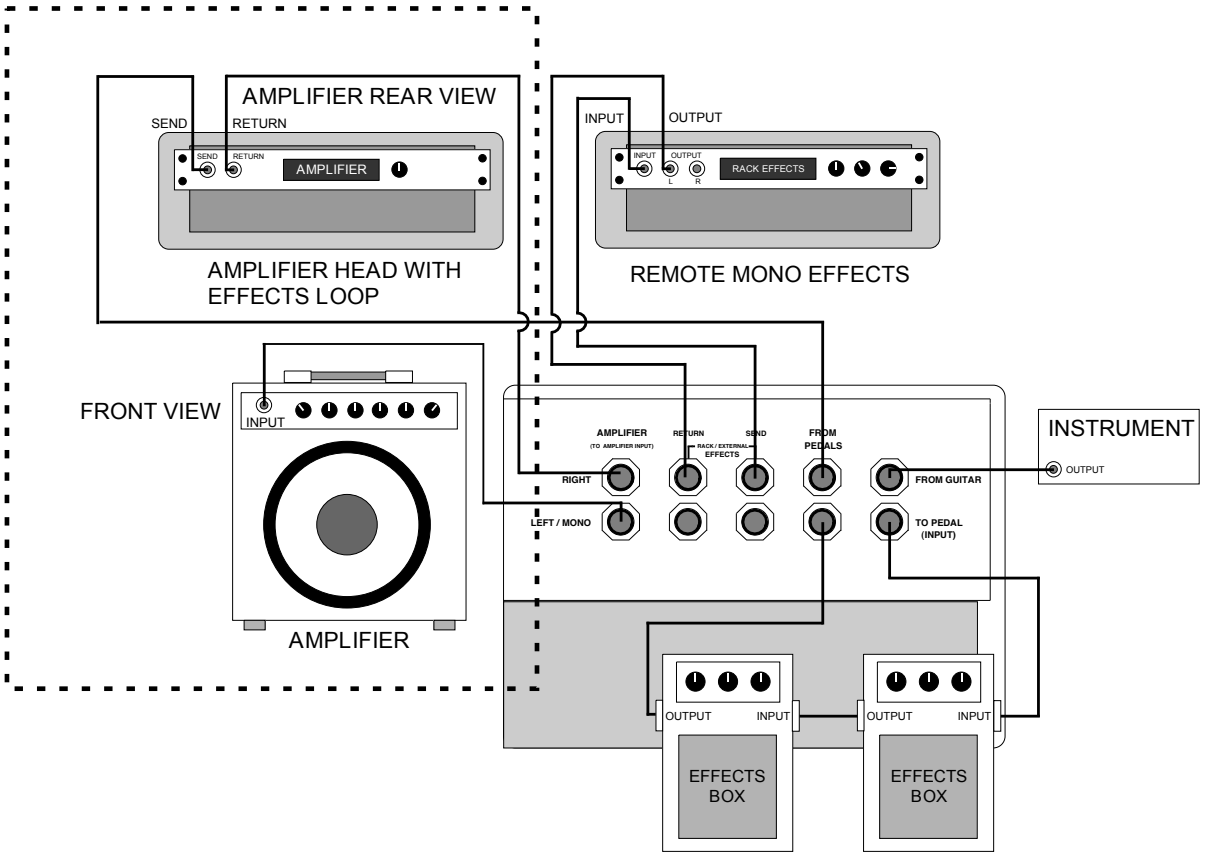

## **A Note On The Current Requirements Of Pedal Effects**

Each of the SPB-8/E's 9VDC outlets has a maximum current rating of 100 mA, yet certain pedals state power requirements of 200 mA or more. Most of the time, these specifications are more indicative of a desired level of regulation from a wall wart than an actual *constant current* requirement. Typically, the actual current draw is no more than 50 mA, so the SPB-8/E's supply will in fact be more than adequate. To confirm this, try it! There is no harm in trying one of the SPB-8/E's 9VDC outlets on *any* pedal or box. If the constant current draw actually exceeds 100 mA, the PTC (solid state fuse) will shut off, without damage, until the excessive load is removed. If this occurs, simply unplug the device and use one of the SPB-8/E's AC outlets with an appropriate wall wart supply. To further illustrate this point, consider this: If a battery-powered device were actually to draw 300 mA continuously at 9VDC, it would consume a new alkaline battery every *six minutes*.

## **Three Year Limited Warranty**

Furman Sound, Inc., having its principal place of business at 1997 South McDowell Blvd., Petaluma, CA 94954 ("Manufacturer") warrants its SPB-8 (the "Product") as follows:

Manufacturer warrants to the original Purchaser of the Product that the Product sold hereunder will be free from defects in material and workmanship for a period of three years from the date of purchase. The Purchaser of the product is allowed fifteen days from the date of purchase to complete warranty registration by mail or on-line at the Furman website. If the Product does not conform to this Limited Warranty during the warranty period (as herein above specified), Purchaser shall notify Manufacturer in writing of the claimed defects. If the defects are of such type and nature as to be covered by this warranty, Manufacturer shall authorize Purchaser to return the Product to the Furman factory or to an authorized Furman repair location. Warranty claims should be accompanied by a copy of the original purchase invoice showing the purchase date; this is not necessary if the Warranty Registration was completed either via the mailed in warranty card or on-line website registration. Shipping charges to the Furman factory or to an authorized repair location must be prepaid by the Purchaser of the product. Manufacturer shall, at its own expense, furnish a replacement Product or, at Manufacturer's option, repair the defective Product. Return shipping charges back to Purchaser will be paid by Manufacturer.

THE FOREGOING IS IN LIEU OF ALL OTHER WARRANTIES, EXPRESS OR IMPLIED, INCLUDING BUT NOT LIMITED TO THE IMPLIED WARRANTIES OF MERCHANTABILITY AND FITNESS FOR A PARTICULAR PURPOSE. Manufacturer does not warrant against damages or defects arising out of improper or abnormal use of handling of the Product; against defects or damages arising from improper installation, against defects in products or components not manufactured by Manufacturer, or against damages resulting from such non-Manufacturer made products or components. This warranty shall be cancelable by Manufacturer at its sole discretion if the product is modified in any way without written authorization from Furman Sound. This warranty also does not apply to Products upon which repairs have been affected or attempted by persons other than pursuant to written authorization by Manufacturer.

THIS WARRANTY IS EXCLUSIVE. The sole and exclusive obligation of Manufacturer shall be to repair or replace the defective Product in the manner and for the period provided above. Manufacturer shall not have any other obligation with respect to the Products or any part thereof, whether based on contract, tort, strict liability or otherwise. Under no circumstances, whether based on this Limited Warranty or otherwise, shall Manufacturer be liable for incidental, special, or consequential damages. Manufacturer's employees or representatives' ORAL OR OTHER WRITTEN STATEMENTS DO NOT CONSTITUTE WARRANTIES, shall not be relied upon by Purchaser, and are not a part of the contract for sale or this limited warranty. This Limited Warranty states the entire obligation of Manufacturer with respect to the Product. If any part of this Limited Warranty is determined to be void or illegal, the remainder shall remain in full force and effect.

# ***FURMAN***

Furman Sound, LLC.  
1690 Corporate Circle.  
Petaluma, California 94954-6919 USA  
Phone: 707-763-1010  
Fax: 707-763-1310  
[www.FurmanSound.com](http://www.FurmanSound.com)