

Service Manual

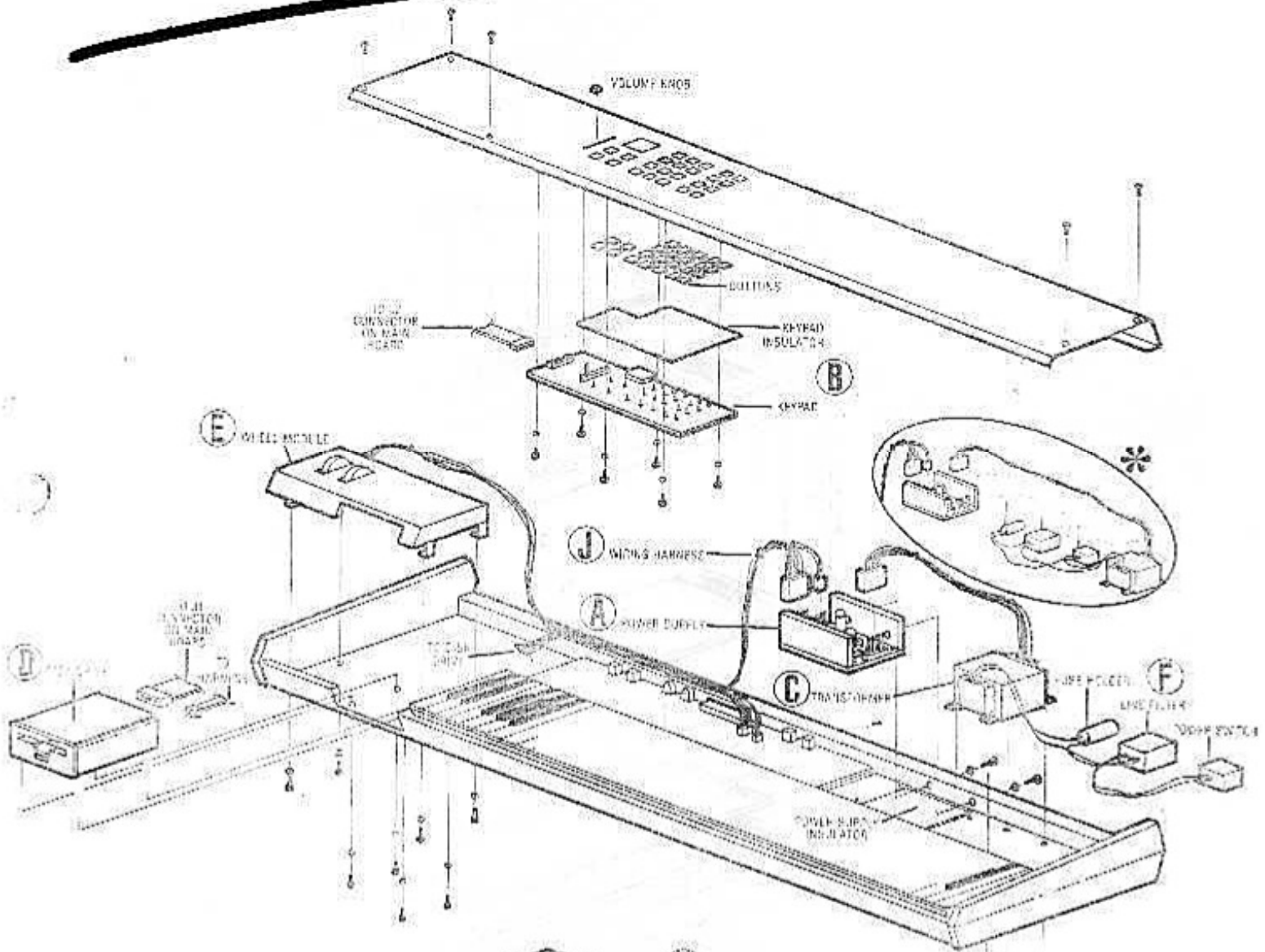

ansonia

Mirage
DIGITAL SAMPLING KEYBOARD

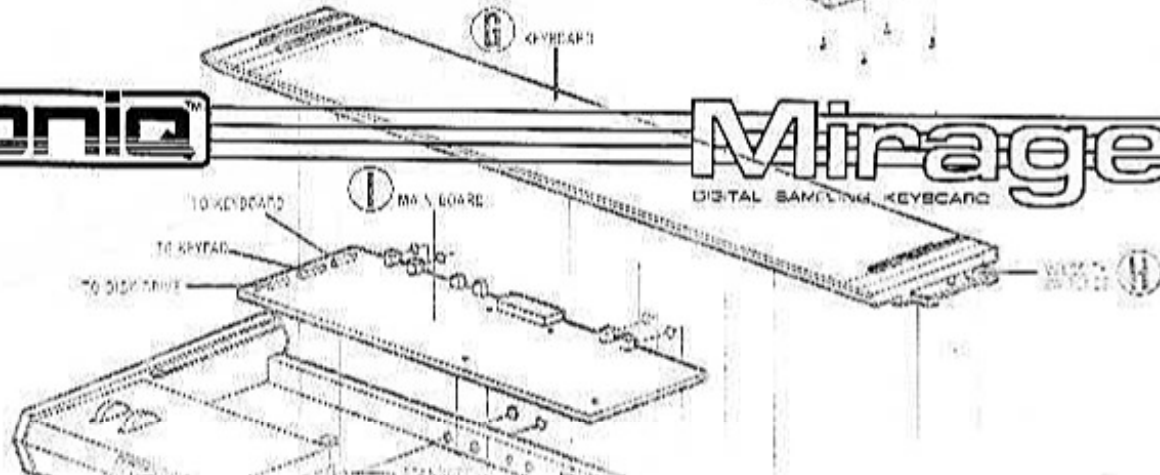

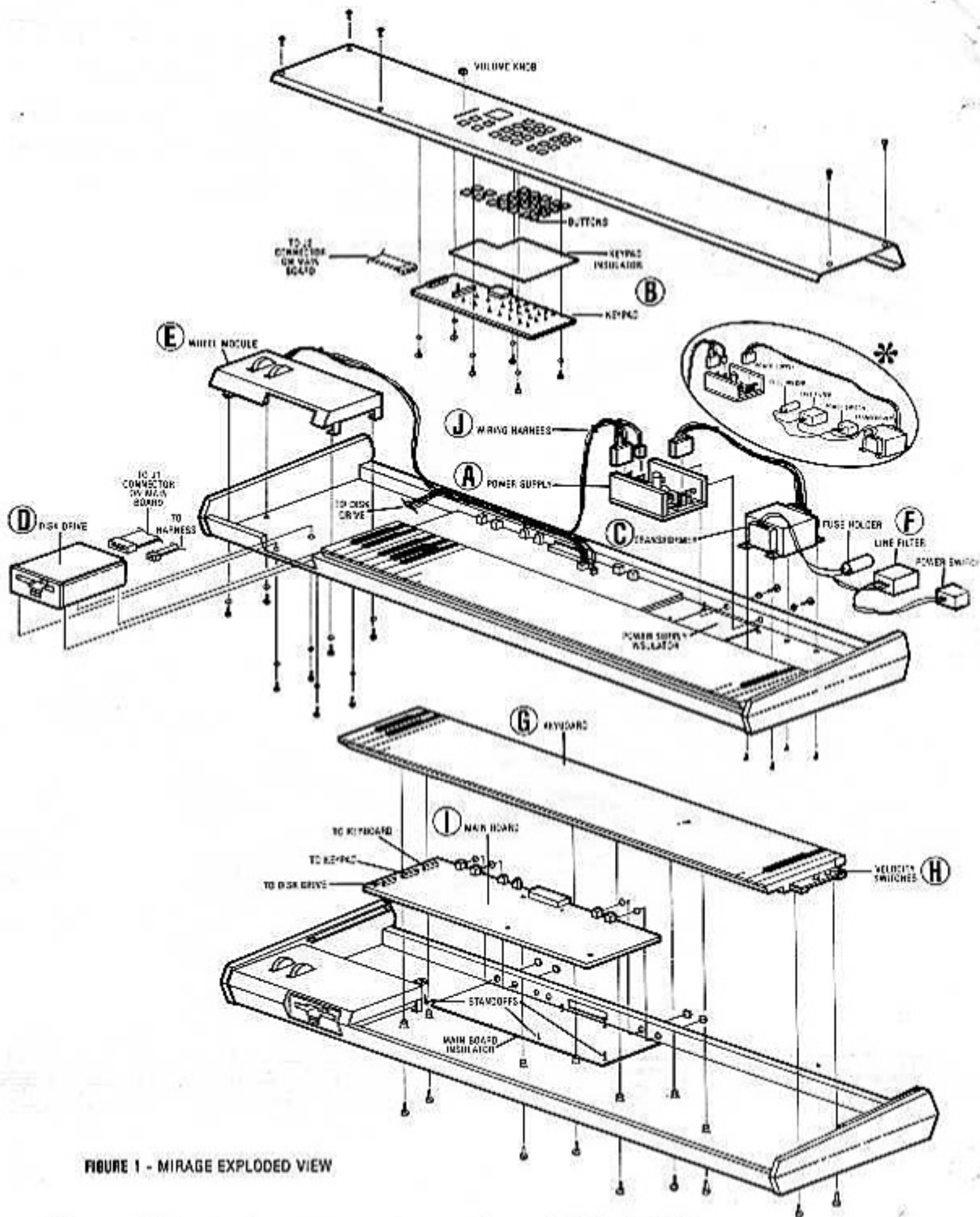

FIGURE 1 - MIRAGE EXPLODED VIEW

*NOTE: The location of some components may vary from early to later production models of the Mirage. However, the replacement procedure will remain the same.

Servicing the Mirage is quite simple and straightforward. Rather than diagnose and replace individual components, you will replace complete modules. The Ensoniq Module Exchange Program is available to all Authorized Repair Stations and will be the most cost and time efficient method for both you and your customer.

At Ensoniq we are equipped with sophisticated machinery to diagnose module faults quickly and accurately. The exchange program will help you to make reliable repairs to your customers' instruments with a minimum of downtime and expense.

The troubleshooting chart will cover just about any occurrence and will tell you which module should be replaced. Refer to the appropriate section for the steps involved in the replacement of the particular module.

TROUBLESHOOTING THE MIRAGE

Most problems with the Mirage will be fairly easy to diagnose, with a few exceptions. What may appear to be disk drive or display problems are often problems with the power supply or with a defective diskette. For this reason, we recommend that you always load a diskette that you know is good and check the power supply before troubleshooting the rest of the unit.

TO CHECK THE POWER SUPPLY

First, plug the Mirage in and turn it on. Then remove the five screws securing the control panel and raise the panel. Check to make sure that all the connections are secure and correct.

When the Mirage has warmed up for five minutes begin to test the voltages at the points shown in Figure 2 and Figure 3A - 3B. If the voltages vary outside the allowable limits, replace the power supply and test the unit before proceeding with further diagnosis.

TRANSFORMER AND POWER SUPPLY VOLTAGE CHECK POINTS

The following charts show the connector terminal number and correct voltage values for the power supply and transformer.

POWER SUPPLY VOLTAGE MEASUREMENTS	
VOLTAGE VALUE	MEASURE BETWEEN TERMINAL NO.'S
+5VDC ±.5% (50mv AC ripple max.)	2 - 4
	3 - 4
	5 - 6
	5 - 7
	6 - 8
+12VDC ±10% (100mv AC ripple max.)	1 - 2
	1 - 3
	8 - 9
-12VDC ±10% (100mv AC ripple max.)	5 - 10
	8 - 10
7.5VAC	11 - 13
	12 - 13
12VAC	14 - 15
	14 - 16
15VAC ±20%	11 - 12
	15 - 16

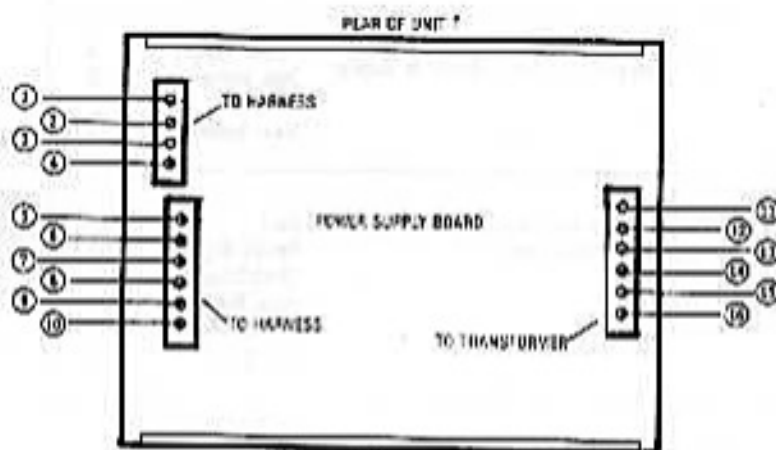

FIGURE 2 - POWER SUPPLY VOLTAGE CHECK POINTS

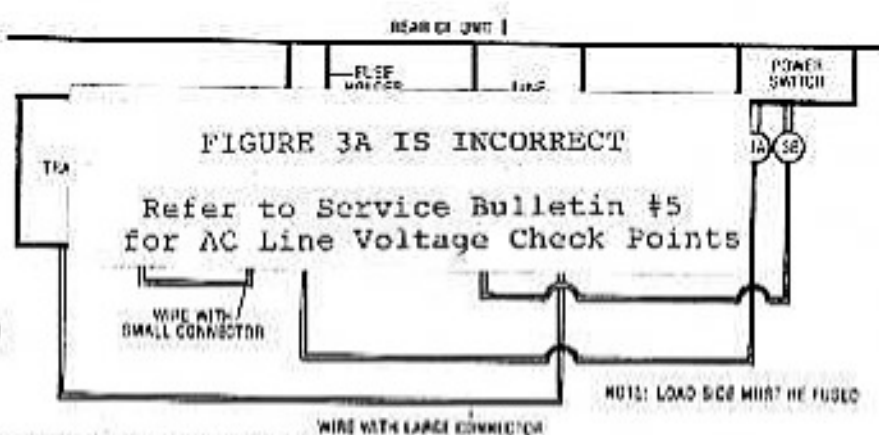

FIGURE 3A - AC LINE VOLTAGE CHECK POINTS WIRING FOR EARLY MODEL CASE (WHERE TRANSFORMER IS ON THE LEFT)

AC LINE VOLTAGE MEASUREMENTS

With the power switch OFF, 120VAC should measure from:

- 1A - 2A
- 2A - 2B
- 3A - 3B

With the power switch ON, 120VAC should measure from:

- 1A - 2B
- 1B - 2B
- 2B - 3A
- 2B - 3B

There should be no voltage across the power switch contacts (3A - 3B).

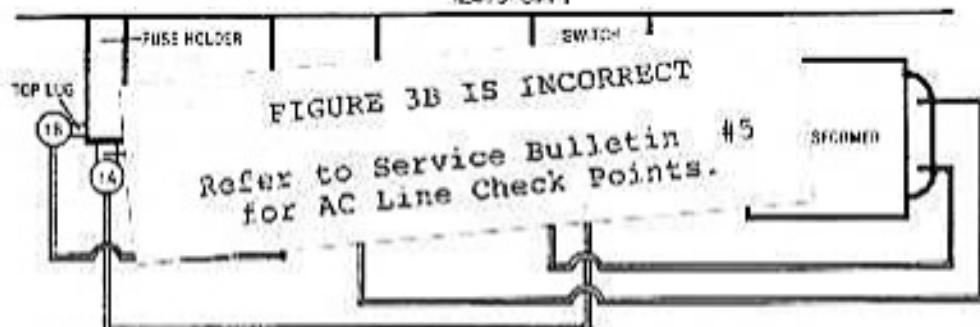

FIGURE 3B—AC LINE VOLTAGE CHECK POINTS
WIRING FOR LATE MODEL CASE (WHERE TRANSFORMER IS ON THE FAR RIGHT)

AC LINE VOLTAGE MEASUREMENTS

With the power switch OFF, 120VAC should measure from:

1A - 2B 2A - 2B 3A - 3B

With the power switch ON, 120VAC should measure from:

1A - 2B 2B - 3A
1B - 2B 2B - 3B

There should be no voltage across the power switch contacts (3A - 3B).

MIRAGE TROUBLESHOOTING CHART

PROBLEM	FAULTY MODULE	SECTION	PROBLEM	FAULTY MODULE	SECTION
Incorrect voltage levels	Power Supply Transformer	A C	Dead keys	Keyboard Main Board	G I
Diskettes won't load	Power Supply Disk Drive Diskette Main Board	A D I	Buzzing noise instead of sound	Keyboard Main Board	G I
"ud" (unformatted disk) shows in display	Power Supply Disk Drive Diskette Main Board	A D I	Velocity Sensitivity Problems	Keyboard Velocity Switches	I B
"nd" (no disk) does not show in display when unit is turned on	Fuse Power Supply Transformer Main Board Power Switch Line Filter	A C I F	Bad display segments	Keypad Keypad Cable Main Board	B I
Blows fuses	Power Supply Transformer Line Filter Power Switch Fuse Holder	A C F	Individual button inoperative	Keypad Keypad Cable Main Board	B I
Buzz or hum in audio output	Transformer	C	Volume control inoperative	Keypad	B
"de" (disk error) shown in display	Diskette Disk Drive Main Board	D I	Pitch or mod wheels inoperative	Wheel Module Main Board	E I
Drive light on or off continuously	Power Supply Disk Drive	A D	Non-transformer noise on output—one voice or all voices	Main Board	I
No sound from drive on power up	Disk Drive	D	Footswitch inoperative	Main Board	I
Press one key—more than one note sounds	Keyboard	G	MIDI problems	Main Board	I
			Sampling function inoperative	Main Board	I
			Unit won't recognize disk	Disk Drive Main Board	D I
			Sync Jack inoperative	Main Board	I

SECTION**A****Replacing The Power Supply**

1. Remove all cables connected to the Mirage, including the power cable.
2. Remove the five screws which fasten the Mirage control panel and raise the panel.
3. Disconnect the wiring harness from the power supply. Note that the cables have connector locks.
4. The power supply is held in place with two screws and nylon shoulder washers through the back panel and with four snap-in standoffs through the circuit board. Remove the screws and shoulder washers from the back panel and unsnap the circuit board from the standoffs by pulling straight up.
5. To replace the power supply, first make sure that the insulator pad is in place, then snap the new unit onto the standoffs, making sure that they are fully seated. Fasten the unit with the two screws and shoulder washers through the rear panel, making sure the screws pass through the holes in the heat sink insulator. Carefully re-connect the wiring harness, paying particular attention to the proper alignment of the pins and connectors.
6. Close the control panel and test the unit.

IMPORTANT!**SECTION****B****Control Button or Keypad Replacement**

Keypad and display related problems will require the replacement of the keypad circuit board. Individual buttons may be replaced. When disassembling the keypad, note that the buttons are held in place and separated from the keypad circuit board by an insulation panel.

1. Remove all cables connected to the Mirage, including the power cable.
2. Remove the volume knob and the five screws which fasten the control panel and raise the panel.
3. The individual buttons are held in place only by the keypad circuit board. To prevent them from falling out when the board is removed, open the control panel all the way and tilt the unit back by placing a 3" block under the front edge.
4. Remove the six screws and lockwashers holding the keypad circuit board. Unplug the connector, noting its orientation.
5. To reassemble, first make sure that all the buttons are in place and then cover them with the insulator. Make sure that the display and lens are clean.
6. Connect the cable to the keypad circuit board, making sure that the cable is not twisted or pinched and install the board using the six screws and lockwashers.
7. Close the control panel, replace the volume knob and test the unit.

IMPORTANT!**SECTION****C****Replacing The Transformer**

At the factory, the Mirage transformer is riveted into place. Replacing the transformer will require drilling out the four rivets and installing the replacement transformer with the screws and nuts provided.

1. Unplug all cords from the unit, including the power cord and remove the five screws which fasten the control panel and raise the panel.
2. Disconnect the transformer cables from the power supply, fuse and line filter, noting the polarity.
3. Tilt the unit up on its back to expose the four rivet heads on the bottom of the case.
4. Tape or otherwise support the transformer from the inside to prevent it from dropping when the last rivet is drilled. Using a 3/16" drill, carefully drill the four rivets until the heads fall off.
5. Install the new transformer using the four screws and nuts supplied, making sure to use the lock washers on the inside. Fasten securely.
6. Connect the transformer cables.
7. Close the control panel and test the unit.

IMPORTANT!

SECTION**D****Replacing The Disk Drive**

The disk drive is held in place with four screws through the bottom of the cabinet. To avoid damage to the drive components, always remove the drive unit from front of the panel.

1. Unplug all cords from the unit and remove the five screws which fasten the control panel, and raise the panel.
2. Disconnect the cables from the drive unit, noting the polarity. This is important because in some earlier units the disk drive cables were crimped wrong and the red line is not Pin 1 but Pin 34.
3. Tilt the Mirage up onto its back to expose the four disk drive fastening screws. Remove the screws while supporting the drive unit with your free hand.
4. Carefully guide the disk drive out through the front panel, taking care not to damage the plastic face plate or exposed components. Do not handle the drive unnecessarily. We suggest that you place it immediately in an anti-static bag or appropriate box.
5. To reassemble, carefully guide the new drive in through the front panel, again giving special care to the face plate and exposed components.
6. Tilt the Mirage up on its back while supporting the drive with one hand. Fasten the drive with the four screws and lockwashers.
7. Reconnect the cables. Note that the ribbon cable has pre-formed bends. Refer to Figure 4 to make sure that the cable is properly routed in the case.
8. Close the control panel and test the unit.

IMPORTANT!

FIGURE 4 - DISK DRIVE CABLE

SECTION**E****Replacing The Pitch and Modulation Wheels**

The pitch and modulation wheels are replaced together, along with the pitch and mod wheel panel and wiring harness. Special care should be given to properly aligning the sheet metal with the front of the Mirage cabinet.

1. Unplug all cords from the unit and remove the five screws fastening the control panel. Lift the panel from the front.
2. Tilt the Mirage up on its back to expose the four wheel module screws on the bottom. Remove the screws while supporting the wheel module with your free hand.
3. The wiring harness is hard wired into the wheel module. Unplug the harness from all four connections and cut the two wire ties to release the harness.
4. To reassemble, first install the new wheel module with the four screws, noting that the screw holes in the cabinet are oversized. Carefully align the module so that it fits flush against the end cap and lines up with cabinet on the front. If this module is not aligned properly, it will interfere with the operation of the keyboard or pitch and modulation wheels.
5. Reconnect the wiring harness and install new wire ties.
6. Close the front panel and test the unit.

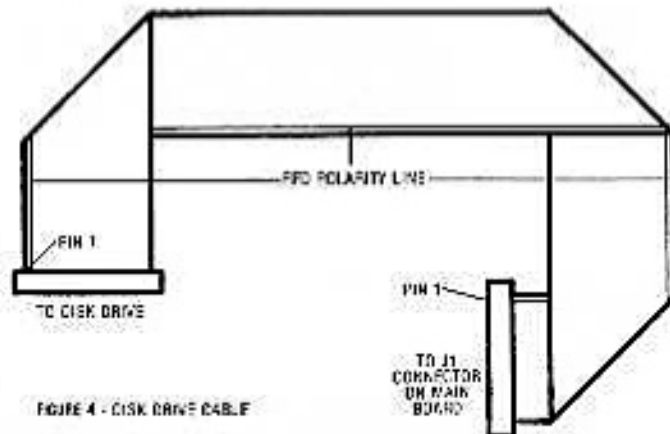
IMPORTANT!**SECTION****F****Replacing The Line Filter**

1. Remove all cables from the Mirage, including the power cable. Check the power cable for continuity.
2. Remove the five screws which fasten the Mirage control panel and raise the panel.
3. Remove the two AC connectors from the filter, noting the polarity.
4. Remove the two screws and nuts which secure the filter to the case. Note that there are lockwashers on both the inside and outside.
5. Install the new line filter from inside the case and reconnect the two AC connectors, noting the polarity. Note on some Mirage units the line filter must be mounted from the outside of the case.
6. Close the control panel and test the unit.

SECTION**G****Replacing The Keyboard**

The Mirage keyboard is mounted in the case using nine mounting screws through the case into two special mounting rails on the underside of the keyboard. Since there are no pre-drilled mounting screw locations in these rails, it is important for you to make sure that the keyboard is aligned properly before final installation. Failure to do so may result in faulty keyboard performance.

1. Remove all cables connected to the Mirage, including the power cable.
2. Remove the five screws which fasten the Mirage control panel and raise the panel.
3. Tilt the Mirage up on its back to expose the nine keyboard mounting screws on the bottom of the unit. Supporting the keyboard with one hand, carefully remove the mounting screws.
4. Slowly lift the keyboard, from the disk drive end, until the keyboard connector on the underside of the keyboard can be seen. Carefully remove the connector, noting that the two blank terminals of the connector face the center of the keyboard.

IMPORTANT!

5. To install the new keyboard, lay the right side of the keyboard into the case and carefully plug the connector into the keyboard. Note that the keyboard cable is pre-formed into several bends. Refer to Figure 5 to make sure the cable is properly routed. Then, lower the left side of the keyboard into the case, making sure that the flat cable is not in danger of being pinched by the keyboard mounting rails.

IMPORTANT!

6. Since the Mirage keyboard uses mounting rails, it is important to align the keyboard properly before installing any of the mounting screws. The keyboard should be positioned so that there is equal clearance between the end key and case on both ends of the keyboard. It may be helpful to use thin cardboard shims to help maintain this clearance during installation.

7. Once the keyboard is aligned, tilt the Mirage up on its back, while supporting the keyboard with one hand. Insert the first mounting screw in the center-front mounting hole, and visually locate the screw into the mounting rail channel. Fasten the screw but do not secure it.

IMPORTANT!

8. Recheck the alignment, and install the remaining mounting screws, occasionally rechecking the keyboard alignment. Remove any shims. To avoid placing any warping stresses on the keyboard or case, tighten the screws from the center of the keyboard outwards.

9. Test the operation of the keys, particularly the end keys. Close the panel and test the unit.

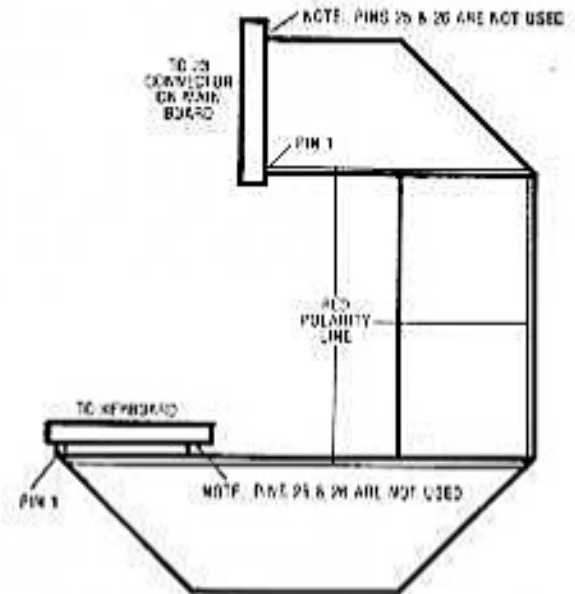

FIGURE 5 - KEYBOARD CABLE

SECTION**H****Replacing Individual Keys & Cleaning The Velocity Switches**

Problems with velocity sensitivity are usually caused by dirt in the velocity sensitivity switching circuit. The circuit and switchpads are located underneath the keys and you will have to remove the keys individually to perform the service.

The flexible switchpads are installed in five sections. The first four sections contain 24 pads (12 keys), while the section on the far right end of the keyboard contains 26 pads (13 keys). In order to properly clean the switchpads, an entire section must be removed. White keys must be removed before black keys can be removed.

1. Remove all cables connected to the Mirage, including the power cable.
2. Remove the five screws which fasten the Mirage control panel and raise the panel.
3. To remove an individual key, pull forward on the key spring and lift the back of the key straight up. Then pull the key forward and out. You will now see two of the gray rubber switchpads under the key.
4. Repeat this procedure until an entire switchpad segment is exposed. Remove the segment by popping it off the circuit board.
5. Clean the switchpad segment and circuit board thoroughly with an electrical contact cleaner (isopropyl alcohol is safe).
6. Pop the switchpad into the circuit board. Install the keys by sliding each key into place, making sure it fits onto the locating peg. Place the rear of the key over the spring. Pull the key slightly forward while pressing down at the rear. The spring should be locked in place at the rear of the key.
7. After all keys are replaced, close the front panel and test the unit.

SECTION**I****Replacing The Main Circuit Board**

When replacing the main circuit board of the Mirage, keep in mind that it is the most expensive module in the unit and is quite fragile and static sensitive. The circuit board is held in place by the audio in and out, footswitch and sync jacks in the rear panel and by three snap-in standoffs in the front of the board.

1. Follow the instructions for the removal of the keyboard (SECTION G - 1 ... 4), with one exception. Instead of removing the keyboard cable from the keyboard, disconnect the J-3 connector from the main circuit board.
2. With the keyboard removed, disconnect the disk drive cable, keypad cable and two harness connectors from the main circuit board.
3. Unfasten the four nuts from the audio in and out, footswitch and sync jacks.
4. Pop the circuit board off the three standoffs on the front of the board. Lift the front of the board and remove it from the unit. Note that there are lockwashers between the jacks and the rear panel and that the two standoffs on either side of the expansion port connector are not secured to the case. Remove these standoffs from the board and save them to install the new board but DO NOT remove the release film from the adhesive pad.
5. Before installing the new circuit board make sure that the board insulator is in place on the bottom of the case, insert the non-adhesive standoffs on either side of the expansion port connector and place the lockwashers on the jacks.
6. With the circuit board tilted slightly to the rear, insert the jacks into the holes in the rear panel and snap the board onto the three front standoffs. Secure the jacks with nuts.
7. Carefully reconnect the disk drive, keypad and harness cables.
8. Install the keyboard according to the instructions in SECTION G - 5 ... 9, with this exception. Since the cable should already be attached to the keyboard, make sure that it is not pinched by the mounting rails and connect it to location J-3 on the main circuit board. Take care that the two unused terminals of the cable connector face the rear of the unit.
9. Close the control panel and test the unit.

IMPORTANT!**SECTION****J****Replacing The Wiring Harness**

1. Remove all cables connected to the Mirage, including the power cable.
2. Remove the five screws which fasten the Mirage control panel and raise the panel.
3. The wiring harness is hard wired into the wheel module. Unplug the harness from all four connections and cut the two wire ties to release the harness.
4. Tilt the Mirage up on its back to expose the four wheel module screws on the bottom. Remove the screws while supporting the wheel module with your free hand.
5. Unsolder the connections at the wheel module and note the location.
6. Solder the new harness to the wheel module. Refer to Figure 6 for the proper configuration. Reconnect the harness and install new wire ties.
7. Follow the instructions for the installation of the wheel module (SECTION E - 4).
8. Close the control panel and test the unit.

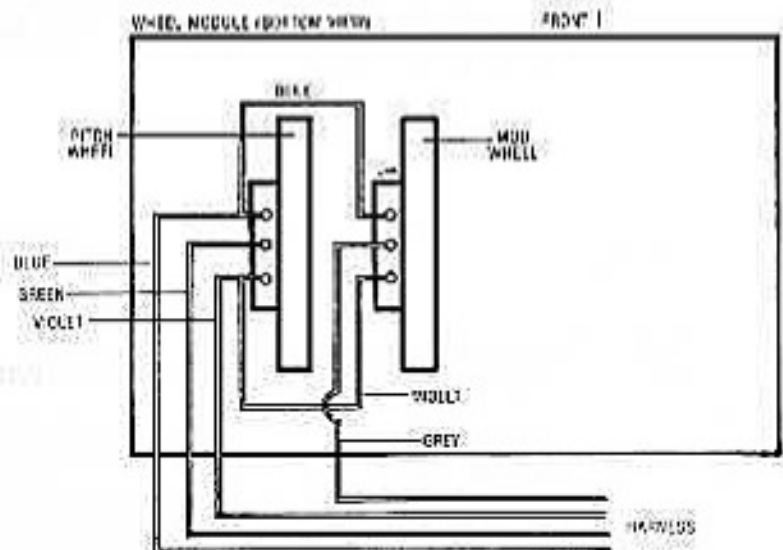

FIGURE 6 - WHEEL MODULE CONNECTIONS

ensonia