

# Service Manual

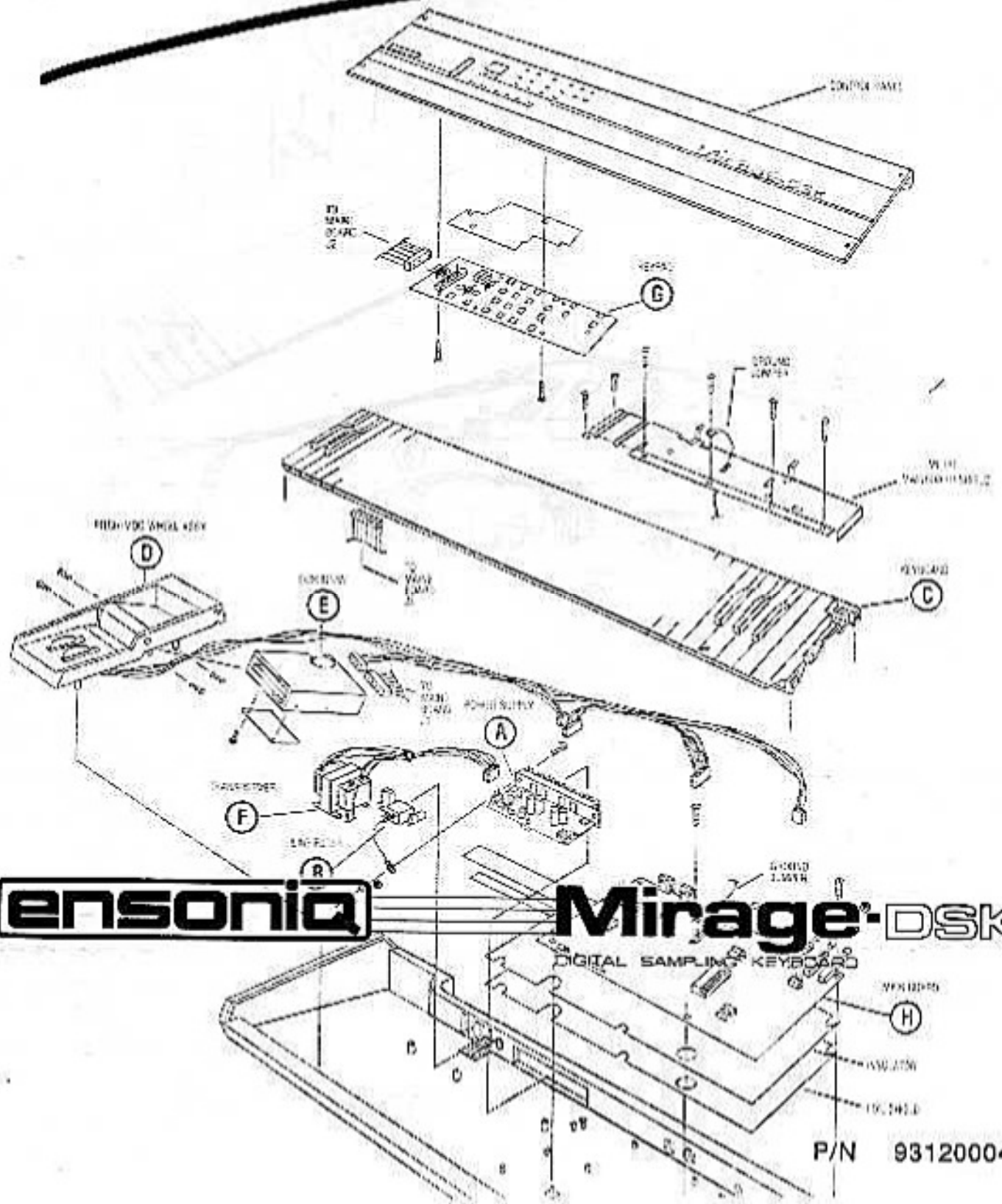

P/N 9312000401

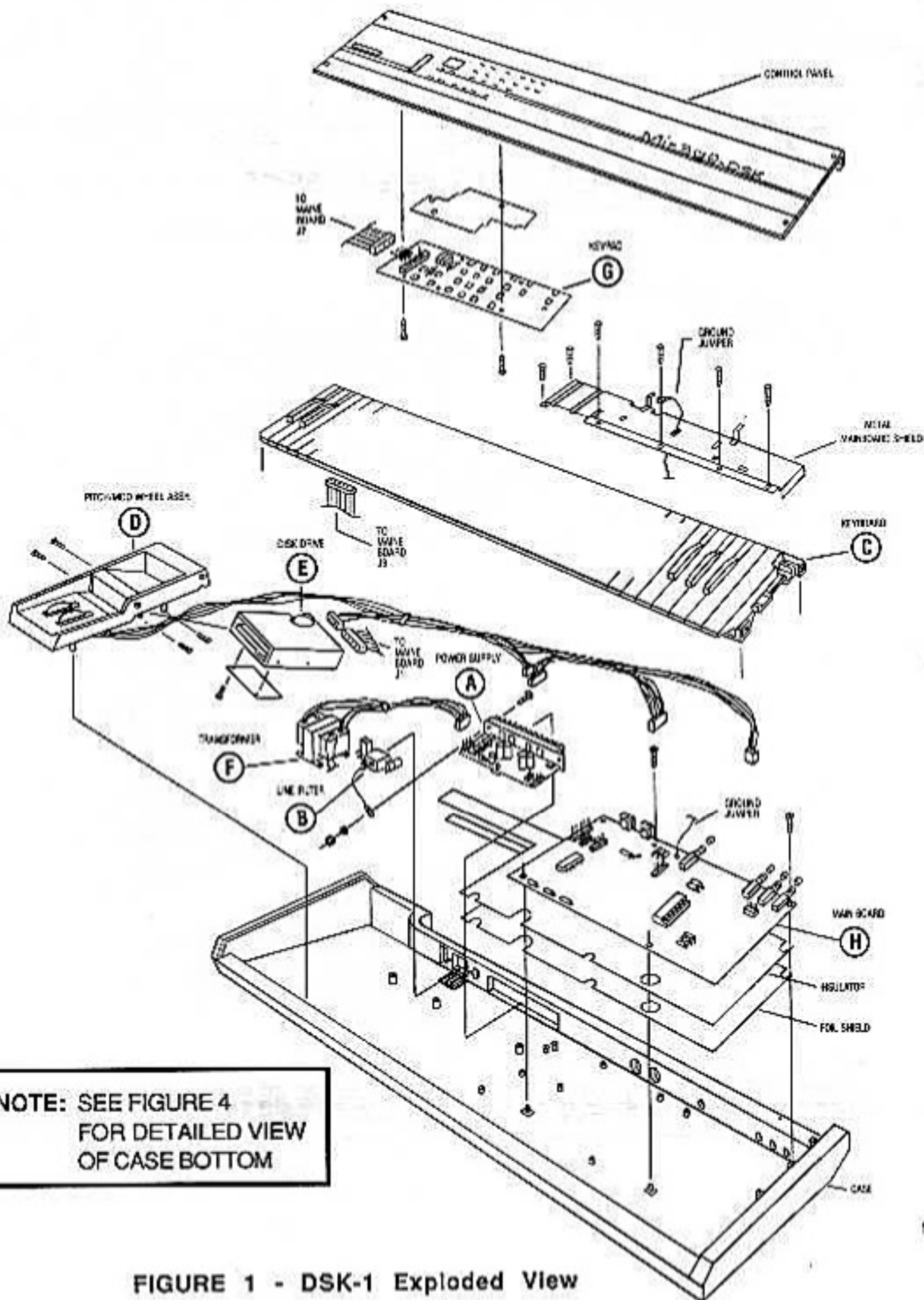

FIGURE 1 - DSK-1 Exploded View

As with every ENSONIQ product, all DSK-1 service will be handled through the Ensoniq Module Exchange Program. Rather than diagnose and exchange individual components, you will replace complete modules. We feel that this is the most time and cost effective method of repair, both for you and your customers.

---

## IMPORTANT: CARING FOR THE PLASTIC CASE

Because the structural components (base, control panel, wheel cover, and keyboard support rails) are made of plastic, *great care* should be exercised when assembling or disassembling any part of the DSK-1.

### AVOID OVERTIGHTENING SCREWS IN THE PLASTIC CASE WHEN EXECUTING ANY REPAIR PROCEDURE!

When replacing any of the self tapping screws it is possible to overtighten and strip the hole in the plastic case. To avoid this (and thereby avoid having to replace the case or control panel):

- Before replacing the screw (or screws) put a drop or two of Super Glue Gel or LOCKITE Quick Gel into the hole.
- Install the screw, tightening only until the subassembly being attached is snug against the plastic case. Do not tighten any further. When the glue sets, the screws will hold the subassembly tightly in place.

---

## THE BOOT-UP PROCESS

When troubleshooting the DSK-1 it is helpful to understand the correct sequence of events required to bring the unit up to it's normal operating condition.

1. Power On. If there is no diskette in the disk drive, the display will begin to flash and which means "no diskette".
2. Insert Diskette. When the diskette is fully inserted into the drive it will snap into place. The disk drive motor will begin to spin the diskette, and the display will go out.
3. Loading the Operating System. Immediately after the display goes out the disk drive begins to read the operating system into internal memory. A series of clicks can be heard from the disk drive during this time (about 3 seconds).
4. Tuning the Filters. Once the operating system is fully loaded into memory the disk drive light will go off. The operating system software will now begin to tune the eight analog filters. This will take from 2 to 4 seconds to complete if successful. If a filter will not tune correctly, the operating system software will continue to try for approximately 15 seconds before moving on to the next filter. The end of the filter tune routine is signaled by a brief flash of .21 on the display.
5. Loading the First Sound Track. Once the tuning routine is completed, successful or not, the operating system software will begin to load the first upper and lower sounds from the diskette. During this time, about 8 seconds, the drive will resume making the clicking sounds until all the sound information is loaded into internal memory. After the disk drive light goes off, the motor will continue to spin for approximately 6 seconds.
6. Normal Operating State. On successful completion of the sound loading operation, the display will show .21, which indicates that the boot up process has ended and normal operation has begun.

**NOTE:** The DSK-1 can and will boot up properly if the unit is powered on when a diskette is already in the drive. However, this is not recommended as transients during power-up could damage the data on the diskette.

## BURN-IN TEST PROGRAM

The Program contained on the burn-in diskette can be used both for diagnostic purposes and for post-repair burn-in. This is the same program used at the factory to burn in all units for 24 hours. The burn-in program tests the DSK-1's MIDI In and Out, Disk Drive, Foot Switch and the Filters.

With the power OFF:

- Connect a MIDI cable between MIDI In and the MIDI Out of the unit.
- Connect 1/4" cable between the Left/Mono Audio Out and the Foot Switch jack.
- Set volume slider to maximum.
- Make sure the burn-in diskette is NOT write protected (tab should be closed).

Turn power ON. Make sure the display flashes and before inserting the burn-in diskette. After loading, the tests should start immediately. You will see displayed, in succession:

Display	Test in Progress
0	Foot Switch test
1	MIDI test
2	Filter Tuning test
3	Disk Drive test
48	Playing Sequence

The sequence will continue to play until the tests begin again. The tests will run approximately every eight minutes. The entire burn-in routine should be run for at least two hours, or longer if possible.

DO NOT remove any cables or remove the burn-in diskette until you have checked the failure counters. Any errors you see might be due to bad cables, connections, or diskette.

#### CHECK FAILURE COUNTERS:

Failure counters must be checked before the units are powered down. While the sequence is playing (48 showing on the display), set parameter 96 to oF to inhibit further tests.

Check value of Parameter 94 first for failures (press 94 then press VALUE). If the value is oF, then all tests have passed. If Parameter 94 is on, one or more of the tests has failed. To determine which one, check the values of the following parameters:

Parameter 90 is the foot switch error counter. Any reading other than 0.0 indicates an error.

Parameter 93 is the MIDI error counter. Any reading other than 0.0 indicates an error.

Parameter 95 is the disk drive error counter. Any reading other than 0.0 indicates an error.

Parameter 39 is the filter-tune error indicator. If it reads oF, then all the filters have successfully tuned.

If Parameter 39 reads on, then one or more filters has failed to tune.

#### IF AN ERROR IS LOGGED:

Test Name	Parameter	Check:
Foot Switch	90	<ul style="list-style-type: none"><li>- volume slider should be at maximum</li><li>- 1/4" cable should be plugged in all the way</li><li>- cable should be plugged into Audio Out Left/Mono (not Audio In)</li><li>- cable continuity</li><li>- If all the above are OK, then a main board problem is indicated</li></ul>
MIDI	93	<ul style="list-style-type: none"><li>- cable should be plugged in all the way</li><li>- cable continuity</li><li>- If all the above are OK, then a main board problem is indicated</li></ul>
Disk Drive	95	<ul style="list-style-type: none"><li>- diskette should not be write protected, window should be closed</li><li>- Burn-in diskette could be defective. See if you can load all three sounds from the burn-in diskette (using the normal Load procedure). If all three sounds are loaded successfully, then the burn-in diskette is OK.</li><li>- If all the above are OK, then the problem is either the main board or the disk drive</li></ul>
Filter Tuning	39	<ul style="list-style-type: none"><li>- if display is blank for a while, unit may be trying to tune a bad filter. Wait 5 minutes to see if display returns. If display doesn't return, the burn-in diskette may be bad.</li><li>- If the burn-in diskette is OK, then a main board problem is indicated</li></ul>

If a cable or the burn-in diskette is found to be bad, replace the defective part and then run the burn-in test for at least 2 more hours to verify that there are no other problems.

To resume the test routine, set parameter 96 to on. The sequence will begin playing, however, the Display will continue to read on until the test routine begins again or until you press PLAY.

To exit the burn-in routine; remove the burn-in diskette and switch the unit off only while the sequence is playing (48 showing on the display).

## TROUBLE SHOOTING THE DSK-1

Most problems with the DSK-1 will be fairly easy to diagnose, with a few exceptions. What may appear to be disk drive or display problems are often problems with the power supply or with a defective diskette. For this reason, we recommend that you always load with a diskette that you know is good and check the power supply *before* troubleshooting the rest of the unit.

TROUBLESHOOTING GUIDE			
SYMPTOM	Possible cause (in order of likelihood)	SYMPTOM	Possible cause (in order of likelihood)
Incorrect voltage levels	Power Supply Transformer	Blows fuses	Power Supply Transformer Line Filter Power Switch Fuse Holder
"nd" (no disk) does not show on display when unit is turned on	Fuse Keypad Cable Keypad Board Power Supply Main Board Transformer Power Switch Line Filter	Footswitch inoperative	Main Board
		MIDI problems	Main Board
		Sampling inoperative	Main Board
"nd" (no disk) shows on display with disk inserted	Disk Drive Cables Disk Drive	Bad display segments	Keypad Cable Keypad Board Main Board
"ud" (unformatted disk) shows on display	Diskette Power Supply Disk Drive Main Board	Group of buttons inoperative	Keypad Cable Keypad Board Main Board
		Individual button inoperative	Keypad Board
"dE" (disk error) shows on display	Diskette Disk Drive Main Board	One key not functioning correctly	Keyboard
continuous hum except while the disk drive is running	Add ground jumper: See following page	Will play sequences but not from keyboard	Main Board Keyboard Keyboard Cable
Fails to tune the filters in the correct amount of time	Main Board Power Supply	A group of eight keys or every eighth key not functioning correctly	Main Board Keyboard Keyboard Cable
One or more voices out	Main Board Power Supply	No audio but display OK	Keypad Board Main Board Keypad Cable Power Supply
Buzzing noise instead of sound	Keyboard Main Board		

## ADDING A JUMPER TO GET RID OF THE 60 CYCLE HUM

(Board Assembly Number 4090005901 Only)

When using an ungrounded power source, a continuous hum may appear that only seems to go away while the disk drive is running. The addition of this jumper will get rid of this hum. However, after this jumper is added, it is recommended that the unit and the amplifier be run off the same power source. (If they aren't, the hum could come back due to a ground loop.)

1. Remove all cables connected to the DSK-1, including the power cable.
2. Remove the four (4) screws that secure the control panel, and raise the panel.
3. Remove the six (6) screws that fasten the metal main board shield to the case and keyboard frame.
4. Disconnect the keypad ribbon cable (J2), the power cable (J6), and the pitch/mod wheel cable (J8) from the main board. Remove the metal main board shield from the unit.
5. Solder the wire end of the provided cable onto the ground square located directly above the power connector (J6), at the center of the main board.
6. While replacing the metal shield, feed the spade lug end of the wire thru the left side of the hole in the shield for the power connector (J6). Install the spade lug to the screw directly across from the J6 opening on the metal shield. Replace the remaining five screws that hold down the metal shield.
7. Power up, test the unit, and close the control panel.

## CHECKING THE LINE VOLTAGE

Check the main fuse at the rear of the unit to make sure it is not blown. **IMPORTANT:** To reduce the risk of fire, replace the main fuse only with the same type: 1.0 Amp, 250 V. Remove the four screws securing the control panel and raise the panel. Check to make sure that all the connections are secure and correct. Plug the DSK-1 into a properly grounded receptacle and turn it on. Using the AC Line Voltage Measurement Chart, measure the AC Voltage at the check points shown in Figure 2. It is normal for Line Voltage to vary +/- 10%.

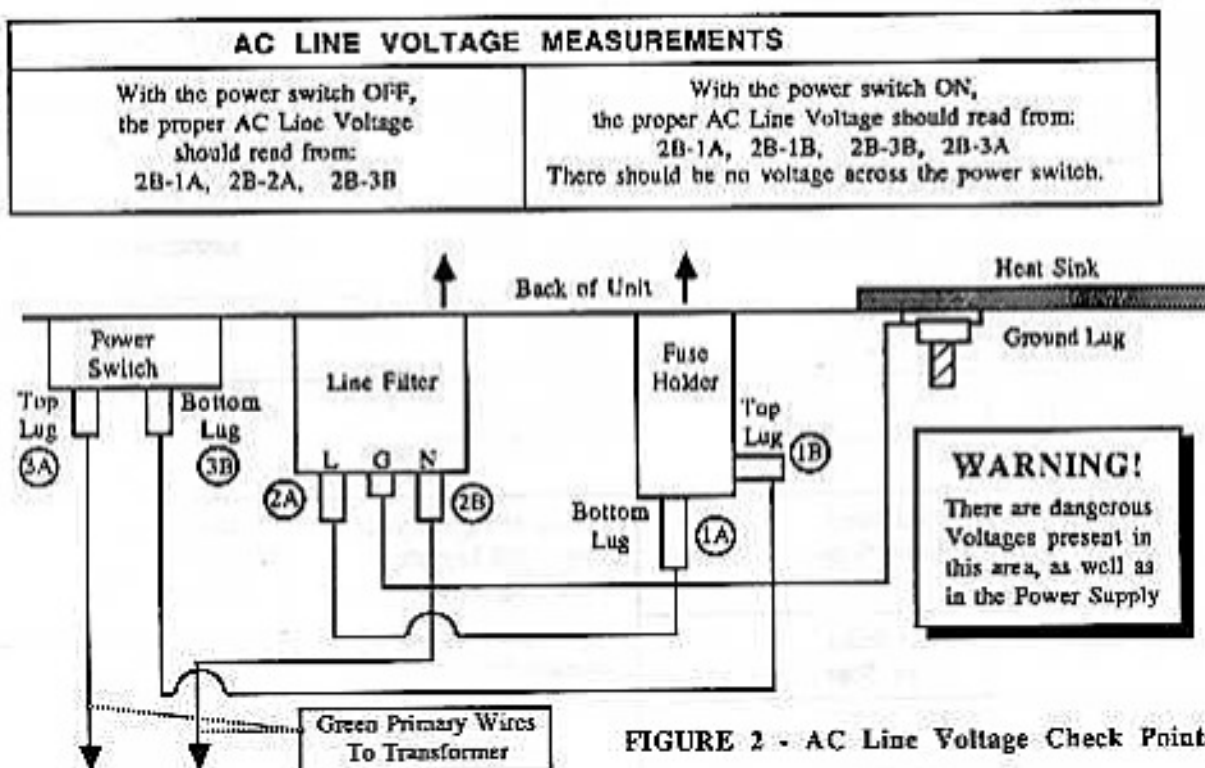
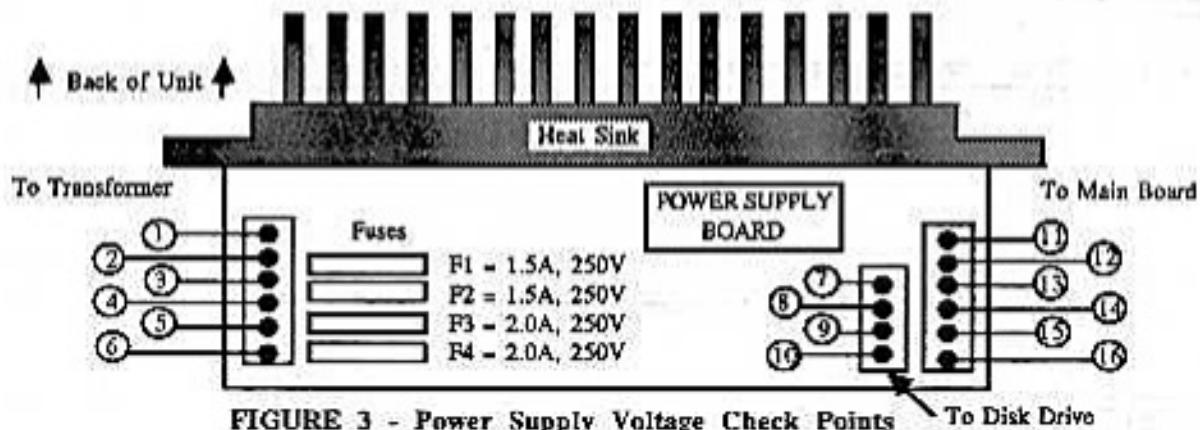

FIGURE 2 - AC Line Voltage Check Points

## POWER SUPPLY MEASUREMENTS

When the DSK-1 has warmed up for five minutes, begin to test the voltages at the points shown in Figure 3. If the voltages vary outside the allowable limits, replace the power supply and test the unit before troubleshooting the unit further. The chart below lists the voltage ranges for proper operation of the Power Supply (fully loaded).



Designation	Terminals		Allowable Range	Units
Analog Supply	1	2	21.6 to 26.4	VACrms
Digital Supply	5	6	12.6 to 15.4	VACrms
+5 Disk Drive	7	8	+4.8 to +5.25	VDC
+12 Disk Drive	10	9	+11.7 to +12.6	VDC
-8 Analog	11	13	-7.6 to -8.4	VDC
+12 Analog	12	13	+11.7 to +12.6	VDC
+5 Memory	14	16	+4.8 to +5.25	VDC
+5 Digital	15	16	+4.8 to +5.25	VDC

### SECTION

## A

## Replacing the Power Supply

1. Remove all cables connected to the DSK-1, including the power cable.
  2. Remove the four (4) screws that secure the control panel, and raise the panel.
  3. Disconnect the two six-pin connectors (J2 and J3), and the four-pin connector (J1) from the Power Supply Board. Note that these connectors are keyed.
  4. Remove the two (2) screws and nuts that secure the Power Supply to the case. Note that there are lock washers on each screw and a ground wire from the line filter on the left screw.
  5. Remove the Power Supply Board by pulling the front of the board toward the keyboard then lifting up so that the heat sink clears the case.
- IMPORTANT!**
6. When replacing with a new board, first make sure that the insulator pad is in place. The standoff is only there for support and should not be stuck down to the case.
  7. Put the replacement Power Supply Board in, heat sink first, from the inside of case. From the outside of the case, lift the heat sink so that it is centered in the opening.
  8. Re-install the Power Supply screws and lockwashers and make sure to connect the ground wire from the line filter. Carefully reconnect the three cables (J1, J2, and J3), paying particular attention to the alignment of pins and connectors.
  9. Power up, test the unit, and close the control panel.

**SECTION****B****Replacing the Line Filter**

1. Remove all cables connected to the DSK-1, including the power cable.
2. Remove the four (4) screws that fasten the control panel, and raise the panel.
3. Remove the three (3) wire tabs connected to the back of the Filter, paying particular attention to polarity.
4. Remove the two (2) screws and nuts that secure the Filter to the case. Note that there are lock washers only on the inside.
5. To replace the Line Filter, first make sure the foil shield is in place. Install the new Line Filter from the outside of the case. The foil shield should make contact against the bottom of the new Line Filter.
6. Reconnect the three wires to the Filter, again noting the proper polarity. Failure to correct the wires to their proper posts can lead to a potential shock hazard, see Figure 2.
7. Power up, test the unit, and close the control panel.

**SECTION****C****Replacing the Keyboard**

1. Remove all cables connected to the DSK-1, including the power cable.
2. Remove the four (4) screws that secure the control panel, and raise the panel.
3. Remove the six (6) screws that fasten the metal main board shield to the case and keyboard frame. Disconnect the keypad ribbon cable (J2), the power cable (J6), and the pitch/mod wheel cable (J8) from the main board. Remove the metal shield from the unit.  
Notice that on later units, a ground jumper is connected from the main board to the metal shield.
4. Place the unit upside down on a soft surface and remove the ten (10) screws that attach the keyboard to the case. See Figure 4 for location of screws.
5. Carefully turn the unit right side up. Raise the control panel and disconnect the keyboard ribbon cable (J3) from the main board, paying particular attention to the polarity.
6. Remove the keyboard from the case by gently lifting the front of the keyboard while pulling it toward the front of the unit. Once the rear of the keyboard has cleared the control panel mounting tabs the keyboard can be removed from the keyboard cavity.
7. Remove the keyboard ribbon cable from the old keyboard, making note of the proper polarity, and install it on the new keyboard.
8. Connect the keyboard ribbon cable (J3) to the main board. Be sure that the cable lies flat beneath the keyboard and is not pinched under the keyboard frame.
9. Insert the new keyboard into the unit rear first at the front of the keyboard cavity. Gently slide the keyboard toward the rear of the unit, lowering the front of the keyboard as needed to clear the control panel mounting tabs.
10. Turn the unit upside down on a soft surface and replace the ten (10) screws that secure the keyboard to the case.
11. Install the metal shield over the main board and replace the six (6) screws fastening it to the case and keyboard frame. Be sure to attach the ground jumper, if present.
12. Connect the keypad ribbon cable (J2), power cable (J6), and pitch/mod wheel cable (J8) to the main board.
13. Power up, test the unit, and close the control panel.



**SECTION****D****Replacing the Pitch/Mod Wheel Assembly**

The Pitch and Mod Wheels are replaced as an assembly along with the cable harness. The disk drive is also mounted in the same assembly.

1. Remove all cables connected to the DSK-1, including the power cable.
2. Remove the four (4) screws that fasten the control panel, and raise the panel.
3. Place the unit upside down on a soft surface and remove the four (4) screws that attach the wheel assembly to the case. See Figure 4 for location of screws.
4. Return the unit to an upright position. Cut the wire ties that hold the wire harness in place, and disconnect the harness from the main board (J6, J8) and power supply (J1, J2). These connectors are keyed, and have connector locks. Carefully lift the wheel assembly out of the case.
5. Disconnect the two cables from the disk drive, paying particular attention to polarity.
7. Remove the four (4) screws and lock washers that attach the Disk Drive to the wheel assembly.
8. Slide the Disk Drive out of the wheel assembly. Slide the disk drive into the new wheel assembly and mount it using the four screws and lock washers. Reconnect the two Disk Drive cables, paying particular attention to the alignment of pins and connectors.
9. Connect the new wire harness to the main board (J6, J8) and power supply (J1, J2), paying particular attention to the alignment of pins and connectors. Reconnect the wire harness to the case using wire ties.
10. Re-attach the wheel assembly to the case using the four screws.
11. Power up, test the unit, and close the control panel.

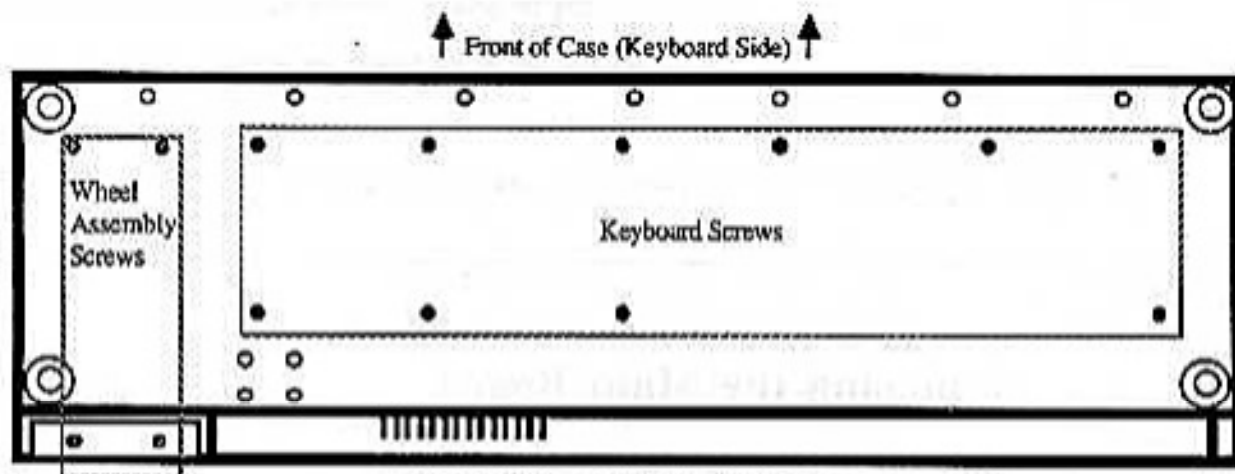
**FIGURE 4 - Bottom of Case****SECTION****E****Replacing the Disk Drive**

1. Remove all cables connected to the DSK-1, including the power cable.
2. Remove the four (4) screws that fasten the control panel, and raise the panel.
3. Turn the unit over, top down, and remove the four (4) screws that attach the wheel assembly to the case. See Figure 4 for location of screws. Return the unit to an upright position. Carefully lift the wheel assembly out of the case.
4. Disconnect the two cables from the Disk Drive, paying particular attention to polarity.
5. Remove the two (2) screws and lock washers that attach the metal plate to the bottom of the Disk Drive. Remove the four (4) screws and lock washers that attach the Disk Drive to the wheel assembly.
6. Carefully slide the Disk Drive out of the wheel assembly. Place defective drive immediately in an anti-static bag. Slide the new Disk Drive into place and mount using the four screws and lock washers.
7. Attach the metal plate to the new Disk Drive using the two screws and lock washers. Reconnect the two cables, paying particular attention to the alignment of pins and connectors.
8. Re-attach the wheel assembly to the case using the four screws.
9. Power up, test the unit, and close the control panel.

**SECTION****F****Replacing the Transformer**

Due to problems that may occur because of the plastic case, all units that need the Transformer replaced should be sent back to the factory (outside U.S., contact your distributor).

**SECTION****G****Replacing the Keypad Board**

Keypad and display related problems will require the replacement of the Keypad Board. Individual buttons may be replaced. When disassembling the keypad, note that the buttons are held in place and separated from the Keypad Board by an insulator.

**IMPORTANT!**

1. Remove all cables connected to the DSK-1, including the power cable.
2. Remove the volume knob. Remove the four (4) screws that fasten the control panel, and raise the panel.
3. The individual buttons are held in place by the Keypad Board and the insulator. To prevent them from falling out when the board is removed, make sure to open the control panel all the way.
4. Unplug the keypad cable from the keypad, noting the polarity. Remove the six (6) screws holding the Keypad Board in place.
5. To reassemble, first make sure that the insulator and all the buttons are in place. Make sure that the display lens is clean.
6. Install the new board using the six screws, and reconnect the cable making sure that it is not twisted improperly or pinched.
7. Replace the volume knob. Power up, test the unit, and close the control panel.

**SECTION****H****Replacing the Main Board**

1. Remove all cables connected to the DSK-1, including the power cable.
2. Remove the four (4) screws that fasten the control panel, and raise the panel.
3. Remove the keyboard and metal main board shield, see Section C. Note that you should remove the twenty-six pin ribbon cable from the Main Board (at J3) instead of from the keyboard.
4. Disconnect the disk drive ribbon cable (J1) from the main board.
5. Remove the four (4) nuts from the rear panel jacks marked Fl. Sw., Audio In, Left/Mono and Right Audio Out.
6. Remove the three (3) screws along the rear of the main board.
7. Remove the board and the four (4) white standoffs from the case.
8. Before installing the new circuit board and standoffs, make sure the cardboard insulator is in place.
9. Clean the area on the base with alcohol where the new standoffs will go. This will help the new standoffs adhere to the base. Peel off the adhesive covers from the standoffs.
10. With the board tilted on a slight angle, insert the jacks into the holes in the rear panel. Press the board down into place. Make sure the standoffs stick to the base.
11. Replace the main board screws and secure the jacks with the nuts.
12. Connect the disk drive ribbon cable.
13. Re-install the the keyboard and metal shield, see Section C.
14. Power up, test the unit, and close the control panel.