

Contents

Introduction	1
Introduction	3
About EOS	4
Graphic User Interface	4
Sequencer and Data Filer	4
Sound Libraries	4
Sound Storage	4
Advanced DSP	4
Built-in Digital Effects	5
More Digital Processing Features	5
Instant Gratification	6
Power Up!	6
Loading a Bank from the Hard Disk	7
Loading SoundSprints	7
Selecting Presets	8
Lock Button	9
Saving	10
Arpeggiator	11
Keyboard Modes	14
1 - The Basics	17
Definitions	19
How Sounds are Organized	19
The Sample	20
Voices	21
The Preset	22
SoundSprint	23
Preset Diagram	23
Bookmarks	25
The Bank	26
Folders	26
The Internal Drive	27
External Drives	28
Sample Memory & Preset Memory	29
Sound ROM & Sound RAM	29
Five Types of Memory	29
Flash Sound RAM	30
Sample Numbers	31
Using Preset Flash Memory	31
Using Sound Flash Memory	32

Modules	34
More Definitions	36
Saving	36
Default	36
Icons	36
The Cursor	37
Data Entry Control & Increment/Decrement Buttons	37
Selecting	37
The Big Re-Cap	37
Using The Browser	38
Guided Tours	41
Banks, Sequences, Presets & Samples	41
Loading a Bank Automatically	42
Loading a Sequence from a Different Bank	43
Loading Standard MIDI Files	44
Saving Banks	44
Finding Banks, Presets, Samples & Sequences	45
Naming Banks	46
Erasing Banks	46
Assignable Keys	46
Recording a Sequence	47
Arpeggiator Sequencing!	50
A Practice Sampling Session	53
Exploring the Preset	57
Which Voices are Assigned to the Keyboard?	58
Creating a Link	59
2 - Master Menu	61
Overview	63
Memory Statistics	64
Master Utilities	65
Assignable Keys	66
Channel Volume	67
Tones	67
Recalibration	68
Test Access	69
About...	70
Bank	71
Erase Bank	71
Name Bank	72
Auto Bank Load	72
Flash Utilities	73
Using Sound Flash Memory	75

Setup	78
Tune	79
Tuning Offset	79
Transpose	79
Audition Key	80
Input/Output	80
Headroom	80
Output Boost	82
Output Format	82
ADAT Output Dither	83
Default Clock	84
Word Clock In	85
WC Phase In/Out	85
Miscellaneous	86
Contrast	86
Wrap Field Selection	86
Screen Saver	87
Disable Sound ROM	87
Zero Crossing Threshold	88
Undo/Redo Enable	89
SCSI/Disk	90
SCSI ID	90
SCSI Termination On/Off	91
Avoid Host on ID	91
Disk Button Goes To:	92
Import Options	93
Memory Configuration	95
Master Effects	96
Use Master Effects Settings in MultiMode	97
Master Effects A	97
Master Effects B	98
Effects Setup	98
Effects Control	99
Sequence Manage	101
MIDI	102
MIDI Mode	103
Basic Channel	103
MIDI Mode	103
MIDI Device ID	104
Local Control	105
Multimode - MIDI Mix	106
MIDI Controllers	108
About MIDI Controllers	108
MIDI Preferences	110
Velocity Curve	110

Controller #7 Sensitivity	110
Controller #7 Curve	111
Global Pedal Override	111
Receive Program Change On/Off	112
Send Program Change On/Off	112
Magic Load Preset	113
3 - Effects	115
Effects	117
Dual Effects Processor	117
The Effects Sends	118
Effect B Into Effect A	120
Three-way Effects Control	121
Effects Programmed in the Preset	122
Master Effects	122
Using Master Effects Settings in Multimode	123
Using the Effects Channel Settings in Multimode	124
Effects Bypass	125
Effect Descriptions	126
A EFFECT TYPES	126
B EFFECT TYPES	126
Reverb	127
Chorus	128
Doubling	128
Slapback	128
Stereo Flanger	128
Delay	129
Stereo Delay	129
Panning Delay	129
Dual Tap	129
Vibrato	129
Distortion	129
4 - Sequencer	131
Sequence Manage	133
Recording MIDI SysEx	136
Standard MIDI files	136
Name Sequence	137
Export	138
Transport Controls	139
Sequencer Utilities	140
Erase	140
Copy Sequence	141
Sequencer Memory	141
Jukebox	142
Sequence Edit	142

Sequence Edit	143
The Sequence Edit Screen	144
Track Mode	144
Track Numbers	144
Counter Display	144
Tempo Display	144
Track ' Preset	144
MIDI Channel Modes	145
Volume - Pan - Submix	145
The Initial Track State Screen	145
Initial Tempo	146
Cut/Copy	146
Editing: Cut, Copy & Paste	147
Cut/Copy/Erase	147
Note Erase	148
Paste	150
Track Delete	152
Track Copy	152
UNDO! (REDO!)	153
Tools.....	154
Quantize	154
Transpose	156
Sequence Velocity	157
Channelize	158
Channel Extract	159
Setup	160
Metronome	161
Sequence Clock	162
Sequence Input	164
Sequence Record	165
Sequence Loop	166
Transport	167
Received MMC Commands	168
Locate	169
5 - Sample Manage	171
Overview	173
Sample Utilities	174
Erase Sample	174
Copy Sample	175
Sample Dump	175
Defragment Memory	177

Name Sample	178
New Sample	178
Threshold	179
Input Channels	179
Sampling Source & Rate	179
Dither	180
ADC Gain	181
Sample Length	182
Arm Sample Trigger	182
Force Sample Trigger	183
Keyboard Sample Trigger	183
Monitor On/Off	184
Automatic Parameters	184
Automatic Digital Signal Processing Operations	184
Auto-Placement Parameters	186
Place Sample	188
Export Sample	189
Get Info	190
6 - Sample Edit	191
Sample Edit	193
Background: The Scrub Wheel	194
Background: Using Cut, Copy, Paste and Undo	195
Background: About Looping	196
How Looping Works	196
Auto Correlation	196
Creating Attack & Decay Characteristics for the Looped Portion ..	197
Loop Compression	198
Crossfade Looping	198
Zero Crossing	198
Utilities	199
Cut Section	199
Copy Section	201
Paste Section	202
Truncation	204
Taper	205
Tools 1	207
Loop	207
Loop Type	210
Digital Tuning	211
Sample Rate Convert	212
Sample Calculator	213

Tools 2	214
DC Filter	214
Swap Left & Right	215
Stereo <-> Mono	216
Reverse Section	216
Sample Integrity	217
Tools 3	218
Gain Change	218
Compressor	221
Using the Digital Compressor	224
Limiter	224
Musical Compression (e.g. Guitar)	224
Noise Reduction	224
Parametric Equalizer	225
FIR (Phase Linear Filter)	227
Aphex Aural Exciter	229
Tools 4	230
Transform Multiplication	231
Doppler	232
Time Compression	234
Pitch Change	235
Bit Converter	236
Beat Munger	237
Beat Munger Controls	238
Undo	240
7 - Preset Manage	243
Preset Manage	245
Utilities	246
Erase Preset	246
Dump Preset	246
Name Preset	247
New Preset	247
Copy Preset	248
Export Preset	249
Get Info	250

8 - Preset Edit	251
Synthesizer Basics	253
Editing Presets	253
Modulation	254
Modulation Sources	255
Modulation Cords	256
Envelope Generators	257
Low Frequency Oscillators (LFOs)	258
Random Sources	259
Clock Modulation	260
Modulation Destinations	262
Modulation Processors	263
Modulation Processors	264
Dynamic Filters	269
Dynamic Filters	269
What is a Filter?	270
Parametric Filters	273
The Z-Plane Filter	273
Selecting Voices, Samples & Groups	275
Selecting from the Preset Editor Windows	275
Selecting All Voices	276
Selecting Voices from the Dynamic Processing Level	276
Selecting Voices from the Voice Select Screen	276
Groups	277
Preset Editor	278
PRESET EDIT - Global	281
Global Editor	281
Edit All	281
Preset Effects A	282
Effects Programmed in the Preset	283
Effect	284
Decay Time	285
HF Damping	285
FX Amounts	285
FX B Through FX A	286
Preset Effects B	287
Effect B	287
Feedback Amount	288
LFO Rate	289
Delay Time	289
FX Amounts	290
Preset Edit - Links	291

Main Controls	291
Link Type	292
Link Volume	292
Link Pan	293
Link Transpose	293
Link Fine Tuning	294
Link Utilities	295
New Link	295
Copy Link	296
Delete Link	296
Subsume Link	297
Links - Key Window.....	298
Key Window Controls	298
Keyboard & Velocity Ranges	299
Links - Velocity Window	300
Velocity Window Controls	300
Velocity Range	301
Links - MIDI Filters	302
MIDI Filter Window Controls	302
Preset Edit - Voices	304
Voices - Main Controls	304
Voice Utilities	305
New Voice	305
Copy Voice	305
Delete Voice	306
Split Voice	306
Solo Voice	307
Sample Zone	308
New Sample Zone	308
Get Multisample	309
Delete Sample Zone	309
Combine	310
Expand...	311
Voices - Key Window	312
Key Window Controls	312
Keyboard Ranges	313
Voices -Velocity Window	316
Velocity Window Controls	316
Velocity Range	317

Voices - Realtime Window	319
Realtime Window Controls	319
Preset Edit - Dynamic Processing Level	322
Utilities	325
Voice Select	326
Function Keys	326
The Isolate Key:	328
Copy Voice(s)	328
Delete Voice(s)	330
Automatic Voice Selection	331
Set	331
Solo Voice	331
Voice Tuning, Modifiers & Setup	332
Key Transpose	333
Coarse Tuning	333
Fine Tuning	334
Non-transpose Mode	334
Chorus Amount	335
Delay	336
Start Offset	336
Glide Rate & Curve	337
Solo Modes	338
Latch Mode	339
Assign Group	340
Amplifier/Filter.....	341
Amplifier Parameters	341
Amplifier Envelope	342
Filter Parameters	343
FILTER TYPES	343
Filter Envelope	347
LFO/Auxiliary Envelope.....	348
Lag Processors	349
Auxiliary Envelope	350
Cords	351
Sample Retrigger	353

9 - Disk Menu	355
Disk Menu	357
Disk Browser	357
Disk	361
Disk Utilities	361
Mount Drives	362
Copy System	362
Format Disk	363
Low Level Format	364
Backup	364
Load Bank	366
Save Bank	367
View...	367
Info, Lock Drive, & Sleep	368
Lock	368
Sleep	368
Folder	369
Folder Utilities	369
New	369
Delete	370
Rename	370
Find...	370
View	371
Info...	371
Bank	372
Bank Utilities	372
Delete	372
Name	373
Find...	373
Load Bank	374
Save Bank	374
View	375
Info...	375
Preset	376
Preset Utilities	376
Soundsprint™	376
Bookmarks	378

Find...	379
Load Preset	380
View	380
Info...	380
Sample	381
Sample Utilities	381
Find...	381
View	382
Load Sample	382
Load .WAV & AIFF Files	383
Audition	383
Info...	383
Sequence	384
Sequence Utility	384
Find...	385
View	385
Load Sequence	385
Info...	386
10 - Appendix	387
SCSI	389
Why Use SCSI?	389
The SCSI Bus	389
ID Numbers	389
Types of SCSI Cables	390
Terminating SCSI Cables	390
SCSI Problems	391
Sample Transfers Via SMDI	392
Using Multiple Samplers on the SCSI Bus	393
Menu Maps	394
Menu Maps	394
Menu Maps	395
Menu Maps	396
MIDI	397
MIDI Implementation Chart	397
Notes:	398
Index	399

Introduction

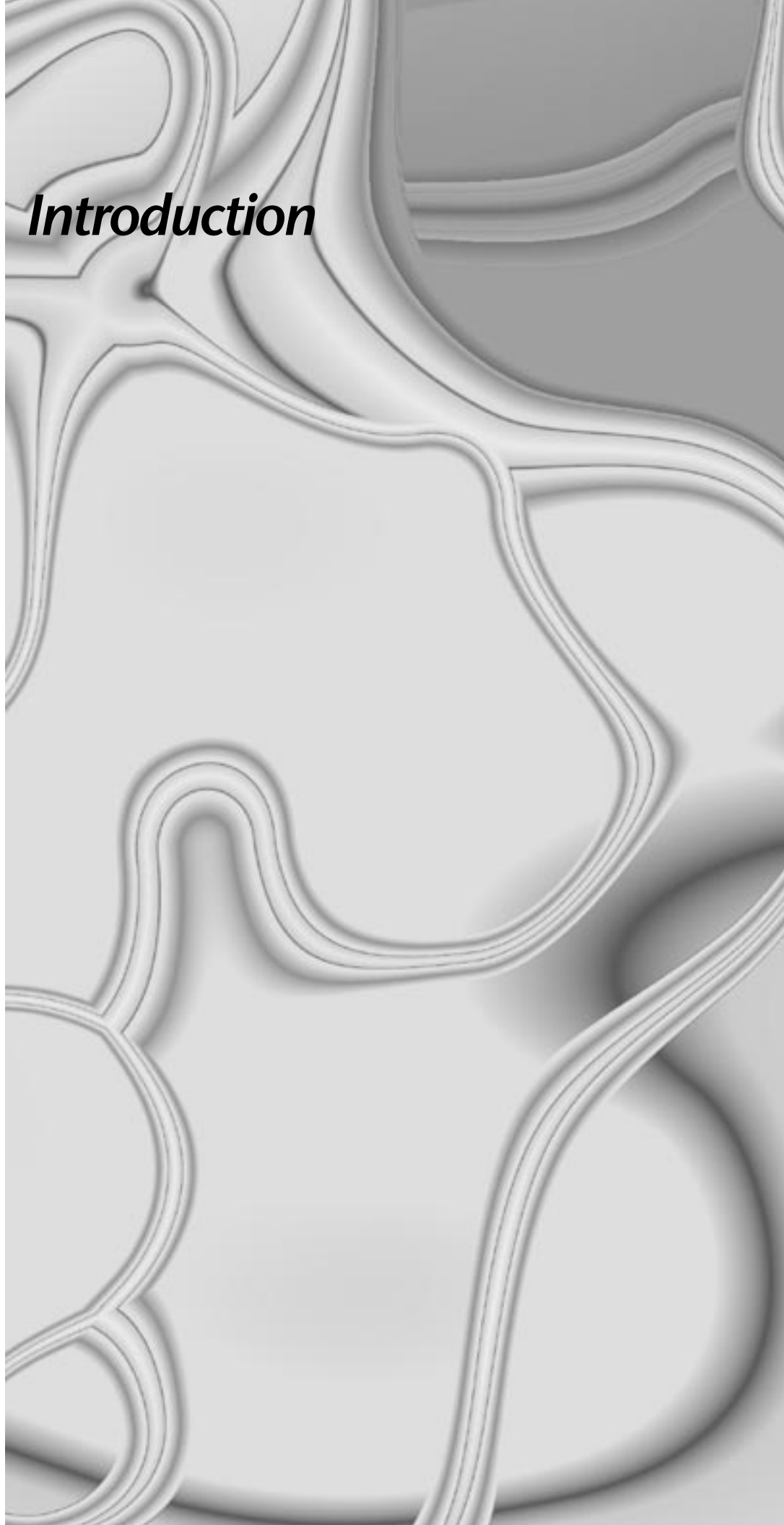

Introduction

Introduction

This is the operation manual for E-mu Operating System (EOS). EOS is the operating system in several E-mu products, including: E-IV, e-64, E4K, E-6400, E4X, E-Synth and the E4 Ultra series. The same EOS software is loaded into each of these machines. For the sake of simplicity, we refer to all these products as “the Emulator” when we talk about them in this manual (unless, of course, there is an issue involving a particular product, then we will be specific).

Your Emulator is a special purpose sound computer and like all computers, can be thought of as having two main components:

1. The physical machine with the buttons, keys, gadgets, that generates sound and;
2. The EOS software that tells the hardware what to do.

This manual describes how to use EOS to get the most from your Emulator. The various functions of EOS are organized in this manual by their module. Screen displays and step-by-step instructions are described for all aspects of use and operation. Notes in the margin highlight important points or give useful operational tips which might not be readily apparent.

If you are unfamiliar with samplers and synthesizers in general, you may need more information than this manual provides. We suggest that you read some of the many books and magazines on the subject of music synthesis. This will help you to get the most out of this extremely powerful instrument.

Important Upgrade Information

The features and functions of EOS are enhanced and upgraded periodically. Please take a moment now to read the E-mu Systems warranty and fill out and send in your warranty registration card. We NEED your mailing address in order to keep you informed about upgrades and manual revisions.

About EOS

Graphic User Interface

EOS uses icons, graphics and dialog boxes extensively to make programming as easy and as intuitive as possible. Similar functions are logically grouped into menus and navigation controls such as the Cursor and Page buttons make it easy to select the desired field.

Sequencer and Data Filer

The onboard 48-track sequencer is a full function music production center. It contains a host of powerful features such as high resolution cut and paste editing, quantization, data filters, and external sync capability. It is also capable of reading and playing back standard MIDI files (format 0 & 1) direct from a DOS floppy disk and saving them to the internal hard disk drive. Music sequences are stored within banks or as separate objects.

Sound Libraries

The Emulator family has access to the huge library of sounds available from E-mu and other sources. EOS is fully compatible with the E-IV, e-64, EIII, EIIIX, ESI-32, E4K, E-6400, E4X, E-Synth and Ultra sound libraries, and can transparently read Emax II, Roland S-700 and Akai S1000/S1100/S3000 banks via SCSI HD or CD-ROM without awkward conversion routines.

Sound Storage

EOS lets you arrange up to 1000 samples per bank in up to 1000 presets. E-mu's exclusive SoundSprint™ function automatically loads presets from the hard disk as you browse through them. You can continue to play while the new preset is loading in the background. The Sound ROM option (standard on E-Synth) gives you 16 MB of great samples with hundreds of user programmable presets which are always on-line and ready to go.

Advanced DSP

EOS's advanced digital signal processing (DSP) features make sampling a breeze. Samples can be truncated, normalized and placed on the keyboard automatically as the sample is taken. Advanced tools such as Auto Correlation, Loop Compression and Crossfade Looping allow even the most difficult sounds to be looped easily.

You can digitally splice and mix samples with other samples. Control samples dynamically from the keyboard using velocity and positional cross-fading and switching functions. Advanced digital processing features such as Sample Rate Conversion, Compression, Parametric Equalization and Digital Tuning let you shape raw samples quickly and with greater precision than computer based systems. Samples are easily transferred between the Emulator and an external computer via SCSI.

Additional digital processing functions include:

- **Time Compression and Expansion:** Shortens or lengthens the sample time without changing the pitch.
- **Pitch Change:** Changes the pitch of a sample without altering the time.
- **Transform Multiplication:** Creates weird and wonderful new timbres.
- **Aphex Aural Exciter:**TM Adds brilliance and sheen to your samples.
- **Dopplerization:** Moves samples forward and backwards in space as well as from side to side.
- **FIR Filters:** Non-realtime digital filters with “Ultra” high Q values and phase-linear filter response.
- **Bit Converter:** Removes unwanted bit resolution from your samples.
- **Beat Munging:** Analyzes drum loops and phrases and allows you to change tempo, time signature, swing and individual beats in real-time.

Built-in Digital Effects

A high quality internal effects processor adds reverb and chorus effects while keeping the sound in the digital domain. 76 different effects are currently implemented with several controllable parameters for each effect. A sound with effects applied can be resampled and saved as an entirely new sound, with ambience and effects included.

More Digital Processing Features

The digital hardware implements up to 128 “analog-sounding” Z-plane filters with many different filter types.

- 12, 24, or 36 dB/octave Low-pass filters with resonance
- 2nd & 4th order High-pass filters with resonance
- 2nd & 4th order Band-pass filters with resonance
- Contrary Band-pass filter
- Three types of swept EQ filters
- Three Phasers and one Flanger with resonance
- Six powerful Morphing filters

Modulation sources include three multi-stage envelope generators and two multi-wave LFOs per channel with full MIDI modulation control over virtually every parameter. The digital patchbay, containing a set of arithmetic modifiers, let you create complex synthesis models.

EOS Emulators have 32 part multi-timbral capability, allowing complex sequencing and sound effects creation. Emulators can be operated by remote control using an external computer. A MIDI expander card is available for older units which increases the number of MIDI channels from 16 to 32.

Instant Gratification

This section is designed to get you playing sounds in the shortest amount of time and provides only a partial explanation of disk operations. For more complete instructions, see “Disk Menu” on page 355.

Power Up!

- Turn on the Emulator and wait for the following screen to appear.



If you have an E-Synth or an Emulator with the ROM bank added, you can select presets immediately. Use the Data Entry Control, INC/DEC buttons, Left/Right cursor buttons or the numeric keypad to change presets. That's it! If you have an Emulator without the ROM bank installed, you must load a bank into the unit. Go to the next section for instructions.

Loading a Bank from the Hard Disk

Loading a bank of sounds makes an entire collection of different presets immediately available.

To Load a Bank from the Hard Disk:

1. Press the **Load** function key (F4) from the main screen shown above. The following screen appears.

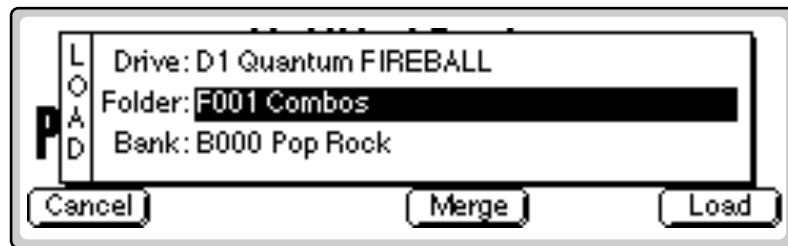

The display shows the hard disk drive information, the folders contained on the drive, and the individual banks contained in the displayed folder.

2. **Select the Folder** containing the desired bank. Using the Arrow cursor buttons, move the cursor to the Folder field and select the Combos folder.
3. **Select the Bank.** Move the cursor down to the Bank field and choose the General MIDI bank using the Data Entry Control, the INC/DEC buttons or the numeric keypad.
4. Press **OK** to load the bank. The bank is loaded and the first preset in the bank appears.

Loading SoundSprints

SoundSprint is a proprietary method of loading presets from a hard disk. As a preset is selected in SoundSprint, it is immediately loaded into the bank. If you have an EOS machine with a hard disk, try it out. See “SoundSprint” on page 23 for more information.

 The **Disk** button can be set to call up either **SoundSprint** mode or the **Last** screen you used in the **Disk Browser**. This preference is located under **Master, Setup, SCSI**.

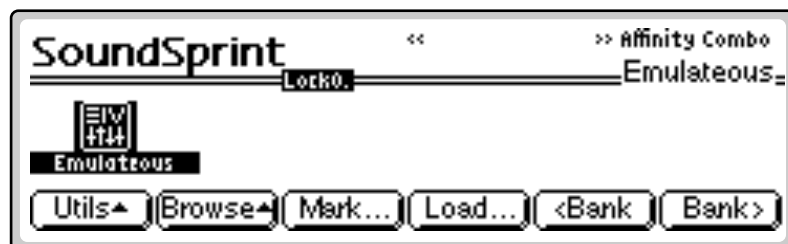

 Turn Sprint Off before continuing.

To Load SoundSprints:

1. From the main screen, press the **Sprint** function key (F2). The screen shown above appears.

Select a preset. Use the bank function keys (F5 & F6), the left/right cursor buttons, the previous/next buttons or the Data Entry Control to select new presets. The previous and next presets in the folder are shown in the upper right of the SoundSprint display window.

As you explore the SoundSprint presets be sure to try out the controllers such as sliders and wheels. EOS machines containing a hard disk have a special folder of Sprint presets.

To Turn Off SoundSprint Mode:

1. Press the **Utils** function key (F1).
2. Press the **SprntOff** function key (F5).

Selecting Presets

The currently selected preset is displayed on the main screen showing the preset number (as it appears in the currently loaded Bank) and its name. EOS provides several methods for selecting presets.





To Select a Preset:

- Use the Data Entry Control to quickly scroll through the presets.
- Use the Left and Right cursor buttons or the INC and DEC buttons to scroll through them one at a time.
- The Page buttons to scroll through them ten at a time.
- The numeric keypad to punch in the preset number and then press the "Go" button to confirm the selection.

When using the numeric keypad to select presets, you select a preset by entering a 1, 2 or 3 digit number. If fewer than three digits are entered, you must press the Enter or Go button after selecting the number. For example, you could select preset number 3 in any one of three ways:

1. Type "3." A window pops up asking you to confirm the preset number. Press the "Enter" button or "Go" button.

 Press Assignable Key 3 (default setting) to jump between the RAM and ROM preset locations if you have an E-Synth.

 *The more sound RAM you have in the unit, the larger the bank size can be and the more presets you can have in the bank at once.*



2. Type "03." A window pops up asking you to confirm the preset number. Press the "Enter" button or "Go" button.
3. Type "003." (You do not need to press the "Enter" button or "Go" button when entering all three digits of the preset number. Because there are only three possible digits, EOS knows that you're done.)

Presets are contained in the bank you loaded earlier so they are instantly accessible when selected, unlike SoundSprint presets, which take a second or two to load from the hard disk.

The next and previous presets are displayed in the upper corners of the screen. The next preset is displayed in the upper right hand corner, the previous preset is shown in the upper left hand corner.

Lock Button

The +/- button has an alternate function as a digit "Lock" button. When used as a lock, it sets the number of digits that you must enter to change a preset using the numeric keypad. Locking 1 digit (Lock 1 mode) requires you to enter the remaining two digits, but gives you a selection of 100 presets. Locking 2 digits requires only a single button press, but reduces the selection range to 10 presets. Press the Lock button repeatedly from the preset selection screen to rotate through the modes.

After entering the first digit in Lock 1 mode (meaning you need to enter 2 digits to select the preset by number), a popup window appears listing the ten presets in that rank. Use the Page buttons to select the next or previous ten presets. Use the cursor buttons to select a preset in that rank.

- The Lock button can be used to set the current rank of ten Bookmarks in SoundSprint mode. Press and Hold the Lock button and select a number to change the rank.

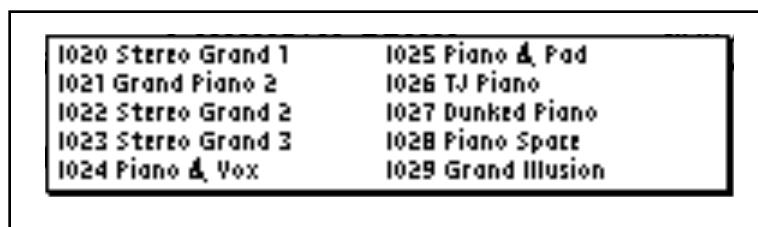

If you are in the Lock 1 mode and you only enter one digit, a message pops up asking you to confirm the preset number. You must press the Enter or Go button to confirm the selection.

For example, to select preset number 3, type "3." A window pops up asking you to confirm the preset number. Press the "Enter" button or "Go" button.

 Save to an Empty Bank if you have edited presets and want to save the old bank as well as the edited bank.

Saving

When presets are loaded into the bank, you are free to edit any parameter in any preset. When you have everything the way you want it, SAVE the entire bank to the hard disk. Since nothing is made permanent until you Save it, you can play around with the presets to your heart's content without worrying about ruining something.

When you get something you want to keep, then it's time to Save. If you don't save the bank, **all changes will be lost** as soon as you switch off power or load another bank.



To Save a Bank:

1. From the Main screen shown above, press the button directly under "Save..." on the screen (F5). The following screen appears.

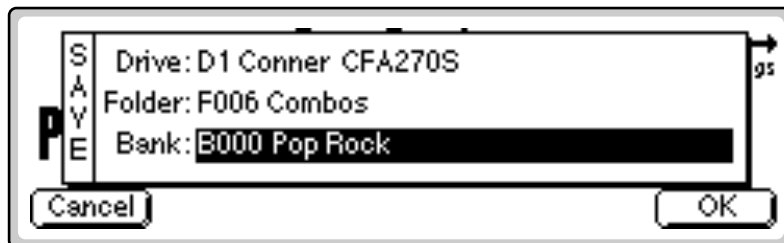



2. **Select the Bank location.** The bank field defaults to the bank currently loaded. Press OK to overwrite the bank or select an empty bank if you want to save the bank as a new bank.

You can also save the bank to another folder or disk drive (if connected). Use the up/down cursor buttons to advance the cursor to the Folder or Drive field, then select the new destination.

3. Remember that Saving is permanent, so think twice before pressing OK. Press OK to Save the bank or Cancel to abort the operation and return to the main screen.

 To save a single preset to a bank see "Export Preset" in the Preset Manage module.

 The arpeggiated notes can be recorded into the sequencer and are transmitted on the MIDI Out port.

 The arpeggiator continues playing on the current MIDI channel if you switch to Multi mode.



Arpeggiator

An arpeggiator moves a pattern of notes sequentially over a range of the keyboard. EOS provides a performance-oriented arpeggiator which is powerful, yet quick and easy to use. It has several features including tap tempo, octave extension, note value divisor and control over how the extensions are played (up, down, or up *and* down or random). The arpeggiator plays on the Basic Channel and remembers the order of played notes.

To Access the Arpeggiator:

1. From the main preset selection screen, press the **Mode** function key (F6). A new set of function keys appears.
2. Press the **Arp** function key (F5). The arpeggiator will be enabled and the function keys now control the arpeggiator functions.

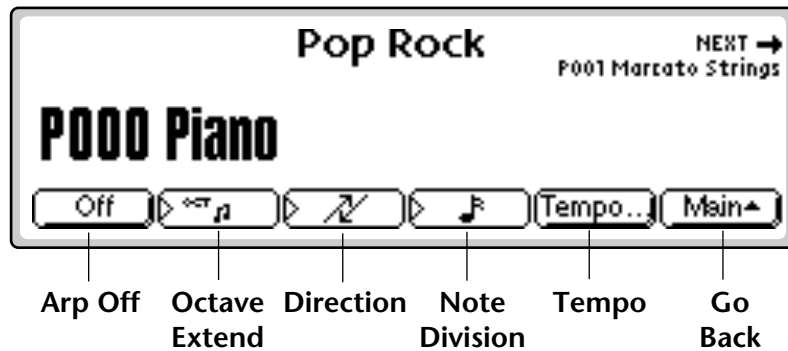

Octave Extension. The extension control shifts the arpeggio up the specified number of octaves each time the pattern is repeated. For example, suppose you played C2 with an Octave Extension value of 2. The arpeggiator advances the pattern 2 octaves in the direction specified. The extension can be set from 0-3 octaves.

To Set the Octave Extension:

- Press the **Octave Extension** button (F2) to toggle between values.

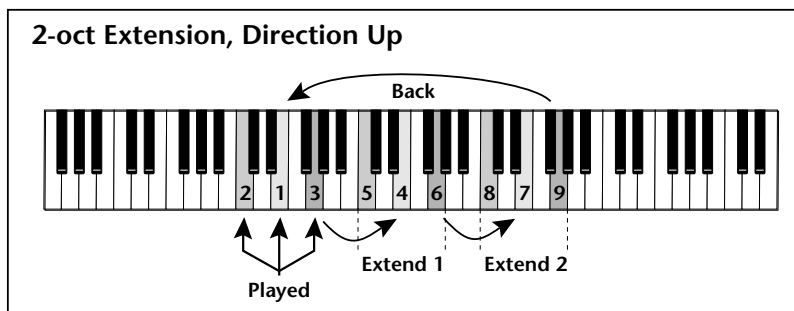

Arpeggiator Direction

Up ↗

Down ↘

Up/Down ↗↘

Random - - - -

Direction. The Direction parameter determines the direction or pattern of the arpeggiated notes. The held notes can be played forward, backward in an alternating forward/backward order or randomly. This setting also affects the order of the octave extensions.

☞ To Set the Arpeggiator Direction:

- Press the **Direction** button (F3) repeatedly until the desired direction is displayed on the screen. See the illustration at left for a description of the direction display.

Division. The speed of the arpeggiator is determined by both the tempo and the tempo divisor. The following divisors are available: 1/2 note, 1/2 note triplet, 1/4 note, 1/4 note triplet, 1/8 note, 1/8 note triplet, 1/16 note, 1/16th note triplet, 1/32 note, 1/32 note triplet. The division is particularly useful if you are synced to an external MIDI clock.

Triplets. Access the arpeggiator from **Multimode** and turn Triplets **On**. Triplets will remain on even if you switch back to Omni or Poly modes.

Tempo. The Tempo parameter, used with the Division parameter, determines the speed of the arpeggiator. There are two ways of defining the arpeggiator tempo; by entering it numerically or by using the Tap Tempo feature.



☞ To Enter the Tempo Numerically:

1. Press the **Tempo** function key (F5) to access the Arpeggiator Tempo screen.
2. Place the cursor over the tempo field and **enter the desired tempo** using the Data Entry Control, INC/DEC buttons or the Numeric Keypad.
3. Press **Done** (F1) or **OK** (F6) to return to the main Arpeggiator menu from the Tempo submenu. If you changed the status of the Sync function, it will be saved to EEPROM.



You can control the arpeggiator using an external MIDI Clock by setting the sequencer to an external clock (Sequencer, Global, Setup).



The arpeggiated notes can be recorded into the sequencer and are transmitted on the MIDI Out port.

To use the Tap Tempo function:

1. Press the **Tempo** function key (F5) to access the Arpeggiator Tempo screen.
2. **Tap the F4 button** at the desired tempo at least four times to define a new tempo. After the first four taps, the tempo updates the average tempo with each subsequent tap.
3. Press **Done** (F1) or **OK** (F6) to return to the main Arpeggiator menu from the Tempo submenu. If you changed the status of the Sync function, it will be saved to EEPROM.

ReSync! Resets the Arpeggiator clock at the exact moment the Resync button is pressed. This lets you synchronize with another beat as you play, even if the two clocks are not locked together.

Key Sync/Free Run. The Sync parameter defines when a note is played in relation to when the key is pressed. When set to Key Sync, the note sounds the instant a key is pressed. When set to Free Run, the note will not sound until the next arpeggiator clock cycle. The new Sync value is saved to the internal EEPROM.

The arpeggiator and sequencer use the SAME CLOCK and tempo. Changes in either menu will affect both functions.

To Arpeggiate:

1. Press the **Mode** function key (F6) from the preset selection screen. A new row of function keys appears.
2. Press the **Arp** function key (F5). The arpeggiator is enabled and the function keys now control the arpeggiator functions.
3. **Play a chord.** The notes you are holding should now be arpeggiating. Change the note division or go to the tempo submenu to change the speed. Explore all the arpeggiator controls. Have fun!
4. Press **ArpOff** (F1) to turn off the Arpeggiator.
Note: You can leave the Arpeggiator menu with the Arpeggiator on. Simply return to the Arp menu to turn it off again.
5. Press **Run** to start and **Stop** to stop arpeggiating. Press **Done**, **OK**, **Exit** or **Enter** to leave the Arpeggiator.

From Multi mode, the Arpeggiator window appears as shown below. The functions are identical.



Keyboard Modes

The keyboard modes are receiver functions, processing MIDI (or keyboard action on an E4K or E-Synth Keyboard) and are designed as easy to use performance features.

To Access the Keyboard Modes:

1. Press the **Mode** function key (F6). A new set of function keys appears.



Whole

Normal mode where the keyboard is not split or layered. This button puts EOS in Omni or Poly Mode.

Layer

This mode places both presets across the entire keyboard at once. Selection and Transpose operate exactly the same as in Split mode. *See Split.*

Split

The preset assigned to the MIDI Basic channel is placed on the lower half of the keyboard and the preset assigned to the Basic channel + 1 is placed on the upper split (for details about the Basic Channel and how to set it, see “Basic Channel” on page 103).

 *On a split keyboard, the Arpeggiator will play on the preset that was selected when the arpeggiator was turned on.*

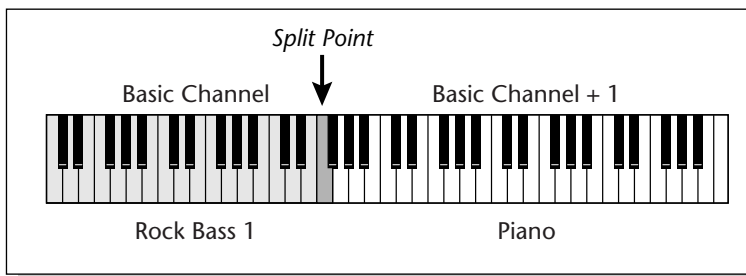

To Set the Keyboard Split Point:

1. Press the **Mode** button (F6) from the main preset screen. The Keyboard submenu appears.
2. Press the **SetSplit** function key (F4). The display asks you to play a key.
3. **Play a key** on the keyboard you want to be the first key of the upper preset.

To Change and Transpose Presets in Split Mode:

When in Split mode, the display appears as shown below, with both split presets shown (upper is always on top). The currently selected preset is ALWAYS shown in large **bold** type.

1. Use the Data Entry Control or INC/DEC buttons to change the **Preset** shown in **Bold**.

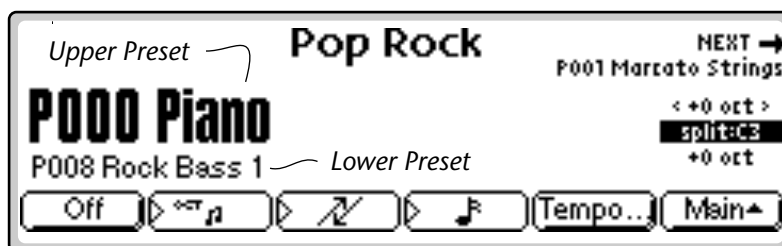
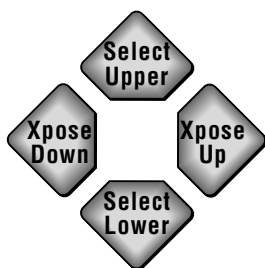



2. Use the left and right cursor buttons to **transpose** the selected **Preset** up or down.



The Upper Preset is ALWAYS on top of the lower preset in the display.

 Pan ADDS to the pan setting made in the voice and is not an absolute pan setting.

 The optional MIDI channel expander card allows 32 channel operation on older EOS machines having a single MIDI input port. This option is standard on E4X, E4XT Ultra and E-Synth Ultra.

 Omni mode plays only the currently selected preset from any MIDI channel.

Multi

Multimode allows the Emulator to respond to multiple MIDI channels at once allowing you to play multiple MIDI channels simultaneously. For detailed information and instructions on operating in Multimode, see Multimode on page 106.

Selecting Multi Mode:

- Press the **Mode** function key (F6) to turn on Multimode and display the Multi mode screen. See the following illustration.

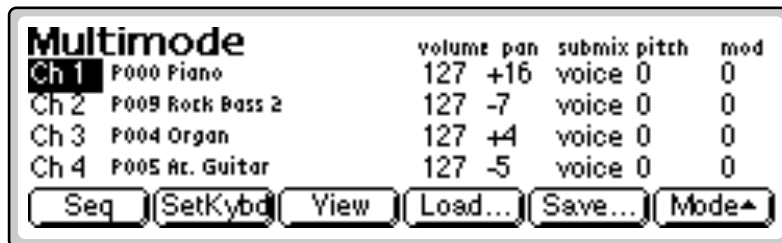

To Change Channel Settings in Multimode:

1. Press the **View** function key to select MIDI Mix view. The MIDI Mix screen displays and defines the preset, volume, pan settings and output assignments for up to 32 MIDI channels.

This is useful for fine tuning multi-timbral sequences. This screen also lets you override the output channel programmed in the voice. Any volume, pan and preset changes made over MIDI are reflected in this display.

- Volume = MIDI continuous controller channel #7
- Pan = MIDI continuous controller channel #10

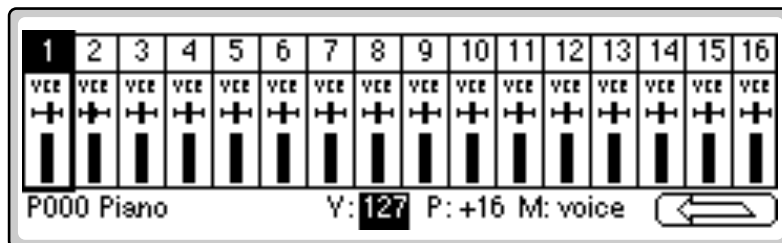

2. Select the desired MIDI channel using the up/down cursor buttons.
3. Select preset, volume, pan or the output assignment using the left/right cursor buttons. **Change the parameter values** using the Data Entry Control, the INC/DEC buttons, or the numeric keypad.

To Return to Omni or Poly Mode:

1. Press the **Arrow** function key (F6).
2. Press the **Mode** function key (F6).
3. Press the **Whole** function key (F1).

The Basics

1

Definitions

How Sounds are Organized

It is important to understand how sounds are organized in order to make best use of the instrument in the shortest possible time. Many terms will be introduced now that show up later in the manual.

You can think of the Emulator as a collection of sound organizing modules, all contained within the currently loaded bank. Let's take a closer look at what makes up this information, and how it is transferred from one section of the instrument to another. The Disk is the largest element in the hierarchy; the Sequence is the smallest element. The following gives a brief description of the EOS hierarchy.

Disk Drive. Floppy Disk, Hard Disks, CD-ROM Drives, Optical Drives, ROM Chips, etc.

Folder. Used to group and organize collections of Banks.

Bank. All samples, voices, and presets - Everything that resides in RAM (memory).

Preset. One complete keyboard setup containing one or more voices.

Voice. One complete sound which contains one or more samples with keyboard and velocity settings and all programmable synthesizer parameters.

Sample. An individual digital recording with a name, sample rate and looping information.

Sequence. A sequence of key depressions, controller movements, program changes or system exclusive MIDI data. Up to 50 sequences can be stored with each bank, but sequences can also be exported as Standard MIDI Files or as Emulator sequences. They can even be saved to Flash RAM.

To explain the hierarchy, we'll begin with individual elements, then work our way through the system.

 *The total amount of available sampling time can be divided up any way you like—one long sample, lots of short samples, a few medium samples, or any combination thereof.*

The Sample

Loading in any sound, in mono or stereo, creates a sample, the raw material with which the Emulator works.

The term sample commonly means two different things:

1. A digital recording of a complete sound, or
2. Each snapshot of the sound that makes up the complete sample.

In this manual, we'll assume sample means the complete recorded sound unless indicated otherwise.

You can modify a raw sample in several ways. A sample can be transposed up or down in pitch to cover a particular range of the keyboard making it unnecessary to record a sample for every key. Sample editing might consist of Looping a sample (allowing even short samples to play indefinitely), Truncating (cutting off unneeded parts of a sample, thus saving memory), or any of a number of digital processes that actually change the raw sample data.

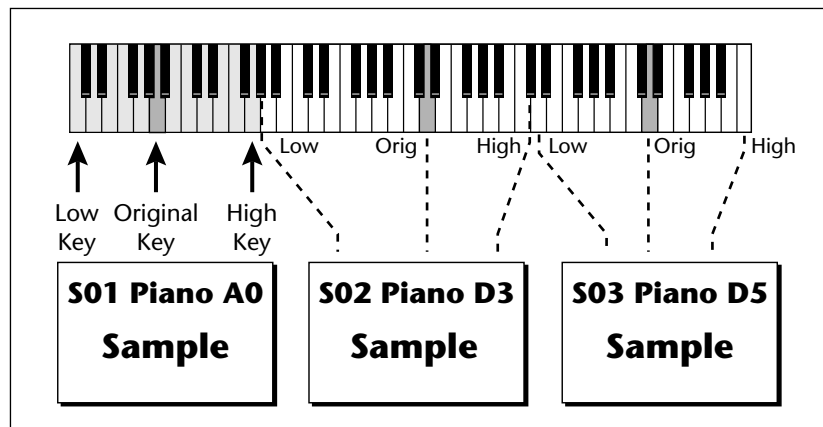

You can name samples also. It is usually a good idea to include the original pitch in the name so that you can place it on the keyboard later at the proper pitch. A bank can hold up to 1000 samples.

Voices

A voice is a complete sound that can be assigned to a range of the keyboard. A sample is the sound-generating portion of a voice. You can think of a voice as a complete instrument consisting of one or more samples, which can then be used as a building block in constructing more complicated presets. A voice consists of one or more samples, a dynamic filter, a dynamic amplifier, up to three 6-stage envelope generators, up to two multi-wave LFOs and up to 24 modulation routings called “Cords” to connect everything together.

 A voice can contain a single sample or multiple samples, whichever you prefer.

In one typical scenario, you might record several samples of an instrument (such as a piano), then place them into the same voice. Normally these samples would be placed side by side on the keyboard as in the following diagram. You assign the sample to a range by setting the original key, (which is usually the original pitch of the sample) a high key and a low key. The number of samples needed for a realistic emulation varies with the instrument, but in general, “more is better.”

When a sample is taken, it can be automatically placed into a voice with one sample. You can also place the voice (and its sample) on the keyboard.

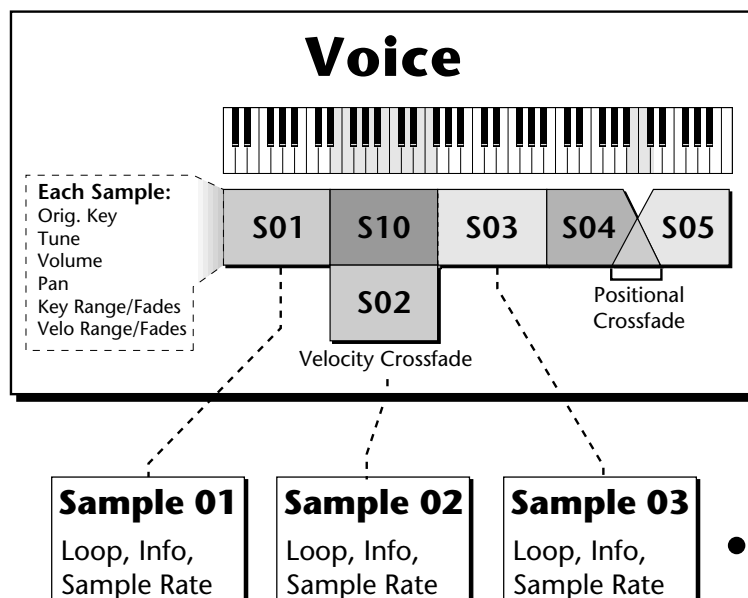

If more than one voice is assigned to the same range, then pressing a key in that range plays all the voices assigned to that range. Voices assigned to the keyboard can be crossfaded by their position on the keyboard, or the key stroke velocity. Voices can also be switched or faded depending on the value of a realtime controller such as a modulation wheel, an LFO or an envelope generator.

The Preset

A voice can be assigned to a single note on the keyboard, or transposed polyphonically to cover a wider keyboard range. A preset is one entire keyboard setup consisting of one or more voices. The process of assigning, and optionally transposing, samples to specific ranges of the keyboard is called making a preset. Making a preset is a three-step process:

1. Create the preset and give it a number and name.
2. Place voices in different keyboard ranges. For example, with six voices you could assign each voice to cover one octave of a six octave keyboard. A voice can be assigned more than once within a given preset, and assigned to more than one preset. Each preset can have up to 256 voices.
3. Choose from a number of available options that further define the preset. Some examples are: assigning samples to partially or fully overlap other samples, thus producing doubling effects, or assigning dynamic control to individual voices in a preset. Overlapping voices can be crossfaded using any modulation source. You can modify voice parameters and set up MIDI and dynamic processing parameters.

EOS allows you great flexibility in the way you construct presets. Consider this — you can assign multiple samples to the keyboard inside the voice or assign single sample voices to the keyboard. Unless you specify otherwise, only one sample is assigned per voice. In this case you would assign voices (and the single sample each one contains) to the keyboard and create presets. On the other hand, you may want to create finished voices before you start designing presets and treat the voice as your finished sound. In this case, the preset can be used to crossfade, layer or switch multiple complex voices.

SoundSprint

SoundSprint is a special mode used to load presets quickly and automatically within a folder as you browse through them. Presets are loaded in the background while the keyboard remains active with the last preset. Loading time varies with the size of the preset, but most presets load in one to three seconds.

Presets loaded via SoundSprint are placed at the top of the bank memory and are assigned preset numbers 990-999.

You can load up to ten SoundSprint presets in RAM and these can be selected instantly. Once you load more than 10, the oldest Sprint preset is erased. SoundSprint will not overwrite a preset that has been loaded in the conventional manner and a "Memory Full" message will be displayed. See "SoundSprint™" on page 376 for additional information.

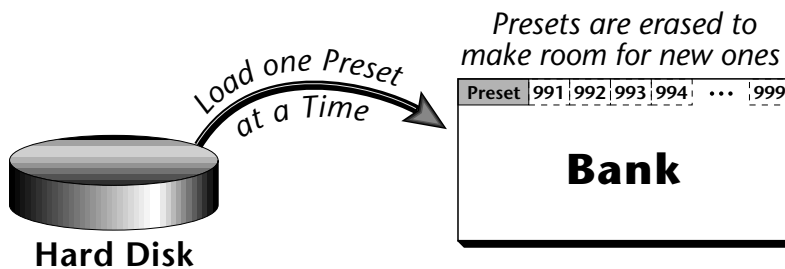

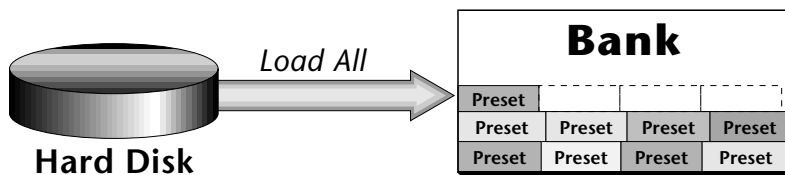

SOUNDSPRINT

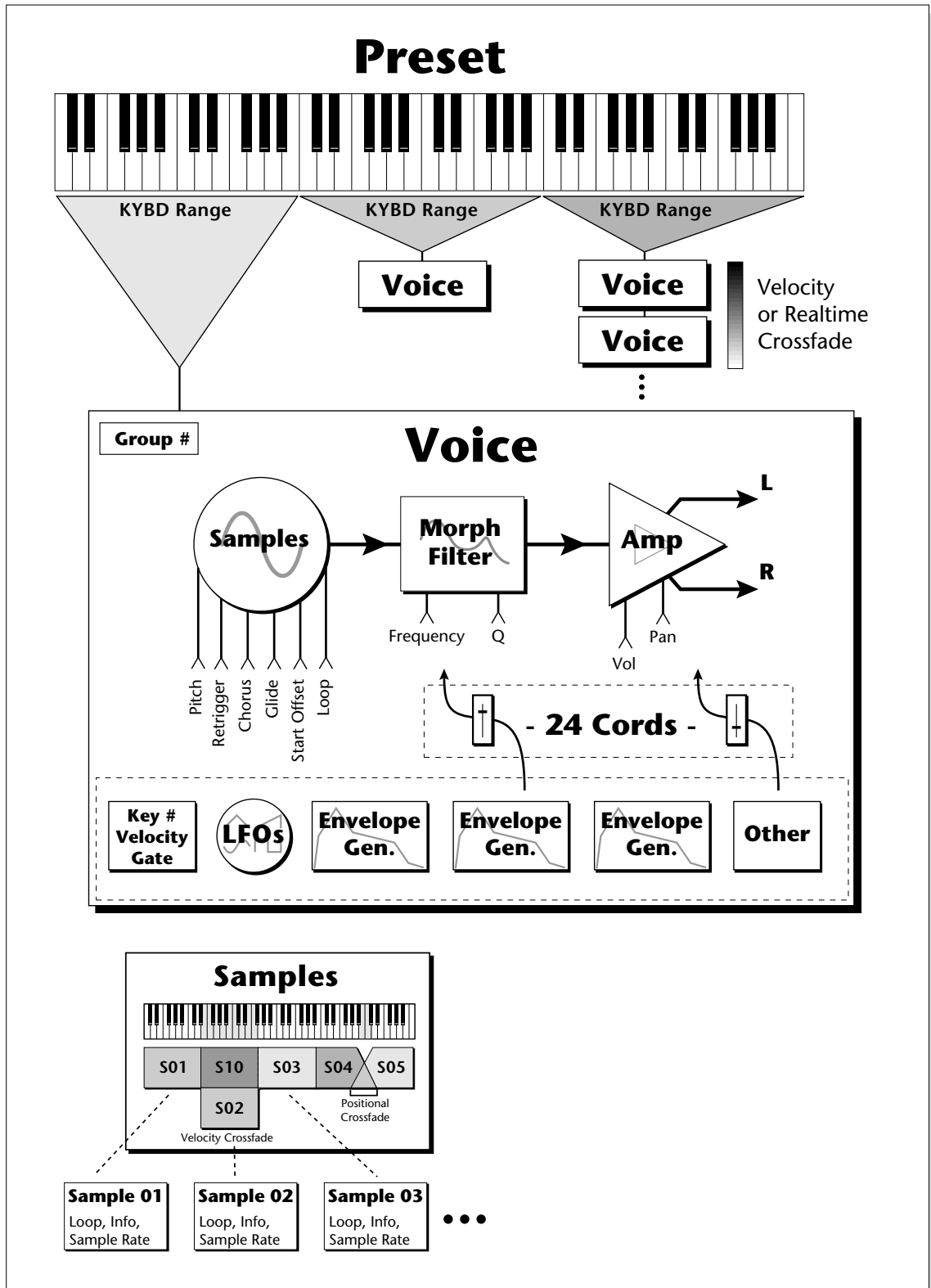

LOAD BANK

1 - The Basics
Preset Diagram



 Up to 100 Bookmarks can be saved to nonvolatile Flash RAM.

Bookmarks

When in SoundSprint mode, you can attach Bookmarks to your favorite presets so that they can be selected instantly with a single or double key press. You can store up to 100 bookmarks and save them to nonvolatile Flash RAM.

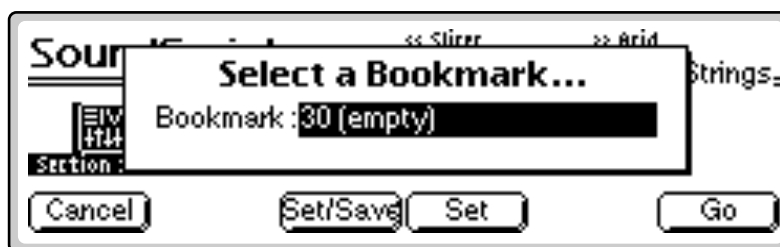

To Set a Bookmark:

1. **Select a preset.** From the SoundSprint Browser, use the left/right cursor buttons to select the preset you want to bookmark.
2. Press the **Mark...** function key (F3). The screen shown above appears.
3. **Select a bookmark location** using the Data Entry Control or INC/DEC buttons.
4. After selecting a location, press the **Set** function key (F4) to set the bookmark. Press the **Set/Save** function key (F3) if you want to save the bookmarks to nonvolatile memory.

The numeric keypad selects a bookmark from the rank of 10 you last selected with the Lock engaged.

5. Press the **Go** function key (F6) to go to the currently selected preset. Press **Cancel** (F1) to cancel the operation.

Alternate Method to Set a Bookmark: (Using the Set button)

1. The first digit must be **Locked** for this trick to work. Press the \pm key so that **Lock0** appears in the display.
2. From the SoundSprint Browser, **select the preset** you want to bookmark using the left/right cursor buttons.
3. **Press and hold the Set button** located to the right side of the numeric buttons. While holding the Set button, **press one of the numeric buttons**. A pop up dialog box will inform you that the bookmark is set.

To Select a Bookmark:

- From the SoundSprint Browser, **press the numeric button(s)** corresponding to the bookmark you want to select. For example, if you want to select the preset at bookmark number 9, **press 9** on the numeric buttons. The preset is selected.

1 - The Basics

The Bank

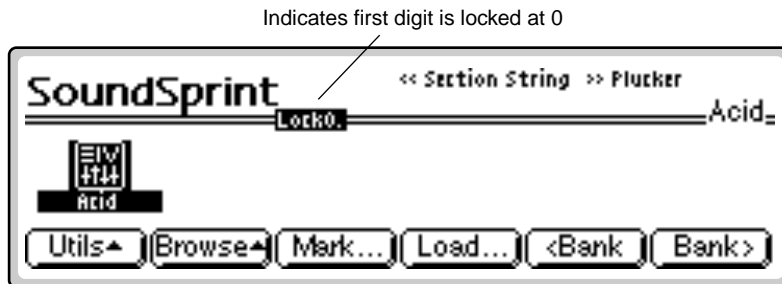

☞ To Lock the first digit of the two digit Bookmark Number:

- Press and hold the **Lock** button (located to the left of the numeric buttons) while pressing one of the numeric buttons to lock the most significant digit.
- Press the **Lock** button by itself to turn Lock mode On or Off. The lock indicator on the display is shown in the previous illustration.

With Lock Off, two digits must be entered to select a bookmark. For example, to select bookmark 9, you would **press 0**, then **9**.

With the most significant digit locked, only one button press is required to select a bookmark.

☞ To Select another Rank of 10 Bookmarks:

- Press and hold the **Lock** button and press one of the numeric buttons. The display informs you of which rank of 10 bookmarks is now selected.

 A bank can hold up to 1000 presets.

The Bank

The bank contains samples, voices, presets and sequences. Everything that is loaded into the Emulator is part of the bank. Although the memory is volatile, meaning that the data disappears when you turn off power, all bank data can be saved permanently to a hard disk drive or other media. The number of samples that can be loaded into a bank at once is dependent on the amount of sample RAM you have installed in your Emulator.

Folders

Just like on a computer, folders help keep banks organized. A folder can contain up to 100 banks (0-99). You can use folders to organize your sound banks by including all the banks used for a particular project in a folder. The number of folders in a disk depends on the size of the disk. As an example, a one gigabyte hard disk can hold up to 96 folders.

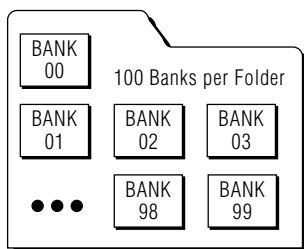

The Internal Drive

A disk drive is a memory storage device that stores banks of data. The floppy drive is used mainly to update the operating system software. (The operating system consists of the instructions that tell the Emulator what to do.) Other types of disk drives, as described below, can connect to the Emulator to provide efficient sound storage.

Floppy Disk Drive: The floppy disk drive requires 3.5", double-sided, high-density (1.4 MB) floppy disks. As new enhancements are developed, the new software is distributed on floppy disks. The floppy drive is used to update the operating system software. This software can be copied into Flash RAM and made a permanent part of the Emulator itself.

It is also ideal for transferring sequences to and from a computer-based sequencer. With large bank sizes of 4-128 MB, the floppy disk becomes impractical for backing up sound data, although it can be used to save or transfer small sound banks in a pinch.

EOS accepts 2 kinds of floppy formats. DOS formatted disks allow multiple files per disk and are compatible with PC and Macintosh computers. EOS formatted disks allow one bank to be spread over multiple disks.

Note: The Emulator can format floppies in EOS format only. DOS floppies must be formatted on a PC or Mac computer or purchased preformatted. EOS cannot read Macintosh floppies, but fortunately the Mac can read and format DOS floppy disks.

To Update the EOS Software:

Since the EOS operating system is stored in Flash ROM, it can be easily updated to add features or to fix *bugs*. The following procedure explains how.

1. Turn off power.
2. Insert the floppy disk into the drive.
3. Turn on power.
4. Press Enter to update or Exit to cancel.
5. Wait for the Emulator to update its firmware.
6. Re-initialize EEPROM. (This should be done after a software update to "clean the slate". It resets the Master menu preferences and other bits.)
 - a. Press **Master**
 - b. Press **Utils**
 - c. Press **Tests**
 - d. Enter the Secret Password: **1-3-5-8**, then press **OK**.
 - e. Press **More**
 - f. Press **InitEE** The display reads, "Initialize EE?"
 - g. Press **OK**. The display reads, "Saving System"
 - f. Press **Master** to exit diagnostics mode.
7. Recalibrate the Emulator controls. See "Recalibration" on page 68.



Check the E-mu web site at: www.emu.com for the latest software updates & downloads.

Internal Hard Disk Drive: A hard disk provides the advantages of much higher memory capacity and far faster access time than floppy disks. However, the hard disk cannot be removed and its data must be backed up to another medium for safekeeping.

IDE Drives: The Ultra series Emulators can make use of an internal IDE hard disk. An IDE drive has several advantages including: low cost, high capacity, low noise and it doesn't use up a precious SCSI ID number. *Order IDE installation kit #6303. This includes everything needed except the IDE drive.*

External Drives

Emulators are equipped with SCSI (Small Computer Systems Interface) connector(s) on the rear panel. This interface is commonly used in the computer industry, so many devices made to work with computers—particularly mass storage devices—will also work with Emulators. Here are some of the types of mass storage devices that can be connected to the Emulator using the SCSI connectors.

Hard Disk Drive: A hard disk provides the advantages of high memory capacity and fast access time. Transferring data is quite straightforward. However, you cannot remove a hard disk and replace it with another one—the disk is a permanent part of the drive. There are some important cautions involved with hard disks:

1. Hard disks are sensitive to extreme mechanical shocks. If your hard disk falls off a keyboard stand, chances are the hard disk will be damaged.
2. Hard disks have reached a very high level of reliability. However, they can fail from time to time (as can any part of a computer), so any data should be backed up periodically on some other medium.

Removable-media Hard Disk Drives: These are similar to standard hard disk drives except that the disk itself can be removed and replaced with another disk (similar to floppy disks). Disk densities can range from 44MB to well over 1 Gigabyte (GB) per platter. Removable-media hard disk drives make it easy for you to build a sound library of unlimited size and are quite handy for transferring sounds between machines. They're also perfect for backups because you can remove the media and keep it in a safe place.

CD-ROM Drive: A CD-ROM is a playback-only mass storage memory device whose capacity is approximately 660MB. Quality CD-ROM libraries are available from several companies (E-mu Systems, InVision, Northstar, Q-Up Arts and many others). These can be loaded into the bank just like a hard disk.

Magneto-Optical Drive: These high speed, high density storage devices are ideal for storing large amounts of sound data. Typically a magneto-optical drive can hold upwards of 300 MB per side and the removable cartridges can be used over and over. Disk access time is comparable to a normal hard disk. Although you can read and write to these drives, they are generally slower than most hard disks.

 Use the "Mount Drives" utility whenever an external SCSI device does not appear in the display.

 *The Memory Configuration control (Master, Setup, Memory), allows you to balance the allocation of Preset Memory between the Sequencer and Presets.*

 *Contact your E-mu dealer if you wish to upgrade your CPU RAM.*

Sample Memory & Preset Memory

EOS presets use two separate memory locations — Preset Memory and Sample Memory. Preset memory (also called CPU memory) is used to hold both preset parameter information and sequences. (The ratio between presets & sequences is user adjustable — see sidebar tip.) The amount of Preset Memory determines the number of presets and sequences you can have in your Emulator.

Preset memory on the e-64, E-IV, E4K, and E-6400 is about half a megabyte. The E4X, and E-Synth come standard with 2.6 MB of usable preset memory. Ultra models have about 4 MB of preset memory. Sample memory contains the actual sample data and can vary from 4 MB to 128 MB. Because presets use far less memory than do samples, less preset memory is needed.

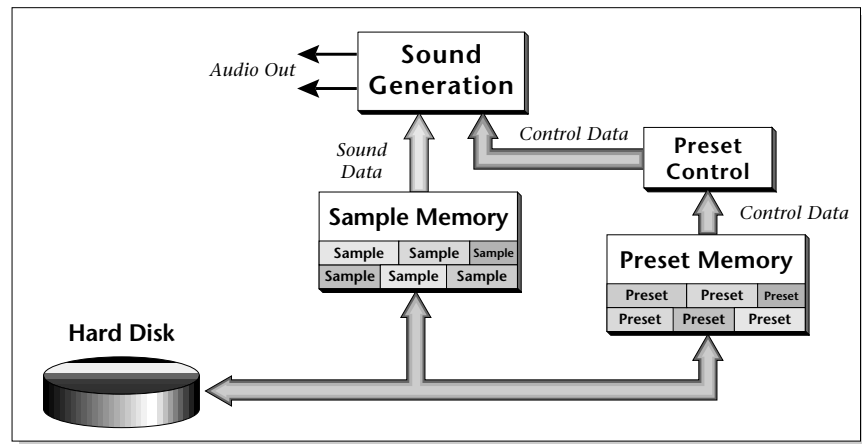

Sound ROM & Sound RAM

Sound ROM is a standard feature on E-Synth and one of the available hardware upgrades for other EOS instruments. Although the samples themselves are in ROM and cannot be changed or modified, the Presets with all their keyboard mapping and synthesizer parameters can be changed because they are stored in non-volatile Preset Flash RAM. Flash RAM contain 256 to 1000 presets depending on the amount of Flash RAM you have installed. Flash presets are located immediately after RAM preset 999 (1000 - IXXX) in the preset numbering scheme.

Five Types of Memory

The Emulator uses up to five different memory types. It *CAN* be confusing.

- **Sample RAM** - 4-128 MB. Contains samples loaded from the hard disk.
- **Sample ROM** - Permanent ROM samples. Optional on all but E-Synth.
- **Preset RAM** - 1-8 MB of dynamic RAM. Used by CPU, and also contains presets and sequences loaded from the hard disk.
- **CPU Flash** - Normally used to store presets for ROM or S-Flash banks.
- **Sound Flash** - Optional flash SOUND memory to store your own banks.

 *Preset Flash can also be used to store presets for HD based sound banks. However, this can be confusing since the proper samples may not be loaded into Sample RAM when the preset is selected.*

1 - The Basics

Flash Sound RAM

Tip #1: Storing RAM based presets in flash can be useful to store preset “templates” that do not have samples associated with them. Bear in mind that unless you have Sound ROM or Sound Flash installed, the presets may NOT point to the correct samples.

Tip #2: Flash presets can also be used when you’re working on a RAM based preset which uses a lot of sample memory. Normally you would **Save** the bank, but this can take quite some time with a really large bank. If you’re only modifying the preset parameters, you can **Copy** the preset to **Flash** and save time. Later you can **Copy** the preset back to RAM then **Save** the bank normally.

Tip #3: Flash memory is also handy to store your favorite sequences. Copy the sequence to a Flash (z) sequence location.

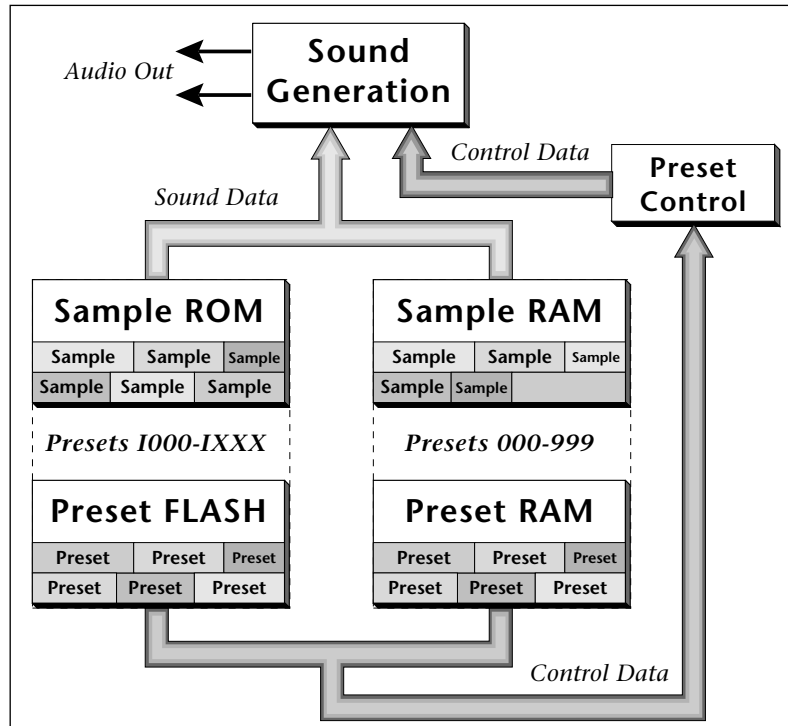

Sample ROM and Preset Flash are both retained when power is disconnected. Sample RAM and Preset RAM are not retained with power disconnected and must be re-loaded from the hard disk.

Normally, preset data stored in Flash RAM uses the samples stored in ROM. However, you can also create RAM presets (saved and loaded from disk) which use the permanent ROM samples.

Presets stored in Flash RAM can point to RAM based samples also. **This mode of operation can be CONFUSING** however, because there is no guarantee that the correct samples will be in RAM when the flash preset is selected.

Copy Presets to and from a floppy or hard disk using special Flash memory utilities which are located under Master, Bank, Flash. See “Flash Utilities” on page 73 for details.

Flash Sound RAM

Flash Sound RAM is yet another upgrade that adds either 8 MB or 16 MB of non-volatile Sample storage. Unlike the Sound ROM option, both samples and presets are stored in Flash RAM.

You can save entire banks to Flash RAM just like ordinary Sound RAM, but unlike ordinary RAM, Flash RAM retains its memory when the power is turned off. Flash RAM lets you create a custom ROM bank that is reliable and always available. If both Sound ROM and Flash Sound RAM options are installed, the 256 available presets are shared between them.

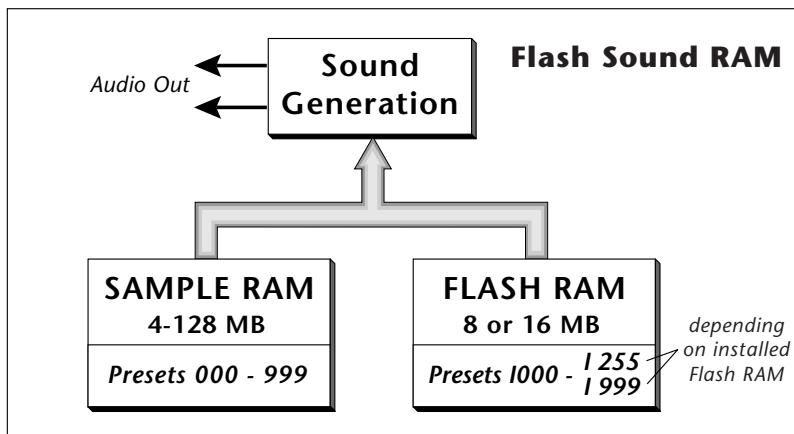

Sample Numbers

The Emulator contains two internal SIMM sockets for use by Sound ROM and Flash Sound RAM. These special sockets are designated X and Y. If you have either Sound ROM or Sound Flash RAM installed, you'll notice that the samples stored in these locations have the prefix X or Y before the sample number. (Press Preset Edit to see the sample assignments) Similarly samples stored in main sample RAM use the designator "S" before the sample number, as in "S003".

Using Preset Flash Memory

The Preset Flash memory comes pre-loaded with 256 Presets. If you need to reload the factory presets, use the following instructions.

To Upload the Factory Presets into Flash:

1. **Power up** the machine and wait for it to finish booting.
2. Press the **Master** button.
3. Press the **Setup** function key (F3).
4. Press the **Memory** function key (F6).
5. **Set the Memory Configuration.** To load the 8 MB FLASH Presets you'll need at least 85K of Preset Memory. To load the "Big RAM" Presets you'll need at least 507K of Preset Memory.
6. Press the **Save** function key (F6).
7. Press the **Master** button again to exit the Master module.
8. **Insert the floppy** disk containing the factory presets into the drive with the label side towards the center of the unit.
9. Press the **Load** function key (F4). The pop-up Load window appears.
10. **Set the Drive to "Floppy"** using the cursor buttons and Data Entry Control.

11. Press the **Load** function key (F6).
12. When the bank has finished loading, press the **Master** button.
13. Press the **Bank** function key (F2).
14. Press the **Flash** function key (F6).
15. Press the **RAM→F** function key (F3). A warning screen appears advising you that you are about to overwrite Flash RAM.
16. Press **OK** (F6) to write the bank to Flash RAM.

Using Sound Flash Memory

Sound Flash Memory is similar to a hard disk containing one bank. A bank is assembled in Sample RAM, then Saved to Flash Memory. Individual presets can be saved to Flash Memory using the Copy function in the Preset Manage module.

☞ To Save a Bank to Flash Memory:

1. **Erase the Bank**
 - Press the **Master** button.
 - Press the **Bank** function key (F2).
 - Press the **Erase** function key (F1).
2. **Load the Bank** you want to Save to Flash
 - From the main screen, press **Load**.
 - Select the **Drive, Folder and Bank** you want to Save to Flash, then press **Load**. The bank will load into RAM.
3. **Save the Sounds to Flash.**
 - Press **Save**.
 - Select **Flash Memory** as the drive you wish to Save to, then press **OK** (F6). The Samples will be stored in Flash Sound RAM.
4. **Mount the Drive.**
 - Press **Disk**.
 - Press **Utils** (F1).
 - Press **Mount** (F1).
5. **Erase the Bank...again**
 - Press **Master**.
 - Press **Bank** (F2).
 - Press **Erase** (F1).

6. Erase Preset 000

This operation deletes the empty preset in the P000 location of the bank so it won't get merged into your Flash Bank. Unfortunately, you must have at least one preset in the bank, so before deleting P000 we'll create a new empty preset at location 999.

- Press **Preset Manage**.
 - Press **New...**
 - Select destination preset **P999 Empty Preset**.
 - Press **OK**, twice.
 - Select **P000 Untitled Preset**.
 - Press **Utils (F1)**.
 - Press **Erase Preset (F1)**. Press **OK (F6)**.
7. **Merge the Presets.** Merging the presets into the bank will point to the correct locations in the Flash Sound Memory bank. The Emulator sees that the samples are in Flash Sound Memory and changes the sample numbers so they point to Flash.
- From the main screen, press the **Arrow** button, then **Load**.
 - Select the **Drive, Folder and Bank** you want to Save to Flash, then press **Merge**.
8. **Save the Presets.** Now that the sample numbers point to the samples in Flash Sound Memory, write the presets into CPU Flash memory using the Flash utilities.
- Press **Master**.
 - Press **Bank (F2)**.
 - Press **Flash (F6)**.
 - Press **RAM->F (F3)**. A warning screen appears.
 - Press **OK (F6)**. The presets are written into CPU Flash memory.

To Copy Flash RAM Presets to Disk:

1. Power up the machine and wait for it to finish booting.
2. Press the **Master** button.
3. Press the **Bank** function key (F2).
4. Press the **Flash** function key (F6).
5. Press the **F→RAM** function key (F4). A warning screen appears advising you that you are about to overwrite RAM.
6. Press **OK (F6)** to write to RAM.
7. Press the **Master** button to return to the main screen.
8. **Insert the floppy** disk into the drive if you wish to copy to floppy disk.
9. Press the **Save** function key (F5). The pop-up Save window appears.

1 - The Basics

Using Sound Flash Memory



Heed this warning if you have ROM or Flash presets already stored in preset Flash. Sound ROM and Flash Sound Memory share the same preset locations.

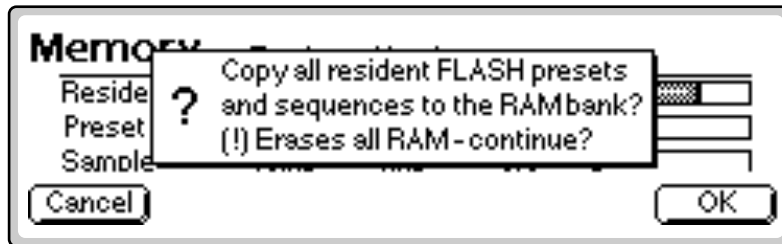

10. Press OK to continue.
11. **Select the destination** Drive, Folder and Bank for the flash presets.
12. When the parameters are properly set, press OK (F6). A warning screen appears warning you that you are about to overwrite a bank.
13. Press OK (F6) to save the bank to Disk or Cancel (F1) to cancel the operation.

To Copy Flash Sounds to Disk:

It might be a good idea to back-up the factory samples before you overwrite the Flash Bank with your own sounds.

1. **Power up** the machine and wait for it to finish booting.
2. From the main screen, press the **Arrow** function key.
3. Press the **Load** function key.
4. Wait for the bank to finish loading, then press the **Arrow** function key.
5. Press the **Save** function key.
6. **Select the destination.**

Modules

A module controls a particular set of functions. There are six main modules in EOS: Master, Disk, Preset Manage, Preset Edit, Sample Manage and Sample Edit. There is also a Sequencer submodule located under Master.

Activating a Module: To work with a module, you must first activate it. Press the button associated with the desired module.

Function Key Menus: Menus are selected using the function keys along the bottom of the display. Pop-up menus may also be used when a field being edited has a small number of choices.

Page Selection: Each module contains several pages which contain controls for additional functions.

In a graphical display, the different fields can be selected in the following ways:

- By pressing the cursor buttons (up, down, left, right).
- By turning the Data Entry Control.
- By assigning an assignable key to jump directly to the screen you want to edit.

Pressing the module button or the Exit button cancels any operation.

The Module buttons are located on the left side of the control panel. Each module affects a specific area of the Emulator's operation.

Disk: This module controls everything to do with the disk drives where sounds are stored. You can browse through the disks, examine their contents and audition sounds directly from a hard disk before loading. If you are looking for a specific sound, you can use the "Find" function to quickly locate it. See "Disk Menu" on page 357.

Master: This module contains functions that affect the entire machine, such as master tuning, headroom, master FX, output sample rate, LCD contrast, and much more. "Master Utilities" on page 65.

Sample Manage: This "recording studio" module records sounds from the outside world into the bank. Features include adjustable preamp gain, variable threshold setting, and adjustable sample rate and length. "Sample Utilities" on page 174.

Sample Edit: With this powerful module, you can edit a sample's length, loop (i.e. infinitely sustain) any portion of the sample and automatically find the best loop points using Auto Correlate. You can splice two different samples together, mix samples, or perform a variety of advanced digital signal processes on the sample. "Sample Edit" on page 193.

Preset Manage: This module handles the preset "housekeeping", allowing you to create new presets, copy them to any location, rename them or erase them. "Preset Manage" on page 245.

Preset Edit: This module lets you alter the synthesizer voice parameters, such as shaping the amplitude and filter dynamics or adjusting the keyboard dynamic response. Voices can be placed on the keyboard, moved around or shaped in just about any possible way. "Editing Presets" on page 253.

Sequencer: This module accesses the 48-track sequencer which is located inside the Master module. The Sequencer can be quickly accessed by holding the Set/Shift button (decimal point) and pressing Assignable Key 1. "Sequence Manage" on page 133.

Effects: This module controls the realtime FX processors. It is located in the Master and also the Preset modules, but can be quickly accessed by

holding the Set/Shift button (decimal point) and pressing Assignable Key 2. “Effects” on page 117.

SoundSprint: This function automatically loads presets as you browse through them. SoundSprint can be quickly accessed by holding the Set/Shift button (decimal point) and pressing Assignable Key 3. “SoundSprint” on page 23.

More Definitions

Saving

The RAM bank retains data only for as long as the Emulator is plugged in and turned on. Of course, we don’t expect you to leave the thing on all the time, which brings us to the subject of saving data.

Pressing the SAVE function key from the Disk module or Main Screen shuttles all the bank data (samples, voices, presets and sequences) to the drive of your choice. A hard disk permanently stores data so that even after turning off the Emulator, the disk stores a record of your work.

IF YOU DO NOT SAVE A BANK, ALL BANK DATA WILL BE LOST WHEN YOU TURN OFF THE MACHINE!

Do not wait until the end of a session to save. Save your work periodically in case of power failure or some other unforeseen circumstance that might erase the bank’s memory. Hard disks are not infallible. All hard disk banks should be backed up periodically to another hard disk or other media. Should you improve the preset or sample later, you can always replace the original with the revised version. And if something goes wrong, the original will still be available to save you the ordeal of starting from scratch.

Whenever you have done enough work that you would hate to lose it, **BACK IT UP!**

Default

A default setting is what we’ve judged to be a useful initial setting, and remains in effect until you change it. For example, if you create a new preset, the transpose setting defaults to “0.” Had the default value been “+12,” all new presets would be transposed up an octave until you change the value.

Icons

An icon is a little picture of an object such as a floppy disk, a hard disk, folders, banks, presets or samples. In the disk browser screens, icons are used as an easy way to identify and select the appropriate object. When an icon is selected, the image will reverse (black to white & vice-versa).



D8 Floppy Disk

This is the icon for the floppy disk drive

The Cursor

The cursor is a highlighted area on the display. It shows you the number or letter that will be altered if you enter data. Entering a new value overwrites the number or letter above the cursor, whereupon the cursor moves on to the next number or letter (if applicable). If the Emulator is expecting a two or three-digit number, in most cases you must enter all the required digits even if some of these are zeroes (called leading zeroes). For example, if the Emulator is expecting a three-digit number and you want to enter 8, you would enter 008. If it is expecting a single-digit number, entering 8 would be sufficient.

Data Entry Control & Increment/Decrement Buttons

In virtually all instances where the Data Entry Control selects options, the increment (Inc/Yes) and decrement (Dec/No) buttons duplicate the Data Entry Control. Press Inc/Yes to increase a value, or Dec/No to decrease by one value at a time.

Selecting

When the instructions say to select an option, you can use whatever method is most comfortable for you: the Data Entry Control, the increment/decrement buttons, the numeric keypad (if applicable) and, when naming, the keyboard keys. Some functions do not implement all these options. (You can't go wrong by trying, though. If a function doesn't respond to the numeric keypad, for instance, then pressing the keypad will have no effect.) Use the Data Entry Control or the INC/DEC buttons instead.

The Big Re-Cap

- A sample is a raw sound that is loaded into the bank.
- A voice is a complete sound, consisting of one or more samples, processed through the dynamic signal processors, that is mapped onto the keyboard.
- To create a new preset, make sure you have all the samples required for the preset, then assign combinations of voices from the bank to specific sections of the keyboard.
- After arranging a bank, it can be saved to one or more drives or to Flash Memory.
- Since loading from a hard disk fills the bank with samples, voices and presets, you can group these voices and samples into new presets, process the samples contained in particular voices, or alter existing presets.
- Presets loaded via SoundSprint are always placed in preset locations 990-999.
- Up to 50 sequences can be saved with the bank. An additional 50 sequences can be saved into Flash (if you have it). Flash sequences are designated by a "z" in front of the sequence number. Exported or Standard MIDI File sequences appear in the Bank browser.

Using The Browser

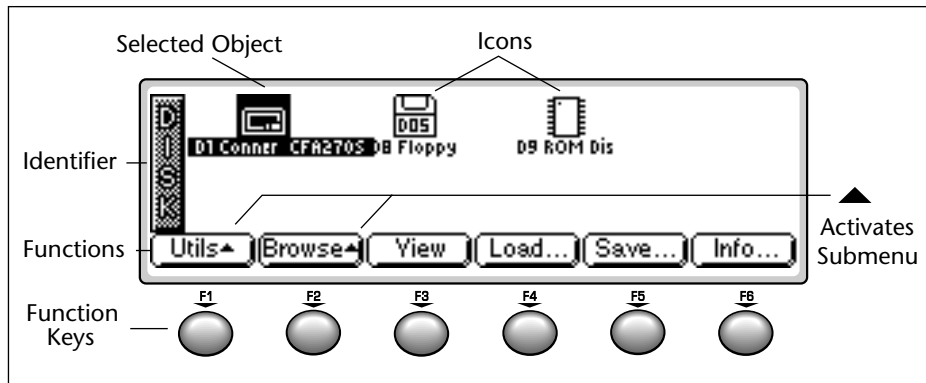

 The *Info...* button gives information about the selected object.

The type of *View* you choose (list or icon) is remembered for each level.

The Disk Browser makes it easy to navigate through the different levels of the disk drives. Take the time to familiarize yourself with this section because the Browser is an integral part of the system. A brief recap of the disk hierarchy is as follows:

- **Disk Drive** - Floppy disk drives, hard disk drives (internal and external), CD-ROM drives, optical drives, etc.
- **Folder** - Used to group and organize collections of banks.
- **Bank** - A group of presets which can be loaded into memory.
- **Preset** - A complete sound: samples, voices and all programmable options.
- **Sample** - An individual digital recording with looping information.
- **Sequence** - A recording of keyboard key depressions (with velocity and pressure) and any other performance controllers (pitch and mod wheels, real time control sliders, thumb button, footpedal, foot switch and program changes). Sequences can be stored along with the bank or can be exported as separate entities which appear as icons in the bank browser.

To Browse the Disk:

1. Press the **Disk** button. The LED illuminates and a screen similar to the one shown below appears.

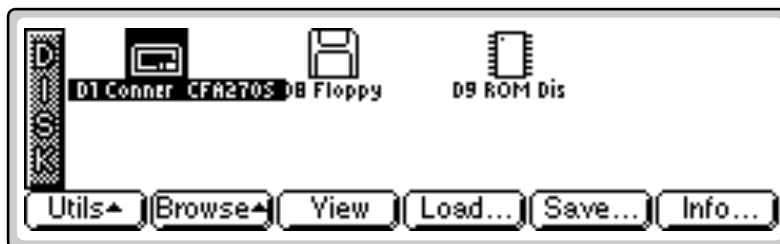

2. Press the **View** function key (F3). The display now changes to a list format. Press the View button again to return to the icon display.
3. Press the **Info...** function key (F6). A pop-up window appears with information about the hard disk drive. The other functions on this page such as "Drive Sleep" and "Drive Lock/Unlock" are covered in chapter 9 - Disk Menu.

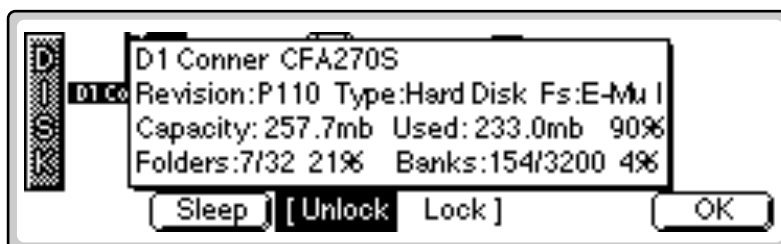

4. Press the **OK** function key to return.
5. Press the function key under **Browse** (F2). A second row of function keys appears.

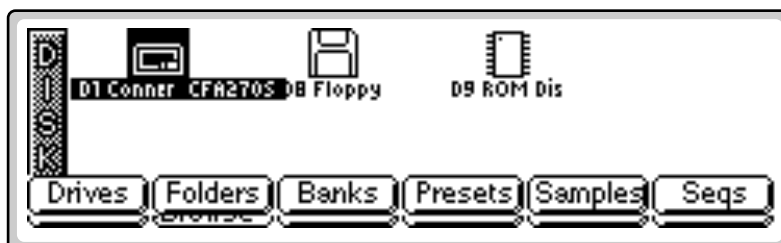

6. Press the function key under **Folders** (F2). The folders on the hard disk are displayed.

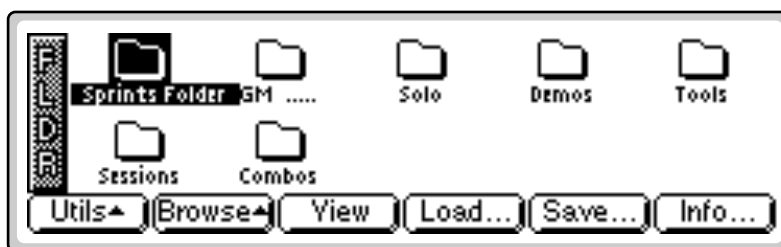

7. **Select a folder.** Use the cursor buttons, INC/DEC buttons or the Data Entry Control to select the active object.
8. Press the function key under **Browse**. Press the function key under Banks to examine the banks in the selected folder.

 If another page of choices exists, the Right Page arrow LED will be illuminated.

1 - The Basics

Selecting

 Sequences saved as Standard MIDI Files also appear as banks in the Bank browser.

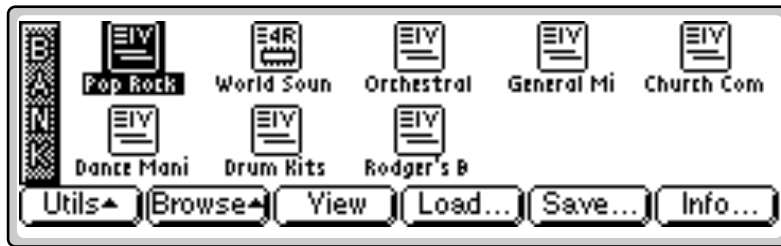

9. Choose a **Bank**.
10. Press the function key under **Browse** again.
11. Press the function key under **Presets** and the Preset screen shown below appears.

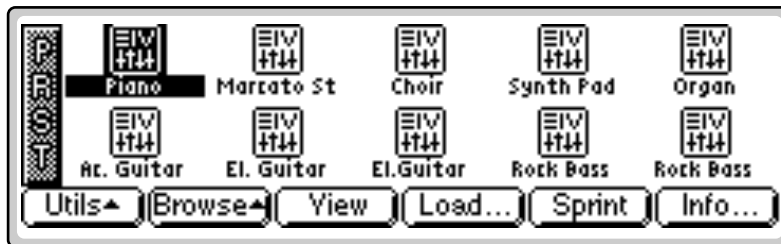

12. Choose one of the **Presets**, then press the function key under **Browse** yet again.
13. Press the function key under **Samples** to examine the samples used in the selected bank.

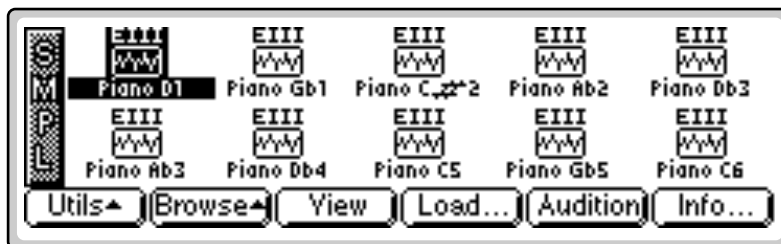

14. Press the **Info...** function key (F6). a pop-up window appears with information about the sample. Press **OK** to return to the previous view.

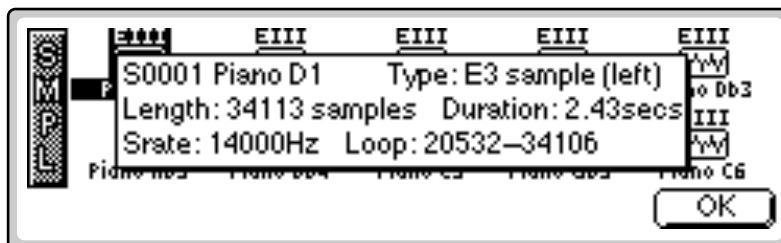

 The **Enter** button can be used to step forward through the Folder, Bank, Preset and Sample browsers.

Use the **Exit** button to back out of the pages.

15. Press the **Exit** button to “back out” of the pages. Press the **Exit** button once from the sample browser to return to the preset browser. Press **Exit** again to put you in the folder browser. Press it once more and you're in the disk browser. Press **Exit** one more time and you're out of the disk module altogether and back in the preset selection screen.
16. Press the function key under **Browse**.
17. Press the function key under **Seqs** to examine or load the sequences resident in the selected bank. If no sequences exist, a pop-up window will inform you of this fact.



Guided Tours

These Guided Tours will help get you up and running in no time.

Banks, Sequences, Presets & Samples

The Bank is a set of up to 1000 presets which can be loaded into and saved to disk from internal memory (RAM). When you save to disk, that collection of presets, samples and sequences is a bank. Banks can be constructed as large as the memory in your Emulator will allow (usually 128 MB). A preset is one complete keyboard setup containing voices and samples arranged on the keyboard together with all programmable synthesizer parameters. A sample is the most basic sound element of EOS and consists of the digitized sound together with truncation and looping parameters.

Banks, Presets and Samples can be loaded into RAM, renamed, saved to disk, and deleted using the Utilities menu of the individual modules.

The following sections describe how to Load, Save, Find, Name and Erase Banks, Presets and Samples. Also included in this section is how to change the way the display looks, how to load Standard MIDI Files and using the Assignable Keys.

A bank can be loaded directly from the Disk Browser or from the Main Screen. Presets and samples are loaded from the Preset Browser and Sample Browser respectively. Detailed instructions on how to access each of these browsers is located in the previous section titled “Using the Browser.” For simplicity’s sake, we’ll assume you are starting from the desired browser in the following instructions.

To Load Banks, Sequences, Samples, and Presets:

1. From the Browser, press the **Load** function key (F4). One of the load screens will appear. (If the bank is empty and you are loading a bank, the bank will load without delay.)
2. **Choose the item** you want to load using the Data Entry Control, INC/DEC buttons, cursor buttons or the numeric keypad.
3. Press **OK** to load the item or **Cancel** to cancel the operation.

If you are loading a bank and there is a bank already loaded, the Merge button appears. Merge combines the new bank with the bank previously loaded.

To Merge Banks:

4. Press the **Merge** function key to combine the two banks of presets or press **OK** to overwrite the current bank. The display will warn you if there isn't enough memory to hold both banks.

Note: EIII presets are translated into EOS presets as they are loaded. EOS voices are much larger than EIII voices. By contrast, EOS sample zones within voices are tiny. At import/load time, EOS tries to collapse adjacent EIII voices into EOS voice+sample zones if it can (Envs, LFOs, etc. must be the same), otherwise, it creates voices. Therefore, EIII presets that use lots of differing voices really balloon in EOS. Simpler presets (Instrument-based presets which have the same settings for all samples) may collapse into a single voice.

Loading a Bank Automatically

This function automatically loads the selected bank whenever the unit is first powered up.

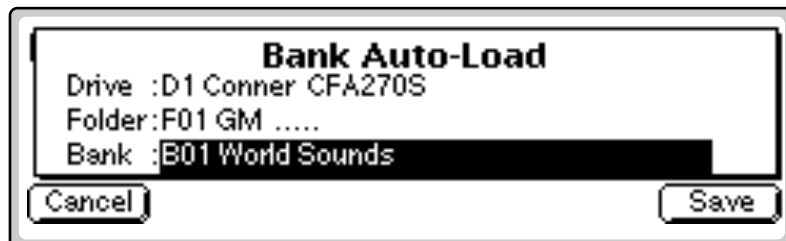

To Set the Auto Load Bank:

1. Press the **Master** button. The LED illuminates and the Memory Statistics screen appears.
2. Press the **Bank** function key (F2). A second row of function keys appears.

3. Press the **Auto...** function key (F3). The pop-up dialog box shown above appears.
4. **Select the bank** to be automatically loaded on power up. Banks can be selected using the numeric keypad, Data Entry Control, INC/DEC buttons and cursor buttons.
5. Press **Save** to confirm your choice or **Cancel** to cancel the operation.

Loading a Sequence from a Different Bank

An individual sequence can be loaded from another bank using the sequence browser. Simply load in the desired sequences, then save the bank to disk. Sequences can be either Emulator sequences or Standard MIDI Files.



To Load a Sequence from Another Bank:

1. **Select the Drive and Bank** containing the sequence you wish to load using the cursor buttons, INC/DEC buttons or the Data Entry Control from the Disk Browser.
2. **Select the Sequence** you wish to load from the Sequence Browser.
3. Press the **Load** function key (F4). A pop-up window prompts you to select the destination sequence.
4. **Choose a location** for the sequence using the Data Entry Control, the INC/DEC buttons or the numeric keypad. You may overwrite an existing sequence or choose an empty sequence as the destination. There are 50 possible sequence locations (and 50 Flash locations).
5. **Press OK** to load the selected sequence or **Cancel** to cancel the operation.
 - If you are loading an imported sequence from the bank browser, press **Merge** to combine it with the bank of presets in memory.

 *Important Information for Loading Standard MIDI Files*

* Use PC DOS formatted, high-density diskettes to load from floppy. Disks can be formatted on either the Mac or PC.

* To be readable by EOS, the file MUST have 0-8 characters, then a period, then "MID".

Loading Standard MIDI Files

The Emulator can load and play Standard MIDI File sequences (type 0 or 1). Sequence files should conform to PC DOS format using a DOS formatted disk and using the following format for the file name: 12345678.MID (up to eight characters followed by ".MID"). It is important to note that Standard MIDI Files appear as Banks, NOT as sequences in the sequence browser.



To Load a Standard MIDI File from Floppy Disk:

1. Insert a DOS formatted floppy disk containing the Standard MIDI Files.
2. From the Disk Browser, select the floppy drive.
3. Press **Browse**.
4. **Select Banks**. The MIDI sequences appears as banks.
5. Press the **Load** function key (F4). A pop up dialog box appears warning you that loading will destroy the resident bank.
6. Press the **Merge** button (F4). The selected sequence will be merged into the current bank, and will be placed in the first empty sequence location.
7. Press **OK** to load the selected sequence or **Cancel** to cancel the operation.

Saving Banks

A bank can be saved to disk from the bank browser.

To Save a Bank:

1. From the Browser, press the **Save** function key (F5). The following screen appears:

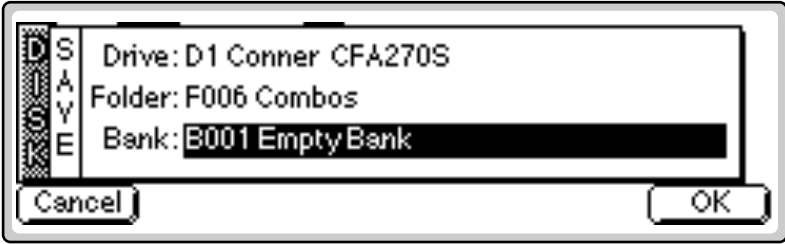

2. **Choose a location** for the bank using the Data Entry Control, the INC/DEC buttons, cursor buttons or the numeric keypad.
3. Press **OK** to load the bank or **Cancel** to cancel the operation. If you pressed "OK" the bank will be saved and the main preset selection screen appears. If you are about to overwrite an existing bank, the display will warn you.
 - If the bank contains SoundSprint presets (presets in locations 990-999), the display will ask you if you want to save the SoundSprint presets along with the bank.

Finding Banks, Presets, Samples & Sequences

This utility searches your disk library for a particular pattern of letters and numbers (a search string). If it finds the string anywhere in the name, the bank will be selected. Use the Find utility again to find additional matching items.

☞ To Find a Bank:

1. From the Bank Browser, press the **Utilities** function key (F1).
2. Press the **Find** function key (F6). A screen similar to the following appears.

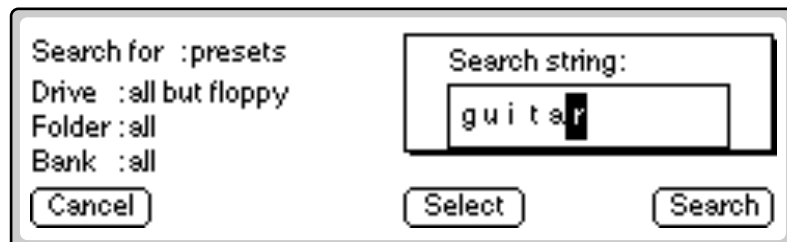

3. **Select the type of item** (folder, bank, preset, sample or sequence) you want to search for. If you have an idea of where the item is located, you can narrow the search by inputting additional data about the drive, folder or bank. Selecting "All" tells EOS to search everything.
4. Press the **String** function key (F4), and **enter the search string**. Letters can be selected using the numeric pad, Data Entry Control, INC/DEC buttons and cursor buttons, or using an ASCII keyboard.
5. Press the **Search** function key (F6) to search for the item or the **Cancel** function key (F1) to cancel the operation.

Naming Banks

Use this utility to rename a bank.

To Name a Bank:

1. From the Bank Browser, **select the bank** you wish to rename using the cursor buttons, INC/DEC buttons or the Data Entry Control.
2. Press the **Utilities** function key (F1).
3. Press the **Name** function key (F4). A pop-up window appears prompting you to name the bank.
4. **Change the name** of the bank. Select letters using the numeric pad, Data Entry Control, INC/DEC buttons, cursor buttons, or using an ASCII keyboard.
5. Press the **OK** function key (F6) to confirm the new name or the **Cancel** function key (F1) to cancel the operation.

Erasing Banks

This utility allows you to erase an entire bank.

To Erase a Bank:

1. From the Bank Browser, **select the bank** you wish to delete using the cursor buttons, INC/DEC buttons or the Data Entry Control.
2. Press the **Utilities** function key (F1).
3. Press the **Delete** function key (F3). A pop-up window appears asking you if you want to delete the bank.
4. Press the **OK** function key (F6) to delete the bank or the **Cancel** function key (F1) to cancel the operation.

Assignable Keys

You can program six assignable keys on the front panel to jump to almost any screen in EOS. This handy feature saves you from having to page through multiple menus to find the screen you want to edit. The assignable keys can be programmed from the assignable keys screen in the Master Utilities submodule or, directly from any screen in which you are working.

To Program an Assignable Key from the Master Menu:

1. Press the **Master** button. The LED illuminates and the Memory Statistics screen appears.
2. Press the **Utilities** function key (F1). A second row of function keys appears.
3. Press the **AsnKy** function key (F1). The following screen appears.

 *The Assignable Keys have secondary functions which are accessed by holding down the decimal point button and pressing the Assignable Key.*



4. **Select a screen.** Use the Data Entry Control or the INC/DEC buttons to change the screen associated with each assignable key.
5. Press **Save** to store the assignable keys settings and return to the Memory Statistics screen. Press **Cancel** to cancel the operation and return to the Memory Statistics screen.

To Program an Assignable Key from the Current Screen:

This method allows you to link an assignable key to the screen you are currently viewing.

- **Press and hold one of the assignable keys** from any screen. After two seconds a pop up window appears, informing you that the assignable key has been programmed for the current screen.

 **Note:** if a key is assigned to RAM/ROM, it can't be programmed from the current screen

Recording a Sequence

The easiest way to learn about sequencing is simply to record one. A multi-timbral sequence contains more than one sound. In this guided tour of the sequencer, you'll learn how to set up the metronome, the input quantize function and lay down multitimbral tracks. These instructions apply to both a rack and keyboard EOS synthesizers. If you're using a Rack Emulator, make sure your MIDI keyboard is connected. If you have two MIDI In ports, use **Port A**.

Load a Bank of Sounds

For your initial investigations, choose a bank which contains all types of instruments, including drums. The *Combos* Bank might be a good choice.

1. From the main screen press the **Load** function key (F4).
2. Select the desired **Folder** and **Bank**.
3. Press the **Load** function key (F6).
4. The display informs you that you are about to overwrite the current bank. Press **OK** (F6) to load the bank.

Select Multimode

5. From the main screen press the **Mode** function key (F6).
6. Select **Multi** (F6). The following screen should appear.

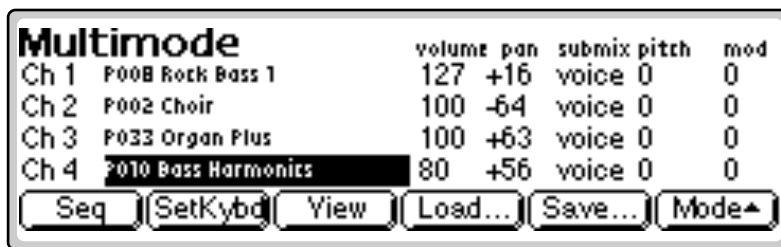

- There are two different Multimode screen views. If you get the other screen, press the F6 function key, then press **View** (F3).

Enter the Sequencer Submodule

7. Hold the **Decimal Point** button and press **Assignable Key 1**. The **Sequence Manage** screen appears.
8. Press the **Edit** function key (F5). The **Edit** screen appears.

Set up the Metronome

The **Metronome** is important if you want to use the **Quantize** functions. If you don't want quantization and just want to enter a few tracks, skip to step 20.

9. Press the **Setup** button (F3). A second row of function keys appears.
10. Press the **Metro** button (F1). The following screen appears.

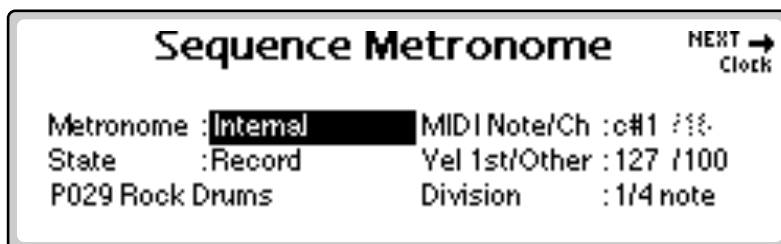

11. Set the **Metronome** parameters as shown.
12. The lower left field allows you to select a preset to be used for the **Metronome**. Select a **preset** containing a click or short percussion sound.
13. Move the cursor to the **MIDI Note/Ch** field.
14. Select the **metronome sound** using the **Data Entry Control**, **INC/DEC** buttons or the keyboard. The metronome sound is played as you scroll through the note numbers.
15. Press the **Exit** button to leave the **Metronome** screen.

☞ Turn Quantization On

Input Quantization is really handy for laying down a drum track for your sequence.

16. Press the **Setup** function key (F3) again. A second row of function keys appears.
17. Press the **Input** function key (F3). The following screen appears.

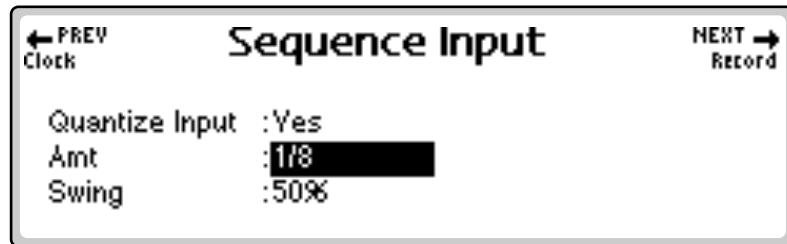

18. **Turn Quantize Input On** (Select Yes). Set Swing to 50%. Set the Amount for quarter notes or eighth notes for starters.
19. Press the **Exit** button to lock in your selections and return to the Edit screen.



☞ Setup Track 1 for Recording

OK! You're almost ready to start recording.

20. Set the **Track Mode to Record**. Move the cursor to the Track Mode location as shown above. Set this field to **R** (Record) using the Increment button or Data Entry Control.
21. Move the cursor right to the Channel field. **Set the channel to @1** using the Inc/Dec buttons or Data Entry Control. The @1 function records on MIDI channel 1 exclusively.
22. **Select a preset**. Move the cursor left to the Preset field. **Play the keyboard and select the preset** you want to play on your first track. Select a drum preset if you're laying down a drum track.

☞ Record Track 1

23. Press the **Menu/Transport** function key (F6). The Transport control buttons appear on the lower line of the display.
24. Get ready to record! Press the **Record** function key (F4).
25. Press the **Play** function key (F3) to begin recording. You should be hearing the metronome.
26. **Start playing.** If you make a serious mistake in your playing and want to try again, press **Abort** (F5). Then press **Record**, then **Play** to begin again.
27. Press the **Stop** function key (F2) to end recording. Press **RTZ** (F1) to rewind to the beginning of the sequence. Press **Play** (F3) to play back your creation.
 - Note that the Track Status field for Track 1 now reads P for playback. The track can also be set to **M** to Mute the track if you don't want to hear it.

☞ Record Another Track

28. **Set Track 2 to Record.** Move the cursor to the record field of track 2 and set the track to R (record).
29. Move the cursor to the channel field of track 2 and **set the channel to @2.** This will force all information onto MIDI channel 2.
30. Move the cursor back to the preset field on track 2 and **select a preset.**
31. You're ready to record track 2. Follow the instructions for recording on track 1 and GO!

Arpeggiator Sequencing!

One of the many things you can do with EOS is combine the Arpeggiator and the Sequencer. This is a great idea stimulator and tons of fun.

☞ Load a Bank of Sounds (*E-Synth - jump to step 5*)

1. From the main screen press the **Load** function key (F4).
2. **Select the desired Folder and Bank.**
3. Press the **Load** function key (F6).
4. The display informs you that you are about to overwrite the current bank. Press **OK** (F6) to load the bank.

☞ Select Multimode

5. From the main screen press the **Mode** function key (F6).
6. Select **Multi** (F6). The following screen appears.

 There are two different Multimode screen views. If you get the other screen, press the key (F6), then press View (F3).

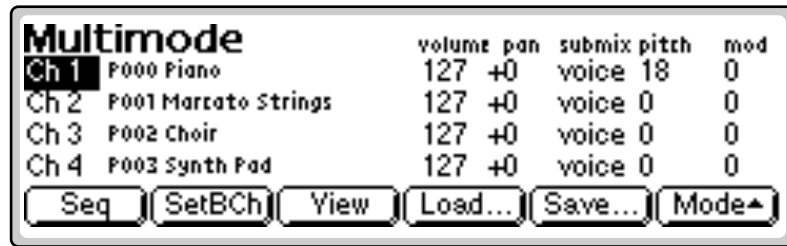

Set Keyboard to Channel 1

7. If you are using an E-Synth keyboard or an E4K, select **channel 1** and press **SetBCh** (Set Basic Channel). If you are using an external MIDI keyboard, set it to transmit on channel 1.

Select a Preset

8. Move the cursor to the preset field and **select a preset**. Turn on the Arpeggiator.
9. Press the **Mode** function key (F6).
10. Select **Arp** (F5). The Multimode Arpeggiator screen appears.
11. The Arpeggiator will be on. While playing the keyboard **select a Preset** using the Data Entry Control, INC/DEC buttons or the numeric keypad.



12. Adjust the **Arpeggiator** controls until you have a nice groove going.

Enter the Sequencer Submodule

13. Press the **Seq** function key (F1) from the main preset screen. The Sequence Manage screen appears.
14. Press the **Edit** function key (F5). The Edit screen appears.

 E-Synth Keyboard and E4K have dedicated Sequencer buttons.





Since you've already selected a preset for MIDI channel 1 in Multimode, the preset will automatically come up when you set @1 as the channel number.

Setup Track 1 for Recording

Almost ready to start recording...

15. Set the **Track Mode** to **Record**. Move the cursor to the Track Mode location as shown above. Set this field to **R** (Record) using the Increment button or Data Entry Control.
16. Move the cursor right to the Channel field. Set the **channel** to **@1** using the Inc/Dec buttons or Data Entry Control. The @1 function records on MIDI channel 1 exclusively.
17. **Play the keyboard**. You should be hearing the arpeggiator playing the preset you selected.

Record Track 1

18. Press the **Menu/Transport** function key (F6). The Transport control keys appear on the lower line of the display.
19. Get ready to record! Press **Record** (F4), then **Play** (F3) to begin recording.
20. **Start playing**.
21. Press **Stop** (F2) to end recording. Press **RTZ** (F1) to rewind to the beginning of the sequence. Press **Play** (F3) to play back your creation.

Turn the Arpeggiator Off

22. Note that the arpeggiated sequence is being arpeggiated again! Press the **Stop** function key (F2), then press the **Exit** button to return to the Multimode screen.
23. Press the **Mode** function key (F6).
24. Select **Arp** (F5). The Multimode Arpeggiator screen appears.
25. Press **Stop** (F2) to stop the arpeggiator.
26. Press **OK** (F6) or **Done** (F1) to return to the Multimode screen.

Back to the Sequencer...

27. **Hold the Decimal Point** button and press **Assignable Key 1**. The Sequence Manage screen appears.
28. Press the **Menu/Transport** function key (F6). The Transport control keys appear on the lower line of the display.
29. Press **Play** (F3) to play the sequence. Yeah!

Record More Tracks?

30. **Repeat steps 15-21** changing the MIDI channel for each subsequent track.

You can also record additional tracks using the arpeggiator. To do this you must match the MIDI channel generated by the keyboard to the MIDI channel of the track you wish to record. Use Set Kybd on E-Synth or E4K. If you are using an external MIDI keyboard, change the MIDI channel output from the keyboard to the same channel you are recording on the track.

A Practice Sampling Session

Sampling lets you play ANY SOUND! In this session, you will sample your own voice. Although there is much more to the art of sampling than just sampling your voice, this lesson will give you a good start.

In preparation for this sampling session, please read over Chapter 5, Sample Management.

☞ Connections...

1. Connect a microphone to the left sample input jack on the rear panel of your EOS instrument. If you don't have a microphone you can use another signal source such as a CD player. Connect a CD player to both the left and right sample inputs or just the left input if you want to sample in mono.

☞ Erase the Bank

This step “cleans the slate” for your experiments.

2. Press the **Master** button to enter the Master module.
3. Press the **Bank** function key (F2).
4. Press **Erase** (F1). A popup dialog box appears asking you if you want to erase Preset, Samples and Sequences.
5. Don't worry, be happy! Press **OK** (F6).

☞ Sample Setup

6. Press the **Sample Manage** button.
7. Press the **New** function key (F3). The following screen appears.

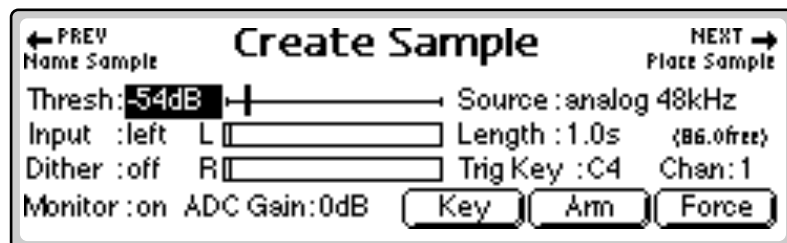

8. If you are sampling in mono, select the Left channel only. The Threshold sample trigger only reads the Left channel.

1 - The Basics
A Practice Sampling Session

 **Ultra Users:** To select the 48kHz (or 24kHz) sampling rate, you must change the "Default Clock" located in the MASTER menu under "In/Out" to 48kHz.

- Set the **Source** to analog 48 kHz or analog 44.1 kHz.

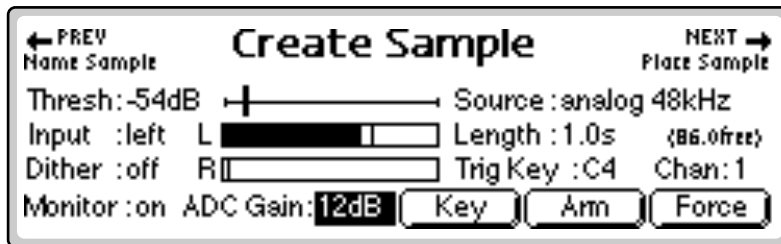

- Set **Length** to 2 seconds.
- Move the cursor to **ADC Gain**.
- Sing "Ahhh"** into the microphone. (This is an easy sound to loop.) You should see the VU meter moving.
- Still singing "Ahhh", adjust the **ADC Gain** using the Data Entry Control or INC/DEC buttons so that the peak bar of the VU meter comes close to the extreme right side without actually reaching it.
- Set the **Threshold** to -54 dB. When the input sound exceeds this level, sampling will start.

 **Sampling!**

- Press the **Arm** function key (F5). This arms the sampling process.
- Sing Ahhhh!** The display says "Sampling".
- When you are out of breath, press **Stop** (F1), Exit or Enter to stop sampling. In any case, EOS will stop sampling after 2 seconds. The following screen appears.



- The screen shown above gives you the option to Dispose, Keep or place the sample you just took. It also contains the Automatic Sampling parameters. Set the **Automatic Truncate, Normalize and Loop** parameters as shown above (both, relative, off).
- Press the **Place** function key (F6).
- Popup dialog boxes will inform you that the sample is being Truncated and Normalized. **Play the keyboard.** Your voice will play up and down

 *Truncation trims the silence off the beginning and end of the sample.*

Normalize boosts the signal to its optimum level.

the entire keyboard. You will probably notice that the original key sounds the most natural.

Congratulations! You've just taken your first sample. If you haven't already done so, check out Chapter 5, Sample Management to learn all about the various sampling options.

Name the Sample

Name everything! It saves valuable time when you're trying to find a certain Sample or Preset you created earlier.

 **Tip:** If you name the current preset *BEFORE* taking the sample, EOS will automatically name the sample for you. If you happen to be sampling another synthesizer and have MIDI connected, EOS will even add the original key to the sample name!

21. Press the **Exit** button to go to the main Sample Manage screen.
22. Press the **Name** function key (F2). The following screen appears.

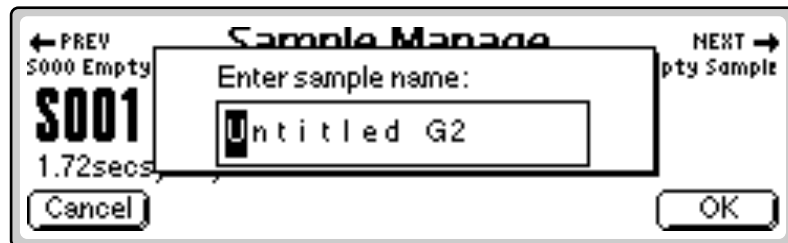

23. **Change letters** using the Data Entry Control, INC/DEC buttons or numeric keypad. Move the cursor using the left/right cursor buttons. The up cursor adds a space. The down cursor button deletes a space.
24. Press **OK** (F6) when you're finished naming your sample.

Looping

Looping has gained a reputation for being something of a black art. In actuality, it's really not that difficult to loop most sounds, especially with all the looping tools provided by EOS. Let's go ahead and loop the sample you just created.

25. Press the **Sample Edit** button.
26. Press the **Tools1** key (F3). Another row of function keys appears.
27. Press **Loop** (F1). The following screen appears.

 The Attack portion of the sound is the large part of the waveform. The attack contains changing harmonics and is difficult to loop. Move the loop start and end points into a portion of the wave where the level looks steady.

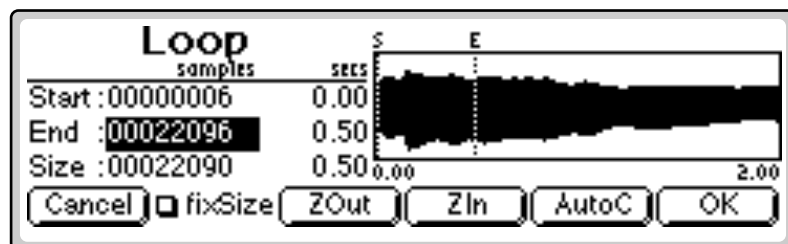

28. Turn the “**fixSize**” parameter **Off** by pressing the F2 key so there is no check mark in the box.
29. Move the cursor down to the third line and **adjust the Loop Size** so that it is about half a second or less. As you do so, you'll see the dotted line marked “E” move toward the left.
30. **Play a key.** You'll hear your voice being looped... badly.
31. Move the cursor back up to the Start field. **Play a key as you adjust the Loop Start** using the Data Entry Control. As you move the start point out of the “attack” portion of the sound, you'll notice the loop improve. Find a location where the loop sounds best. Don't worry if it's not that great.
32. Press the **AutoC** function key (F5 Autocorrelate). This advanced control examines the waveform for similarities and adjusts the loop points for you.
33. **Play a key.** Did the loop improve? If the volume wavers excessively, try reducing the loop start. Autocorrelate again.
34. **Continue adjusting** the loop size and start times. Autocorrelate the sample after each adjustment until you get a good loop. It takes a little practice, but you'll get it.
35. **Press OK** when you've found a good loop. The Loop Parameters screen appears. This screen contains three other looping tools. Press **OK** to continue.
 - Read about the other looping tools in Chapter 5, Sample Edit and, by all means, feel free to try them out. The best way to learn about looping is to experiment with a wide variety of signals.

Exploring the Preset

The Preset Edit module is where everything comes together into a complete keyboard setup. It's a huge module and can be initially confusing. The first thing you need to know is that there are two main levels to the Preset Edit module.

Preset Definition is used for arranging voices and samples on the keyboard, editing global preset parameters and linking presets, as well as setting effects and initial controller values.

Dynamic Processing is the lower level which is used to perform more detailed editing of voices such as envelope shaping of the amplifier and filter as well as the modulation parameters. This is the “synthesizer” section of EOS.

 Use the **EXIT** button to back out of the Preset Edit module if you get lost.

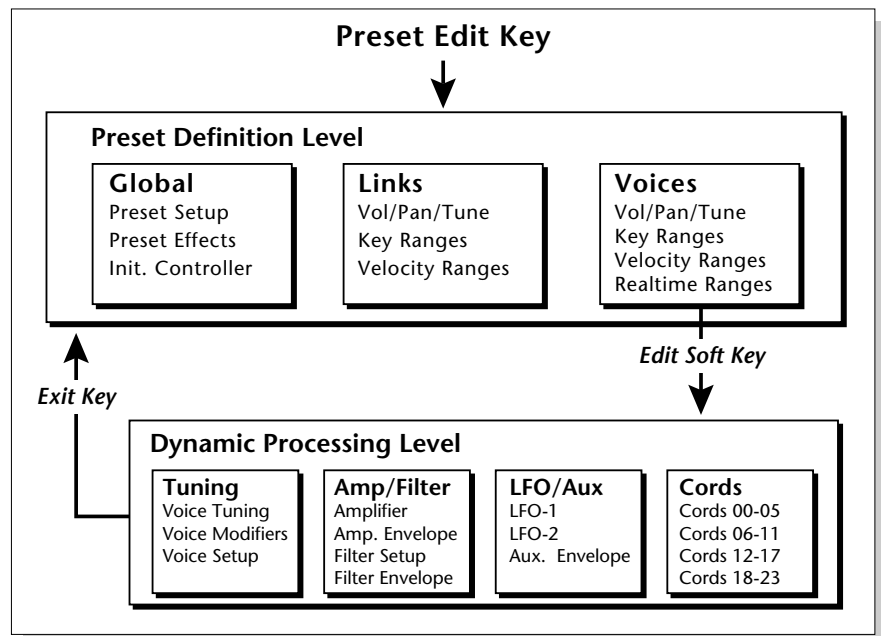

The Preset Definition layer contains three main pages.

Global Editor. Preset Transpose, Volume and Preset Effects.

Links. Create stacked preset layers or splits.

Voice Editor. Allows you place voices and samples on the keyboard and crossfade or switch between them according to key position, velocity range and realtime controls. Also contains voice tuning, volume and pan controls.

The **Dynamic Processing** parameters are accessed by pressing the Edit button while in one of the Preset Edit, Voice screen parameters.

Which Voices are Assigned to the Keyboard?

Good question. You'll often want to know how samples and voices are assigned in existing presets or you may want to build your own presets.

1. Select a preset to examine.
2. Press the **Preset Edit** button. The following screen appears.

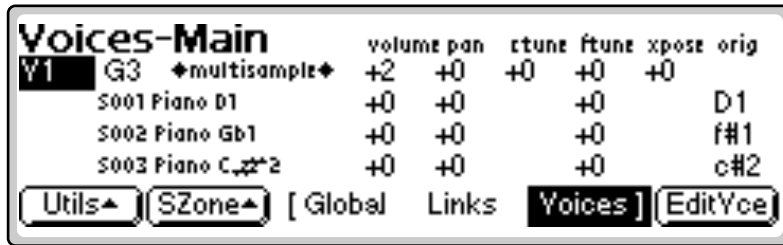

In this preset, Voice 1 is a multisample. The samples contained in the multisample are listed below it. The volume, pan position, coarse and fine tuning, transpose and original keys can be adjusted from this screen.

3. Press the **Next Page** button. The arrow next to it is illuminated, indicating that there is another page of information. The **Key Window** appears.

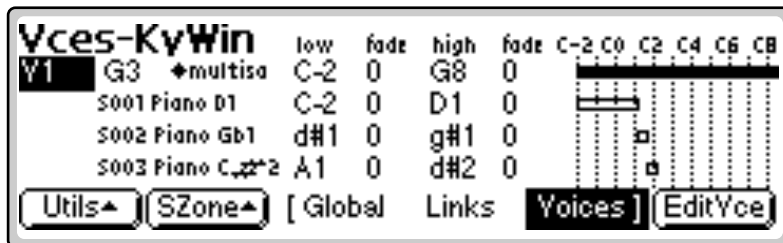

The keyboard assignments of the multisample and the samples it contains are shown graphically.

Press the **Down cursor** button repeatedly to view the keyboard assignment of the other voices.

4. Press the **Next Page** button to go to the **Velocity Window**. The velocity window allows you to switch or fade samples and voices according to key velocity.

See "Velocity Window Controls" on page 300 for detailed information about the Velocity Window.

5. Press the **Next Page** button again to go to the **Realtime Window**. The realtime window allows you to switch or fade samples and voices according to a realtime control such as a modulation wheel or an LFO.

See "Realtime Window Controls" on page 319 for detailed information about the Realtime Window.

Creating a Link

Linking presets is a quick and easy way to create huge stacked presets, split keyboard presets and create new sounds.

1. Press the **Links** function key (F4). The preset link page appears. The screen should appear as below with “No Links in Preset”. If not, choose another preset and return to Preset Links.



2. Press the **Utils** function key (F1). Another row of function keys appears.
3. Press **New...** (F1). The following screen appears.

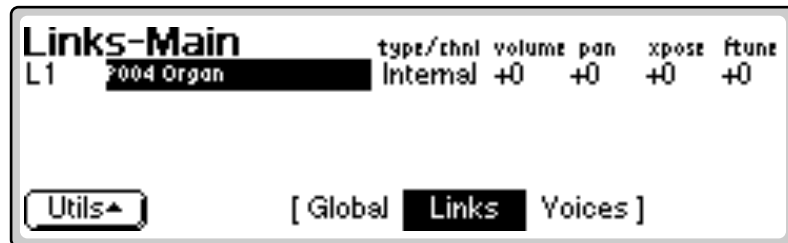

4. Move the cursor to the preset field and **select a preset** using the Data Entry Control, INC/DEC buttons, or the numeric keypad.
5. **Play the keyboard.** Both presets will be heard.

Add another link if you want. Also, be sure to check out all the other link options. See “Preset Edit - Links” on page 291.

1 - The Basics

Master Menu

2

2 - Master Menu

Overview

The Master Module commands affect the Emulator on a global basis (*all presets*). Master operations affect overall tuning, LCD contrast and Master Effects to name a few. All of the settings defined in the Master Menu (with the exception of a few of the Sequencer settings) are saved into Flash RAM when you exit the module, meaning the settings are stored even when you turn off the unit.

This chapter describes the global settings, features and commands you can carry out using the Master Menu. The sections in this chapter are organized by submenu as they appear in the Master Menu.

The Master Menu contains six main submenus:

Utilities. Controls for the assignable keys, test tones and volume control recalibration. Also contains the channel status indicator, credits and software version display.

Bank. Allows you to name or erase the bank and set a bank to be auto-loaded on power-up. If you have Flash RAM or Flash ROM installed, the Bank submenu contains the Flash Utilities also.

Setup. Contains six submenus: Tune, Input/Output, Miscellaneous, SCSI, Import and Memory Configuration.

FX. Contains the digital effect processor functions.

Sequence Manage. Contains a 48-track sequencer.

MIDI. Contains global MIDI controls, velocity curve and other miscellaneous MIDI functions.

Memory Statistics

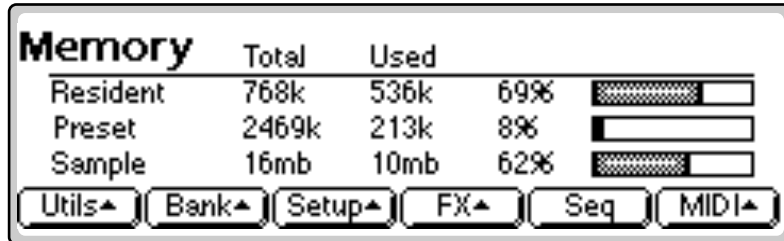

 The E-6400, e-64, E4K and EIV contain about half a Mbyte of usable Preset Memory. The E4X and E-Synth contain about 2.6 Mbytes of usable Preset Memory. Ultra series machines contain about 4 MB of usable preset memory. Contact your E-mu dealer for upgrade information.

The main screen shows the internal memory status. There are three kinds of memory — Resident Memory, Preset Memory & Sample Memory.

The Resident memory display shows the amount of preset memory available for the optional (*except on E-Synth*) ROM or Flash RAM banks. Preset memory (also called CPU memory) is used to hold both preset parameter information and sequences. (The ratio between presets & sequences is user adjustable.) Sample memory, which contains the actual sample data, can vary from 4 megabytes to 128 megabytes.

Presets and sequences require far less memory than do samples, so less preset memory is needed. You are not likely to run out of preset memory, even when creating huge banks.

To View the Memory Statistics:

- Press the **Master** button on the Emulator. The Master Menu main screen appears showing the Memory Statistics.

Master Utilities

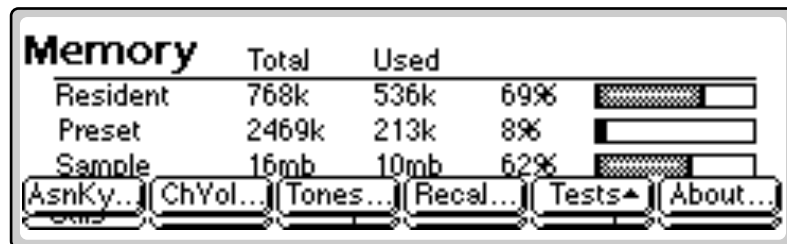

The Master Utilities menu contains several functions:

Assignable Keys (AsnKy). Allows you to program the three Assignable Keys on the front panel of the Emulator.

Channel Volume (ChVol). Displays a bar graph showing the current volume of all channels.

Reference Tones (Tones...). Generates accurate tones used to troubleshoot your audio system without having to load a bank.

Recalibration (Recal...). Recalibrate the front panel volume control, rotary encoder, and for the E4K and E-Synth Keyboard, the control wheels and pedal input.

Test Access (Tests). Provides access to the Service Center diagnostic routines.

About (About...). Displays the current software version, the current hardware configuration, and credits.

Assignable Keys

You can program the Assignable Keys on the front panel to call up almost any screen. This saves you from having to page through multiple menus to find the screen you want to edit.

Simply press an assignable key to call up its assigned location. Press and hold the **Set/Shift** (decimal point) key while pressing an **Assignable Key** to access three additional menu locations.

The assignable keys can be programmed from the assignable keys screen in the Master module or directly from any screen in which you are working.

To Program the Assignable Keys from the Master Menu:

1. Press the **Master** button. The LED illuminates and the Memory Statistics screen appears.
2. Press the **Utilities** function key (F1). A second row of function keys appears.
3. Press the **AsnKy** function key (F1). The following screen appears.

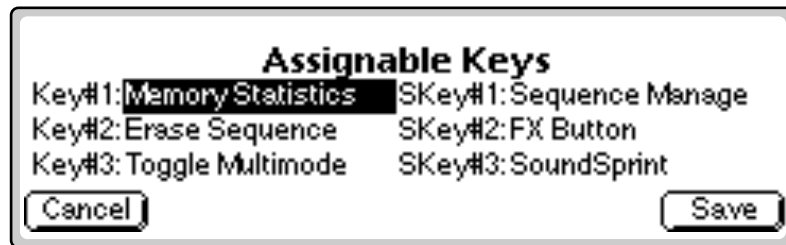

4. **Select the desired screen.** Use the Data Entry Control or the INC/DEC buttons to change the screen associated with each assignable key.
5. Press the **Save** function key (F6) to store the assignable keys settings and return to the Memory Statistics screen or press **Cancel** to cancel the operation and return to the Memory Statistics screen.

To Program an Assignable Key from the Current Screen:

This method allows you to link an assignable key to the screen you are currently viewing.

- **Press and hold one of the Assignable keys** from any screen. After two seconds a pop up window appears, informing you that the assignable key has been programmed for the current screen.

 The Assignable Keys have secondary functions which are accessed by holding down the decimal point button and pressing the Assignable Key.

Channel Volume

This function calls up a bar graph display showing the number of channels each sound uses and the volume of all voice channels. This channel status display is a useful indicator of your channel usage. Channels become available for reassignment when their output volume falls below a certain level.

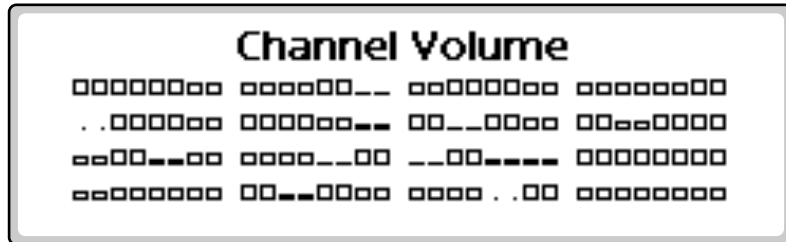

Tones

This function generates accurate reference tones which can be used to troubleshoot your audio system without loading a bank or can be used to test each audio output. The following frequencies can be selected: 50Hz, 100Hz, 200Hz, 261.60Hz, 440Hz, 444Hz, 500Hz, 1kHz, 2kHz, 5kHz, 10kHz, 15kHz, and 19kHz. Sine, Triangle, Square or Sawtooth waveforms can be selected. The master volume control has no effect on the volume of Tones.

To Enable the Reference Tone:

1. Press the **Master** button. The LED illuminates and the Memory Statistics screen appears.
2. Press the **Utilities** function key (F1). A second row of function keys appears.
3. Press the **Tones...** function key (F3). The following screen appears and the defined tone plays continuously through the selected outputs.

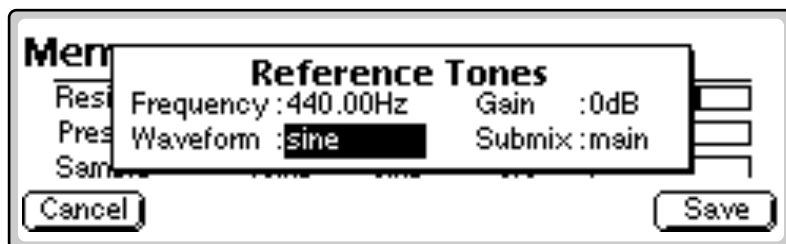

4. **Adjust the frequency, waveform, gain and output submix channel** using the Data Entry Control or INC/DEC buttons.
5. Press the **Save** function key (F6) to accept the changes. Press **Cancel** to return to the Memory Statistics screen.



ALWAYS recalibrate the Pitch and Modulation wheels of the E4K after installing new software or initializing the EEPROM.

Recalibration

This utility recalibrates the front panel volume control, Data Entry Control and, for the E4K, the control wheels. We recommend you recalibrate the controls periodically to adjust them for normal wear and tear or if the controls ever behave strangely.

You can press Cancel at any time during recalibration to skip that particular control and move on to the next.

To Recalibrate

1. Press the **Master** button. The LED illuminates and the Memory Statistics screen appears.
2. Press the **Utilities** function key (F1). A second row of function keys appears.
3. Press the **Recal...** function key (F4). The following screen appears.

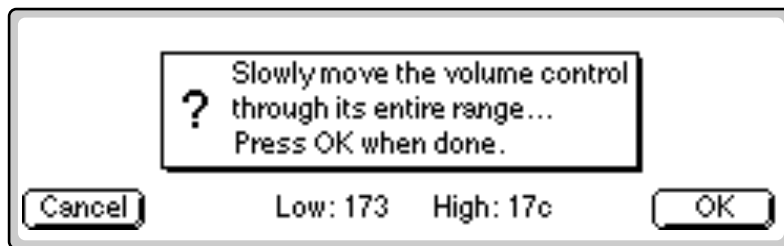

4. **Adjust the volume slider** to the minimum and maximum positions.
5. Press **OK**. The display will say, "Saving System" and the following recalibration screen appears.

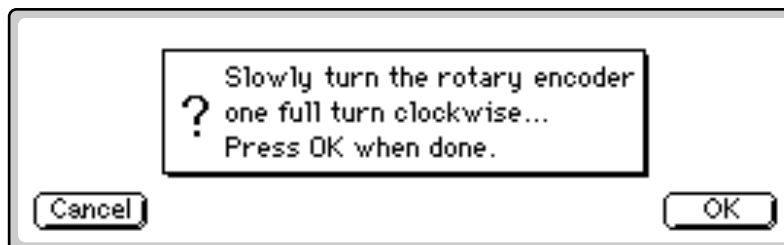

6. **Move the encoder** one revolution.
7. Press **OK**. Again, the display says, "Saving System."

If you have an E4K or E-Synth Keyboard, continue on with steps 8 through 10. These screens only appear if you have an E4K or E-Synth Keyboard.

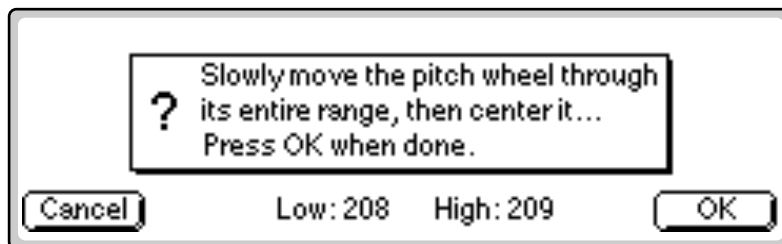

8. Move the pitch wheel as directed.
9. Press OK. The display will say, "Saving System" and the last recalibration screen appears.

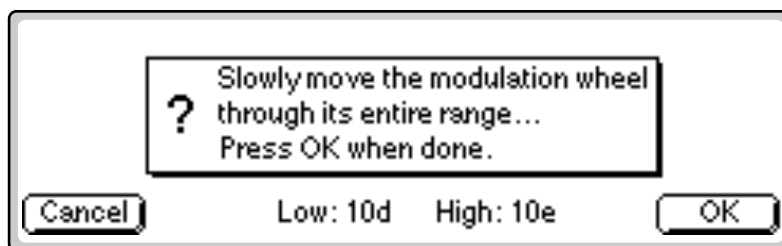

10. Move the mod wheel as directed, then press OK.

 The footpedal must be plugged in at boot time for EOS to recognize it.

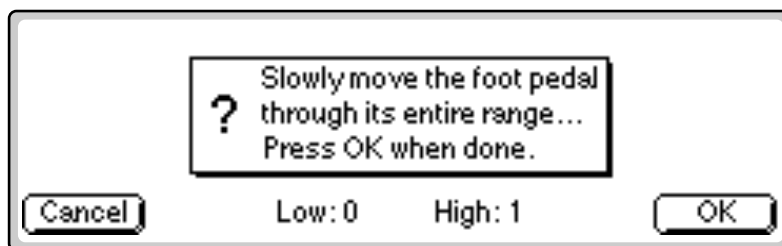

11. Move the foot pedal as directed, then press OK.

Test Access

This menu item provides access to the Service Center diagnostic routines.

Some of the diagnostic routines have the potential to destroy the data on your hard disk. It is for this reason that the diagnostics are protected from casual use by a secret password. If you read carefully through this manual, maybe you'll find it.

About...

The About screen displays the current software version and hardware configuration in the unit. It also credits the instrument designers and displays the E-mu Systems phone number to call for ordering additional sounds.



To Get Info About Your Instrument:

1. Press the **Master** button. The LED illuminates and the Memory Statistics screen appears.
2. Press the **Utilities** function key (F1). A second row of function keys appears.
3. Press the **About...** function key (F6). A pop-up dialog box lists the resident software version and a second row of function keys appears.
4. Press **Config** to show the hardware configuration.
5. Press **Sounds** to find out how to order sounds.
6. Press **Credits** to list the creators of your instrument.
7. Press **Exit** to return to the Memory Statistics screen.

Bank

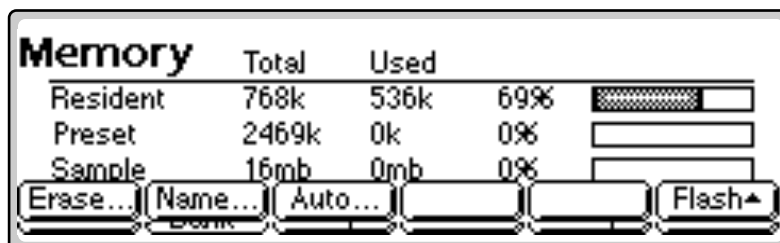

Memory	Total	Used	Percentage	Progress Bar
Resident	768k	536k	69%	<div style="width: 69%; background-color: #cccccc;"></div>
Preset	2469k	0k	0%	<div style="width: 0%; background-color: #cccccc;"></div>
Sample	16mb	0mb	0%	<div style="width: 0%; background-color: #cccccc;"></div>

Buttons: Erase... Name... Auto... Flash▲

The Bank submenu contains functions which allow you to name and erase the bank and automatically load a bank on power up. Flash Utilities are also accessed from this sub-menu if you have the Sound ROM or Flash Sound RAM upgrades installed.

Erase Bank

Erasing a bank erases ALL the memory in RAM including all samples, voices presets and sequences. Erasing the bank does not erase anything stored on your hard disk, only the contents of RAM.

To Erase the Bank:

1. Press the **Master** button. The LED illuminates and the Memory Statistics screen appears.
2. Press the **Bank** function key (F2). A second row of function keys appears.
3. Press the **Erase** function key (F1). A pop-up dialog box appears asking you if you want to erase all presets and samples.
4. Press **OK** to erase the bank or **Cancel** to cancel the operation.

Name Bank

This utility allows you to name the current bank.

To Name the Bank:

1. Press the **Master** button. The LED illuminates and the Memory Statistics screen appears.
2. Press the **Bank** function key (F2). A row of function keys appears.
3. Press the **Name...** function key (F2). A pop-up dialog box appears asking you to enter the new bank name.
4. **Name the bank.** Letters can be selected using the numeric keypad, Data Entry Control, INC/DEC buttons and cursor buttons, or using an ASCII keyboard.
5. Press **OK** to name the bank or **Cancel** to cancel the operation.

Auto Bank Load

This function automatically loads the selected bank whenever the unit is first powered up.

To Set the Auto Load Bank:

1. Press the **Master** button. The LED illuminates and the Memory Statistics screen appears.
2. Press the **Bank** function key (F2). A second row of function keys appears.
3. Press the **Auto** function key (F3). The pop-up dialog box appears similar to the following illustration.



4. **Select the bank** to be automatically loaded on power up. Banks can be selected using the numeric keypad, Data Entry Control, INC/DEC buttons and cursor buttons.
5. Press the **Save** function key (F6) to confirm your choice or **Cancel** to cancel the operation.

Flash Utilities

These special utilities are exclusively for use with Flash RAM. If you don't have Flash ROM or RAM installed in your Emulator, these options will not be available.

Preset RAM is used as the intermediary storage area when copying between Flash and disk. To copy presets from a floppy into Flash RAM, you first load them onto the bank, then use the Copy RAM→Flash utility to copy them into Flash RAM.

- **Clear Flash** - Erases all resident presets and sequences.
- **Compact Flash** - Defragments Flash RAM. As presets are erased and modified, the memory can become fragmented. This utility re-orders the memory in the most efficient way.
- **Copy RAM to Flash** - Copies RAM presets into Flash RAM.
- **Copy Flash to RAM** - Copies Flash presets to Preset RAM.

To Access the Flash Utilities:

1. Press the **Master** button. The LED illuminates and the Memory Statistics screen appears.
2. Press the **Bank** function key (F2). A second row of function keys appears.
3. Press the **Flash** function key (F6). Another row of function keys appears.
4. **Select the desired Flash utility** using function keys F1-F4. You will be asked to confirm the selected operation.
5. Press **OK** (F6) to confirm your choice or **Cancel** (F1) to cancel the operation.

To Copy Presets from Floppy to Flash:

1. **Insert the Disk** containing the presets into the floppy disk drive.
2. Press the **Load** function key (F4) on the main screen. The Load Preset screen appears.
3. Move the cursor up to the **Drive Select** field.
4. **Select the Floppy drive** using the Data Entry Control or INC/DEC buttons.
5. Press **LoadAll** (F6). The presets are loaded into RAM.
6. Press the **Master** button. The LED illuminates and the Memory Statistics screen appears.
7. Press the **Bank** function key (F2). A second row of function keys appears.
8. Press the **Flash** function key (F6). Another row of function keys appears.

2 - Master Menu Flash Utilities

 *Ultra units may contain up to 1000 flash presets.*

9. Press **RAM→Flash** (F3). The following screen appears.

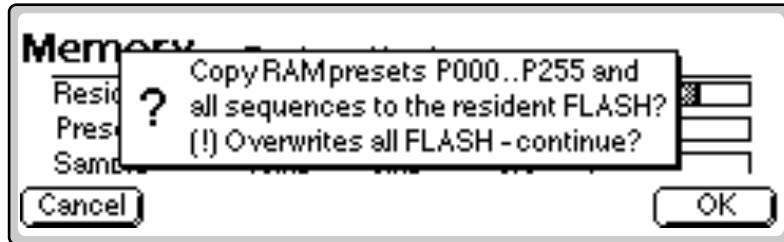

10. Press **OK** (F6) to confirm your choice or **Cancel** (F1) to cancel the operation.

Saving presets to floppy disk is just as easy. Copy the presets into RAM, then save to floppy.

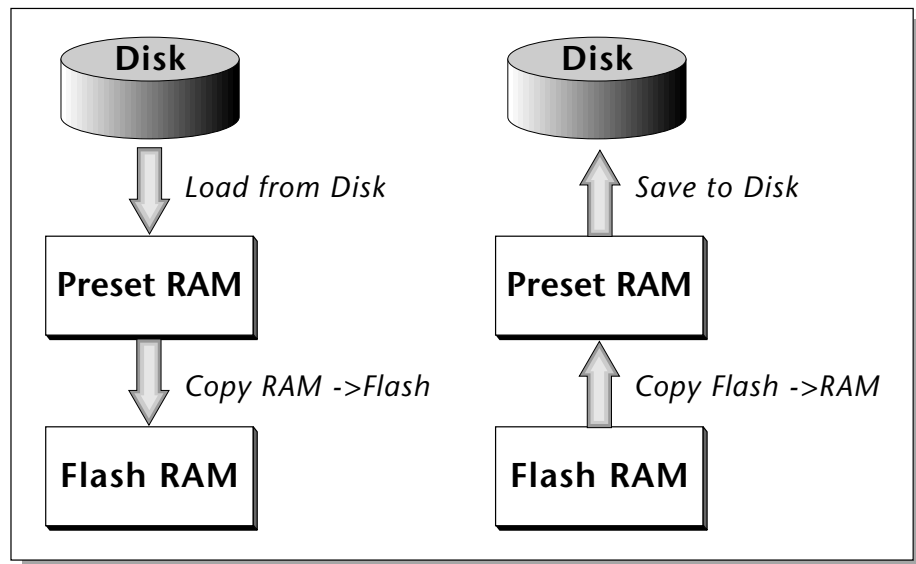

The Bank is used as an intermediary storage space when copying between the disk and Flash Memory. Data is copied into RAM first, then to disk or Flash.

Using Sound Flash Memory

Sound Flash Memory is similar to a hard disk containing one bank. A bank is assembled in Sample RAM, then Saved to Flash Memory. Individual presets cannot be saved to Flash Memory. The process of saving a bank to Flash is outlined below. Follow these instructions carefully.

☞ To Save a Bank to Flash Memory:

Erase the Bank

1. Press **Master**.
2. Press **Bank** (F2).
3. Press **Erase** (F1).

Load the Bank you Wish to Save to Flash

4. From the main screen, press the **Arrow** key, then **Load**.
5. Select the **Drive**, **Folder** and **Bank** you wish to Save, then press **Load**. The bank will load into RAM.

Save the Sounds to Flash

6. Press the **Arrow** key, then **Save**.
7. Select **Flash Memory** as the drive you wish to Save to, then press **OK** (F6). The Samples will be stored in Flash Sound RAM.

Mount the Drive

8. Press **Disk**.
9. Press **Utils** (F1).
10. Press **Mount** (F1).

Erase the Bank...again

11. Press **Master**.
12. Press **Bank** (F2).
13. Press **Erase** (F1).

Erase Preset 000

This operation deletes the empty preset in the P000 location of the bank so it won't get merged into your Flash Bank. Unfortunately, you must have at least one preset in the bank, so before deleting P000 we'll create a new empty preset at location 999.

14. Press **Preset Manage**.
15. Press **New...**
16. Select destination preset **P999 Empty Preset**.

17. Press **OK**, twice.
18. Select **P000** Untitled Preset.
19. Press **Utils** (F1).
20. Press **Erase Preset** (F1). Press **OK** (F6).

Merge the Presets

This operation merges the presets into the bank so that they will point to the correct locations in the Flash Sound Memory bank. The Emulator sees that the samples are in Flash Sound Memory and changes the sample numbers so they point to Flash.

21. From the main screen, press the **Arrow** key, then **Load**.
22. Select the **Drive**, **Folder** and **Bank** you wish to Save to Flash, then press **Merge**.

Save the Presets

Now that the sample numbers point to the samples in Flash Sound Memory, the presets can be written into CPU Flash memory using the Flash utilities.

23. Press **Master**.
24. Press **Bank** (F2).
25. Press **Flash** (F6).
26. Press **RAM ->F** (F3). A warning screen appears.
27. Press **OK** (F6). The presets will be written into CPU Flash memory.

To Copy Flash RAM Presets to Disk:

Power up the machine and wait for it to finish booting.

1. Press **Master**.
2. Press **Bank** (F2).
3. Press **Flash** (F6).
4. Press **F->RAM** (F4). A warning screen appears advising you that you are about to overwrite RAM.
5. Press **OK** (F6) to write to RAM.
6. Press **Master** to return to the main screen
7. Insert the **floppy disk** into the drive if you wish to copy to floppy disk.
8. Press **Save** (F5). The popup Save window appears.
9. Select the **destination Drive**, **Folder** and **Bank** for the flash presets.
10. When the parameters are properly set, press **OK** (F6). A warning screen appears warning you that you are about to overwrite a bank.
11. Press **OK** (F6) to save the bank to Disk or **Cancel** (F1) to cancel the operation.



☞ **To Copy Flash Sounds to Disk:**

It might be a good idea to back-up the factory samples before you overwrite the Flash Bank with your own sounds.

1. **Power up** the machine and wait for it to finish booting.
2. From the main screen, press the **Arrow** key, then **Load**.
3. Wait for the bank to finish loading, then press the **Arrow** key, then **Save**.
4. Select the **destination Drive, Folder** and **Bank** for the flash presets.
5. When the parameters are properly set, press **OK (F6)**.

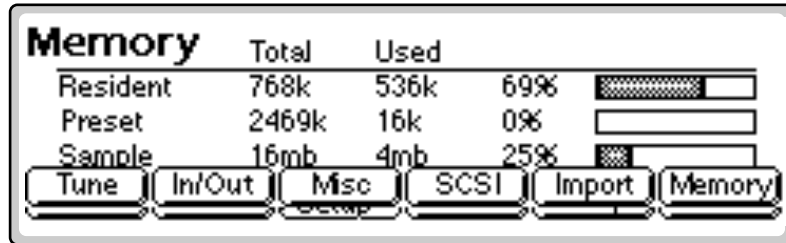
Setup

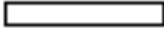

Memory	Total	Used	
Resident	768k	536k	69% 
Preset	2469k	16k	0% 
Sample	16mb	4mb	25% 

Tune In/Out Misc SCSI Import Memory

The Setup menu contains six additional submenus.

Tune. Contains three functions: tuning offset, transposition and audition key.

Input/Output. Contains several functions related to the audio and S/PDIF output levels.

Miscellaneous. Contains several miscellaneous functions.

SCSI/Disk. Contains several options relating to SCSI and SMDI. Also contains an option for routing the disk button.

Import Options. Contains preferences and controls for importing samples and presets from Akai™ or Roland™ samplers.

Memory Configuration. Allows you to control the amount of RAM allocated between the sequencer and presets.

Tune

This submenu contains three functions related to master tuning: Tuning Offset, Transposition, and Audition Key.

Tuning Offset

Tuning Offset adjusts the overall tuning so that you can tune to other instruments. The range of tuning offset is ± 100 cents or 1 semitone in approximately 1.5 cent increments.

To Change the Tuning Offset:

1. Press the **Master** button. The LED illuminates and the Memory Statistics screen appears.
2. Press the **Setup** function key (F3). A second row of function keys appears.
3. Press the **Tune** function key (F1). The following screen appears.

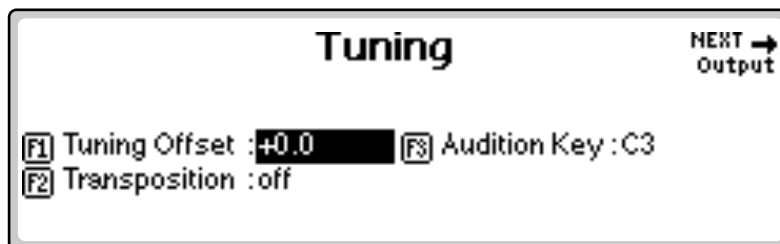

4. **Adjust the tuning offset.** If it is not already there, move the cursor to the tuning offset field using the cursor buttons or by pressing the F1 function key. Adjust the offset value using the Data Entry Control, or INC/DEC buttons.
5. Press the **Exit** button twice to return to the Memory Statistics screen.

Transpose

Transpose allows you to play in a different key without changing your fingering. This feature transposes the Emulator in half-step intervals and the transposition range is ± 1 octave. Transpose also lets you play beyond the range of the physical keyboard.

To Change the Transposition:

1. Press the **Master** button. The LED illuminates and the Memory Statistics screen appears.
2. Press the **Setup** function key (F3). A second row of function keys appears.
3. Press the **Tune** function key (F1). The Tuning screen appears.
4. **Adjust the transposition.** Move the cursor to the transposition amount using the cursor buttons or by pressing the F2 function key. Adjust the transposition value using the Data Entry Control, or INC/DEC buttons.
5. Press the **Exit** button twice to return to the Memory Statistics screen.



Turn off transposition before selecting or modifying any presets to avoid confusion. Transpose transposes the key number rather than the sample assignment. Selecting the zone and any other use of the keyboard will show the transposed key number.



The raw sample (at the original pitch) will be played if you audition from any sample-related screen (Sample Manage, Sample Edit, Disk Sample Browser).

Audition Key

This parameter lets you set the key that will be played when the front panel Audition Key is pressed, or the ASCII keyboard controlled audition command (Control, A) is applied.

To Change the Audition Key:

1. Press the **Master** button. The LED illuminates and the Memory Statistics screen appears.
2. Press the **Setup** function key (F3). A second row of function keys appears.
3. Press the **Tune** function key (F1). The Tuning screen appears.
4. Move the cursor to the **Audition Key field** using the cursor buttons or by pressing the F3 button.
5. Select the **Audition Key** using the Data Entry Control, INC/DEC buttons or the keyboard.
6. Press the **Exit** button twice to return to the Memory Statistics screen.

Input/Output

The Input/Output submenu contains functions dealing with the audio and digital outputs.

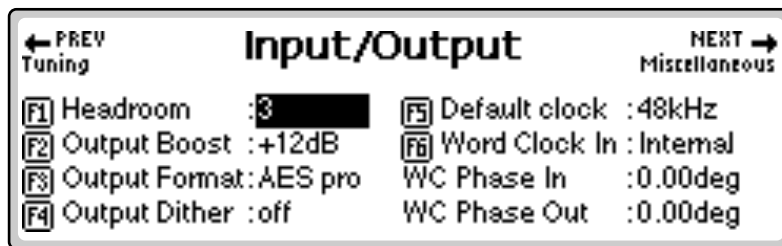

Suggested Settings

Polyphonic Music

Boost = 0

Headroom = 3

Single Sample Digital Transfer

Boost = +12

Headroom = 6 to 8

Headroom

Headroom is the amount of dynamic range remaining before clipping occurs. Think of a tall person (the signal) in a small room. Raising the ceiling increases the headroom or the amount of space between the top of the person's head and the ceiling.

The headroom adjustment, the master volume control, AES Boost and the zone level all control the output level of the digital audio output. These controls can be adjusted when transferring digital audio to optimize the signal level.

A sampling musical instrument, unlike a CD player, must play multiple channels at once and each additional channel increases the headroom requirement by 3 dB.

The amount of headroom is adjustable from 0 dB to 15 dB in 1 dB increments (with the front panel volume control set to maximum). A headroom setting of 0 dB for example, provides the hottest output level, (and the highest signal to noise ratio) but may produce “clipping” if too many notes are played at once. The default headroom setting is +3 dB, which maintains an excellent signal to noise ratio while keeping a reasonable amount of headroom in reserve. If you hear the signal clipping or breaking up, increase the amount of headroom. The headroom adjustment also controls the level of the S/PDIF digital output. Press **Exit** after setting the headroom to store the setting in FLASH RAM.

 *The headroom adjustment also controls the level of the digital audio output.*

 **To Change the Headroom:**

1. Press the **Master** button. The LED illuminates and the Memory Statistics screen appears.
2. Press the **Setup** function key (F3). A second row of function keys appears.
3. Press the **Output** function key (F2). The Output menu appears.
4. Advance the cursor to the **Headroom** field. Adjust the amount of remaining headroom using the Data Entry Control, or INC/DEC buttons.
5. Press the **Exit** button to return to the Setup screen. Press the **Exit** button again to return to the Memory Statistics screen.

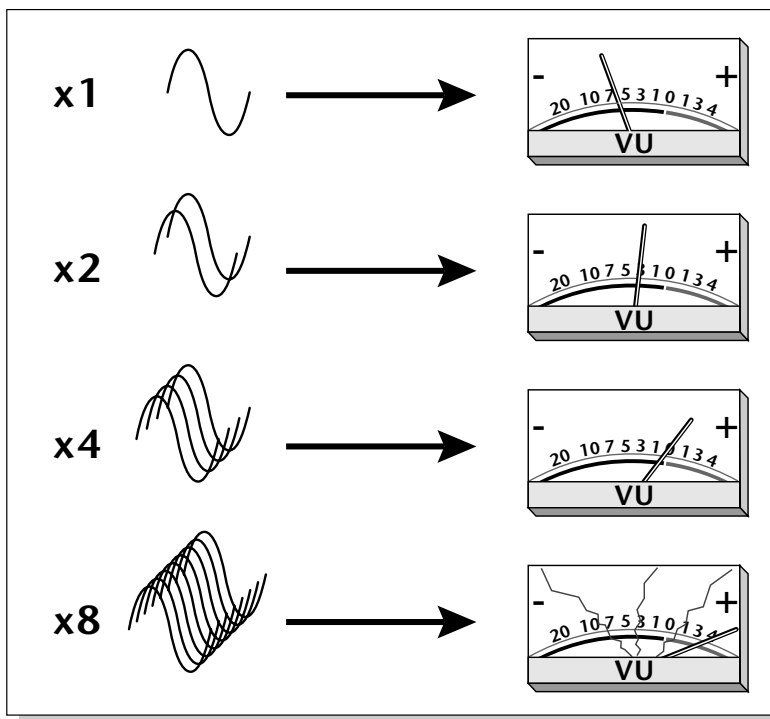

The more channels are played, the more headroom is required. Increasing the headroom lets you play more channels without clipping.

Output Boost

Output Boost is similar to the headroom control and digitally raises the output level by up to +12 dB. This option provides the best signal-to-noise ratio when only one or two channels are being played at a time. However, playing back too many channels with Output Boost turned on may cause the output signal to clip. This control affects both the analog and digital outputs.

To Change the Output Boost:

1. Press the **Master** button. The LED illuminates and the Memory Statistics screen appears.
2. Press the **Setup** function key (F3). A second row of function keys appears.
3. Press the **Output** function key (F2). The output menu appears.

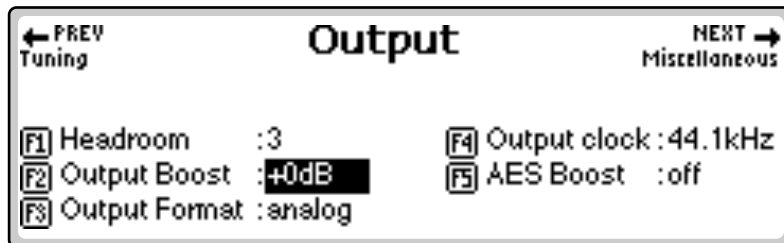

4. Set the output boost to +0 dB or +12 dB using the Data Entry Control, or INC/DEC buttons.
5. Press the **Exit** button twice to return to the Memory Statistics screen.

Output Format

The digital audio output (optional on the e-6400) is used for interfacing with other digital or analog audio equipment using either the AES/EBU (professional) or S/PDIF (consumer) formats. The digital audio interface carries two channels of audio information which mirror the audio at the main outputs. The analog and digital outputs are always active. This function optimizes the output for whatever format is being used. Set the Output Format to the digital format you are currently using: S/PDIF or AES pro.

To Change the Output Format:

1. Press the **Master** button. The LED illuminates and the Memory Statistics screen appears.
2. Press the **Setup** function key (F3). A second row of function keys appears.

 Always use high-quality, low-capacitance cable for the AES/EBU interface to insure data integrity.

3. Press the **In/Out** function key (F2). The output menu appears.
4. **Set the output format** to S/PDIF, AES pro or Analog using the Data Entry Control, or INC/DEC buttons.
5. Press the **Exit** button twice to return to the Memory Statistics screen.

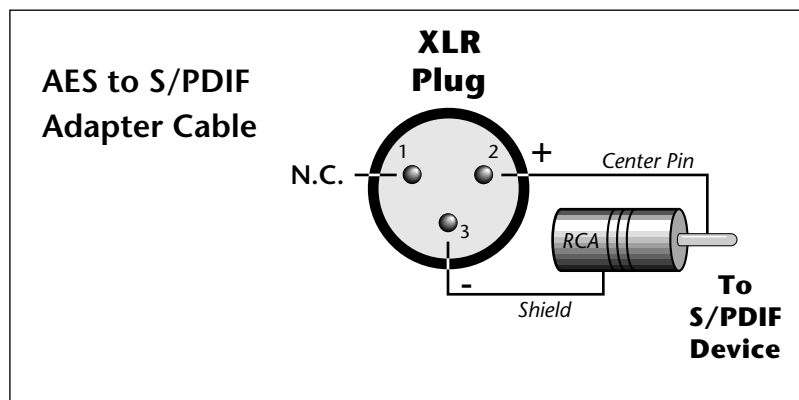

ADAT Output Dither

Dither is a technique used in digital systems to improve audio performance by adding noise to the least significant data bits. In general, dither is used whenever a digital number is converted to a smaller number (for instance when converting 20 bits to 16 bits).

As an example, suppose you were transferring ADAT optical data from the Ultra to an older ADAT recorder. The ADAT output is 20 bits wide while the older ADAT only receives data 16 bits wide. In this case you would turn **Dither On** because the receiving device has fewer bits. If you were sending data to a new ADAT which receives 20 bit data, you would turn **Dither Off**.

 **When to Dither?**

Add Dither - When sending ADAT data to a 16 bit device which doesn't dither at the input.

Don't Add Dither - When sending ADAT data to a 20-24 bit device.

To Turn ADAT Output Dither On or Off:

1. Press the **Master** button. The LED illuminates and the Memory Statistics screen appears.
2. Press the **Setup** function key (F3). Another row of function keys appears.
3. Press the **In/Out** function key (F2). The Input/Output screen appears.
4. Move the cursor to the **ADAT Output Dither** field using the cursor buttons or by pressing the F4 key.
5. **Turn Dither on or Off** using the Data Entry Control, or INC/DEC buttons.
6. Press the **Exit** button twice to return to the Memory Statistics screen.

Default Clock

Use the Default Clock to change the Emulator's output sample rate (clock rate) to either 44.1 kHz or 48 kHz. This function sets the output rate of the entire machine (analog as well as digital outputs). Digital audio recorders automatically record at the clock rate of the source, so set this control at 48 kHz to record into a DAT recorder.

Ultra Series. This function is tied to analog sampling on the Ultra series Emulators. There are four analog sample rates (22.05 kHz, 24 kHz, 44.1 kHz, 48 kHz), but depending on this setting only two are selectable at a time.

Default clock = 44.1 kHz (22.05 kHz & 44.1 kHz)

Default clock = 48 kHz (24 kHz & 48 kHz)

Change the default clock rate if the analog sample rate you want is not available in the Sample Manage module

☞ To Change the Default Clock Rate:

1. Press the **Master** button. The LED illuminates and the Memory Statistics screen appears.
2. Press the **Setup** function key (F3). Another row of function keys appears.
3. Press the **In/Out** function key (F2). The Input/Output screen appears.
4. Move the cursor to the **Default clock** field using the cursor buttons or by pressing the F4 key.
5. **Set the Default clock rate** using the Data Entry Control, or INC/DEC buttons.
6. Press the **Exit** button twice to return to the Memory Statistics screen.

 **Note:** If an external word clock is not physically connected, EOS defaults to its internal clock (even though the display is set to an external source).

Word Clock In

This Ultra function selects the Word Clock source. The Word Clock is the master time-base reference for the Emulator audio engine. Normally Word Clock In will be set to Internal to use the internal crystal-based reference. When transferring digital data, the different pieces of gear need to be synchronized to the same master clock. The BNC connector on the rear panel (*optional on some models*) allows the Emulator to synchronize with an external clock source (*a house sync generator or word clock out from another piece of digital gear*).

- **Internal** . Uses the Emulator's ultra-stable crystal reference oscillator.
- **BNC**..... Uses the word clock received at the rear panel BNC Word Clock In connector.
- **AES** Uses the word clock provided by the rear panel AES digital input connector.
- **ADAT** Uses the Word Clock embedded in the ADAT optical data.

To Set the Word Clock Source:

1. Press the **Master** button. The LED illuminates and the Memory Statistics screen appears.
2. Press the **Setup** function key (F3). Another row of function keys appears.
3. Press the **In/Out** function key (F2). The Input/Output screen appears.
4. Change the **Word Clock In** status. Move the cursor to Word Clock In using the cursor buttons or by pressing the **F6** function key. Choose the Word Clock source using the Data Entry Control, or INC/DEC buttons.
5. Press the **Exit** button to return to the Memory Statistics screen.

WC Phase In/Out

This Ultra function allows you to adjust the phase relationship between input and output sample clocking in order to compensate for clock phase delays in other equipment or when word clock is daisy-chained. On EOS machines, a setting of 0.00 degrees means that the word clock in phase is exactly equal to the word clock out. If you are having trouble synchronizing to other equipment, try adjusting the appropriate word clock phase control to remedy the problem.

WC Phase In. Adjusts the phase relationship between the input clock (BNC, AES, or ADAT) and the digital output embedded data clock.

WC Phase Out. Adjusts the phase relationship between the input clock (BNC, AES, or ADAT) and the Emulator Word Clock output.

Miscellaneous

The Misc submenu, as the name suggests, contains master miscellaneous functions such as setting the LCD contrast, screen saver, and global preferences.

Contrast

This function changes the contrast of the front panel LCD so that it may be read easily from different angles. The contrast is adjustable from +7 to -8. Adjust the contrast for the most comfortable viewing.

To Change the Contrast:

1. Press the **Master** button. The LED illuminates and the Memory Statistics screen appears.
2. Press the **Setup** function key (F3). A second row of function keys appears.
3. Press the **Misc** function key (F3). The Miscellaneous menu appears.

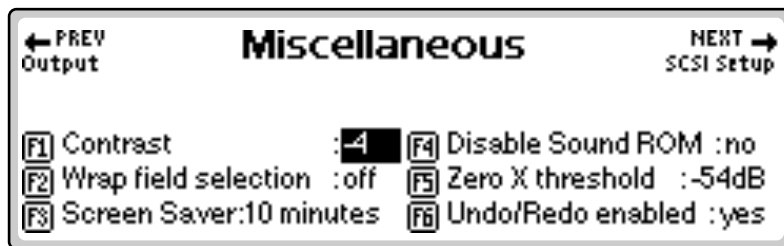

4. Move the cursor to the **Contrast** field using the cursor buttons or by pressing the F1 function key.
5. Adjust the **Contrast** using the Data Entry Control, or INC/DEC buttons.
6. Press the **Exit** button twice to return to the Memory Statistics screen.

Wrap Field Selection

When wrap field selection is enabled, moving the cursor past the last selection in a window makes it automatically jump back up to the first selection. With wrap field selection Off, the cursor will NOT move past the last selection in a window. You have to use the up or left cursor button to go back.

To Turn Wrap Field Selection On or Off:

1. Press the **Master** button. The LED illuminates and the Memory Statistics screen appears.
2. Press the **Setup** function key (F3). A second row of function keys appears.
3. Press the **Misc** function key (F3). The Miscellaneous menu appears.
4. Move the cursor to **Wrap Field Selection** using the cursor buttons or by pressing the F2 key.

5. Turn **Wrap Field Selection** On or Off using the Data Entry Control or INC/DEC buttons.
6. Press the **Exit** button twice to return to the Memory Statistics screen.

Screen Saver

After a period of inactivity, the LCD backlight dims in order to prolong the life of the LCD. This parameter sets the period of time from 10 to 60 minutes (in increments of 10 minutes) before the screen dims, or “Never” so that the backlight always stays on. This option is not available on e64 or EIV units.

To Turn the Screen Saver On or Off:

1. Press the **Master** button. The LED illuminates and the Memory Statistics screen appears.
2. Press the **Setup** function key (F3). A second row of function keys appears.
3. Press the **Misc** function key (F3). The miscellaneous menu appears.
4. Move the cursor to **Screen Saver** using the cursor buttons.
5. **Set the screen saver time** using the Data Entry Control, or INC/DEC buttons.
6. Press the **Exit** button to return to Memory Statistics.

Disable Sound ROM

Sample memory is user-expandable up to 64 megabytes with standard SIMM modules (up to 128 MB if ROM access is disabled). To use more than 64 MB of Sample Memory with the Sound ROM upgrade installed, you must turn off the Sound ROM. *This screen is only accessible if you have Sound ROM SIMMs installed.*

To Disable the Sound ROM:

1. Press the **Master** button. The LED illuminates and the Memory Statistics screen appears.
2. Press the **Setup** function key (F3). A second row of function keys appears.
3. Press the **Misc** function key (F3). The Miscellaneous menu appears.
4. Move the cursor to **Disable Sound ROM** using the cursor buttons or by pressing the F4 function key.
5. **Select Yes** to disable the Sound ROM using the Data Entry Control, or INC/DEC buttons.
6. Press the **Exit** button twice to return to the Memory Statistics screen.
7. **Reboot** the system.

 *You only need to disable the Sound ROM access if you have Sound ROM and want to use more than 64 MB of Sample memory.*

Zero Crossing Threshold

Background

The term “zero crossing” refers to the point at which the positive slope of a waveform passes through zero. In many sample editing applications, such as splicing and looping, it is useful to locate zero crossings in order to make glitch-free joins and loops. On some signals, however, a simple zero crossing may not be effective because the signal contains excessive noise or low-level, high-frequency harmonics. In these cases, every few samples may cross through zero. By setting a zero crossing threshold, we can ignore low-level zero crossings and wait for the signal to reach a certain level before choosing the next zero-crossing. Zero crossing threshold sets a level that a signal must exceed before the next zero crossing with a positive slope is selected. The defined zero crossing threshold is used in the Auto-Truncate function or whenever you manually select a zero crossing using the cursor buttons.

The following diagram illustrates zero crossing in action. The small x marks the initial position.

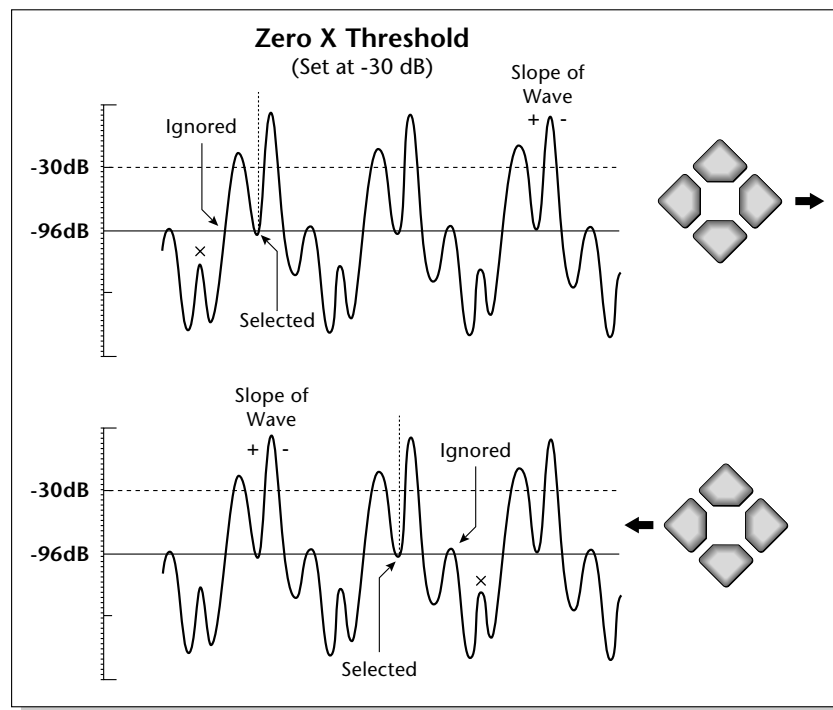

To move forward through the sound to the next zero crossing, press the right cursor button, as shown in the previous diagram. EOS finds the first zero crossing on the positive slope after the signal has crossed the threshold.

To move backward through the sound to the next zero crossing, press the left cursor button. EOS finds the first zero crossing on the positive slope after the signal has crossed the designated threshold.

Use the Data Entry Control or INC/DEC buttons to select the zero crossing threshold. A setting of -96 dB will be the most sensitive; a setting of -30 dB will be the least sensitive. The selected zero crossing threshold is used in the auto-truncate function or whenever you manually select a zero crossing using the left/right cursor buttons. If auto truncate does not seem to be working well, try adjusting the zero crossing threshold.

To Set the Zero-Crossing Threshold:

1. Press the **Master** button. The LED illuminates and the Memory Statistics screen appears.
2. Press the **Setup** function key (F3). A second row of function keys appears.
3. Press the **Misc** function key (F3). The Miscellaneous menu appears.
4. Move the cursor to **Zero-X Threshold** using the cursor buttons or by pressing the F5 function key.
5. Set the desired zero-crossing threshold using the Data Entry Control, or INC/DEC buttons.
6. Press the **Exit** button twice to return to the Memory Statistics screen.

Undo/Redo Enable

During many Sample Editing operations, the sample being processed is backed-up automatically and stored on the system drive. If you do not like the results of the processing, with Undo enabled you can call up the Undo function and restore the original sample from the system drive. (Ah, if only life itself were so simple.) Best of all, the processed sample is backed-up also. Therefore, if you decide you liked the processed version better after all, you can actually undo the Undo (Redo).

If you are running low on disk drive space, the display will inform you if there is not enough memory to back up a sample onto the system drive. You then have two choices: either free up some additional memory by erasing banks on the system drive, or disable the Undo/Redo using this function.

To Enable and Disable Undo/Redo:

1. Press the **Master** button. The LED illuminates and the Memory Statistics screen appears.
2. Press the **Setup** function key (F3). A second row of function keys appears.
3. Press the **Misc** function key (F3). The Miscellaneous menu appears.
4. Move the cursor to **Undo/Redo Enable** using the cursor buttons or the F6 function key.
5. Enable or disable **Undo/Redo** using the Data Entry Control, or INC/DEC buttons.
6. Press the **Exit** button twice to return to the Memory Statistics screen.

 Although the Undo/Redo feature lets you backtrack only one step, you can repeat the Undo and Redo commands an unlimited number of times.

 If you are using a removable media hard disk and do not have a fixed hard disk connected, it is recommended that you turn Undo/Redo OFF.

SCSI/Disk

Each Emulator has a SCSI device connector for attaching SCSI devices. You can have up to seven SCSI devices connected, or chained together. This chain is called a “bus.” Each device on the SCSI bus must have its own ID number. The SCSI/DISK submenu operations let you change the SCSI settings, including the SCSI ID of the Emulator, and program the function of the Disk button on the front panel of the unit.



SCSI ID

This utility allows you to change the SCSI ID number of the Emulator in the event that it conflicts with a device on the SCSI bus having the same ID number. For other units in the SCSI chain, refer to the manual that came with the hardware for instructions on how to change the SCSI ID.

 The SCSI ID of a device does not necessarily indicate the physical location of the device on the SCSI bus. For example, your Emulator can be the last item of three in the chain and have a SCSI ID of 2.

To Change the ID Number:

1. Press the **Master** button. The LED illuminates and the Memory Statistics screen appears.
2. Press the **Setup** function key (F3). A second row of function keys appears.
3. Press the **SCSI/Disk** function key (F4). The SCSI/Disk menu appears.
4. Move the cursor to the **SCSI ID number** using the cursor buttons or by pressing the F1 function key.
5. **Select the ID number** using the Data Entry Control, or INC/DEC buttons.
6. Press the **Exit** button twice to return to the Memory Statistics screen.

SCSI Termination On/Off

Both ends of a SCSI chain (meaning the first and last device on the bus) must be terminated for proper operation. If not properly terminated, the equipment can malfunction. Some equipment will not work at all if the chain is not properly terminated. Proper termination helps reduce line echoes or standing waves on the SCSI bus. This utility turns the SCSI termination on and off internal under software control. SCSI termination should usually be left on since the Emulator is normally connected at one end of the SCSI line.

To Turn SCSI Termination On or Off:

1. Press the **Master** button. The LED illuminates and the Memory Statistics screen appears.
2. Press the **Setup** function key (F3). A second row of function keys appears.
3. Press the **SCSI/Disk** function key (F4). The SCSI/Disk menu appears.
4. Move the cursor to the **SCSI Termination** field using the cursor buttons or by pressing the F2 function key.
5. Turn **SCSI Termination** On or Off using the Data Entry Control, or INC/DEC buttons.
6. Press the **Exit** button to return to the Memory Statistics screen.



This function tells EOS to avoid any host on the selected SCSI ID number. All Macs use ID 7. If you're a PC user, make sure this number matches your SCSI card.

Avoid Host on ID

SCSI was originally designed to have only one Master on the bus. EOS contains special software which lets multiple "Master" devices coexist peacefully on the SCSI bus. If you have a computer connected to the SCSI bus set this ID number so it matches your computer's SCSI card.

To Enable a Computer on the SCSI Bus:

1. Find out the **SCSI ID** of your computer's SCSI card. The Macintosh is set to ID #7. PCs use various SCSI ID numbers.
2. Press the **Master** button. The LED illuminates and the Memory Statistics screen appears.
3. Press the **Setup** function key (F3). A second row of function keys appears.
4. Press the **SCSI/Disk** function key (F4). The SCSI/Disk menu appears.
5. Move the cursor to "Avoid Host on ID" or press F4.
6. Set the **ID number** to avoid using the Data Entry Control, or INC/DEC buttons.
7. Press the **Exit** button to return to the Memory Statistics screen.

Disk Button Goes To:

This parameter lets you to set the function of the front panel disk button. The disk button can be set to jump directly into SoundSprint mode or it can call up the last Disk Browser screen you accessed.

☞ To Assign the Disk Button:

1. Press the **Master** button. The LED illuminates and the Memory Statistics screen appears.
2. Press the **Setup** function key (F3). A second row of function keys appears.
3. Press the **SCSI/Disk** function key (F4). The SCSI/Disk menu appears.
4. Move the cursor to the "**Disk Button goes to**" field using the cursor buttons or by pressing the F5 function key.
5. Select **Sprint** or **Last** using the Data Entry Control, or INC/DEC buttons.
6. Press the **Exit** button to return to the Memory Statistics screen.

 When browsing Roland disks, only Samples referenced by the selected Preset are displayed, unlike the Emulator where all Samples contained in the Bank are displayed.

 Complete Roland Volumes cannot be loaded because they may contain multiple MIDIMaps. Load "All Patches" instead.

Import Options

EOS can read Akai™ S1000, S1100, S3000 and Roland™ S-700 series disks. Samples, partials, patches, performances and volumes are automatically mapped into the appropriate Emulator parameters.

There are a few differences between these samplers and the Emulator. For this reason, some program parameters may be ignored during the conversion process. In most cases however, the converted programs and samples should sound and behave very much like the originals.



In the Roland disk structure, objects are allowed to exist outside of a containing parent object. For example in EOS, Samples are contained by Presets, which are contained by Banks and so on. In the Roland, samples can be saved by themselves outside a bank. To deal with this difference, a special browser item is added at the end of the Folder, Bank, Preset and Sample lists. These special objects are labeled "All" (as in All Patches) and contain all items of a particular type on the disk. This allows all objects on the disk to be browsed, including stray samples, presets or banks.

The following are descriptions of the EOS import options.

Combine L/R into Stereo: When this option is enabled, the Akai or Roland key groups are scanned for left/right samples that can be combined into a single stereo sample. If the first ten characters of the 12 character sample name match, and the last two characters are "-L" and "-R", as in Akai stereo samples, they will be combined into a single stereo sample (if the loop lengths match, otherwise the samples will be kept separate, as they are in the Akai.)

Roland Stereo Conversion - Program parameters for the new stereo sample are taken from the left sample. The right side parameters are ignored. When this function is disabled, each sample is placed in a separate voice.

Akai Conversion: Allows you to select between a basic or full conversion.

- **Basic** - Converts samples and keymaps only. Use this option when you just want the samples converted and placed on the keyboard. (Without all the preset programming.)
- **Full** - Assembles complete presets, simulating the originals as closely as possible.



Limitations for Roland Imports

- Supports 512 byte/sector devices only.
- Translates tuning, keymap, velocity switching and positional crossfade only. No envelopes, modulation filter settings cords, etc.
- Imports only one forward loop.

Adjust Fractional Loops: The Akai S1000 implements sample looping differently than the Emulator. Because of this difference, some loops may “tick” slightly or appear out of tune after being transferred from the Akai. This function automatically repairs any incorrect sample loops after being transferred. Be advised that the transfer may take slightly longer (up to 15% more time) with Adjust Fractional Loops turned enabled.

Foreign Sampler SCSI ID: If you have a brand of sampler other than the Akai or Roland connected to the SCSI bus, EOS needs to know its SCSI ID in order to avoid SCSI conflicts. The Foreign SCSI ID should be entered before physically connecting the sampler onto the SCSI chain. You do NOT have to set this parameter for Akai or Roland formatted storage devices. EOS recognizes them automatically.

To Set the Import Options:

1. Press the **Master** button. The LED illuminates and the Memory Statistics screen appears.
2. Press the **Setup** function key (F3). A second row of function keys appears.
3. Press the **Import** function key (F4). The Import Options menu appears.
4. Move the **cursor** to the desired option using the cursor buttons and change the parameter using the Data Entry Control or the INC/DEC buttons.
5. Press the **Exit** button twice to return to the Memory Statistics screen.

Memory Configuration

Presets and Sequences are stored in CPU RAM. CPU RAM is totally unrelated to the amount of Sample RAM you have in your machine. The E-IV, E4K, e-64 and e-6400 come with 1 MB of CPU RAM. The E4X and E-Synth come with 4 MB of CPU RAM. The Ultra series contain 8 MB of CPU RAM. CPU RAM is used by sequences, presets and the system. The amount of usable RAM on a 1 MB machine is approximately half a megabyte. A unit containing 4 MB of CPU RAM has about 2.6 MB of usable CPU RAM. Ultras contain about 4 MB of usable CPU RAM.

The Memory Configuration control lets you adjust the balance of CPU RAM allocated between the sequencer and the presets. If you find that a sequence is too large to be loaded, you can increase sequence memory size. If you run out of preset space, simply increase the amount of RAM allocated to presets.

To Set the Memory Configuration:

1. Press the **Master** button. The LED illuminates and the Memory Statistics screen appears.
2. Press the **Setup** function key (F3). A second row of function keys appears.
3. Press the **Memory** function key (F6). The Memory Configuration screen appears.



4. Adjust the **Preset** and **Sequence Memory Size** using the Data Entry Control or the INC/DEC buttons.
5. Press the **Save** button to save the changes or **Cancel** to return to the Memory Statistics screen.

Master Effects

You can assign the digital effect processors at the Preset level or on a Master level (which affects all presets). Since there are only two effect processors, you cannot assign a different effect to each preset when in Multi mode.

The Master Effects settings let you assign the effect processors “globally” for all presets so you can use the onboard effects like an external effects device. You might want the effects to be programmed on a global basis in Omni and Poly modes. You could choose your favorite reverb, for example, and have it applied to each preset you select. **Most importantly, the Master Effects settings provide a way to use the effects in Multi mode.**

To Program the Effects Globally for all Presets:

1. Press the **Preset Edit** button. The LED illuminates and the Preset Edit screen appears.

 Press the Controls key on the E4K or E-Synth Keyboard or press Assignable Key 2 while holding the Decimal Point on the other Emulator models, to access the FX menus that are currently in use.

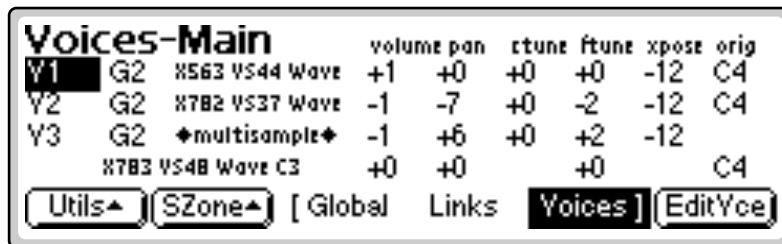

- If you are in a screen where the “Global, Links, Voices” function keys are not visible, press the Exit button once.
2. Press the **Global** function key (F3). The Global menu appears.
 3. Press the **Next** button. The Preset Effect A menu appears.
 4. Set the Effect field to **Master Effect**, which causes the Master effect settings to be used.
 5. Press the **Next** button again to go to the Preset Effect B menu. Set the Effect to the Master Effect setting if you want to use the Master settings.
 6. **Change each preset** in the bank to the Master Effect setting if you want the Master Effect setting used on all presets.
 7. Save the **bank**.

 For more detailed information about Effects see Chapter 3, Effects.

Use Master Effects Settings in MultiMode

In Multi Mode the two effects processors can be either controlled from the Master Effects settings or they can follow the effects settings of the preset on a special MIDI channel. Because up to 16 presets can play at once in multi mode, the effects cannot be programmed at the preset level. There are only two effects processors!

To Program the Effects Globally for all Presets:

1. Press the **Master** button. The LED illuminates and the Memory Statistics screen appears.
2. Press the **FX** function key (F4). A second row of options appears.
3. Press the **Setup** function key (F3). The Effects Setup menu appears.
4. Move the cursor to the **Effects Control** field using the cursor buttons.
5. Set the **Multi mode Effect Control Channel** to master settings using the Data Entry Control or INC/DEC buttons.
6. Press the **Exit** button three times to save the settings and return to the main screen.

Master Effects A

This function selects the type of effect used. The following effects are currently available:

A EFFECT TYPES

Room 1-3	Hall 1 & 2	Plate
Delay	Panning Delay	Multitap 1
Multitap Pan	3 Tap	3 Tap Pan
Soft Room	Warm Room	Perfect Room
Tiled Room	Hard Plate	Warm Hall
Spacious Hall	Bright Hall	Bright Hall Pan
Bright Plate	BBall Court	Gymnasium
Cavern	Concert 9	Concert 10 Pan
Reverse Gate	Gate 2	Gate Pan
Concert 11	Medium Concert	Large Concert
Large Concert Pan	Canyon	DelayVerb 1-3
DelayVerb 4-5 Pan	DelayVerb 6-9	

2 - Master Menu Effects Setup



A warning message appears if an effect routing other than "Master" is currently selected.

Master Effects B

This function selects the type of effect used. The following effects are currently available:

B EFFECT TYPES

Chorus 1-5	Doubling	Slapback
Flange 1-7	Big Chorus	Symphonic
Ensemble	Delay	Delay Stereo 1 & 2
Panning Delay	Delay Chorus	Pan Delay Chorus 1 & 2
Dual Tap 1/3	Dual Tap 1/4	Vibrato
Distortion 1 & 2	Distortion Flange	Distorted Chorus
Distorted Double		



Please refer to Chapter 3, Effects for detailed information concerning the Effects.

Effects Setup

The Effects Setup page contains two effects control functions. The first allows the entire effects subsystem to be bypassed if you don't want internal effects.

The Multimode Effects Control lets the effects be controlled by the Master module settings or by a specific preset when in Multimode.

To Enable or Disable the Effects:

1. Press the **Master** button. The LED illuminates and the Memory Statistics screen appears.
2. Press the **FX** function key (F4). A second row of function keys appears.
3. Press the **Setup** function key (F3). The Effects Setup menu appears.
4. **Enable or Bypass the internal effects** using the INC/DEC buttons or Data Entry Control.
5. Press the **Exit** button twice to return to the Memory Statistics screen.

Effects Control

The effects processor controls are very flexible. They can be controlled in three different ways to suit your personal preference and to adapt to different situations.

1. Programmed as part of the preset when playing single presets (Omni or Poly Modes).
2. Programmed from the Master Effects Section when playing either single presets (preset Effect Type set to "Master") or when in Multi mode.
3. Programmed from the designated control preset when in Multimode. The Effects Control parameter sets the MIDI channel whose preset will control the effects processors.

 You can create special presets without samples to be used as "Effects Presets." By assigning these effects presets to the Multi mode Effects Control Channel, you can use Program Change commands to switch between effects during a sequence.

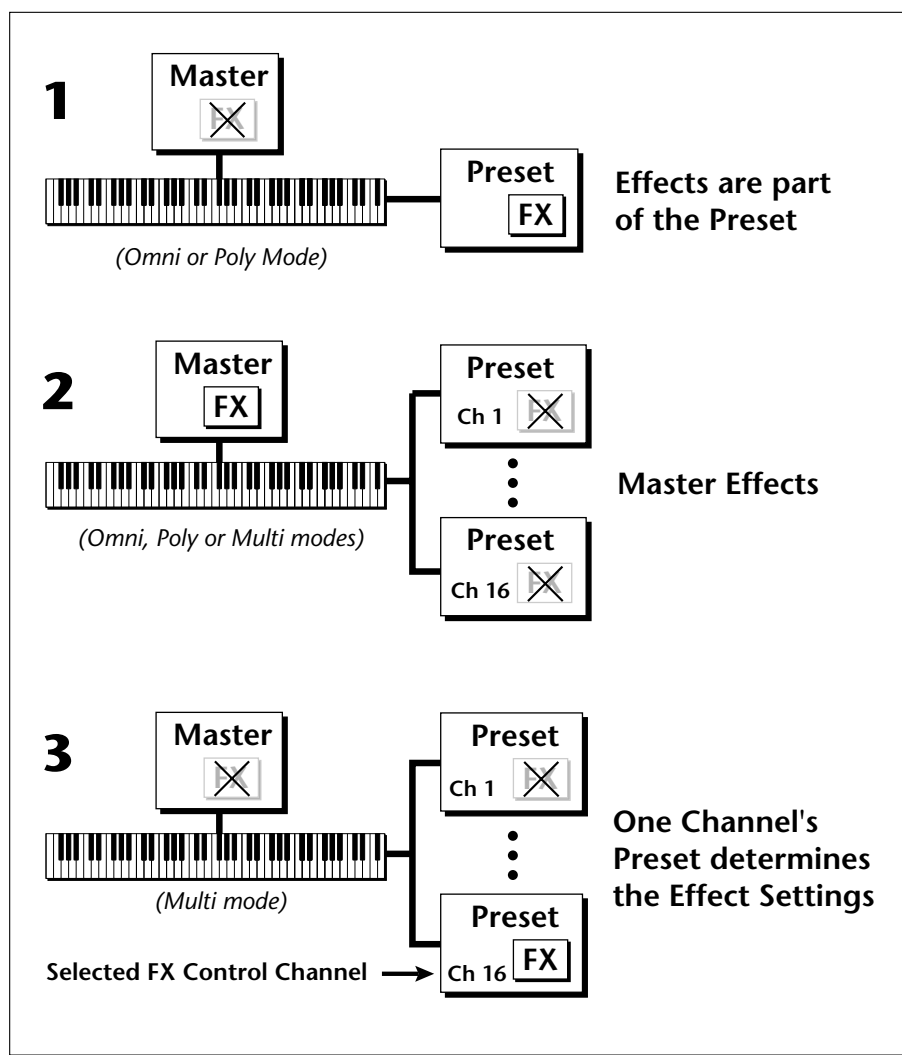

Effects selection can be made in three different ways.

2 - Master Menu Effects Setup

In Multimode the two effects processors can be either controlled from the Master Effects settings or they can follow the effects settings of the preset on a specific MIDI channel. This feature allows you to change effects during a sequence.

To Set the Multimode Effects Control Channel:

1. Press the **Master** button. The LED illuminates and the Memory Statistics screen appears.
2. Press the **FX** function key (F4). A second row of function keys appears.
3. Press the **Setup** function key (F3). The Effects Setup menu appears.
4. Move the cursor to the **Multimode Effects Control** field using the down cursor button.
5. Select the desired **MIDI channel** or “**Master Settings**” using the Data Entry Control, or INC/DEC buttons.

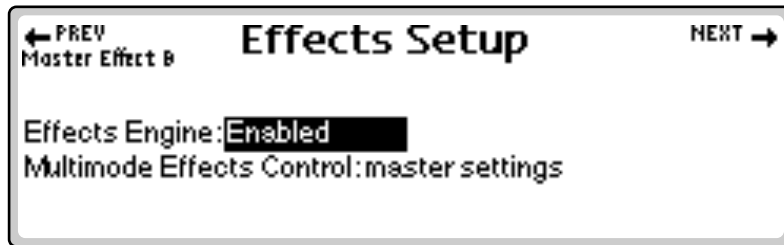

6. Press the **Exit** button twice to return to the Memory Statistics screen.

Sequence Manage

EOS version 4 contains a powerful 48-track onboard sequencer, always available to capture your musical ideas. The sequencer's easy to use interface lets you lay down tracks almost as fast as you can play them. **Please refer to Chapter 4, Sequencer for detailed information on the sequencer.**

The Sequence Manage menu displays the memory used and the number of tracks in the current sequence and contains the following functions:

Utilities. Contains Erase and Copy commands.

Name. Allows you to name your sequences.

Export. Exports the currently selected sequence as a Standard MIDI File.

Loop. Sets the sequence to play continuously or to stop playing once it reaches the end.

Edit. The Edit function key toggles between the main sequencer functions and the sequence editor functions.

Menu/Transport. Toggles between the Sequence Manager functions and the Transport Control keys.

MIDI

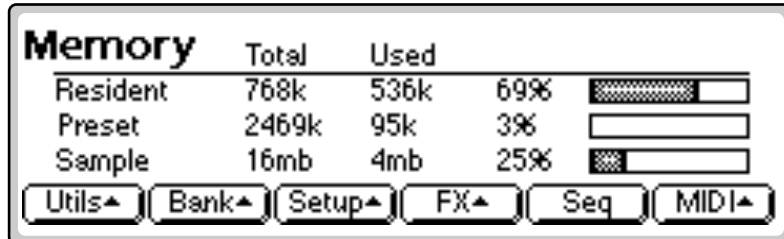

Memory	Total	Used	Percentage	Progress Bar
Resident	768k	536k	69%	
Preset	2469k	95k	3%	
Sample	16mb	4mb	25%	

Navigation buttons: Uutils▲, Bank▲, Setup▲, FX▲, Seq, MIDI▲

The MIDI menu changes the MIDI parameters which affect the overall MIDI operation. The MIDI menu is accessed by pressing the **MIDI** key from the Memory Statistics screen.

The MIDI menu contains three submenus:

Mode. Selects MIDI basic channel, mode, device ID and local control status.

Controls 1 & 2. Sets the controller and MIDI controllers received by the Emulator (and Sent on the E4K and E-Synth Keyboard).

Preferences 1 & 2. Miscellaneous MIDI preference functions such as velocity curve, controller sensitivities, etc., which are stored in Flash RAM.

MIDI Mode

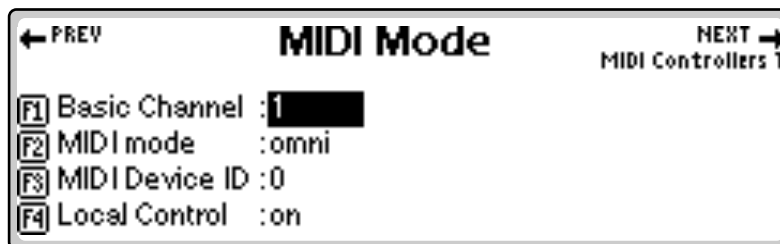

 The Basic Channel can also be set from the Multi mode screen on the E4K or E-Synth Keyboard. Simply select the desired channel and press the **SetBCh** function key (F2).

Basic Channel

The Basic MIDI Channel is the channel transmitted through the MIDI Out port (on the E4K and E-Synth Keyboard) and is the channel that will be recorded into the sequencer. It is also used in the special case of Poly mode. In Poly mode, MIDI data is only received on the selected basic channel and data on all other channels is ignored.

To Set the Basic MIDI Channel

1. Press the **Master** button. The LED illuminates and the Memory Statistics screen appears.
2. Press the **MIDI** function key (F6). The MIDI Globals sub menu appears.
3. Press the **Mode** function key (F1). The MIDI Mode menu appears.
4. Move the cursor to **Basic Channel** using the cursor buttons or the F1 key.
5. Set the **Basic MIDI channel** using the Data Entry Control, or INC/DEC buttons.
6. Press the **Exit** button twice to return to the Memory Statistics screen.

MIDI Mode

Any of three MIDI modes can be used:

Omni Mode. Receives MIDI data on any and all channels at once and plays the current preset.

Poly Mode. Receives MIDI data only on the basic channel and plays the current preset.

Multimode. Receives MIDI data on any and all channels at once and plays the preset assigned to each MIDI channel as assigned in the main Multi mode screen.

 **To Change the MIDI Mode:**

1. Press the **Master** button. The LED illuminates and the Memory Statistics screen appears.
2. Press the **MIDI** function key (F6). The MIDI Globals submenu appears.
3. Press the **Mode** function key (F1). The MIDI Mode menu appears.

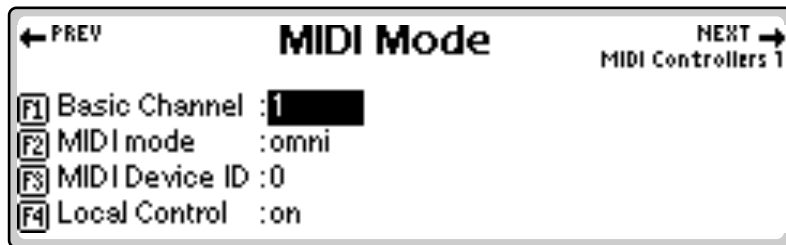

4. Move the cursor to **MIDI mode** using the cursor buttons or the F2 function key.
5. Change the **MIDI mode** using the Data Entry Control, or INC/DEC buttons.
6. Press the **Exit** button twice to return to the Memory Statistics screen.

MIDI Device ID

This function allows an external SysEx programming device to distinguish between multiple Emulator units. In this case, each Emulator should have a different ID number. When transferring SysEx data between two EOS units, the ID numbers must be the same. Got it?

 **To Change the MIDI Device ID:**

1. Press the **Master** button.
2. Press the **MIDI** function key (F6).
3. Press the **Mode** function key (F1).
4. Move the cursor to **MIDI Device ID** using the cursor buttons or the F3 function key.
5. Change the **Device ID** using the Data Entry Control, or INC/DEC buttons.
6. Press the **Exit** button twice to return to the Memory Statistics screen.

 Local Control is available only on E4K and E-Synth Keyboards.

Local Control

Local Control is used to disconnect the keyboard and controllers (wheels, sliders, pedals, etc.) from the sound generating section. The keyboard and controls are still transmitted over MIDI however. Local Control is normally turned Off when recording into a MIDI sequencer (set sequencer to Echo Thru).

To Turn Local Control On or Off:

1. Press the **Master** button. The LED illuminates and the Memory Statistics screen appears.
2. Press the **MIDI** function key (F6). The MIDI Globals sub menu appears.
3. Press the **Mode** function key (F1). The MIDI Mode menu appears.
4. Move the cursor to **Local Control** using the cursor buttons or the F4 key.
5. Turn **Local Control** On or Off using the Data Entry Control, or INC/DEC buttons.
6. Press the **Exit** button twice to return to the Memory Statistics screen.

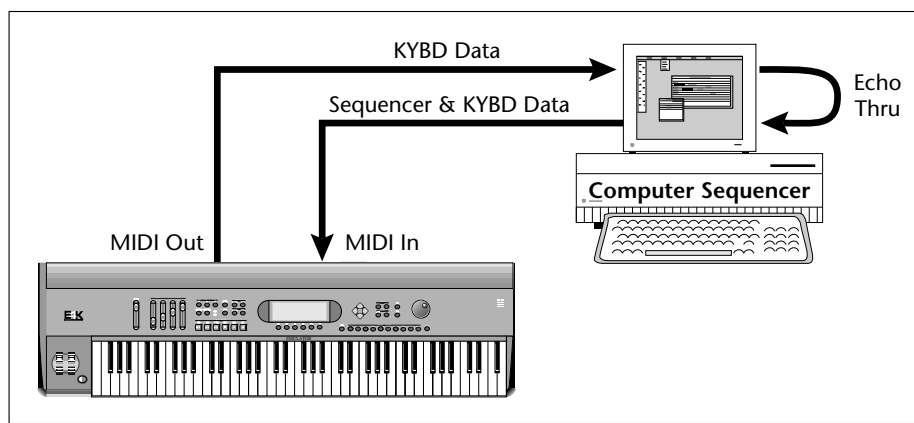

Turning Local Control Off allows you to use the Echo Thru feature on your sequencer while sequencing. If Local Control were turned on in the example above, notes played on the keyboard would be echoed back by the sequencer and sound twice.



Volume = MIDI

continuous controller chan. #7

Pan = MIDI continuous

controller chan. #10

Multimode - MIDI Mix

When Multimode is selected as the MIDI mode, the main display transforms from a single preset selection screen into a MIDI Mix screen. The MIDI Mix screen allows you to display and adjust the preset, volume, pan settings and output assignments for up to 32 MIDI channels. This is a useful feature to fine tune multi-timbral sequences. This screen also allows you to override the output channel programmed in the voice. Any volume, pan and preset changes made over MIDI will be reflected in this display.

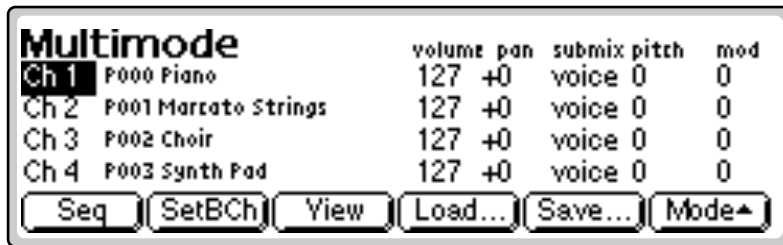

🔧 To Change the MIDI Mix

1. Set the **MIDI** mode to Multi as described on the previous page or simply select **Multi** after pressing the **Mode** button on the main preset screen.
2. Use the up/down cursor to select the **MIDI channel**. The selected channel will be recorded on the first track.
 - Press the **Right Arrow** button to display (or change) the values of MIDI controllers A-H. These values can also be edited just as if you were moving the actual controller.

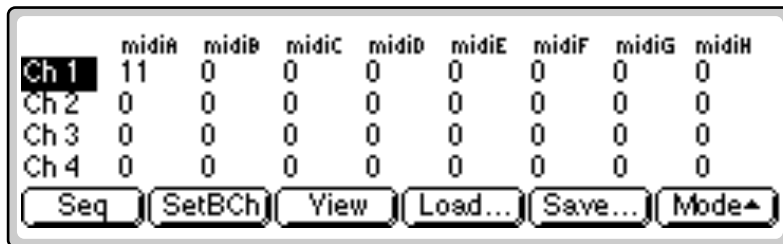

3. Press the **View** button to toggle the MIDI Mix back to graphic display mode.

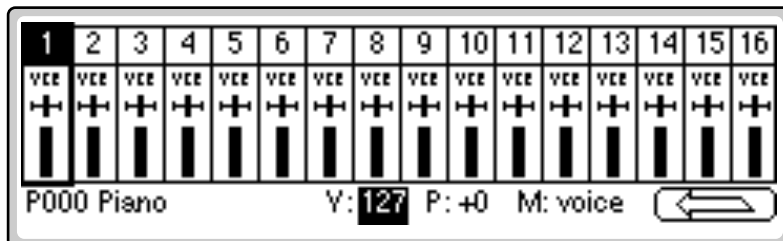

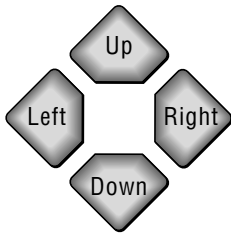

 Pan ADDS to the pan setting made in the voice and is not an absolute pan setting.

4. Select the desired MIDI channel using the up/down cursor buttons.

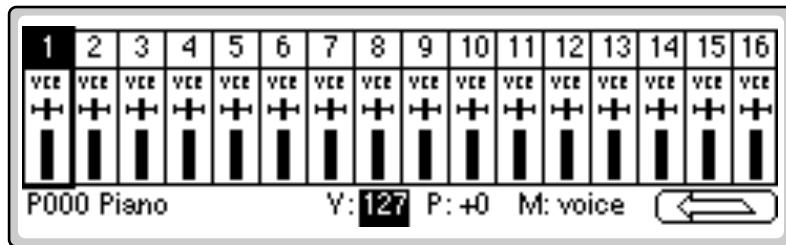

5. Select preset, volume, pan or the output channel using the left/right cursor buttons. Change the parameter values using the Data Entry Control, the INC/DEC buttons, or the numeric keypad.
6. Set the keyboard mode to "whole" to change the main screen back to a single preset display format.
7. Press the left arrow function key (F6) and then the View function key to change the display to list view mode.

The list view screen displays the values of the pitch and modulation wheels. The amounts of the wheels can also be adjusted, just as if you were moving the wheels to the left of the keyboard.

 **If you have an Ultra or a MIDI Channel Expander Card Installed:**

1. Press the Next key to view the additional MIDI channels. The diagram below shows how the MIDI channels on the expander port correspond to internal channels.

 To Change Program Banks via MIDI, send:
1) Continuous Controller 00 = 0
2) Cont. Controller 32 = Bank #
3) Program Change

This allows you to access presets higher than 128 via MIDI.

On your sequencer: Use Continuous Controller #32

Incoming	Internal
Chan 1	Chan 17
Chan 2	Chan 18
Chan 3	Chan 19
Chan 4	Chan 20
Chan 5	Chan 21
Chan 6	Chan 22
Chan 7	Chan 23
Chan 8	Chan 24

Incoming	Internal
Chan 9	Chan 25
Chan 10	Chan 26
Chan 11	Chan 27
Chan 12	Chan 28
Chan 13	Chan 29
Chan 14	Chan 30
Chan 15	Chan 31
Chan 16	Chan 32

MIDI Controllers

About MIDI Controllers

You probably already know that each MIDI cable can carry up to 16 MIDI channels. Each of the 16 MIDI channels uses basically 3 types of messages; note on/off, program changes, and continuous controller messages.

-  A few of the standardized MIDI Controller numbers are listed below.
- 0 - MIDI Bank Chng MSB
 - 1 - Modulation Wheel
 - 2 - Breath Controller
 - 3 - Old DX7 Aftertouch
 - 4 - Foot Pedal
 - 5 - Portamento Time
 - 6 - Data Entry
 - 7 - Volume
 - 8 - Balance
 - 9 - Undefined
 - 10 - Pan
 - 11 - Expression
 - 32 - MIDI Bank Chng LSB
 - 64 - Sustain (on/off)
 - 65 - Portamento (on/off)
 - 66 - Sostenuato (on/off)
 - 67 - Soft Pedal (on/off)
 - 69 - Hold Pedal (on/off)

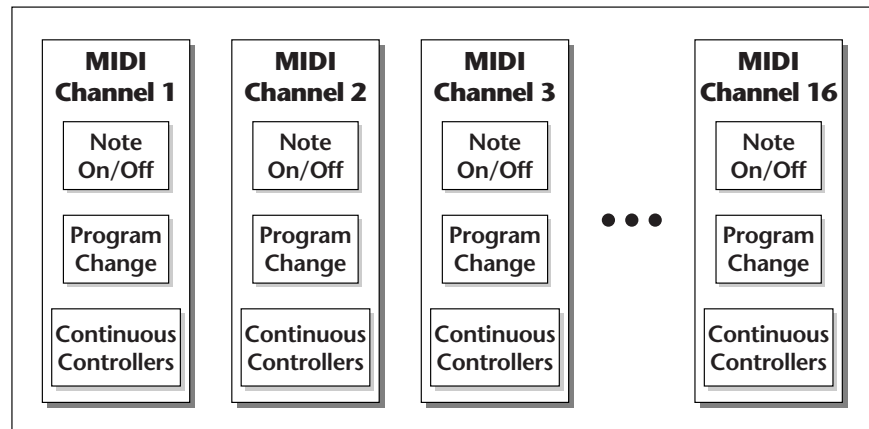

Most MIDI keyboards, in addition to describing which note was played, also send realtime control information. Realtime control sources on the E4K and E-Synth Keyboard include such things as the pitch wheel, modulation wheel, control pedal, aftertouch, the two footswitches and the four realtime control sliders. All these controls are designed to give you more expression in your music.

Realtime controller information is sent on separate channels called continuous controller channels. There is a set of 128 continuous controller channels for each of the 16 MIDI channels. Some of the controller channels, such as Mod Wheel, volume, and pan have been standardized. For example, volume is usually sent on continuous controller channel #7.

Any continuous controller can be internally routed to any realtime modulation destination. The internal connections for a particular preset are completed in the Preset Edit menu.

The realtime controllers of the E4K and E-Synth Keyboard are transmitted out the MIDI port on the controller number you specify. Simply set the controller number of the slider (A-D) so that it matches the number on the receiving device. (Make sure the MIDI channels are the same too.) That's it!

-  Only the E4K and E-Synth Keyboard have "Thumb Control." On other Emulator units, the option is called Switch 3 Control.

This menu allows you to assign up to 15 MIDI continuous controllers which will be received by EOS. The controllers on page one, as well as MIDI A-H on page two, are transmitted on the controller channel shown. These MIDI controller assignments set here are global and used by all presets. (Note: the names attached to the controllers such as “Pitch Control” and “Mod Control” are arbitrary. They can be assigned to any destination in the Preset Edit menu.)

 On the E4K and E-Synth Keyboard the four realtime controller sliders are permanently assigned to MIDI controllers A-D.

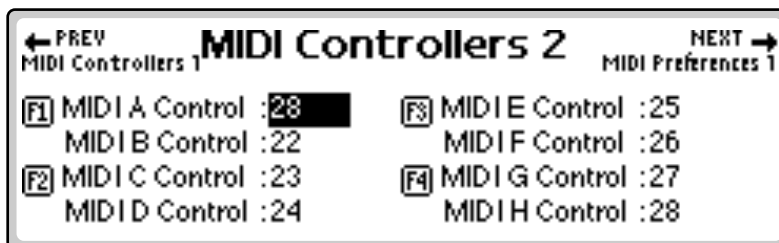
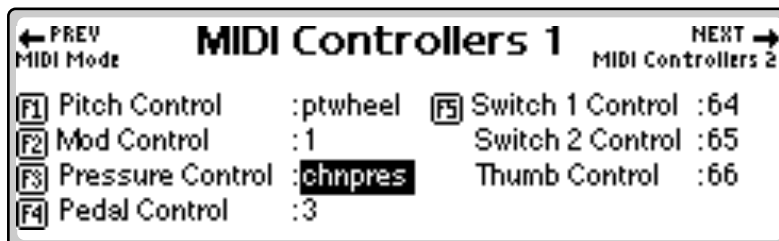

 MIDI continuous controller 7 is permanently assigned to volume and controller 10 is assigned to pan. Using these numbers for other functions could have unpredictable results.

 Assigning the MIDI Controller is only half of the connection. The controller's destination must be assigned in the Preset Edit, Cords submodule.

To Setup the MIDI Controllers

1. Press the **Master** button. The LED illuminates and the Memory Statistics screen appears.
2. Press the **MIDI** function key (F6). The MIDI Globals sub menu appears.
3. Press the **Controls 1 or 2** function key (F2 or F3). The MIDI Controllers menus shown above appears.
4. **Select the desired controller name** using the cursor buttons or the indicated function keys.
5. **Select the MIDI controller numbers** using the Data Entry Control, or INC/DEC buttons.
6. Press the **Exit** button twice to return to the Memory Statistics screen.

MIDI Preferences

This submenu contains several additional global MIDI functions.

Velocity Curve

Incoming velocity values can be scaled by one of fourteen curves to better adapt to your playing style or MIDI controller. Selecting “linear” leaves the velocity data unaltered. The shape of the selected curve is displayed in the window. Select the curve that works best for you.

To Set the Velocity Curve:

1. Press the **Master** button. The LED illuminates and the Memory Statistics screen appears.
2. Press the **MIDI** function key (F6). The MIDI Globals sub menu appears.
3. Press the **Prefs 1** function key (F4). The MIDI Preferences submenu appears.

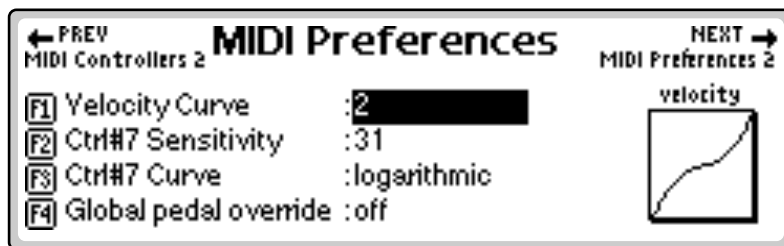

4. Move the cursor to **Velocity Curve** using the cursor buttons or the F1 key.
5. Set the **Velocity Curve** using the Data Entry Control, or INC/DEC buttons.
6. Press the **Exit** button twice to return to the Memory Statistics screen.

Controller #7 Sensitivity

This function allows you to modify the response curve for MIDI continuous controller #7 (Volume). This allows you to match the Emulator's response to other manufacturer's equipment. Low numbers compress the volume control range, raising the volume level at lower controller #7 values. The action of this control is displayed in the curve display on the right side of the screen.

To Adjust MIDI Controller #7 Sensitivity:

1. Press the **Master** button. The LED illuminates and the Memory Statistics screen appears.
2. Press the **MIDI** function key (F6). The MIDI Globals submenu appears.

3. Press the **Prefs 1** function key (F4). The MIDI Preferences 1 submenu appears.
4. Move the cursor to **Ctrl #7 Sensitivity** or use the F2 key.
5. While sending controller #7 messages **adjust the sensitivity** using the Data Entry Control, or INC/DEC buttons.
6. Press the **Exit** button twice to return to the Memory Statistics screen.

Controller #7 Curve

This is another adjustment to help match the Emulator to other manufacturer's equipment. Three curves are provided: Linear, Squared or Logarithmic. The action of this control is displayed in the curve display on the right side of the screen.

To Adjust MIDI Controller #7 Curve:

1. Press the **Master** button. The LED illuminates and the Memory Statistics screen appears.
2. Press the **MIDI** function key (F6). The MIDI Globals sub menu appears.
3. Press the **Prefs 1** function key (F4). The MIDI Preferences 1 submenu appears.
4. Move the cursor to **Ctrl #7 Curve** or use the F3 function key.
5. While sending controller #7 messages **adjust the curve** using the Data Entry Control, or INC/DEC buttons.
6. Press the **Exit** button twice to return to the Memory Statistics screen.

Global Pedal Override

This feature, when enabled, overrides any footpedal assignments made in the preset and forces the footpedal to become a master volume pedal which emulates the front panel volume control.

To Turn Global Pedal Override On/Off

1. Press the **Master** button. The LED illuminates and the Memory Statistics screen appears.
2. Press the **MIDI** function key (F6). The MIDI Globals sub menu appears.
3. Press the **Prefs 1** function key (F4). The MIDI Preferences 1 submenu appears.
4. Move the cursor to **Global Pedal Override** using the cursor buttons or the F4 function key.
5. Turn **Global Pedal Override On or Off** using the Data Entry Control, or INC/DEC buttons.
6. Press the **Exit** button twice to return to the Memory Statistics screen.



To Change Program

Banks via MIDI, send:

- 1) Continuous Controller 00 = 0
- 2) Cont. Controller 32 = Bank #
- 3) Program Change

This allows you to access presets higher than 128 via MIDI.

On your sequencer: Use Continuous Controller #32



Program Change

commands will not be transmitted while EOS is in Multi mode.

Receive Program Change On/Off

With Receive Program Change turned on, EOS applies any incoming MIDI program change commands. If disabled (turned off), MIDI program changes are ignored by the system.

To Turn Receive Program Change On/Off

1. Press the **Master** button. The LED illuminates and the Memory Statistics screen appears.
2. Press the **MIDI** function key (F6). The MIDI Globals sub menu appears.
3. Press the **Prefs 2** function key (F5). The MIDI Preferences 2 submenu appears.
4. Move the cursor to **Receive Program Change On/Off** using the Cursor buttons or the F1 key.
5. Turn **Receive Program Change On or Off** using the Data Entry Control, or INC/DEC buttons.
6. Press the **Exit** button twice to return to the Memory Statistics screen.

Send Program Change On/Off

With the Send Program Change enabled, MIDI program change commands are sent to the MIDI Out port. If disabled, preset change commands are not delivered to the MIDI out port. Enable this feature if you want to send MIDI Program Change commands to another instrument or unit through the MIDI out connection on the Emulator.

To Send Program Change:

1. Press the **Master** button. The LED illuminates and the Memory Statistics screen appears.
2. Press the **MIDI** function key (F6). The MIDI Globals submenu appears.
3. Press the **Prefs 2** function key (F5). The MIDI Preferences 2 submenu appears.
4. Move the cursor to **Send Program Change On/Off** using the cursor buttons or the F2 key.
5. Turn **Send Program Change On or Off** using the Data Entry Control, or INC/DEC buttons.
6. Press the **Exit** button twice to return to the Memory Statistics screen.

 Make sure to send the two program changes as separate events. Some sequencers send only one program change if the two are located on the same beat.

Magic Load Preset

This feature lets a MIDI command load banks from the hard disk. The “Magic Preset” is a preset number that causes the next preset change command to load that bank number from the hard disk. Therefore, to load a hard disk bank over MIDI, send two program change commands, the Magic Preset and the bank number. As an example, if the Magic Preset is set at “P85,” and the Emulator receives a preset change command of 85 followed by a preset change command of 11, the Emulator loads bank 11 from the current drive and folder on the current hard disk. The Magic Preset can be turned off or set to any preset number from 0 to 127.

To Set the Magic Preset

1. Press the **Master** button. The LED illuminates and the Memory Statistics screen appears.
2. Press the **MIDI** function key (F6). The MIDI Globals sub menu appears.
3. Press the **Prefs 2** function key (F5). The MIDI Preferences 2 submenu appears.

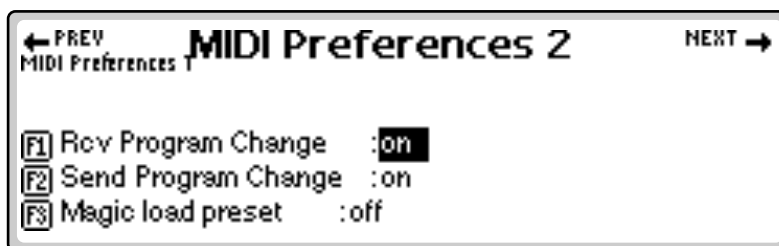

4. Move the cursor to **Magic Load Preset** using the cursor buttons or the F3 function key.
5. Set the **Magic Preset** using the Data Entry Control, or INC/DEC buttons.
6. Press the **Exit** button twice to return to the Memory Statistics screen.

2 - Master Menu

Effects

3

3 - Effects

Effects

 Effects come standard on E4X, E-Synth and all Ultra units. They are an option on the E-6400, E4K and EIV.

Dual Effects Processor

Emulators contain two stereo effects processors. When playing presets one at a time, the two processors can be programmed as part of the preset. When in Multimode, EOS uses a global effects assignment. The diagram below shows how the effects are integrated into the signal path using a parallel effects send/return model similar to a mixing console.

Effects processor “A” contains Reverb and Delay effects and Effects processor “B” contains Chorus, Flange and Distortion effects. There are 44 “A” effects and 32 “B” effects. In addition to the effect type, there are three user adjustable parameters for each effect. The “A” effects have user programmable Decay Time and High Frequency Damping. The “B” effects have user programmable Feedback, LFO Rate and Delay Time.

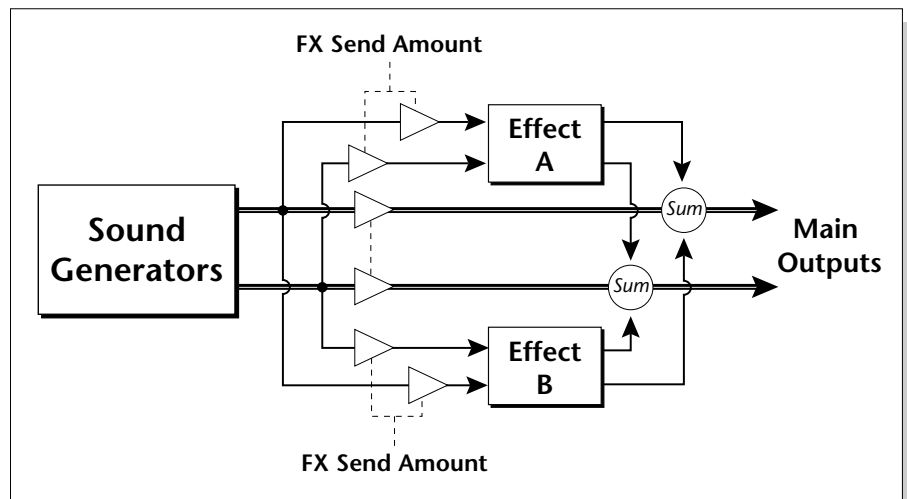

 Unlike a mixing console, the dry signal begins to be attenuated as the Send Amount is increased beyond 50%. This allows a mix of 100% effect.

The Effects Sends

On a mixing console you can control the amount of signal each channel sends to the effect bus. This lets each channel be placed in a slightly different “sonic space” creating an airy, open sound.

EOS uses this basic concept, but works in a slightly different manner. There are 4 effects busses: Main, Sub 1, Sub 2, and Sub 3. Each voice or each MIDI channel (you determine which), can be directed to one of the four busses. Each effects processor contains four Send Amounts sets the wet/dry mix on each of the four busses going into the effect. A setting of 0% is completely dry (no effect). A setting of 50% contains an equal mix of affected and normal signal.



The submix bus selection is programmed for each voice in the Preset Edit, Amplifier screen (see “Amplifier/Filter” on page 341). These settings can be overwritten in the Multimode screen by changing the submix setting from “Voice” to “Sub 1, 2 or 3” which routes the preset on that MIDI channel to the selected submix bus.

In the screen below, MIDI channel 4 is programmed to the submix 1 bus. MIDI channels 2, 3 and 5 obey the submix routing as programmed in each voice.

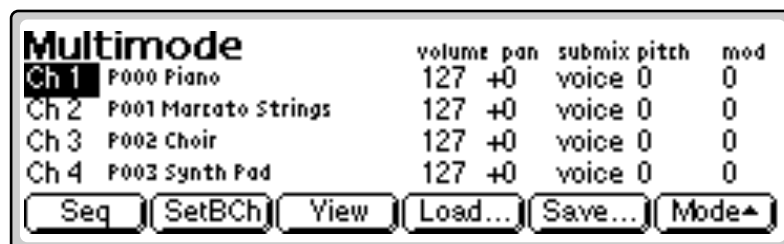

The submix bus routines are also available at the Sub Output jacks on the rear panel. Note that these outputs contain only dry signal. The Effects Processors are connected to the Main Outputs ONLY.

OUTPUT SECTION & EFFECTS PROCESSORS

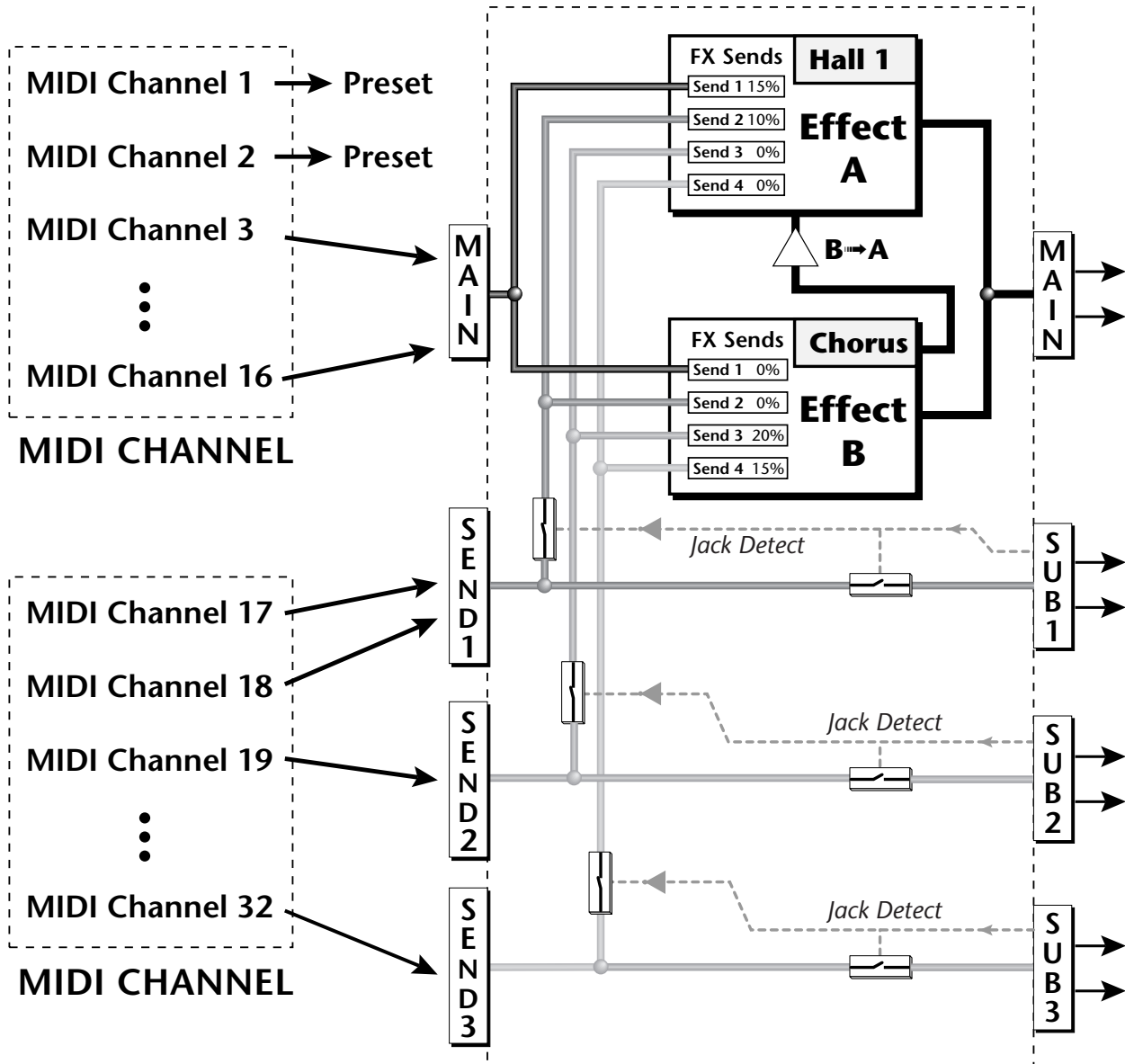

Individual Voices or MIDI channels can be routed to the four busses.
Note that the signal lines represent stereo signals

 The dry signal is removed from the main output even if only one plug is inserted into a submix jack.

If you insert a plug into a Sub Output jack, the dry signal from that bus is removed from the effects processor. This feature lets you have three dry mixes from the Sub Outputs and an “Effects Only” mix from the Main Outputs.

Effect B Into Effect A

The output of effects processor B can be routed into effect processor A. This connects the effects in series instead of their normal parallel configuration. Two effects connected in sequence sound very different than the same two effects in parallel. For example, a chorus patched through reverb can turn a bland string section into a lush wall of sound. The B->A amount can also be controlled for even more flexibility.

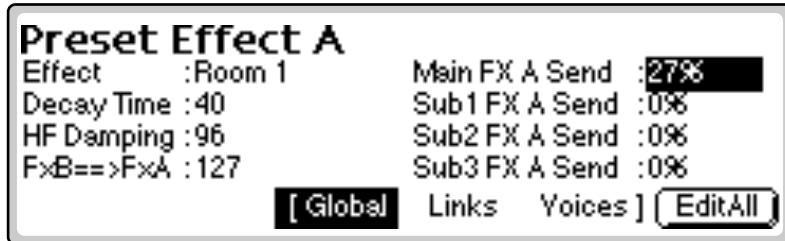

To Send the Output of Effect B through Effect A:

In this example, we send 100% of Effect B into Effect A.

1. Select the **Effect A** screen (in either the Master or Preset Edit menus).
2. Set the **B->A Amount** to 100%.
3. Turn the **Send Amounts** down to zero since we only want to hear the two effects in sequence.
4. Press the **Next** page button to select Effect B.
5. **Select an effect** and adjust the Main FX A Send percentage as desired.

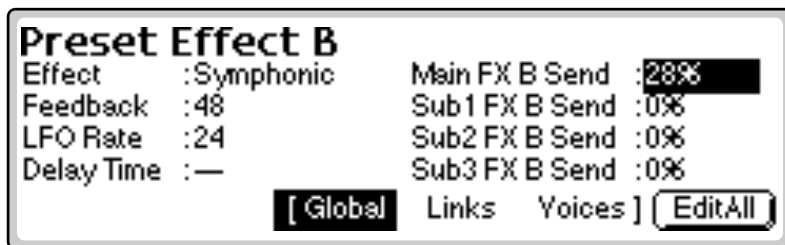

6. **Play the keyboard** and you should hear the B Effect running through Effect A. This patch is shown below.

 Because the amounts are Sends, we want to open the Main Send to Effect B, turn B->A up full and turn the Main Send to Effect A down to zero. This sends ALL of Effect B through Effect A.

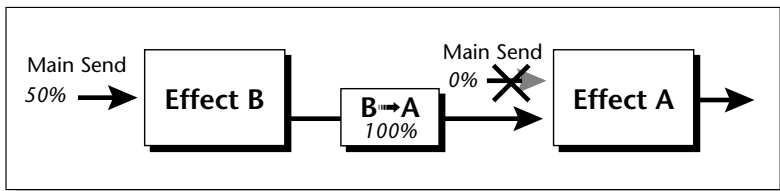

Three-way Effects Control

The effects processor controls are very flexible. The effects can be controlled in three different ways to suit your personal preference and to adapt to different situations.

1. Programmed as part of the preset when playing single presets (Omni or Poly Modes).
2. Programmed from the Master Effects Section when playing either single presets (preset Effect Type set to "Master") or when in Multimode.
3. Programmed from the designated control preset when in Multimode.

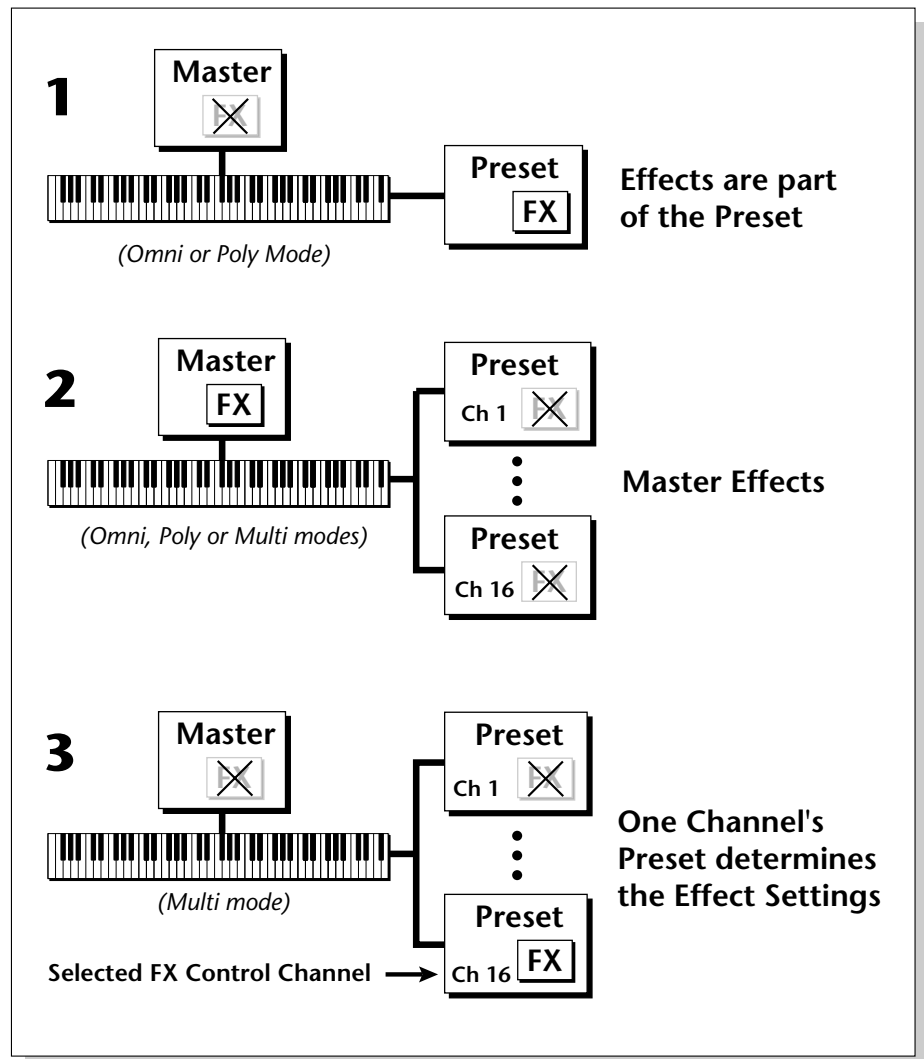

 If you try to access these screens from Multimode, a warning message will appear. Simply change back into Whole mode from the Mode screen on the main page.

Effects Programmed in the Preset

When playing single presets (*Whole = Omni or Poly modes*), the effects are normally programmed as part of the preset.

To Program the Effects as part of the Preset:

1. Press the **Preset Edit** button. The LED illuminates and the Preset Edit screen appears.

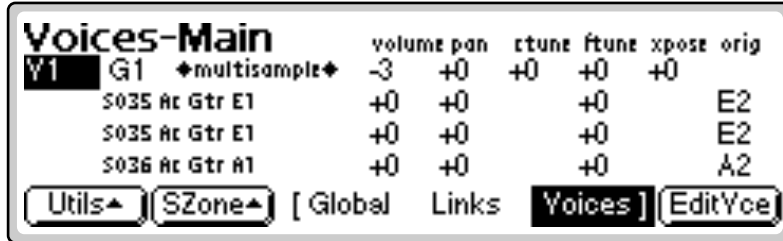

If you are in a screen where the “Global, Links, Voices” function keys are not visible, press the Exit button once.

2. Press the **Global** function key (F3). The Global menu appears.
3. Press the **Next page** button. The Preset Effect A menu appears.

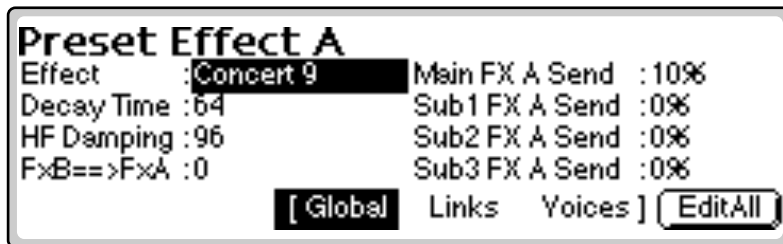

4. **Select an Effect.** Do not select the “Master Effects” setting as this will cause the Master effect settings to be used instead of the Preset Effect settings. Set the other effect parameters to your preference.
5. Press the **Next page** button again to go to the Preset Effect B menu.
6. **Save the bank.** The programmed effects setting will be saved along with the preset.

Master Effects

You might want the effects to be programmed on a global basis in Omni and Poly modes. You could choose your favorite reverb, for example, and have it applied to any preset you select.

To Program the Effects Globally for all Presets:

1. Press the **Preset Edit** button. The LED illuminates and the Preset Edit screen appears.

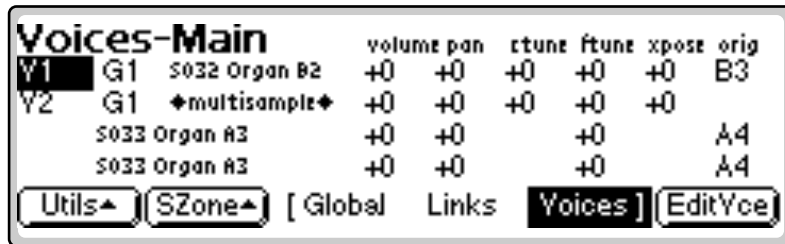

If you are in a screen where the “Global, Links, Voices” function keys are not visible, press the Exit button once.

2. Press the **Global** function key (F3). The Global menu appears.
3. Press the **Next page** button. The Preset Effect A menu appears.
4. **Set the Effect** to the “Default” setting which will cause the Master Effect settings to be used.
5. Press the **Next page** button again to go to the Preset Effect B menu. Set the Effect to the Default setting if you wish the Master settings to be used.
6. **Change each preset** in the bank to the Default setting if you want the Master Effect setting used on all presets.
7. **Save the bank.**

Using Master Effects Settings in Multimode

In Multimode, the two effects processors can be controlled from the Master Effects settings or they can follow the effects settings of the preset on a special MIDI channel. Because up to 32 presets can play at once in multimode, the effects cannot be programmed at the preset level. There are only two effects processors!

To Program the Effects Globally for all Presets:

1. Press the **Master** button. The LED illuminates and the Memory Statistics screen appears.

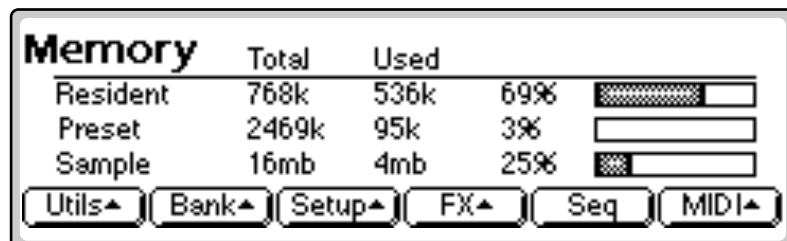

2. Press the **FX** function key. A second row of MIDI options appears.

3 - Effects
The Effects Sends

 A warning message appears if an effect routing other than "Master" is currently selected.

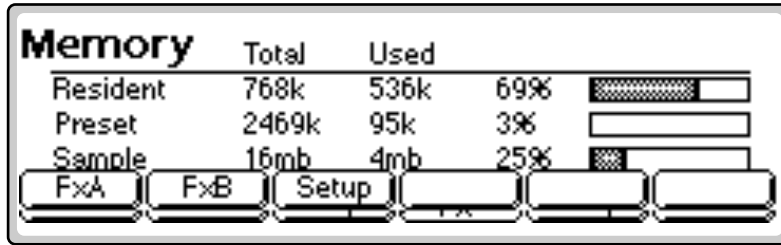

Memory	Total	Used	Percentage	Progress Bar
Resident	768k	536k	69%	
Preset	2469k	95k	3%	
Sample	16mb	4mb	25%	

Buttons: FxA, FxB, Setup, FX, Seq, MIDI

3. Press the **Setup** function key. The Effects Setup menu appears.



← PREV Master Effect B **Effects Setup** NEXT →

Effects Engine: Enabled

Multimode Effects Control: **master settings**

4. Move the cursor to the **Multimode Effects Control** field using the cursor buttons.
5. **Set the Effect Control channel to Master Settings** using the Data Entry Control or INC/DEC buttons.
6. Press the **Exit** button three times to save the settings and return to the main screen.

Using the Effects Channel Settings in Multimode

 The FX menu can be also be accessed by holding the Set/Shift button (decimal point) and pressing Assignable Key 2.

In Multimode, the effect settings can follow the effects settings of the preset on a special MIDI channel. You designate one MIDI channel as the "Multimode Effects Control Channel." When this is done, the effects processors follow the effects setting made in the preset assigned to this MIDI channel. This powerful feature lets you to change effects during a sequence.

 **To Set the Effects Control Channel:**

1. Press the **Master** button. The LED illuminates and the Memory Statistics screen appears.

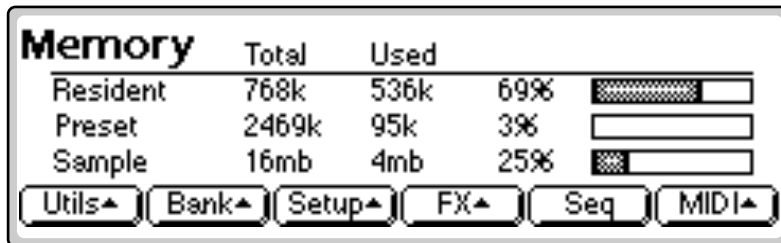

Memory	Total	Used	Percentage	Progress Bar
Resident	768k	536k	69%	
Preset	2469k	95k	3%	
Sample	16mb	4mb	25%	

Buttons: Utils▲, Bank▲, Setup▲, FX▲, Seq, MIDI▲

2. Press the FX function key. A second row of MIDI options appears.
3. Press the **Setup** function key. The Effects Setup menu appears.

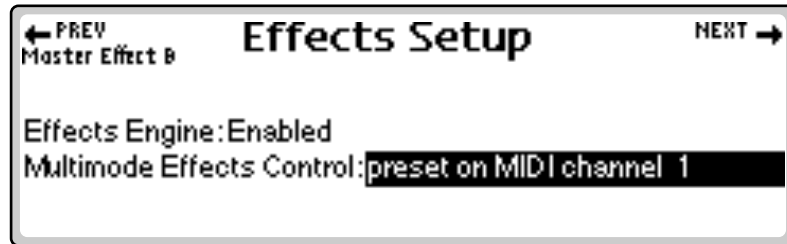

4. Move the cursor to the **Multimode Effect Control** field using the cursor buttons.
5. **Set the Effect Control channel** using the Data Entry Control or INC/DEC buttons.
6. Press the Exit button three times to save the settings and return to the main screen.

Effects Bypass

This control provides a true bypass of the effects engine. Bypass is a useful feature if you are using external effects at the mixing console and want to turn the effects off for all presets.

To Bypass the Effects:

1. Press the **Master** button. The LED illuminates and the Memory Statistics screen appears.

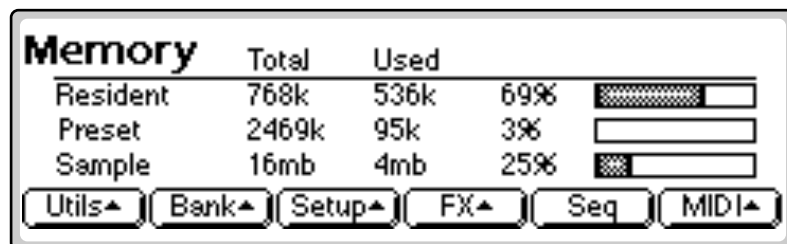

2. Press the FX function key (F4). A second row of Effects options appears.

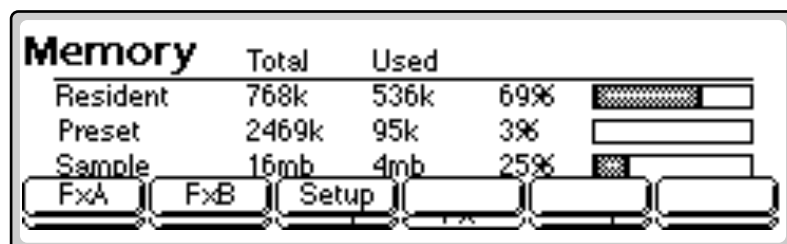

3. Press the **Setup** function key (F3). The Effects Setup screen appears.



4. **Enable or disable the Effects Engine** using the Data Entry Control or INC/DEC buttons.
5. Press the Exit button three times to save the settings and return to the main screen.

Effect Descriptions

A EFFECT TYPES

Room 1-3	Hall 1 & 2	Plate
Delay	Panning Delay	Multitap 1
Multitap Pan	3 Tap	3 Tap Pan
Soft Room	Warm Room	Perfect Room
Tiled Room	Hard Plate	Warm Hall
Spacious Hall	Bright Hall	Bright Hall Pan
Bright Plate	BBall Court	Gymnasium
Cavern	Concert 9	Concert 10 Pan
Reverse Gate	Gate 2	Gate Pan
Concert 11	Medium Concert	Large Concert
Large Concert Pan	Canyon	DelayVerb 1-3
DelayVerb 4-5 Pan	DelayVerb 6-9	

B EFFECT TYPES

Chorus 1-5	Doubling	Slapback
Flange 1-7	Big Chorus	Symphonic
Ensemble	Delay	Delay Stereo 1 & 2
Panning Delay	Delay Chorus	Pan Delay Chorus 1 & 2
Dual Tap 1/3	Dual Tap 1/4	Vibrato
Distortion 1 & 2	Distorted Flange	Distorted Chorus
Distorted Double		

Reverb

Reverberation is a simulation of a natural space such as a room or hall. The reverb effects simulate various halls, rooms and reverberation plates. In addition, there are several other reverb effects such as Gated Reverbs, Multi Tap (early reflections), Delay and Panning effects. Reverb effects have two adjustable parameters- Decay Time and High Frequency Damping.

Decay time defines the time it takes for the reflected sound from the room to decay or die away. The diagram below shows a generalized reverberation envelope.

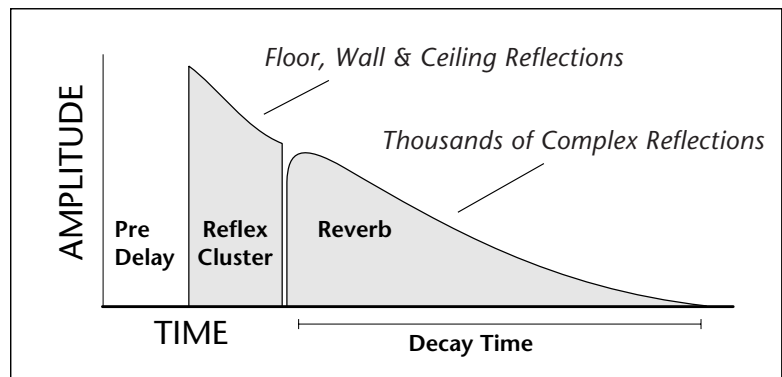

After an initial pre-delay period, the echoes from the closest walls or ceiling are heard. These first echoes or the early reflection cluster, vary greatly depending on the type of room. Roughly 20 milliseconds after the early reflection cluster, the actual reverberation begins and decays according to the time set by the Decay Time parameter.

High frequency energy tends to fade away first as a sound is dissipated in a room. The High Frequency Damping parameter allows you adjust the amount of high frequency damping and thus change the characteristics of the room. Rooms with smooth, hard surfaces are more reflective and have less high frequency damping. Rooms filled with sound absorbing materials such as curtains or people have more high frequency damping.

General Descriptions of Reverb

Room programs simulate small rooms with high frequency absorption caused by drapes and furniture.

Plates simulate plate type reverbs with their tight, dense early reflections and sharp reverb buildup.

Hall programs recreate the open, spacious ambience of large concert halls.

Gated Reverbs add ambience only while the original signal is still sounding. As soon as the signal falls below a threshold, the reverb is automatically cut off.

Delay programs can be used to create echo and doubling effects.

Multi Taps consist of the reflection cluster only without the reverb decay.

Chorus

The function of a chorus device is to thicken the sound or to make one voice sound like many. The way to achieve the effect is to mix one or more delayed versions of the signal with the original. The delay times used are too short to be perceived as an echo, but long enough so that comb filtering does not occur. In addition, the delay time is varied via a low frequency oscillator to simulate the random differences which occur when multiple instruments are playing together. A slight amount of feedback improves the effect by creating multiple images of the sound as it recirculates again and again.

All the choruses are true stereo using two separate delay lines controlled by a single set of controls. The delay times are slightly different for each channel and the LFO phase is inverted on one channel to help contribute to the overall chorus effect. The LFO Rate and Depth settings are critical to achieving a realistic effect, with faster LFO, rates generally requiring less LFO amount and vice-versa.

Doubling

When a copy of a sound delayed by about 26 milliseconds is added back with the original, two audio images can be perceived by the brain. When the delayed image is slightly varied or modulated, the illusion of two voices is created.

Slapback

Slapback is a single short echo in the range of 50-60 milliseconds. A sound delayed by this length of time is perceived as a discrete and separate image which is useful for a thickening effect or as a pre-delay for reverb simulating a hard, reflective surface such as a gymnasium wall.

Stereo Flanger

A flanger consists of a short audio delay line whose output is mixed together with the original signal. Mixing the delayed and original signals results in multiple frequency cancellations called a comb filter. Since the flanger is a type of filter, it works best with harmonically rich sounds.

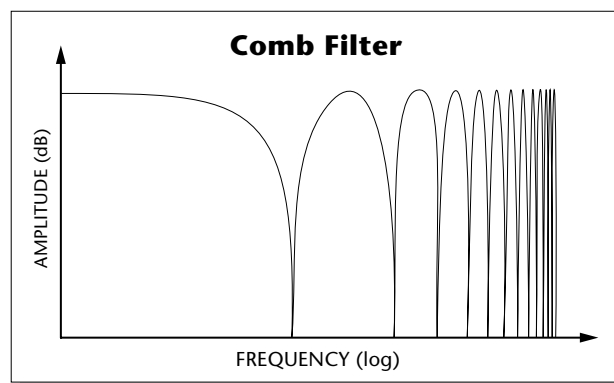

Flanging was originally created using two tape recorders playing identical recordings. By exactly synchronizing the two decks and then slowing the speed of one by grasping the tape reel flanges, the flanging effect was born.

The flanger is a stereo device consisting of two separate delay lines controlled by a single set of controls. A Low Frequency Oscillator (LFO) varies this initial delay setting, changing the frequency of the notches and adding animation to the sound. LFO Rate controls the rate of change and LFO Depth controls how much the LFO changes the delay.

The Feedback control sends some of the delayed signal through the delay line again. When feedback is used the comb filter notches are deepened.

Delay

Delay is an effect which can be used for doubling, reverb pre-delay, or echoes. Delay Time is variable from 0-635 mS and controls the time between echoes and Feedback and determines how long the echoes continue sounding. "Infinite" delay effects are also possible without the risk of runaway.

Stereo Delay

Similar to delay except that the delay line outputs a stereo signal from the mono input. The two output signals are a few milliseconds apart to create a stereo image. The delay times are variable from 0-635 mS.

Panning Delay

A panning delay is similar to the normal delay lines except that the echoes bounce back and forth between the two stereo speakers.

Dual Tap

These are delay lines where the signal is "tapped off" at two unevenly spaced locations. When feedback is used, multiple complex echoes are produced. The fraction in the name (i.e. 1/3, 1/4) refers to the distance between the taps.

Vibrato

Basically, this is a delay line modulated by an LFO, but with none of the original signal added in. The LFO modulation creates a Doppler shift and a resultant cyclical pitch shift. The vibrato created in this manner sounds very different than vibrato created by frequency modulating the sample.

Distortion

Distortion uses a technique called "soft-clipping" to create additional harmonics in the signal. As the level increases, the top of the waveform becomes somewhat squared. As the level increases further, it transforms into a true square wave.

3 - Effects

Sequencer

4

4 - Sequencer

Sequence Manage



See Chapter 1: The Basics, for step by step instructions on how to create a sequence.



EOS 3 contains a powerful 48-track onboard sequencer which is always ready and available to capture your musical ideas. The sequencer's easy to use interface lets you lay down tracks almost as fast as you can play them. After recording, you can use its powerful editing capabilities to rearrange and polish your creation in almost any imaginable way. Editing is easy, thanks to intuitive Copy and Paste style editing and an impressive array of tools which allow you to: Quantize, Transpose, Scale Velocity or Rechannelize Tracks. You can also Channelize or Quantize MIDI data while recording.

Program Changes, Pan Position, Initial Volume, Submix, Tempo, Controller Changes and SysEx data can all be stored with the sequence. You can record and save up to 50 sequences along with each EOS bank. If Flash RAM is installed (ROM or Flash RAM upgrade), you can save 50 additional sequences to Flash Memory.

Sequencer note capacity is dependent upon the amount of CPU memory installed and how much you have allocated to sequences. As an example, over 400,000 notes can be stored if you have 4 MB of preset RAM. About 97,000 notes can be stored if you have 1 MB of preset RAM.

Sequences can be copied, renamed, and are easily imported or exported as Standard MIDI Files or E-mu's EIV format. As a bonus feature, the virtual "Jukebox" lets you link up to 7 sequences and play them back in any order.

Note

When sequencing on a Rack Emulator with dual MIDI ports, you **MUST** use **Port A** for your MIDI input. Port B does not get routed to the sequencer.

☞ To Enter the Sequence Manage Menu:

- Hold the Decimal Point key and press Assignable Key 1.
- On the E4K or E-Synth keyboard, press the Sequencer key.



The Sequence Manage menu accesses the following functions. The memory usage and number of tracks contained in the current sequence are displayed.

Sequence Select. Use the Data Entry Control, INC/DEC keys, Page keys or Left/Right Cursor keys to select sequences.

Utilities. Contains Erase, Copy and Jukebox functions.

Name. Allows you to name a sequence.

Export. This function exports the currently selected sequence as a Standard MIDI File or in EIV Format.

Loop. The sequence can be set to repeat continuously or to stop when it reaches the end.

Edit. The Edit function key toggles back and forth between the main Sequencer functions and the Sequence edit screen and functions.

Menu/Transport. Toggles between the Manager function keys and the Transport Control Keys.

☞ To Change the Current Sequence:

1. From the Sequence Manage screen, use the Data Entry Control or INC/DEC keys to select a sequence location.
 - An Untitled Sequence is one that has been recorded but not yet named.
 - An Empty Sequence is an empty sequence location ready to be recorded.

 **To Load a Sequence into the Bank**

1. Enter the **Disk** submodule.
2. Press the **Browse** function key (F2).

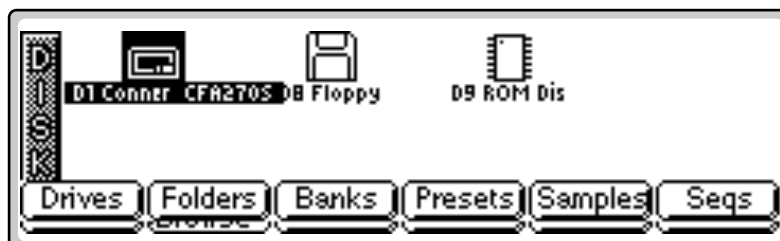

3. Select **Drives** (F1).
4. **Select the desired disk drive** using the cursor keys.
5. Press the **Browse** function key (F2).
6. Select **Banks** (F3).
7. Select the desired **Bank** using the cursor keys.
8. Press the **Browse** function key again (F2).
9. Press the **Seqs** function key (F6). Any sequences resident in the selected bank are shown.



10. **Select a sequence** to be loaded using the cursor keys.
11. Press the **Load** function key (F4).
12. **Select the destination location** and press **OK** (F6). The sequence is loaded into the bank.
13. **Repeat steps 5-12** to load additional sequences.

 **To Save a Sequence:**

Sequences are saved along with the bank.

 **To Save the Bank and its Sequences**

1. Press **Save** (F5) from the main screen of EOS.
2. **Choose a location** and press **OK** (F6). The default location is the current bank. Press **OK** to overwrite.

 You can also **Copy Sequences** to Preset Flash memory, designated by the prefix "z".

 To edit a Flash sequence, first Copy it into a RAM location (00-49).

 If a Standard MIDI File is too large to fit into memory, try re-recording it from an external sequencer into the Emulator's MIDI In port. Files generally use MUCH less memory when imported this way.

 **To Save a Sequence into Flash Memory:**

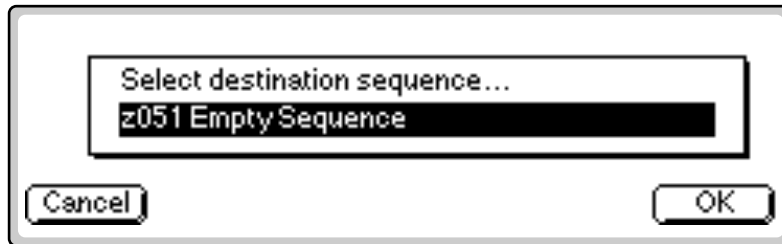

1. From the Sequence Manage screen, press **Utils**.
2. Press the **Copy** function key. The screen shown above appears.
3. **Select a sequence location.** If you have Flash ROM or Flash RAM installed, 50 flash locations (z050-z099) are provided to store your sequences.
4. Press **OK (F6)**. The sequence is stored in Flash Memory.

Recording MIDI SysEx

The Sequencer can also function as a MIDI data filer to record System Exclusive messages such as control data or programs for another MIDI instrument.

 **To Record a SysEx Message:**

1. **Connect** MIDI Out of the external device to MIDI In of the Emulator.
2. **Start** the **Sequencer** recording and **send the SysEx data**.
3. **Stop** the Sequencer when the transmission is finished.

 **To Play Back a SysEx Message:**

- Simply **play back the sequence** with MIDI Out of the Emulator connected to MIDI In on the receiving device.

Standard MIDI files

The Sequencer can load and play Standard MIDI File sequences (type 0 or 1). Sequence files should conform to PC DOS format using a DOS high-density, formatted disk and using the following format for the file name: 12345678.MID (up to eight characters followed by ".MID"). It is important to note that Standard MIDI Files appear as Banks, NOT as sequences in the Sequence Browser.

 **To Load a Standard MIDI File from Floppy Disk:**

1. **Insert a DOS formatted HD (1.44MB) floppy disk** containing the Standard MIDI Files into the floppy disk drive.
2. From the Disk Browser, **select the floppy drive**.

 Plan your tracks **BEFORE** exporting from the computer. If you've done the kick, snare and hi-hat on separate tracks, combine them before exporting.

 A MIDI file cannot have more than 48 tracks or it won't load.



 If the file name doesn't conform to the proper format, the question mark icon shown above appears. Rename the file according to the file name requirement using the "Name Bank" function. The icon should now look normal and the sequence should merge properly.

3. Press **Browse** again and select **Banks**. The MIDI sequences appears as banks.
4. Press the **Load** function key (F4). A pop up dialog box appears warning you that loading will destroy the resident bank.
5. Press the **Merge** key. The selected sequence will be merged into the current bank, and will be placed in the first empty sequence location.
6. Press **OK** to load the selected sequence or **Cancel** to stop the operation.

Important Information for Loading Standard MIDI Files

- Use PC DOS formatted diskettes to load from floppy. Disks can be formatted on either the Mac or PC.
- To be readable, the file **MUST** have 0-8 characters, then a period, then "MID".
- Regardless of channels, only 48 tracks can be in the MIDI file or it won't load.

To Play Standard MIDI Files:

1. Follow the instructions above to load an SMF.
2. Select the **Sequence** from the Sequence Manage menu.
3. Press **Play** (Menu/Transport) to play the sequence.

Name Sequence

You can give your sequences names of up to 16 characters.

To Name a Sequence:

1. From the Sequence Manage menu, **select the sequence** you wish to name or rename using the Data Entry Control or the INC/DEC keys.
2. Press the **Name** function key (F3). A pop up dialog box appears asking you to enter the new preset name.

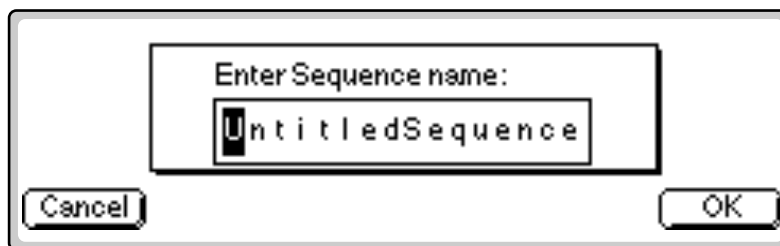

3. **Name the sequence.** Select letters using the numeric keys, Data Entry Control, INC/DEC keys or using an ASCII keyboard.
4. Press the **Right Cursor** key to advance the cursor to the next letter field. The up cursor key adds a space and the down cursor key deletes a space.
5. Press **OK** (F6) to confirm the operation or **Cancel** (F1) to stop.

Export

This function allows you to export a sequence as an EIV bank or as a Standard MIDI File. Standard MIDI Files or SMFs are compatible with most computer-based sequencers. EOS uses the MS-DOS format on its floppy disks to facilitate easy file transfers between either IBM or Apple computers.

Exporting a sequence as an EIV bank allows you to transfer sequences between two EOS machines and also allows you to combine sequences from different banks.

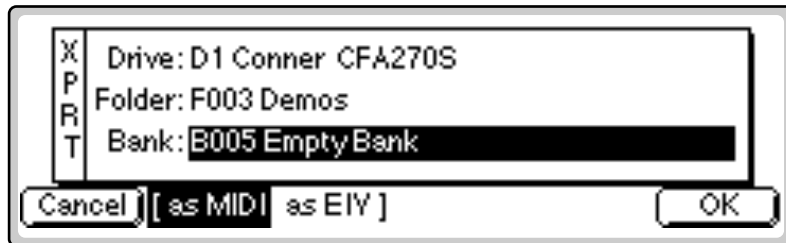

To Export a Sequence:

1. From the Sequence Manage menu, **select the sequence** you wish to export using the Data Entry Control or the INC/DEC keys.
2. Press the **Export** function key (F5). The pop up dialog box shown above appears.
3. **Select the destination** for the exported sequence by using the cursor keys to select the field and the Data Entry Control or INC/DEC keys to change the selection. If you are exporting to a floppy disk, insert a DOS formatted disk into the drive.
4. Select either **MIDI** (Standard MIDI File) or **EIV** as the file type.
5. Press **OK** to export the sequence or **Cancel** to cancel the operation.

Transport Controls

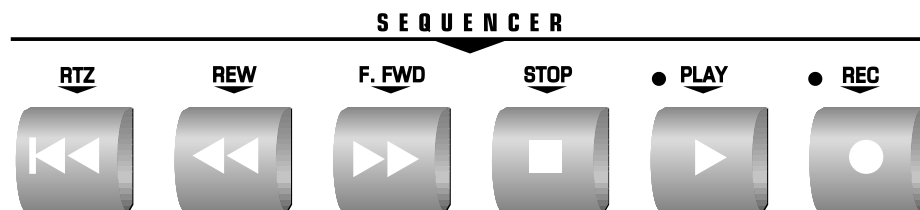

Transport Controls on E4K or E-Synth Keyboard Panel. These controls should look familiar to you. They operate exactly like the controls on a cassette deck or any other recorder. The E4K and E-Synth Keyboard have sequencer transport controls located right on the front panel.

Function key Sequencer Transport Controls.

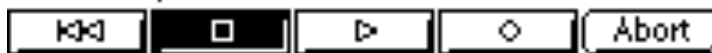

All EOS machines have a detailed sequencer transport screen located in the Sequence Manage module.

To Access the Transport Buttons:

- From the Sequence Manage screen, **press MGR/TRNSPT (F6).**

The Transport controls perform the following functions. Note that not all functions are available from either set of transport controls.

RETURN TO ZERO. Resets the sequence to the beginning.

STOP. Immediately stops recording or playback.

REWIND. Moves quickly back through the sequence.

F. FORWARD. Moves quickly forward through the sequence.

PLAY. Starts the sequence playing from its current position.

RECORD. Initiates recording (when pressed in combination with Play).

ABORT. Stops and erases the current recording.

Sequencer Utilities

The Erase, Copy, Memory and Jukebox functions are located in the Sequencer Utilities submenu.

Erase: This function allows you to erase a sequence.

Copy: Allows you to copy the current sequence to another sequence location.

Jukebox: The jukebox allows you to link up to seven sequences and play them back one at a time.

Erase

This utility erases an entire sequence.

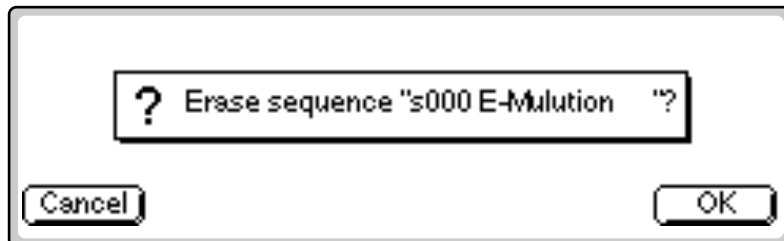

To Erase the Sequence:

1. From the Sequence Manage menu, **select the sequence** you wish to erase using the Data Entry Control or the INC/DEC keys.
2. Press the **Utils** function key (F1).
3. Press the **Erase** key (F1). A pop up dialog box appears asking you if you really want to erase the sequence.
4. Press **OK** (F6) to erase the sequence or **Cancel** (F1) to cancel the operation.

 Sequences can be copied to Preset Flash memory locations x050 - z099.

 **Caution:** Copying a sequence will overwrite the sequence (if any) in the destination location.

Copy Sequence

The current sequence can be copied to any of the other sequence locations.

To Copy a Sequence:

1. From the Sequence Manage menu, **select the sequence** you wish to copy using the Data Entry Control or the INC/DEC keys.
2. Press the **Utils** function key (F1).
3. Press the **Copy** function key (F2). A pop up dialog box appears asking you to select the destination sequence location.

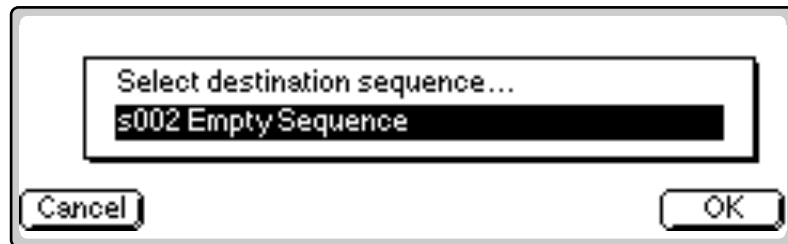

4. **Select the destination sequence** location using the numeric keys, Data Entry Control, INC/DEC keys or using an ASCII keyboard.
5. Press **OK** (F6) to confirm the operation or **Cancel** (F1) to cancel the operation.

Sequencer Memory

This screen displays the sequencer memory status. You can enable this screen while recording to monitor the sequence memory usage.

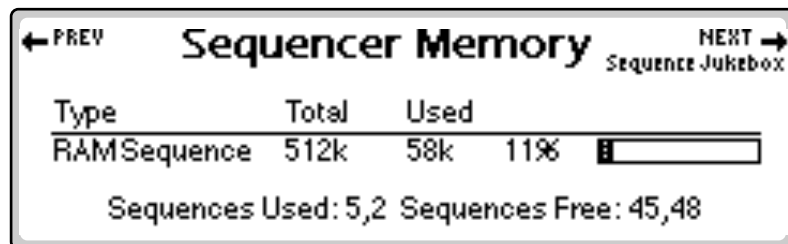

To Check the Sequencer Memory:

1. From the Sequence Manage menu, **select a sequence** using the Data Entry Control or the INC/DEC keys.
2. Press the **Utils** function key (F1).
3. Press the **Memory** function key (F5). A pop up dialog box appears displaying the amount of memory used by the current sequence.

Jukebox

The jukebox lets you play up to seven sequences in series. After the last selection is played, the jukebox will loop back to the first sequence. The jukebox starts on the current selection. If you move the cursor to a different selection, it will jump to that selection after finishing the current selection. You **MUST** be in the Jukebox screen for it to operate.

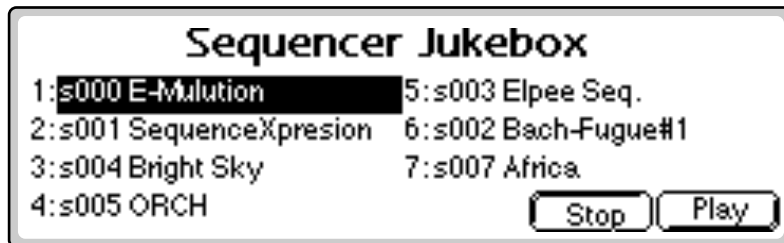

To Play Sequences from the Jukebox:

1. From the Sequence Manage menu, press the **Utils** function key (F1).
2. Press the **Jukebox** function key (F6). The screen shown above appears.
3. **Select the desired sequence** order using the cursor keys and Data Entry Control or INC/DEC keys.
4. Press **Play** (F6) to begin playing the jukebox selections. You **MUST** be in the Jukebox screen for it to operate.
5. Press **Stop** (F5) to stop playing the jukebox selections.
6. Press **Exit** to return to the Sequence Manage screen.

Sequence Edit

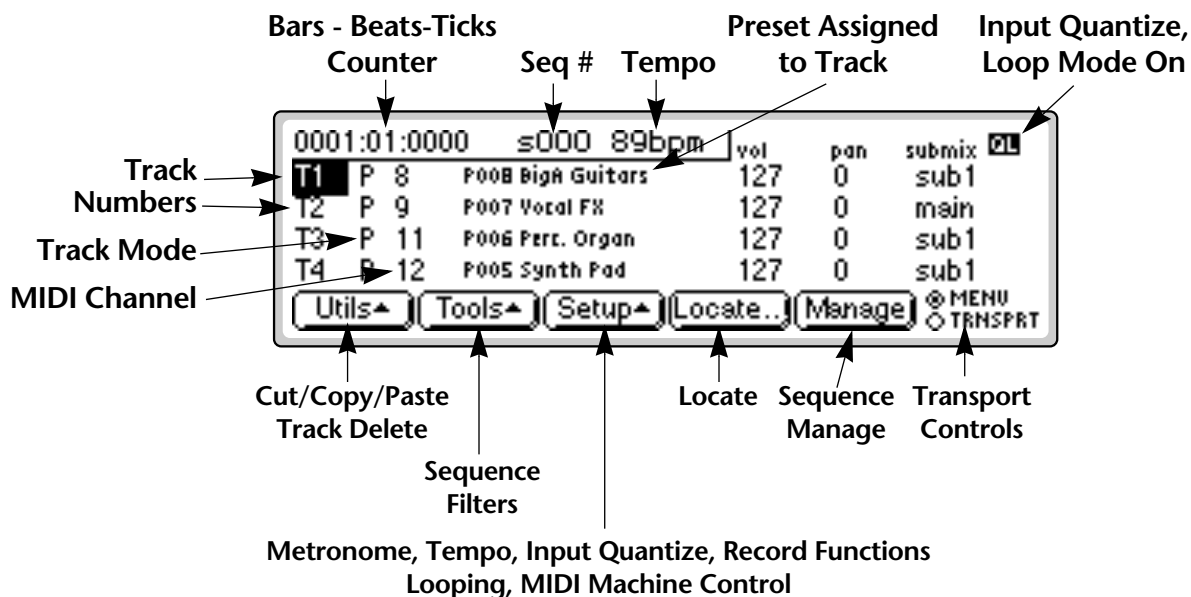

See Chapter 1: The Basics, for step by step instructions on creating a sequence.

- Multitimbral Recording:**
1. Be in Multimode.
 2. Set Track Mode to "R".
 3. Set the MIDI channel to @1 (or other channel).
 4. Select a Preset.
 5. Select Transport.
 6. Press Record, then Play.
 7. Start Playing!
 8. Repeat for Track 2.

The Sequence Edit screen is so versatile that you will probably do ALL your sequencing from this page! It contains all the features that allow you to edit and modify your sequence once it has been recorded.

Use the up/down cursor keys to select between the 48 tracks. Use the left/right cursor keys to select parameters such as the preset assigned to the track, MIDI channel of the track (for controlling external MIDI devices), volume of the track, pan position of the track and length of the track in bars/beats and ticks. Tracks can be set up to record, play back, solo and mute, and presets can be changed and rearranged.

Pressing the Menu/Transport key (F6) allows you to bring up the transport controls at any time.

Tracks can be rearranged using the cut, copy and paste utilities and filter tools. The Setup submenu contains setup functions such as metronome, tempo, input quantize and count-in functions.

To Access the Sequence Edit Menu:

1. Hold the **Decimal Point** key and press **Assignable Key 1**. On the E4K or E-Synth keyboard, press the Sequencer key.
2. Press the **Edit** key (F5). The Sequencer Edit screen shown on the previous page appears.



A track can contain multiple channels, whether recorded or imported via MIDI file.

Regardless of channels, a MIDI file cannot have more than 48 tracks or it won't load.



The counter display may slow when large amounts of data are being recorded because it is being given a low priority by the computer.

This does not affect the accuracy of the recording.

The Sequence Edit Screen

Track Mode

This field allows you to change the track status of the 48 sequencer tracks. Several track status options are available.

P:	Play: Plays the track.
M:	Mute: Temporarily silences the track without erasing it.
S:	Solo: Solo silences all other tracks and plays only those tracks which are in solo mode.
R:	Record: Puts the track in record mode.
- :	Empty: Indicates that the track is empty.
o:	Overdub: Allows you to record additional data onto the track.
r:	Re-record: New data entered will replace existing data between the point where the sequence is started and stopped.

Track Numbers

The track numbers are listed on the left side of the Edit display. Only four tracks are shown at once. Press the up/down cursor keys to access other tracks.

Counter Display

The sequence counter shows the current position of the sequence in bars-beats-ticks (there are 480 ticks in a beat). This display helps you locate your current position in the song. See the Clock function (Setup, Clock) for more information about the counter.

Tempo Display

The tempo displays the current tempo of the song. See the Clock function (Setup, Clock) for additional information about the Tempo display.

Track → Preset

This field allows you to change the preset assigned to each track. Preset changes made during recording will be displayed in this field.

MIDI Channel Modes

This field allows you to set the MIDI channel which will be recorded on each track.

rcvd:	Received: Data on any received MIDI channels will be recorded on the selected track. EOS tracks can contain data on multiple MIDI channels.
@1:	At Channel: All MIDI data will be rechannelized to the selected channel. This mode ensures that you will record on only one MIDI channel per track.
1:	Single Channel, 1-16: Indicates that data on a single MIDI channel (the one displayed) has been recorded onto the track.
M:	Multiple Channel: Indicates that multiple MIDI channels have been recorded on the track.

 *Overdub mode is useful for making real-time edits to the Volume, Pan and Submix of the track.*

 *By creating special sequences containing only Initial Track State information, you can store Multimode preset/channel maps. Simply start and stop the special sequence to load a new multimap.*

1. Put a track into Record and move the pitch or mod. wheel.
2. Setup the Initial Track State info for the track.

 **Caution:** *If you copy the first measure of a sequence that has Initial Track States programmed, the initial parameters will also be copied.*

Volume - Pan - Submix

These fields display and allow you to change the volume, pan and submix routing for each track.

The Initial Track State Screen

This screen allows you to set the initial Preset, Volume, Pan Position and Submix for each of the 48 tracks. Setting the initial parameters ensures that the correct presets are selected when your sequence starts.



Initial Track State				vol	pan	submix
T1	1178 Saw Lead	116	15	main		
T2	1101 Bass & E.Guitar	104	-14	sub1		
T3	1234 Kick & Snares	100	-	-		
T4	154 SynthVoiceSweep	117	-	-		

Tempo.. [] [] [] []  MENU
 TRANSPRT

To Access the Initial Track State Screen:

1. To modify the Initial Track State, you must have with a recorded sequence.
2. From the Sequence Edit screen, press the **Page Right** key. The Initial Track State screen shown above appears.
3. Adjust the initial Preset, Volume, Pan Position and Submix as desired for each recorded track.
4. To remove Initial Track State information from a track, **Cut the first Tick** from the track. This is where the Initial Track State info is stored.

4 - Sequencer Initial Tempo



To remove initial track state information, Delete the first Tick of the sequence.

Initial Tempo

This screen lets you program the Initial Tempo and Meter of a song. The tempo track and meter settings are stored with the song, but they can be overridden by setting the tempo control (located in the Sequencer Clock menu) to Screen Value.

To Set the Initial Tempo:

1. From the Sequence Edit screen, press the **Page Right** key. The Initial Track State screen appears.
2. Press the **Tempo** function key (F1). The following window pops up on the screen.



3. Set the **Initial Tempo** and **Meter**.
4. Press **Update** to lock in the new tempo and meter or **Cancel** to cancel the operation.

Editing: Cut, Copy & Paste

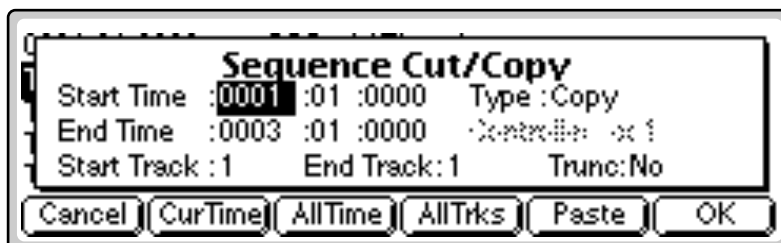

Cut/Copy/Erase

A section of a track (or an entire track) can be cut out, or copied and held on the digital clipboard, and then Pasted to another section in any track.

There are several types of Cut and Copy functions available.

Cut. Cuts the selected section to the clipboard and moves the following data backward to fill the space in the cut section.

Copy. Copies the selected section to the clipboard and leaves the original section unaffected.

Erase All. Erases the selected section and leaves a blank space in the selected section.

Erase Notes. Erases only the note data in the selected section.

Erase All Controls. Erases only the controller data in the selected section.

Erase One Control. Erases only the controller data on the selected controller channel in the selected section.

Delete. Erases the selected section and moves the following data backward to fill the space in the deleted section.

Truncate. Yes - Any Note-Offs occurring after the selected End Time will be truncated to the selected End Time. The note length may not be preserved.
No - The Note-Off will occur as it was recorded, even if this time falls outside the selected End Time. The note length will be preserved.

 For more information about Copy and Paste, see Chapter 6: Sample Edit.

 **To Cut/Copy/Erase:**

1. From the Sequence Manage screen, press the **Edit** function key (F3).
2. Press the **Utils** function key (F1). A second row of function keys appears.
3. Press the **Cut/Copy** function key (F1). The Cut/Copy menu shown above appears.
4. Select the **Start** and **End time** in bars/beats/ticks using the cursor keys to select the field and the Data Entry Control or INC/DEC keys to change the selection.
 - Press the **All Time** function key to select everything in the selected track(s).
 - Press the function key to select the current location as the Start and End Times.
5. **Select the range of tracks to be cut or copied.**
 - Press the **All Trks** function key to select all tracks.
6. Turn **Truncate** (*note-off*) On or Off.
7. If you have selected Erase One Control, **select the controller number.**
8. Press **OK** to proceed or **Cancel** to cancel the operation.
9. To go directly to the Paste operation, press **Paste**.

Note Erase

EOS contains a quick and handy way to erase notes from a recorded track. Only one note can be erased at a time. If more than one note is held, the last note pressed will be used for the erase.

Conditions: *For Note Erase to work...*

- You must be in **Record-Overdub** mode.
- **Loop Region** must be **On**.
- The sequence must be on the **second** or **subsequent loop**.

The E will appear in the display **ONLY** if the above conditions are met.

 **To Use Note Erase Mode:**

1. While playing back the sequence in **Record-Overdub** and **Loop** mode, **press and hold** the **Set/Shift** key. An "E" appears in the Edit screen.
2. **Play the note** you wish to erase on the keyboard.
3. **Release the note** to stop erasing.
4. **Release the Set** key to go out of Erase mode.

Cut

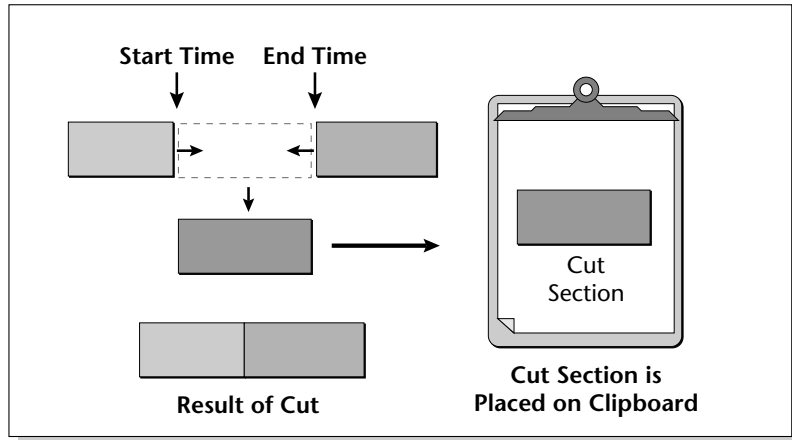

Erase

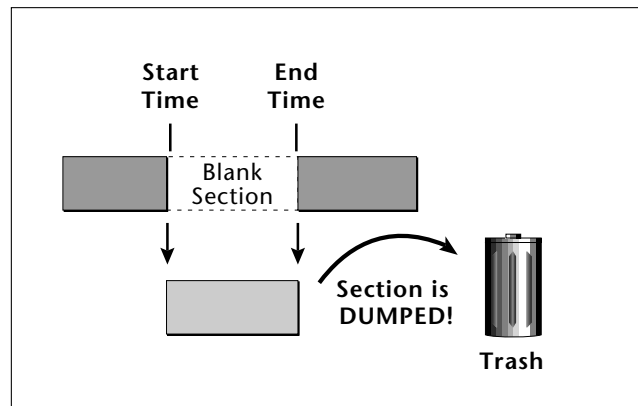

Delete

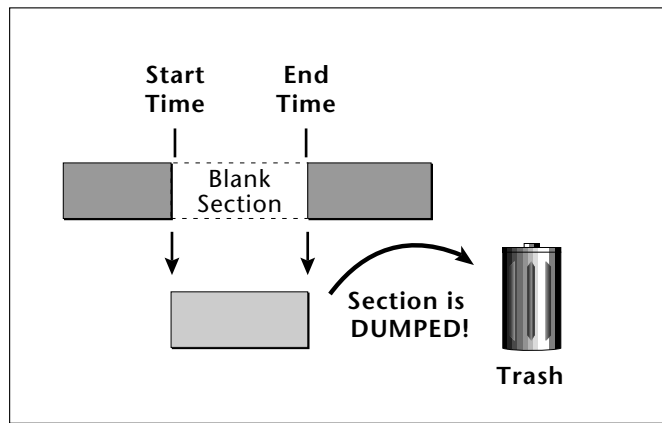

Paste

Once a section of a track (or entire track) has been cut or copied to the clipboard, it can be Pasted to a destination. The copied section can be placed on any track and can be placed anywhere on the track using the Start Time parameter.

If multiple tracks have been cut or copied to the clipboard, they will be pasted to consecutive tracks between the start and end track numbers specified in the Paste window.

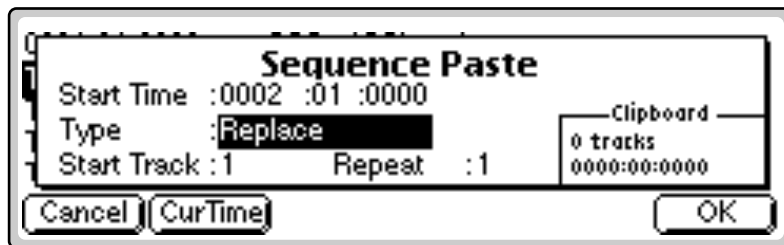

There are three replacement modes which determine how the clipboard data will be pasted onto the track.

Insert. This mode will open up a region in the destination segment at the selected Start Point and will move the data after the Start Point ahead to make room for the clipboard data to be inserted.

Replace. In this mode, the clipboard data will be pasted to the destination track at the selected Start Point and will overwrite any data in that section of the track.

Merge. In this mode, the clipboard data will be combined with data in the destination track.

Repeat. Designed to be used in conjunction with **Insert** mode, this feature will Paste the clipboard contents from 1 to 127 times, lengthening the sequence.

To Paste a Section:

1. From the main Sequencer screen, press the **Edit** function key (F5).
2. Press the **Utils** function key (F1). A second row of function keys appears.
3. Press the **Paste** function key (F2). The Paste menu appears.
4. Select the **Start Time** in bars/beats/ticks.
 - Press the **CurTime** function key to select the current location as the Start Time.
5. Select the **Type of Paste**. Your choices are: Insert, Replace, or Merge.



The clipboard may contain data on a different MIDI channel.



Using the Repeat feature in Merge mode may clog your sequence.

6. Select the **Start Track** and **End Track** number.
7. Set the number of **Repeats** (*should be set to 1 except in Insert mode*).
8. Press **OK** to paste the section or **Cancel** to cancel the operation.
 - Press the **Repeat** function key to paste the selection and return to the Paste screen ready to do it again.

Insert

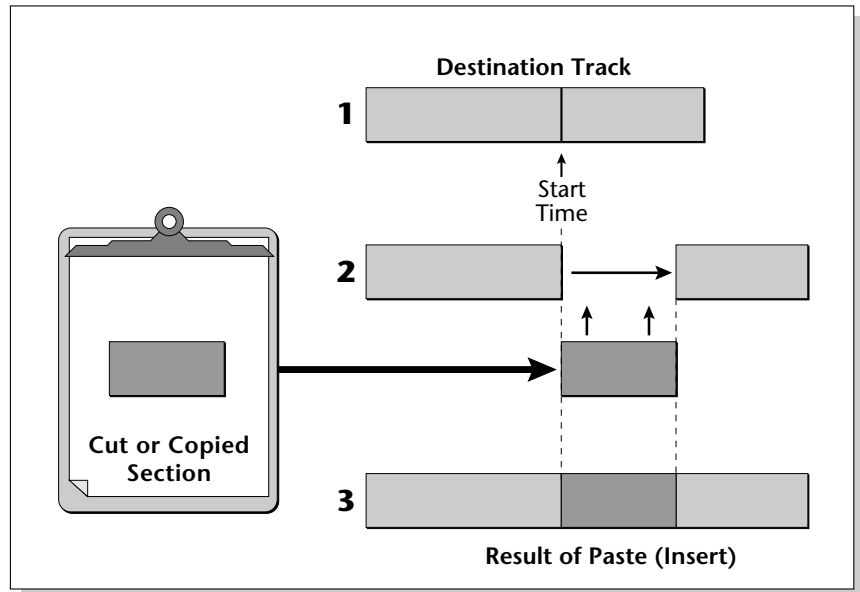

Replace

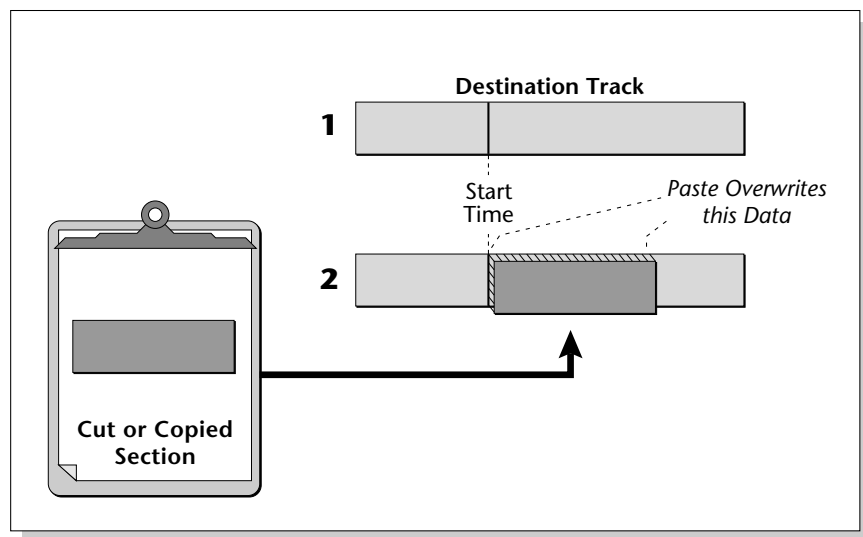

Track Delete

Any track (or multiple tracks) can be permanently erased.



To Delete Tracks:

1. From the main Sequencer screen, press the **Edit** function key (F3).
2. Press the **Utils** function key (F1). A second row of function keys appears.
3. Press the **TrkDel** function key (F3). The Track Delete menu shown above appears.
4. Select the **tracks** to be deleted using the Start and End Track parameters.
 - Press the **All Trks** function key to select all tracks.
5. Press **OK** to delete the track(s) or **Cancel** to cancel the operation.



Caution: The tracks between these limits will be permanently erased.

Track Copy

Any track can be copied to another track.

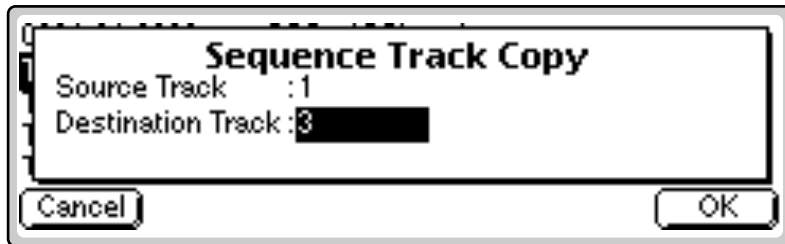

To Copy a Track:

1. From the main Sequencer screen, press the **Edit** function key (F3).
2. Press the **Utils** function key (F1). A second row of function keys appears.
3. Press the **TrkCopy** function key (F4). The TrackCopy menu shown above appears.
4. Select the **Source Track** to be copied.
5. Select the **Destination Track**.
6. Press **OK** to copy the track or **Cancel** to cancel the operation.

UNDO! (REDO!)

Have you ever wanted a time machine so that you could go back and undo a mistake? This function may be the next best thing. Whenever you perform any sequencer function, the original version of the sequence will be backed up. The sequence can be instantly restored to its previous state by pressing Undo.

REDO! reverses the Undo function and lets you compare the last and previous operations.

To Restore a Sequence to its Previous State (UNDO!)

1. Press the **Utils** key from the sequencer edit level. A second row of function keys appears.
2. Press the **UNDO!** function key (F6). The sequence will be restored to the state before the last operation was performed.

To Compare the Sequence with its Previous State (REDO!)

1. Press the **Utils** key from the sequencer edit level. A second row of function keys appears.
2. Press the **UNDO!** function key (F6). The sequence will be restored to the state before the last operation was performed.
3. Press the **REDO!** function key (F6) again. The processed sequence will be restored and the original sequence will be stored in the clipboard. You can continue switching back and forth until you decide which sample you want to keep.

Note: REDO! does not work with record functions.

Tools

The EOS Sequencer contains a host of special editing and filtering tools for modifying the sequence after it has been recorded.

Quantize. Adjusts the timing of notes so they fall exactly on the beat.

Transpose. Changes the key of a track section.

Velocity. Allows you to offset or scale velocity values within the selected section.

Channelize. Forces everything on a track to a single MIDI channel.

Extract. Separates individual channels from a multi-channel track.

To Access the Sequencer Tools Menu:

1. From the Sequencer Manage screen, press the **Edit** key (F5). The Sequencer Edit screen appears.
2. Press the **Tools** function key (F2). Another row of function keys appears.

Quantize

This function changes the timing of the notes in a sequence so that they fall exactly on the beat. This is useful when your playing was sloppy or to create drum tracks. Quantization can be applied in note values ranging from 1/4 notes to 1/64th note triplets.

Swing can be applied after recording to give a “bouncy” feel to your tracks. Swing quantizes the downbeats normally, but shifts the UPBEATS forward in time. A setting of 50% has no swing. Percentages from 60%, to 67% are normally used to get a nice “swing” feel.

Duration (when checked) will also quantize the note-off to the nearest note value. This changes the note duration which would make a quantized quarter note exactly one quarter note long.



Swing mode is disabled when the quantize amount is set to triplets.

Refer to the following diagrams to understand how quantize and swing mode work.

Quantize - 1/4 Note

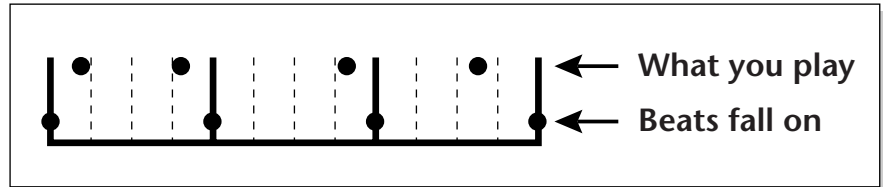

Notes are moved forward or backward in time so they fall exactly on the beat

 A Swing setting of 50% has no effect.

Quantize - 8th Notes, Swing 60%

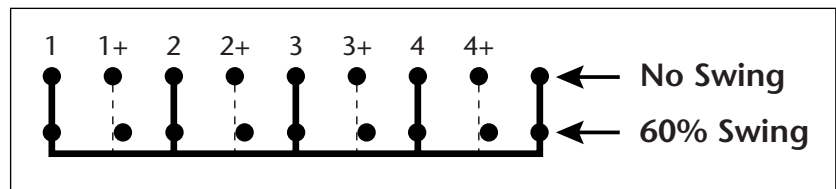

Upbeats are moved slightly forward in time.

Quantize - 8th Notes, Swing 67%

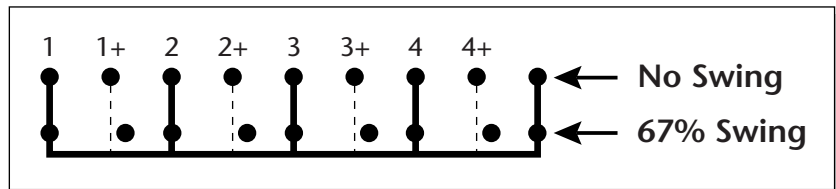

Quantize - 8th Notes, Swing 75%

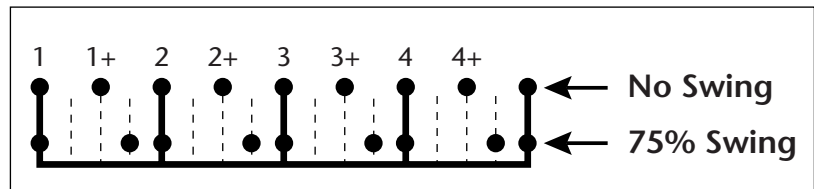

Upbeats are moved forward to the dotted eighth note.

To Quantize Tracks:

1. From the Sequencer Manage screen, press the **Edit** function key (F3).
2. Press the **Tools** function key (F2). A second row of function keys appears.
3. Press the **Quantize** function key (F1). The following screen appears.

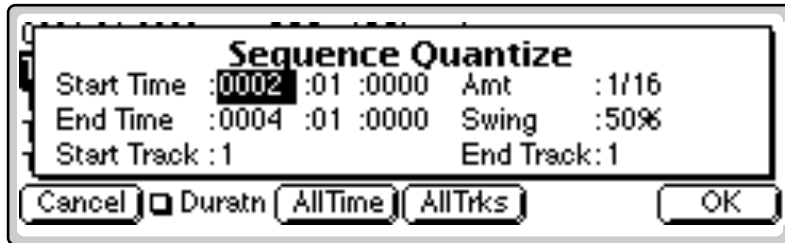

4. Select the **Start** and **End** time in bars/beats/ticks using the cursor keys to select the field and the Data Entry Control or INC/DEC keys to change the selection.
 - Press the **All Time** function key to select everything in the selected track(s).
5. Select the **range of tracks** to be quantized.
 - Press the **All Trks** function key to select all tracks.
6. Select the **Quantize Amount**. The selected section can be quantized to: 1/4 notes, 1/4 note triplets, 1/8 notes, 1/8 note triplets, 1/16 notes, 1/16 note triplets, 1/32 notes, 1/32 note triplets, 1/64 notes or 1/64 note triplets.
7. Select the **Swing Percentage** if desired. (50% = Off).
8. Turn **Duration** On or Off as desired.
9. Press **OK** to Quantize or **Cancel** to cancel the operation.

Transpose

This function allows you to transpose a section of a track up or down in semitone increments. The range of transposition is ± 128 semitones.

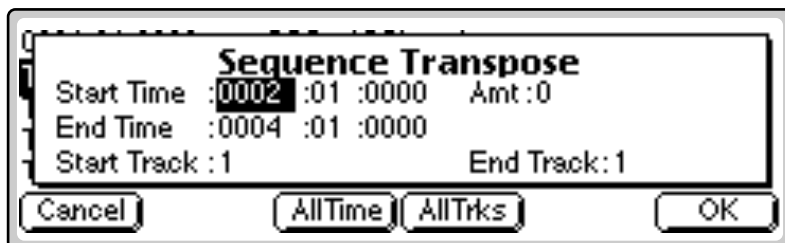

 **To Transpose a Section:**

1. From the Sequencer Manage screen, press the **Edit** function key (F3).
2. Press the **Tools** function key (F2). A second row of function keys appears.
3. Press the **Transpose** function key (F2). The screen shown above appears.
4. Select the **Start** and **End** time in bars/beats/ticks using the cursor keys to select the field and the Data Entry Control or INC/DEC keys to change the selection.
 - Press the All Time function key to select everything in the selected track.
5. Select the **range of Tracks** to be transposed by setting the Start and End tracks.
6. Select the **Transpose Amount**. The selected section can be transposed from -128 to +127 semitones.
7. Press **OK** to Transpose or **Cancel** to cancel the operation.

Sequence Velocity

This utility alters the velocity of recorded tracks and is a very powerful tool, allowing you to adjust the expression of many notes in one operation.

Velocity values can be scaled by a percentage amount or a fixed offset can be added to them. To illustrate the difference, suppose a note has a velocity of 50 and the Sequence Velocity Amount is set to 10. Using Offset would add 10 to 50 for a new velocity of 60. Using Percentage would increase the velocity by 10% of its original value. 10% of 50 = 5, resulting in a new velocity of 55.

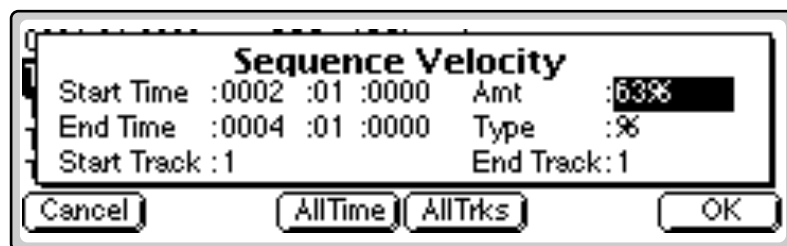

 **To Change the Velocity:**

1. From the main sequencer screen, press the **Edit** function key (F3).
2. Press the **Tools** function key (F2). A second row of function keys appears.
3. Press the **Velocity** function key (F3). The screen shown above appears.

4 - Sequencer Channelize

4. Select the **Start** and **End** time in bars/beats/ticks using the cursor keys to select the field and the Data Entry Control or INC/DEC keys to change the selection.
 - Press the **All Time** function key to select everything in the selected track.
5. Select the **range of Tracks** to be velocity scaled. Press the **All Trks** function key to select all tracks.
6. Select the **Type of scaling** (Percentage or Offset).
7. Select the **Velocity Amount**. Percentages range from 0% to 200%. You can offset the velocity from -127 to +127.
8. Press **OK** to change the Velocity or **Cancel** to cancel the operation.

Channelize

This tool lets you change the MIDI channel of a previously recorded track or section of a track. If the track contains multiple channels, they will all be converted to the new channel.

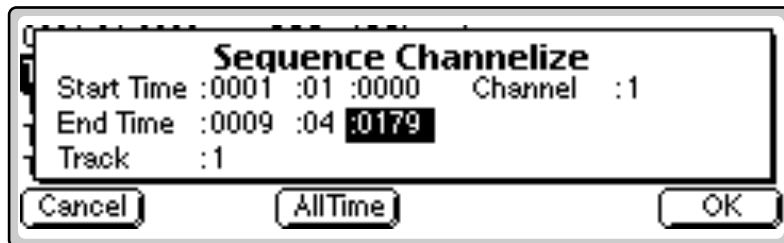

To Channelize a Track:

1. From the main sequencer screen, press the **Edit** function key (F3).
2. Press the **Tools** function key (F2). A second row of function keys appears.
3. Press the **Chnlize** function key (F4). The screen shown above appears.
4. Select the **Start** and **End** time in bars/beats/ticks. Use the cursor keys to select the field and the Data Entry Control or INC/DEC keys to change the selection. Press the **All Time** function key to select everything in the selected track.
5. Select the **Track** to be channelized.
6. Select the new **Channel** number.
7. Press **OK** to Channelize or **Cancel** to cancel the operation.

Channel Extract

Use this tool when you want to separate individual MIDI channels from a multichannel track. After Channel Extraction, each MIDI channel in the multichannel track is assigned to its own new track.

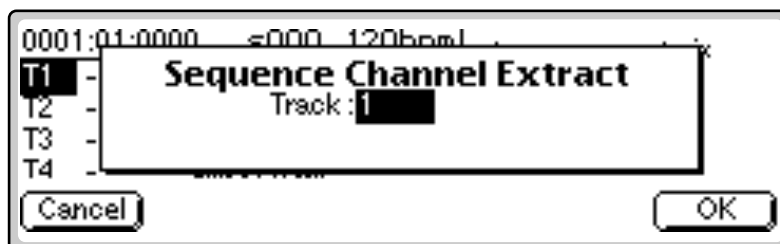

To Extract a Channel from a Track:

1. From the main sequencer screen, press the **Edit** function key (F3).
2. Press the **Tools** function key (F2). A second row of function keys appears.
3. Press the **Extract** function key (F5). The screen shown above appears.
4. Select the **Track** you want extracted.
5. Press **OK** to Extract the Channels or **Cancel** to cancel the operation. Each MIDI channel in the multichannel track is assigned to a new track number.

Setup

The Setup menu contains mostly pre-sequence setup options such as the metronome, tempo, input quantize, sequence looping, etc. It also contains the MMC transport controls which can be used to control digital recorders and tape machines.

The Setup submodule contains the following functions:

Metronome . Sets the metronome to play internal sounds or external MIDI instruments or both. It also allows you to select a MIDI channel, preset, note number, beat value and two velocities for the metronome tick.

Tempo. Sets the tempo, meter, and clock type. You can also turn MIDI Clock Out on or off.

Input Quantize. Lets you quantize and add swing to tracks as they are recorded. This is very useful when creating percussion tracks.

Record Options. Recording can be set to start when the sequence starts, after a specified number of lead-in beats or on the first note played.

Looping. The sequence can be made to continuously loop or to stop at the end of the song.

Transport. The MMC transport allows you to control an external 48 track recorder from the EOS panel. The internal sequencer can also be controlled from this screen.

To Access the Sequencer Setup Menu:

1. From the **Sequence Manage** screen, press the **Edit** key. The Sequence Edit screen appears.
2. Press the **Setup** function key (F3). Another row of function keys appears with the Sequencer Setup options.

 Use the Previous and Next Page keys to move back and forth through the Setup menus.

Metronome

The metronome provides an accurate beat for recording and is especially important when Quantizing since notes are quantized according to the metronome's clock.

This screen lets you choose the MIDI channel, preset, note number and accent velocity for the metronome sound.

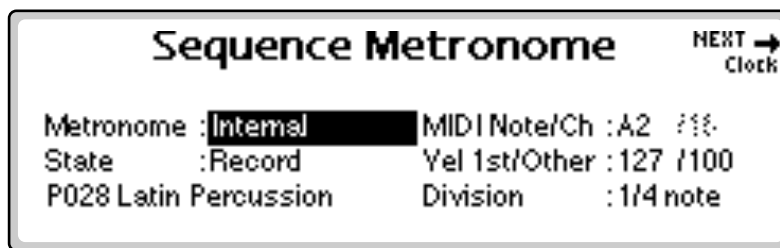

Metronome . When in Internal mode, an onboard preset is used to produce the metronome sound. In External mode, the metronome generates a MIDI note to play the metronome note on an external synthesizer.

State . The metronome state determines whether the metronome will play when recording, in playback, or in record and play modes (both).

Preset. Selects the internal preset that the metronome uses when set to internal mode. A percussion instrument, such as a woodblock or rimshot, would be a good choice for the metronome sound, although any sound with a sharp attack can be used.

MIDI Note/Channel. Selects the note that will be used for the metronome sound. Select a MIDI channel if you are using an external MIDI instrument for the metronome sound.

Vel 1st/Other. This parameter allows you to set the velocity value for the first beat and subsequent beats in the measure. The first note is normally set to a higher velocity in order to identify the start of each measure. Note: The preset must have velocity programmed for this feature to work correctly.

Division. Division sets the meter for the metronome beats. Choose from Quarter notes, Eighth notes, or Sixteenth notes.

4 - Sequencer Sequence Clock



Use the Previous and Next Page keys to move back and forth through the Setup menus.



Note: The Preset screen is not accessible when External Metronome is selected.



If the metronome preset has effects on it (and you don't want effects):

1. Copy the preset.
2. Assign it to a Submix out with 0% effects.
3. Save the Bank.
4. Assign the Metronome to the new Preset.

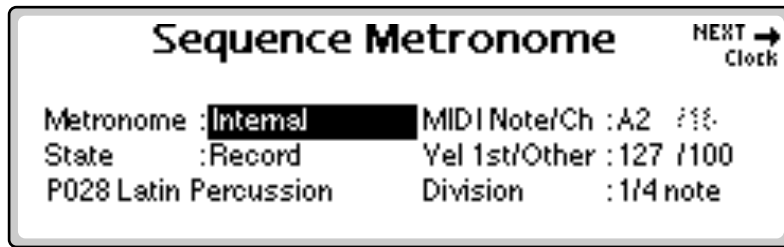



To Set Up the Metronome:

1. From the main sequencer screen, press the **Edit** function key.
2. Press the **Setup** function key (F3). A second row of function keys appears.
3. Press the **Metro...** function key (F1). The screen shown above appears.
4. Set the **Metronome** to Internal, External or Both.
5. Set the **State**. This sets the metronome to sound during record, playback or both.
6. Select the **Preset** if you are using the metronome in Internal mode.
7. Select the **MIDI Note** and **MIDI Channel**. As you change the note it will be transmitted so that you can hear which metronome sound you are selecting.
8. Select the **Note Velocity** for the first note in the measure and for subsequent notes. Usually the first note will be set to a higher velocity to accent the first note of the measure.
9. Set the **Note Value** in quarter notes, eighth notes or sixteenth note for the metronome.
10. Press **Exit** to lock in the Metronome settings and return to the Sequence Edit screen.

Sequence Clock

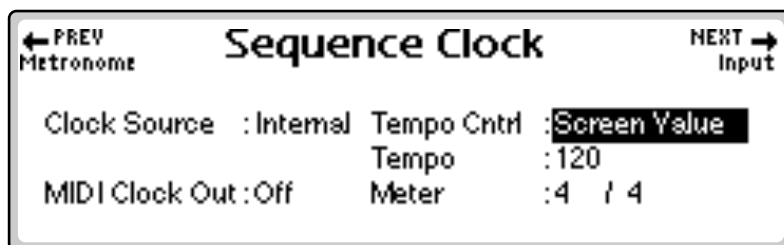
This screen sets the tempo and meter of a sequence. The sequencer tempo can be controlled by an internal or external clock. This screen also turns MIDI Clock Out on or off.



 *The Tempo and Meter screen are not accessible when Tempo Track is selected.*

 *The Arpeggiator and Sequencer use the SAME CLOCK.*

*Change the Arpeggiator clock to adjust the tempo of Flash sequences ...
...or Copy the Flash sequence to RAM, then adjust the tempo.*

Clock Source. Determines if the sequencer clock is controlled by the internal or and external (MIDI) clock.

Tempo Control. Allows the tempo of a sequence to be controlled in one of three ways:

- a. By the Tempo Track stored in the sequence. An initial tempo value is stored when you create a new sequence. Sequences imported from an external sequencer may have tempo changes within the song.
- b. By the adjustable Screen Value tempo value shown in this display.
- c. By an External Clock (MIDI).

Tempo. Sets the tempo (speed) of the sequence and is adjustable from 20 beats per minute (bpm) to 240 bpm.

Meter. Sets the time signature of the song. The Meter setting is used by the metronome function to determine measures and beats.

MIDI Clock Out. Turns MIDI Clock Out on or off. Turn this feature on if you want to control an external MIDI device with the sequencer clock.

To Set the Clock:

1. From the main sequencer screen, press the **Edit** function key (F3).
2. Press the **Setup** function key (F3). A row of function keys appears.
3. Press the **Clock** function key (F2).
4. Select the **Clock Source** as internal or external clock.
5. Set the **Tempo Control** to Tempo Track, Screen Value or External Clock.
6. Set the desired **Tempo** (if Screen Value is selected)
7. Set the desired **Meter** (if Screen Value is selected). Any time signature can be programmed.
8. Turn **MIDI Clock Out** On or Off.
9. Press **Exit** to lock in the Clock settings and return to the Sequence Edit screen.

Sequence Input

This screen allows you to quantize and add swing to a sequence as it is recorded. This is particularly useful when recording drum parts. When you know you want a track to be quantized this is the fastest and easiest way to do it.

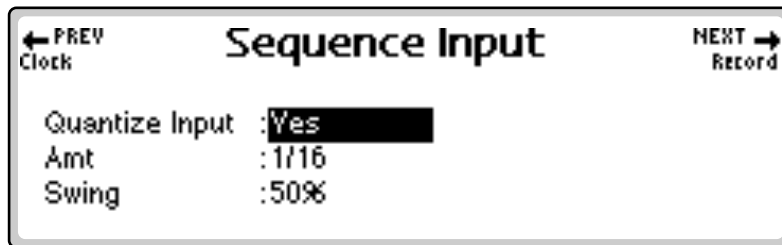

 A small "Q" symbol appears in the Edit screen to remind you that Input Quantize is turned On.

It is important to set up the Metronome and Meter when using quantization. The sequencer quantizes to the Metronome beat and the Metronome beat is controlled by the Meter setting.

Quantize Input. Turns Input Quantization On (yes) or Off (no).

Amount. Sets the note value for quantization if Quantize is turned on. Data input to the sequencer can be quantized to: 1/4, 1/4 triplet, 1/8, 1/8 triplet, 1/16, 1/16 triplet, 1/32, 1/32 triplet, 1/64 or 1/64 triplet.

Swing. Sets the swing value if Quantize is turned on. A value of 50% equals no swing. Normal swing values range from 50% - 80%.

 See Quantize in the Tools section for diagrams illustrating how Quantize and Swing work.

To Set the Input Functions:

1. From the main sequencer screen, press the **Edit** function key (F3).
2. Press the **Setup** function key (F3). A second row of function keys appears.
3. Press the **Input** function key (F3). The screen shown above appears.
4. Turn input **Quantize** On or Off (Yes or No).
5. Set the **Quantization Amount**.
6. Select the **Swing** percentage if desired (50% = No Swing).
7. Press **Exit** to lock in the Sequence Input settings and return to the Sequence Edit screen.

Sequence Record

These two functions determine when sequence recording begins.



Start Record -

Button Press: Recording begins as soon as you press the Record and Play buttons and after the selected Count In beats (see below) have elapsed.

First Note: Recording begins as soon as you press any note on the keyboard. The Count In beat setting is ignored.

 The Count In field is not available unless Button Press is selected.

Count In

Sets the number to metronome beats which will occur before actual recording will commence. The number of count In beats can be set from 1 to 127 or turned Off.

To Set the Sequence Record Functions:

1. From the main sequencer screen, press the **Edit** function key (F3).
2. Press the **Setup** function key (F3). A second row of function keys appears.
3. Press the **Record** function key (F4). The screen shown above appears.
4. Set **Start Record** for Button Press or First Note.
5. Set the number of **Count In** beats.
6. Press **Exit** to lock in the Sequence Record options and return to the Sequence Edit screen.



Loop settings are NOT saved with the sequence.

Sequence Loop

Any region of a sequence can be programmed to loop. The sequence plays through the Start Time until the selected End Time is reached. It will then immediately jump back to the Start Time and the sequence will continue to play between the selected Start and End times.

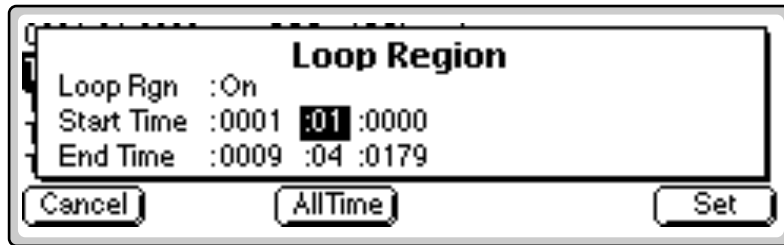

Loop Region. Turns looping on or off.

Start/End Time. Selects the Start and End times for the looping region in bars:beats:ticks.

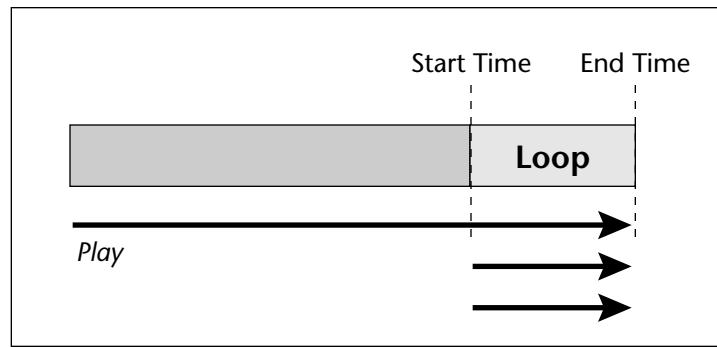

To Set the Sequence Loop:

1. From the Sequencer Manage screen, press the **Edit** function key (F3).
2. Press the **Setup** function key (F3). A second set of function keys appears.
3. Press the **Loop** function key (F5). The screen shown above appears.
4. Turn **Loop Region** On or Off.
5. Select the **Start** and **End** time in bars/beats/ticks using the cursor keys to select the field and the Data Entry Control or INC/DEC keys to change the selection. The start time will default to the current sequence position.
 - Press the **All Time** function key to select everything in the selected track(s).
6. Press **Set** to set the Loop Region or **Cancel** to cancel the operation.

Transport

This screen contains several functions and allows you to change the function of the sequencer transport buttons.

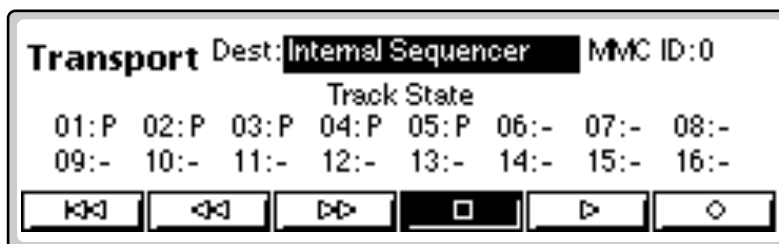

The transport buttons can be set to control the internal sequencer, an external sequencer, or a MIDI Machine control device such as a digital tape machine or hard disk recorder. The transport (record, play, etc.) and track state (record, play, solo, mute) of up to 16 different machines (with up to 48 tracks each) can be controlled from this screen.

Destination. Selects what is being controlled from the MMC Transport. Can be set to Internal Sequencer or MIDI Machine Control (MMC).

MMC ID. Selects which external device is currently being controlled (0-15). Match this number to the ID of the external device you wish to control.

Track Status Options:

- P:** Plays the track.
- M:** Mutes (silences) the track.
- S:** Solos the track. Solo plays only those tracks which are in Solo mode.
- R:** Places the track into Record mode.
- O:** Overdub - Allows you to record additional data on a track.
- :** Indicates the track is empty.

To Use the MMC Transport:

1. From the Sequence Manage screen, press the **Edit** function key (F3).
2. Press the **Setup** function key (F3). A second row of function keys appears.
3. Press the **Trnsprt** function key (F6). Another row of function keys appears allowing you to select a group of 16 tracks (1-16, 17-32, 33-48).
4. Select a Group of Tracks.
5. Select **Internal** or **MMC** as the Transport Destination.
6. Set the **MMC ID** if MMC is selected as the Transport Destination.

7. Select the **Track State** using the cursor keys to select the field and the Data Entry Control or INC/DEC keys to change the selection.
8. Press **Exit** to lock in the settings and exit the submodule.

Received MMC Commands

The following MMC commands are always received by EOS. This allows the EOS sequencer to be controlled via a remote MIDI device that transmits MMC commands.

Record Exit	Same as Stop
Stop	
Fast Forward	
Rewind	
Locate	Same as RTZ
Record Strobe	Begins recording at the beginning of the sequence.
Play	

Locate

Locate points allow you to instantly jump to any time location in a song. This feature can be very handy to mark sections of a song, such as the chorus and bridge, or when rehearsing. Up to 8 locate points can be entered in addition to the start and end points. The 8 locate points are used for all sequences and are not saved with the bank. They are meant to be used as temporary markers while working on your sequence.

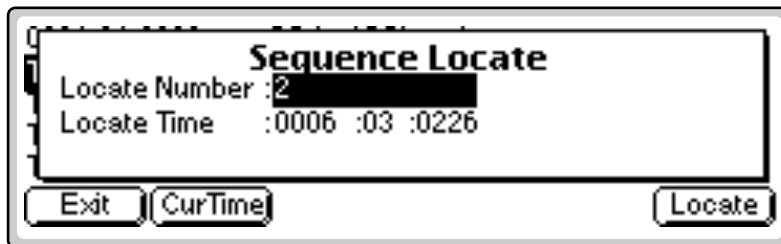

To Access the Sequence Locate Window:

1. From the Sequencer Manage screen, press the **Edit** key (F5). The Sequencer Edit screen appears.
2. Press the **Locate** function key (F4). The popup Locate window shown above appears.

To Store and Jump to a Locate Point:

1. From the Sequence Locate window, **select** one of the eight **Locate Points**.
2. Move the cursor down to the second line and enter the **Locate Time** using the numeric keys, INC/DEC keys or the Data Entry Control.
 - Press the **CurTime** function key to select the Current Time.
3. Press **Locate** to jump to the entered Locate Point or **Exit** to go back to the Sequencer Edit screen.

4 - Sequencer

Sample Manage

5

5 - Sample Manage

Overview



This “recording studio” module records sounds from the outside world into the bank. Features include adjustable preamp gain, variable threshold setting, and adjustable sample rate and length. Samples can also be named, copied, erased and automatically placed on the keyboard.

The Sample Manage menu contains six main sub menus:

Utilities. Contains the Erase, Copy, MIDI Sample Dump and Defragment functions.

Name. Allows you to name your samples.

New. The recording studio where sounds are sampled. This module also contains automatic DSP and setup functions such as auto-truncate, auto-normalize, auto-sample placement, auto looping.

Place. Allows you to assign the sample to any range of notes on the keyboard.

Export. Allows you to save an individual sample as a bank.

Info. Displays information on the selected sample.

Sample Utilities



The Sample Utilities menu contains several functions.

- Erase Sample
- Copy Sample
- Sample Dump
- Defragment Memory

Erase Sample

The Erase Sample operation erases individual samples from the bank.

To Erase a Sample:

1. Press the **Sample Manage** key. The LED illuminates and the main screen appears.
2. Select the sample to be erased using the Data Entry Control, INC/DEC keys, or the numeric keypad.
3. Press the **Utils** function key (F1). A second row of function keys appears.
4. Press the **Erase...** function key (F1). A pop-up dialog box appears asking if you want to erase the selected sample.
5. Press **OK** to erase the sample. Another dialog box appears asking if you want to de-fragment the memory after erasing the sample.
6. Press **Yes** to defragment memory and erase the sample. Press **No** to erase the sample without defragmenting memory, or press **Cancel** to cancel the entire operation.



For more information about Defragmenting Memory, see "Defragment Memory" on page 177

Copy Sample

Copying a sample duplicates the sample data so you can edit the copy and preserve the original sample. You can copy a sample to an empty sample number or overwrite an existing sample number.

To Copy a Sample:

1. Press the **Sample Manage** key. The LED illuminates and the main screen appears.
2. Select the sample you want to copy using the Data Entry Control or the INC/DEC keys. The Sample Clipboard can also be selected.
3. Press the **Utils** function key (F1). A second row of function keys appears.
4. Press the **Copy...** function key (F2). A pop-up dialog box appears asking you to select the destination sample location.
5. **Select the destination** sample location using the Data Entry Control, INC/DEC keys or the numeric keypad.

If you choose a destination that already contains a sample, the system asks you if you want to overwrite the existing sample before continuing.

6. Press **OK** to copy the sample or **Cancel** to cancel the operation.

Sample Dump

MIDI Sample Dump lets you transfer sample data to and from the Emulator using the MIDI Sample Dump Standard. This is a way of transferring samples to and from other samplers. Although none of the preset parameters are transferred, sample loop data is retained. If imported samples have loop problems such as "ticks or pops", the Sample Integrity function (Sample Edit, Utilities) may be able to automatically repair them. Otherwise adjust the loop points.

Sample data can be transmitted with a word size of either 14 or 16 bits (some instruments require the use of the 14 bit word size). Use 14-bit mode for instruments that use 14 bits or less to transmit data 30% faster.

Before initiating MIDI Sample Dump, make sure that the MIDI cables are properly connected. A single MIDI cable (open-loop) is sufficient but the data transfers much faster if two MIDI cables are used (closed-loop). The closed-loop allows the two units to handshake and prevents idle time between each data packet. Connect the cables between the MIDI In and MIDI Out of both units.

In the MIDI Sample Dump Standard and in EOS, samples are assigned numbers and these numbers are maintained throughout the transfer. For example, sample #36 transferred from another device to the Emulator overwrites the existing sample #36 on the Emulator.



To Send or Receive a Sample:

1. Connect the **MIDI IN** to the **MIDI OUT** connectors on both units, using MIDI cables.
2. Press the **Sample Manage** key. The LED illuminates and the main screen appears.
3. **Select the sample** to be transmitted or received using the Data Entry Control, INC/DEC keys, or the numeric keypad.
4. Press the **Utils** function key (F1). A second row of function keys appears.
5. Press the **Dump...** function key (F3). A pop-up dialog box appears with several choices.
 - **Direction:** Select Transmit or Receive.
 - **Word Size:** Select 14 or 16 bits.
 - **Side:** If the sample is stereo, you have the option to select the right or left side.
6. **Select the sample** using the Data Entry Control, INC/DEC keys or the numeric keypad.
7. Press **OK** to dump the sample or **Cancel** to cancel the operation.

When receiving a sample, the currently selected sample will be overwritten by the incoming sample.

Defragment Memory

When samples are erased or truncated, empty spaces are left in sample memory until the bank is saved to disk

Because the memory space is not filled efficiently, we call this condition “Fragmented Memory”. Fragmented memory may limit new sample size, even though you have plenty of memory left. This function allows you manually de-fragment the memory. Memory is automatically defragmented when a bank is saved to disk.

To Defragment Sample Memory:

1. Press the **Sample Manage** key. The LED illuminates and the main screen appears.
2. Press the **Utils** function key (F1). A second row of function keys appears.
3. Press the **Defrag...** function key (F4). A pop-up dialog box appears asking you if you want to de-fragment sample memory.



4. Press **OK** to defragment memory or **Cancel** to cancel the operation.

Sound Memory

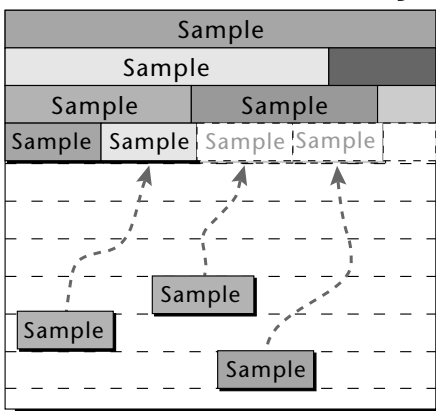

Defragmenting Sample Memory collects stray samples and packs them together in one chunk.

Name Sample

This function allows you to name or rename any sample in the bank.

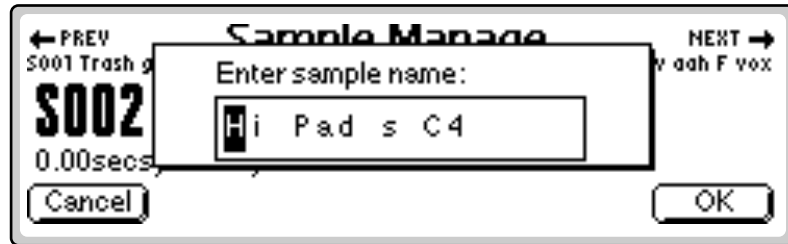

To Name a Sample:

1. Press the **Sample Manage** key. The LED illuminates and the main screen appears.
2. **Select the sample** to be named using the Data Entry Control, INC/DEC keys, or the numeric keypad.
3. Press the **Name** function key (F2). A pop up dialog box appears asking you to enter the new sample name.
4. **Name the sample.** Select letters using the numeric keypad, Data Entry Control, INC/DEC keys and cursor keys, or using an ASCII keyboard.
5. Press **OK** to confirm the new name or **Cancel** to cancel the operation.

New Sample

This submodule prepares the Emulator for making a sample. The Emulator triggers sampling using one of three different trigger modes: Keyboard, Arm, and Force. The New Sample submenu contains the sampling trigger controls and automatic DSP and auto-sample placement controls. The following functions are integrated into this important submodule.

- **Threshold**
- **Left and Right Input Meters**
- **Sample Through Monitor Select**
- **ADC Gain**
- **Sampling Source and Source Sample Rate**
- **Sample Length**
- **Dither**
- **Arm Sample**
- **Force Sample**
- **Keyboard Sample Trigger**
- **Automatic DSP**
- **Automatic Sample Placement**

The next few pages describe these parameters and functions in detail.

Threshold

In the Arm Sampling mode, sampling begins when the input signal exceeds the threshold setting. The Threshold field defines this level. Set the sampling threshold high enough so that it is not triggered by background noise, but low enough that all of the signal is captured. Sampling is actually initiated just before the threshold is exceeded in order to preserve the attack transient of the sound. This is called pre-sampling. Pre-sampling times are preset depending on the sample rate; 12 mS at 44.1 kHz and above, 17 mS at 24 kHz and below (see Sampling Source & Rate for more information).

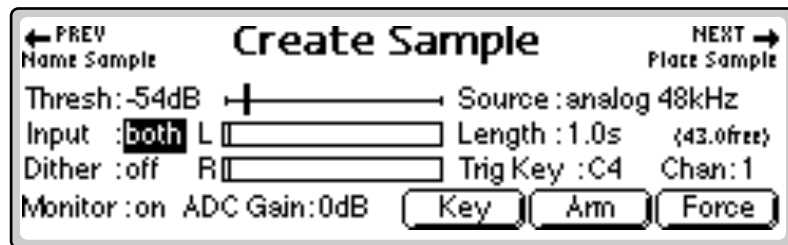

☞ To Set the Sample Threshold:

1. Press the **Sample Manage** key. The LED illuminates and the main screen appears.
2. Press the **New** function key (F3). The “Create Sample” display appears.
3. If it is not already there, move the cursor to “**Threshold**” using the cursor keys.
4. While observing the input signal on the VU meters, **adjust the Sampling Threshold** using the Data Entry Control, or INC/DEC keys.
5. Press the **Exit** key to return to the Sample Manage screen.

Input Channels

Select Left, Right or Both: The Input field determines which channels are On or Off and controls both the analog and digital inputs (AES and ADAT). The input levels are displayed in the VU Meter (the VU meter is used to help set the ADC Gain). Use the INC/DEC keys or Data Entry Control to select Left, Right or Both channels. If sampling in mono, use the LEFT channel ONLY since the Threshold trigger only monitors the left channel.

Sampling Source & Rate

The Source field defines the sampling source and the rate at which the information is sampled. It is important to use the lowest rate possible (to conserve memory) that is at least twice as high as the highest frequency component in the sound being sampled. If the sampling rate is too low, you will lose some of the high frequency information.

5 - Sample Manage New Sample



If an ADAT Optical card is installed, you will have four additional digital sampling source options:

- ADAT in 1 and 2
- ADAT in 3 and 4
- ADAT in 5 and 6
- ADAT in 7 and 8



20 bit resampling is only available on the Ultra series Emulators.

Analog Sampling: Choose between 22.05 kHz, 24 kHz, 44.1 kHz or 48 kHz when using the analog inputs. The sample rate should be at least twice as high as the highest frequency component in the sound being sampled.

Ultra Series - Only two of the four sample rates will be shown at one time (22.05 kHz & 44.1 kHz) or (24 kHz & 48 kHz). To select a sample rate which is not currently displayed, press Master, Setup, In/Out, then change the Default Clock rate.

Digital Sampling. Choose between 32 kHz, 44.1 kHz or 48 kHz when using the digital input. The display setting should match the sample rate of the incoming digital data, otherwise the Arm and Force Sample function keys cannot be selected. If a digital source is not connected, the AES clock indicator displays “no AES” and sampling is disabled.

A sample overload message is displayed if digital audio containing “Full Code” data (all 1's) is detected. This indicates that the input data has been clipped at some point. Full code data may distort in the Emulator because changing the pitch can cause a slight gain increase. If possible, reduce the level of the incoming digital data if you see an overload message.

Resampling: This function allows you to resample the main outputs as you are playing. Resampling lets you build up extremely dense sounds or record a sequence of notes to be played back with a single key. There are three resampling modes, 16 bit, 18 bit and 20 bit. Use 16 bit mode for monophonic or duophonic passages. The 18 and 20 bit modes give you more headroom when playing many notes at once. If clipping occurs, use a higher bit mode.

To Set the Sample Source:

1. Press the **Sample Manage** key. The LED illuminates and the main screen appears.
2. Press the **New** function key (F3). The “Create Sample” screen appears.
3. Move the cursor to “**Source**” using the cursor keys.
4. **Select the desired sampling source** using the Data Entry Control or INC/DEC keys.
5. Press the **Exit** key to return to the Sample Manage screen.

Dither

Dither is a technique used in digital systems to improve audio performance by adding noise to the least significant data bits. Dither should be used whenever a digital number is converted to a smaller number (for instance when converting 20 bits to 16 bits).

EOS samples at 16 bit linear, so dither should be turned On when digitally sampling from a source that has more than 16 bits, for example when sampling a 24 bit AES signal or when sampling from a 20 bit ADAT machine. Dither can be either On or Off when analog sampling (the audio performance is the same).

ADC Gain

ADC stands for Analog-to-Digital Converter. The ADC Gain field defines the dynamic range for the sample. Setting too high an ADC gain may cause clipping. Set the analog sample level with the Data Entry Control or INC/DEC keys so that the left and right side meters indicate optimum sampling level. Play the sound to be sampled and observe the bar graph display. The signal level should be set so that the peak bar comes close to the extreme right side without actually reaching it. The gain is adjustable from -18 dB to +30 dB in 2 dB steps. This control has no effect on the digital input.

To Set the ADC Gain:

1. Press the **Sample Manage** key. The LED illuminates and the main screen appears.
2. Press the **New** function key (F3). The following display appears.

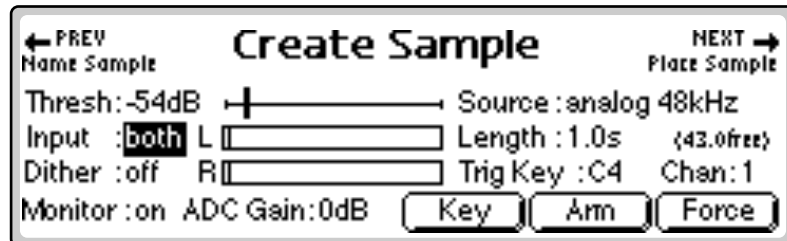

3. Move the cursor to “ADC Gain” using the cursor keys.
4. Plug in a microphone or other sample source to view the left and right VU meters.
5. While monitoring the sound to be sampled on the VU meters, adjust the **ADC Gain** using the Data Entry Control or INC/DEC keys. Set the level so that the bars never quite reach the top of the meter range.
6. Press the **Exit** key to return to the Sample Manage screen or **Arm** or **Force** to begin sampling.

Sample Length

This parameter defines the amount of sampling (recording) time prior to sampling. The maximum available length depends on the amount of memory available and the sampling rate.

To Set the Sample Length:

1. Press the **Sample Manage** key. The LED illuminates and the main screen appears.
2. Press the **New** function key (F3). The "Create Sample" display appears.
3. Move the cursor to "**Length**" using the cursor keys.
4. **Set the desired sample length** using the Data Entry Control, or INC/DEC keys. The display shows the amount of available sampling time on the line immediately below the sample length.
5. Press the **Exit** key to return to the Sample Manage screen or **Arm** or **Force** to begin sampling.

Arm Sample Trigger

The Arm function sets the sampling mode to Arm. This means that the sampling is ready to begin as soon as the sound you are sampling exceeds the sampling threshold level (as defined in the Threshold field). Once selected, you are ready to begin sampling. EOS starts sampling when the threshold level is met.

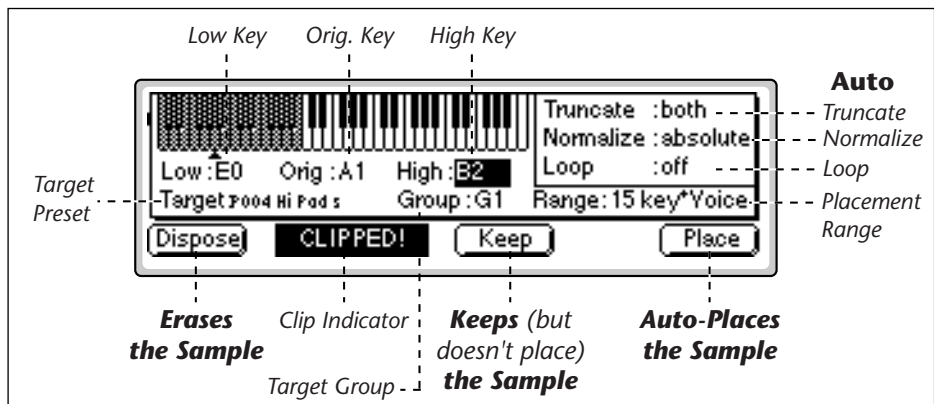

To Arm Sampling:

1. Press the **Sample Manage** key. The LED illuminates and the main screen appears.
2. Press the **New** function key (F3). The Create Sample display appears.
3. Press the **Arm** function key (F5) to arm sampling.

Sampling starts when the input signal exceeds the programmed threshold.

To Stop Sampling:

1. Press **Stop** (F1), **Enter** or **Exit** to stop sampling before the programmed sample length is reached.

Force Sample Trigger

The Force sampling mode causes sampling to begin immediately (without waiting to exceed the threshold or pressing a key on the keyboard).

To Force Sampling:

1. Press the **Sample Manage** key. The LED illuminates and the main screen appears.
2. Press the **New** function key (F3). The Create Sample display appears.
3. Press the **Force** function key (F6) to force sampling. Sampling will commence immediately.

To Stop Sampling:

1. Press **Stop** (F1), **Enter** or **Exit** to stop sampling before the programmed sample length is reached.

Keyboard Sample Trigger

The Keyboard Trigger mode initiates sampling when you play a specified MIDI note. Sampling continues as long as the key is pressed and stops when the key is released (or the selected sample length is reached). Keyboard triggered sampling has several uses:

- Automatic “punch-in/punch-out” using a MIDI sequencer to initiate sampling via note-on/note-off events. This makes it easy to integrate “live” vocal or guitar parts into your MIDI sequences.
- Turns the Emulator into a digital multitrack recorder. Assign the lowest note to be the trigger key. Select resample. Sample length to maximum. Now press and hold the key while playing the keyboard with your left hand. Assign the sample to the trigger key, select another preset and record track two...and repeat the process. You have 64 or 128 tracks, depending on how many voices in your Emulator.

To Trigger Sampling from a Key Depression:

1. Press the **Sample Manage** key. The LED illuminates and the main screen appears.
2. Press the **New** function key (F3). The Create Sample display appears.
3. Move the cursor to **Trig Key** and select the key using the Data Entry Control. INC/DEC keys or the keyboard.
4. Move the cursor to **Chan** and select the MIDI Channel for the trigger key using the Data Entry Control, or INC/DEC keys.
5. Press the **Key** function key (F4) to enable Key Sample Trigger. A pop-up dialog box appears informing you that sampling is armed.

To Stop Sampling:

1. Press **Stop** (F1), **Enter** or **Exit** to stop sampling before the programmed sample length is reached.

Monitor On/Off

With Monitor turned On, you can monitor the input source through the main outputs before, during and after sampling takes place. As a rule, you want to leave the Monitor on so that you can monitor your sample quality. On occasion there may be instances, such as a feedback loop in the mixing board, where you would want to turn sample monitor Off.

Automatic Parameters

After sampling, the automatic parameters screen appears. You will perform certain sample processing functions on every sample you take. EOS can automatically perform these processes for you when you decide to keep it. After taking the sample you have three choices for what to do next: Dispose, Keep, and Place. This section describes these options and the automatic DSP operations performed on the sample. If clipping occurred during sampling, the display informs you at this time.

Dispose: Discards the sample and returns you to the New Sample menu.

Keep: Keeps the sample and performs the auto-DSP functions, but does not auto-place the sample. Returns you to the New Sample menu.

Place: Keeps the sample, performs the auto-DSP functions and auto-place functions, then returns you to the New Sample menu. When Place is selected, the sample is automatically placed in the target preset, group and range defined. See Auto-Placement Parameters.

Automatic Digital Signal Processing Operations

The automatic DSP parameters are as follows:

Truncate: (*Off, Start, End, Both*). Automatically truncates the beginning, the end, or both the beginning and end of the sample. The point or points at which the sample is truncated is defined by the Zero Crossing Threshold parameter in the Master, Misc module.

Auto Normalize: (*Off, Absolute, Relative*) . Automatically increases the amplitude of a sample until the largest peak reaches 100% of full scale. Relative mode increases the amplitude of stereo samples until the largest peak of one side reaches 100%. Both sides maintain their proper amplitude relationship. Absolute mode increases the left and right samples to full level independently. Absolute and Relative have no effect when sampling in mono.

Auto Loop: (*Off, Whole, 1/2, 1/2 + xfd, 1/3, 1/3 + xfd, 1/4, 1/4 + xfd, 1/8, 1/8 + xfd*). This function automatically loops and autocorrelates the sample, then crossfade loops it if selected. Matching the loop length to the type of sample is important for getting the best results from auto loop. Ensemble sounds are notoriously hard to loop and are best looped manually.

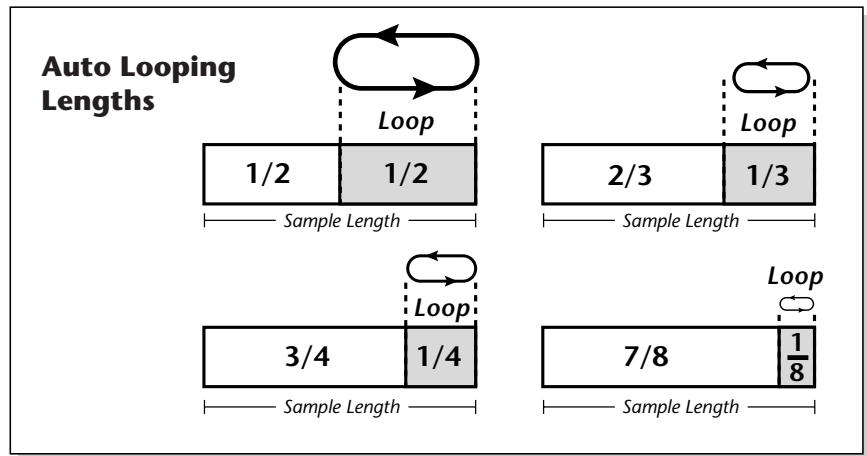

Select the auto looping length to match the type of sound. Loop on sections of the sound where the tone and amplitude are fairly static.

Crossfade looping smoothly crossfades between the waves on either side of the loop so that the data at the loop splice points are identical. Since Crossfade looping permanently modifies the sample data, you may want to turn this feature off when it is important to maintain the integrity of the data. Auto-crossfade is a linear crossfade and sets the crossfade size to 1/2 the loop length. Experiment with auto-loop using 1/4 to 1/3 sized loops to start. In most cases, you'll find that auto-loop produces amazingly good results.

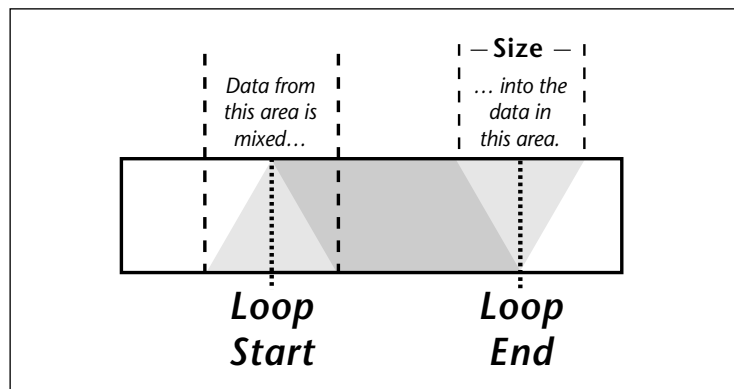

Crossfade Looping uses data from around the loop start point and cross fades this data into the area around the loop end point.



Be sure to change the target preset when resampling or you may place the sample into the same preset you are sampling from.



Multisample voices contain multiple samples. The Expand function in the Preset Edit menu creates individual voices for each sample in a Multisample.

Auto-Placement Parameters

The auto-placement parameters define which preset, group, and range of keys to place the sample on the keyboard when the sample is placed automatically.

Target Preset: Selects the preset to which the sample will be auto-placed.

Target Group: Selects a group number for the sample.

Range: Samples will be placed on the keyboard according to the selected placement range, beginning with the original key. The original key can be changed at any time to change the placement of samples.

The choices for range are:

- **Auto* Multisample:** This function places consecutive samples into a multisample voice at the original key you select from your MIDI keyboard. As you take additional samples, the low and high keys are adjusted in order to fit the new samples onto the keyboard. You don't ever have to set the low and high keys! Simply define the original pitch and you're finished. Samples are automatically named using the name of the preset appended with the original key name (i.e. Strings C1).

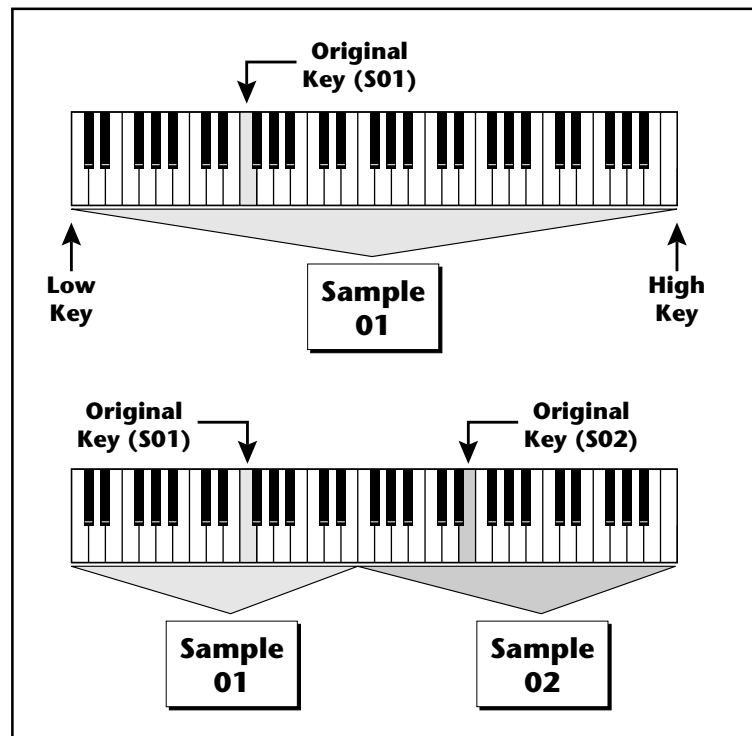

Auto* Multisample: The first sample is placed over the entire keyboard. When a new sample is taken, the low and high keys are automatically adjusted to accommodate the new sample.

- **White Key* Voice:** A new sample will be placed on the lowest available white key beginning at the original key you select (C1 is the default starting key). Each new sample will create a new voice.
- **1 Key* Voice:** A new sample will be placed on the lowest available white or black key beginning at the original key you select (C1 is the default starting key). Each new sample will create a new voice.
- **2-24 Key* Voice:** New samples will be placed over a keyboard range consisting of the number of keys selected. You can select the starting key by manually setting the original key (C1 is the default starting key). Each new sample will create a new voice.

To Create an Auto-Multisample:

This function works especially well for sampling other synthesizers.

1. Press the **Sample Manage** key. The LED illuminates and the main screen appears.
2. Press the **New** function key (F3). The Create Sample display appears.
3. **Set up the sampling parameters** such as sample length, sample source.
4. **Take the sample.** The auto-placement screen appears.
5. Press the **Original Key** on your MIDI keyboard.
6. Set **Truncate** to Both, **Normalize** to Relative, **Loop** to 1/4 + xfade.
7. Set **Range** to auto* Multisample.
8. Set the **Target Preset** to an empty location.
9. Press **Place**. You will be asked to name the preset (if it was empty).
10. **Name the preset** and press **OK**. EOS performs the DSP functions, then auto-places the sample.
11. If you wish to take additional samples do so now. Simply **define the original key** using your MIDI keyboard then press **Place** after taking each sample.

Place Sample

After sampling, a sample is automatically assigned to its own voice. This function allows you to place the voice (and the sample) if you chose to keep it and now want to place it, or if you placed the sample and later want to place it somewhere else.

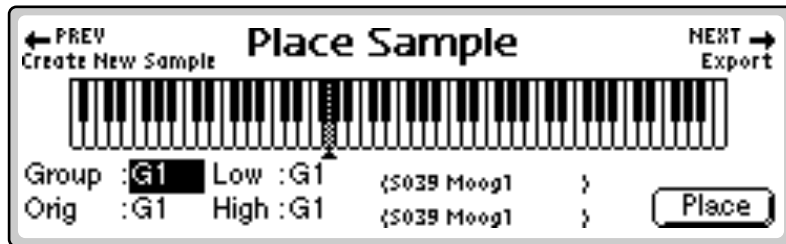

To Place a Sample:

1. Press the **Sample Manage** key. The LED illuminates and the main screen appears.
2. **Select the sample** to be placed using the Data Entry Control, INC/DEC keys, or the numeric keypad.
3. Press the **Place** function key (F4). The screen shown above appears.
4. The sample can also be assigned a group number at this stage as a convenience. Use the Data Entry Control or INC/DEC keys to change the group number if desired.
5. Set the **Original Key** and the **High** and **Low** keys for the voice. Use the Cursor keys or function keys to select the parameter and the INC/DEC keys, your MIDI keyboard or the Data Entry Control to change the key range.
6. Press **Place** to confirm placement or **Exit** to cancel the operation.

 **Hot Tip!** To save all the samples in a bank in EIIIx format, press and hold the decimal point key while you press the Save key. The display will offer you the option to save in these alternate formats. Select the desired format using the function keys.

- Note that only samples are transferred, not the presets.

Export Sample

This function allows you to export a single sample as a self-contained bank in any of four different sample formats. The formats are:

- **EIIIx** Compatible with EIIIx samplers
- **Emulator IV** Native format of all EOS based Emulators
- **WAVE** Microsoft Windows .WAV file format (*floppy export only*)
- **AIFF** Apple sound file format (*floppy export only*)

Suppose you were experimenting and modified a sample using the sample edit module. The sample data is permanently changed. You want to keep the modified sample, but if you save the bank, the original sample will be lost. Using this function, you can export the modified sample to a new bank and have both!



To Export a Sample:

1. Press the **Sample Manage** key. The LED illuminates and the main screen appears.
2. **Select the sample** to be exported using the Data Entry Control, INC/DEC keys, or the numeric keypad.
3. Press the **Export** function key (F5). The screen shown above appears.
4. **Select the destination** drive, folder and bank using the cursor keys and Data Entry Control. **WAVE and AIFF formats can ONLY be exported to floppy disk.** You cannot write into an existing bank without erasing it. Usually you will choose an empty bank.
5. Select the format for the samples. Press **F2** for EIIIx, **F3** for EIV (EOS), **F4** for WAVE, or **F5** for AIFF format.
6. Press **OK** to export the sample or **Cancel** to cancel the operation.

Get Info

This function displays a sample's size in number of samples and length in seconds. It also lists the amount of memory remaining.

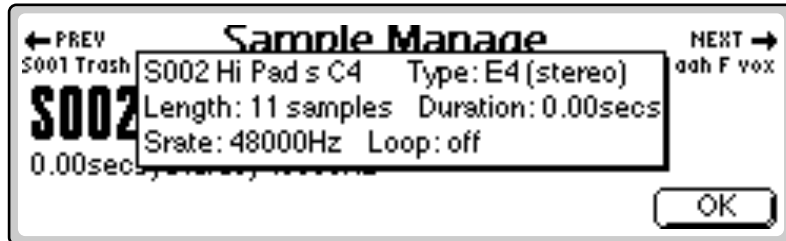

To Get Information about a Sample:

1. Press the **Sample Manage** key. The LED illuminates and the main screen appears.
2. **Select the desired sample** using the Data Entry Control, INC/DEC keys, or the numeric keypad.
3. Press the **Info...** function key (F6). A pop-up window appears with information about the sample.
4. Press the **OK** function key to return to the main Sample Manage screen.

Sample Edit

6

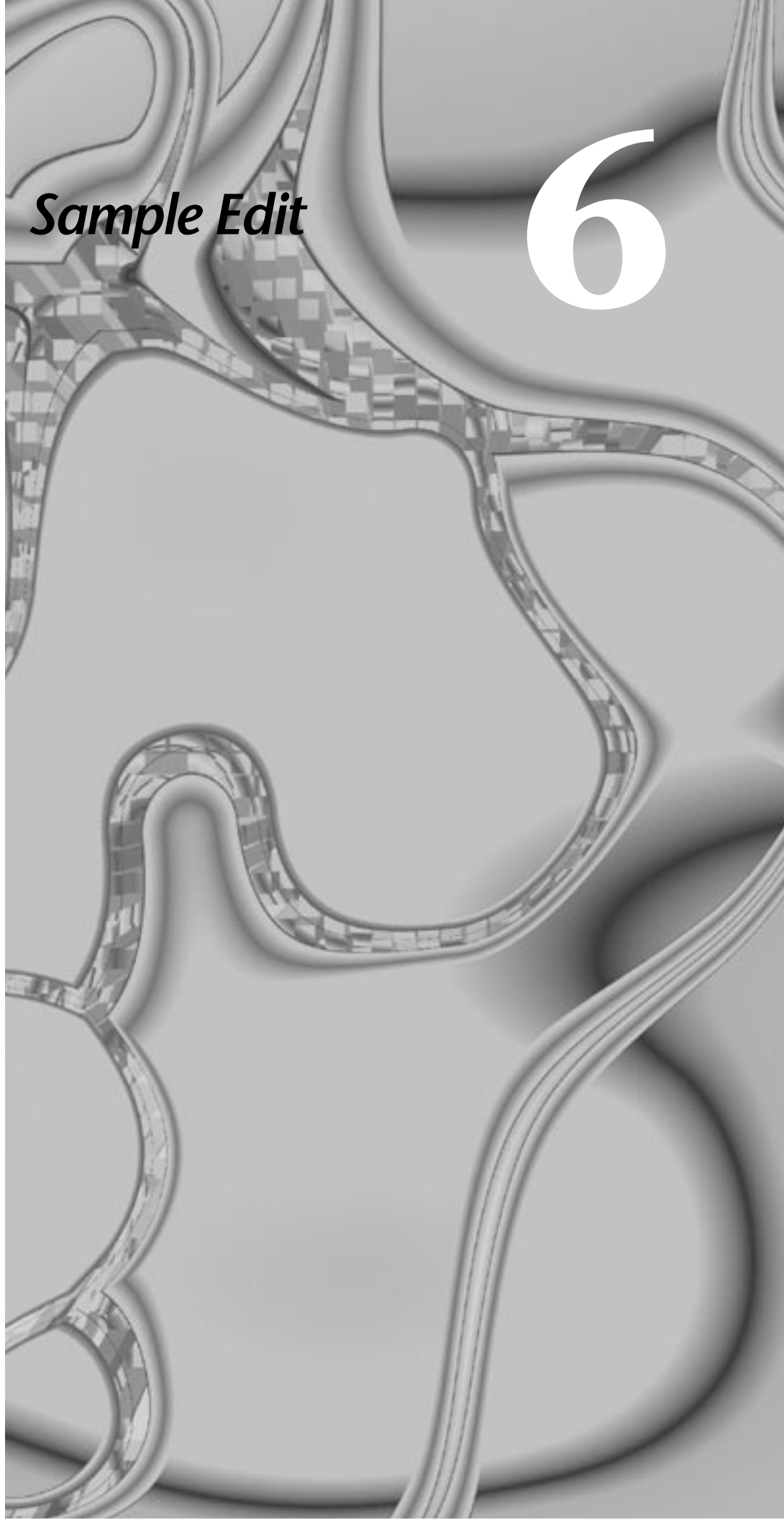

6 - Sample Edit

Sample Edit



The Sample Edit menu allows you to modify the actual sample data in order to perform functions such as: sample looping, sample truncation and splicing, equalization, time compression, sample rate conversion and many others. In the Sample Edit module we are working with the most basic element of the EOS hierarchy, the sample. It is important to note that every one of these functions except basic looping PERMANENTLY modifies the sample data. If you must maintain an original version of the sample, make a copy of the sample and edit that preserving the original.

 **Tip:** Entering the Sample Edit module resets the EOS sound engine. You can use this feature as a kind of "Panic Button" to turn off stuck MIDI notes or reset other screens. You could even set an Assignable Key to perform this function.

Any sample in the bank can be selected from the main Sample Edit screen (shown above) using the data entry control, INC/DEC keys or numeric keypad.

The Sample Edit menu contains six main submenus:

Utilities. Cut, Copy, Paste, Truncation and Taper

Tools 1. Looping Controls, Loop Type, Digital Tuning, Sample Rate Conversion, and Sample Calculator

Tools 2. DC Filter, Swap Left and Right channels, Stereo<->Mono conversion, Reverse Sample, and Sample Integrity

Tools 3. Gain Change, Compressor, Parametric EQ, FIR (Phase Linear) filter, and Aphex Aural Exciter™

Tools 4. Transform Multiplication, Doppler/Pan, Time Compression/Expansion, Pitch Change, Bit Converter, and Beat Munger

UNDO! Allows you to undo any sample editing process.

Background: The Scrub Wheel

The Scrub Wheel is a great function that allows you to use the controller's pitch wheel in many Sample Edit functions to quickly move through a sound, similar in concept to rocking the reels of a reel-to-reel tape recorder. The scrub wheel makes it easy to locate a particular section of a sound because you are able to hear the sound as you move through it.

To use the scrub wheel, move the pitch wheel of your MIDI keyboard while in a Sample Edit function such as Truncation or Looping. If the pitch wheel is moved slightly forward, the sound will play slowly through its length. If the wheel is pushed forward all the way, the sound will play through faster. If the wheel is moved backwards (towards you) the sound will play backwards through the sound. The scrub wheel operates like the accelerator on your car: the harder you press it, the faster it goes.

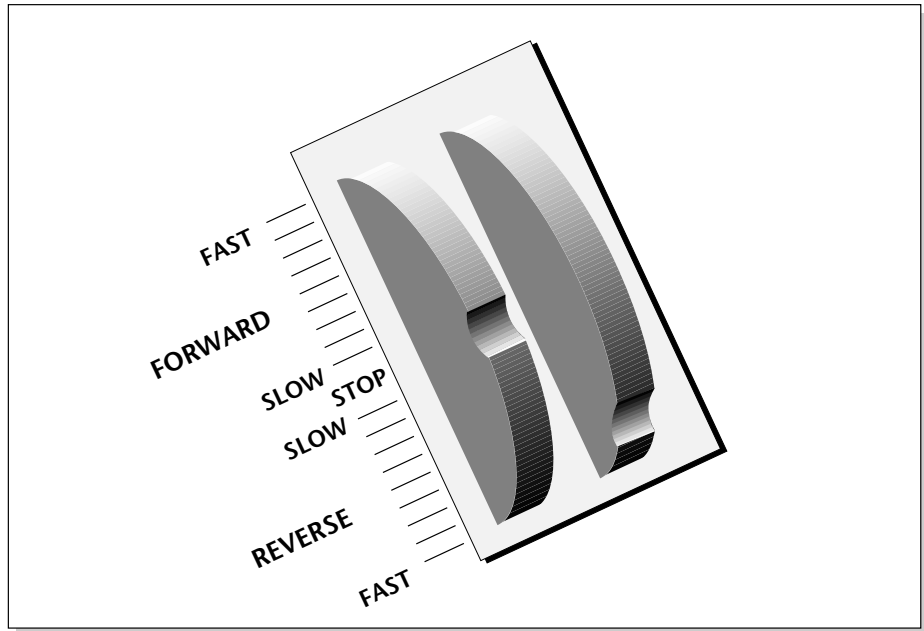

SCRUB WHEEL. Move the wheel slightly to advance slowly through the sound. Move the wheel more to advance quickly through the sound.

Background: Using Cut, Copy, Paste and Undo

Imagine a printout of a sample. Now imagine that you have a pair of scissors capable of cutting a piece out of that sample (or a copy of that piece if you don't want to affect the original), as well as a clipboard to neatly hold the cut or copied piece. Now imagine that you can either perfectly insert the clipboard contents at any given point in any sample, or mix the clipboard contents in with any sample, starting at any designated point. The Emulator can do all this, and all electronically. Auto Correlation and Crossfade functions are also provided for seamless transitions between the cut, copied, and pasted parts.

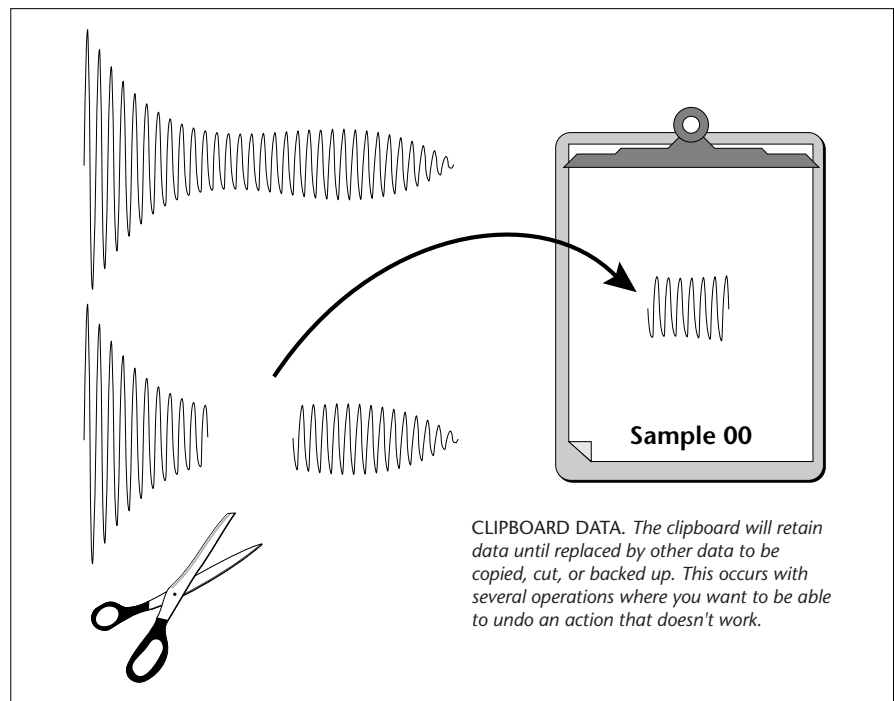

Undo and Redo

During several sample edit operations such as cut, paste, and sample rate conversion, the sample being processed will automatically be backed up and stored on the main hard disk drive. If you do not like the results of the processing, you can call up the Undo function, and restore the original sample from the main drive. (Ah, if only life itself were so simple.) Best of all, the processed sample will now move onto the main drive. Thus, if you decide you liked the processed version better after all, you can actually undo the undo. (Redo.)

Insufficient Hard Disk Drive Memory

The display will inform you if there is not enough memory to back up a sample onto the hard disk drive. You then have two choices: either free up some additional memory by erasing banks on the hard disk drive, or call up the Undo function and disable the backup process. Of course, if backup is disabled, you will not be able to undo an operation.

Typical Applications

Typical cut/copy/paste applications would be to splice the beginning of one sample to the end of another, or to mix two samples together to conserve memory. (*Do this by copying an entire sample, then pasting it at the beginning of the second sample using the mix option.*) You can splice an attack transient on to a synthesizer waveform loop to produce realistic sounds that take up virtually no memory, or take out a pop or click in a sample. Another possibility is, flanging and chorusing. Paste (mix) a sample to itself, offset from the beginning by a few hundred samples or so, to thicken up the sound.

Background: About Looping

Sampling is the process of storing sounds in digital memory. Since each individual sample (not the complete sample, but each element of the sample) requires one memory slot, memory requirements increase if you sample long sounds or use high sampling rates.

How Looping Works

Looping is a technique that can extend a sound's length without using lots of memory. It is based on the fact that many sounds start off with a complex attack transient, then settle down to a comparatively steady sound. Listen carefully to a plucked guitar string. The first part of the sound consists of a complex mixture of pick noise and several harmonics; after a while, the string decays down to a pretty steady repetitive waveform.

Since the latter part of the waveform is repetitive, there is no need to waste memory sampling several seconds of it. Instead, you can mark off a loop of the repetitive section, and play that looped section for as long as the key is held down. After playing to the end of the loop, the sound jumps back to the beginning of the loop and play through the loop again. This process repeats until you release the key playing back the sample.

Auto Correlation

First of all, just what does auto correlation mean? Auto correlation simply means automatic correlation or comparison. The computer analyzes the signal around the loop points you have specified and then moves the start or end point of the loop until it finds a section of the wave that closely matches the section around the start point. If the **Fix Size parameter is On**, the **Start point** of the loop is adjusted. If **Fix Size is Off**, the **End point** in the loop is adjusted. Auto correlation may be used again and again with the computer moving the analysis window slightly each time to try to zero in on the optimum loop.

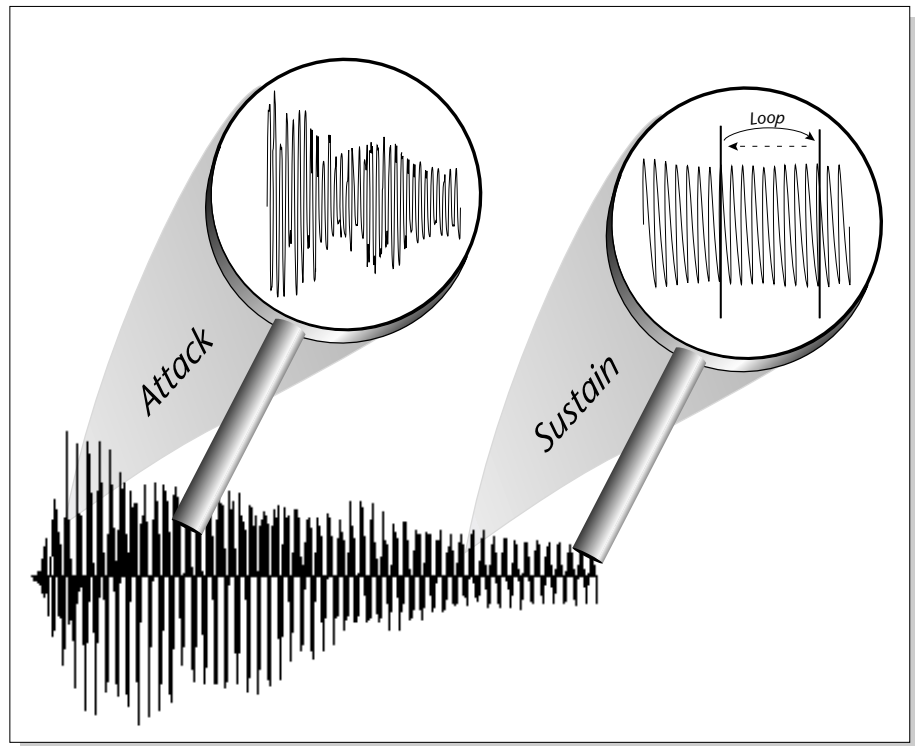

Creating Attack & Decay Characteristics for the Looped Portion

One potential problem is that the loop repeats at the same level. This is usually acceptable for sustaining instruments (flute, organ, brass, etc.), but is unacceptable for plucked or struck sounds, which decay over time. Fortunately, the Dynamic Processing module provides a means to shape the attack, sustain, and decay characteristics of a sample. You can create a decay during the looped portion, and simulate pluck or struck sounds.

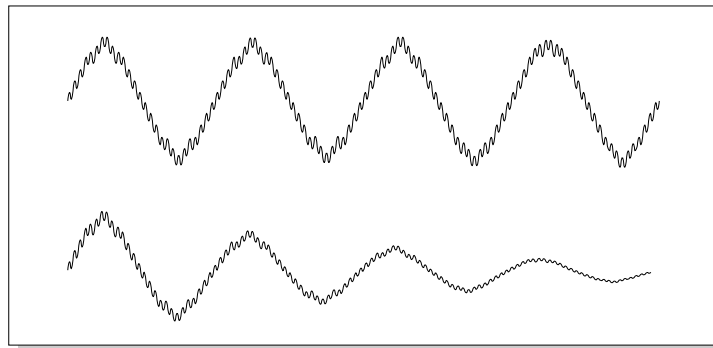

Artificial Decay can be applied to a looped sound.

Loop Compression

The looped section of the sample can be compressed, which “evens out” any changes in amplitude. Changes in amplitude can cause “breathing” effects, thumping or clicks.

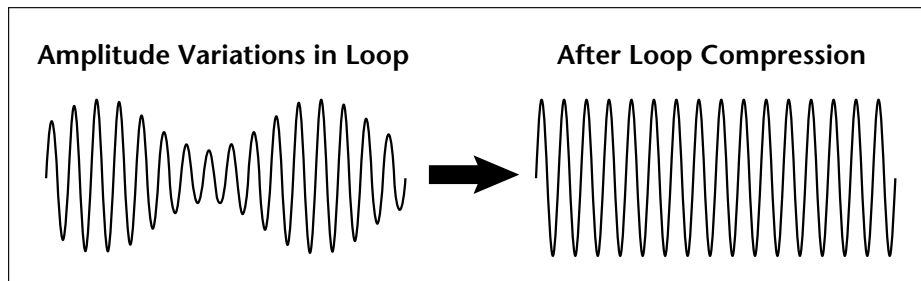



Crossfade Looping

The Emulator fades between the beginning and end of the loop so that as the end fades out, the beginning fades in. This virtually eliminates the clicks and pops that can occur with other types of looping.

 Crossfade Looping takes sound data from around the loop start point and fades it into the sound data around the loop end point so that the data at those loop points is identical.

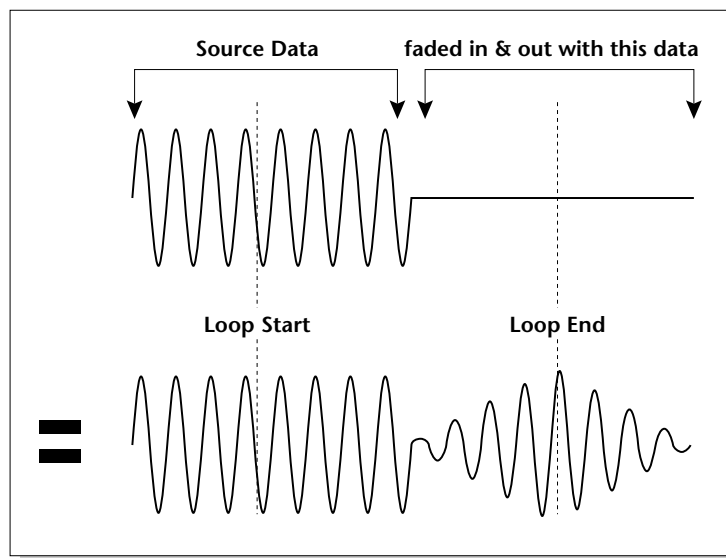
In the diagram at right, a sine wave is crossfaded with silence to illustrate the process.



 See Zero Crossing Threshold on page 88 for additional information.

Zero Crossing

The term zero crossing refers to the point at which the positive slope of a waveform passes through zero. In many sample editing applications it is useful to locate zero crossings in order to make glitch-free joins and loops. On some signals, a simple zero crossing may not be effective because the signal contains excessive noise or low-level, high-frequency harmonics. In these cases, every few samples may cross through zero. By setting a zero crossing threshold, we can ignore low-level zero crossings and wait for the signal to reach a certain level before choosing the next zero-crossing.

Utilities



The Sample Utilities menu contains several important sample editing functions.

- **Cut Section**
- **Copy Section**
- **Paste Section**
- **Truncation**
- **Taper**

Cut Section

Portions of a sample can be cut, copied, and pasted to other samples, or the samples from which they came. The Cut function removes a section of a sample, and stores the cut portion in a special part of memory called the clipboard.

🔗 To Cut a Section:

1. Press the **Sample Edit** key. The LED illuminates and the main sample edit screen appears.
2. **Select the sample** to be cut using the Data Entry Control, INC/DEC keys, or the numeric keypad.
3. Press the **Utils** function key. A second row of function keys appears.

 *The clipboard contents are designated as Sample 000.*

6 - Sample Edit Cut Section

 If the sample is stereo, a pop up dialog box will ask you to select left, right or both sides.



4. Press the **Cut** function key (F1). The following screen appears. (If the sample is stereo, you will first be asked to select the right side, left side or both.)

A visual display of the waveform appears with several controls.

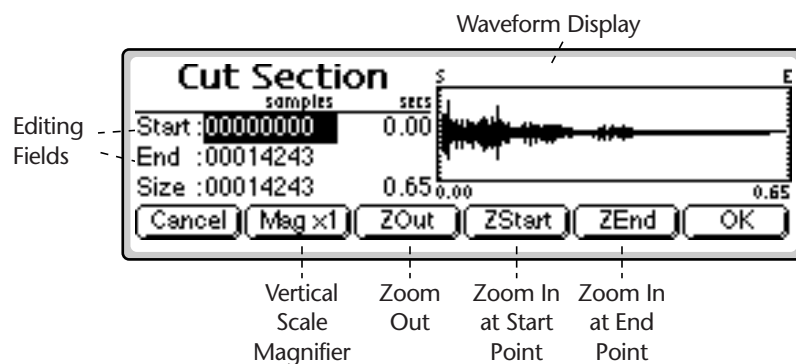

 Holding down the Enter key while turning the Data Entry Control allows "fine tuning" of the value by one number per click.

Editing Fields: Move the cursor to the desired field to change the Start and End points of the cut.

Magnification: Adjusts the vertical scale for 1x, 2x, 4x, or 8x magnification. Pressing the button repeatedly rotates through the 4 options.

Zoom Start: Magnifies the waveform to display finer detail around the Start point.

Zoom End: Magnifies the waveform to display finer detail around the End point.

Zoom Out: Reverses the effect of Zoom Start and Zoom End.

5. Specify the **Start** and **End** points for the portion of the sample to be cut.
6. The left and right cursor keys will change the start and end points so that they automatically fall on positive zero-crossing points in the waveform.
7. Press **OK** to cut the section or **Cancel** to return to the main Sample Edit screen.

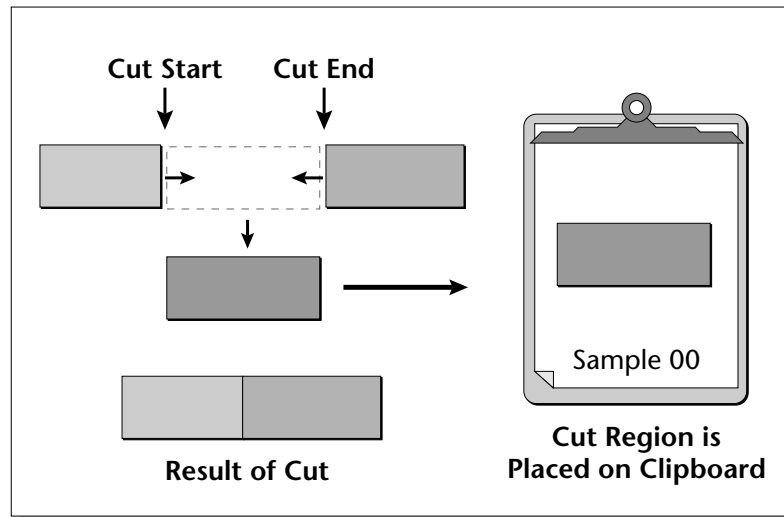

8. If you are not happy with the resulting cut or want to compare before and after, press the **Undo** function key (F6).

Copy Section

Portions of a sample can be cut, copied, and pasted to other samples, or the samples from which they came. The Copy function allows you to duplicate a section of a sample, and store that duplicate in a special part of memory called the clipboard.

To Copy a Section:

1. Press the **Sample Edit** key. The LED illuminates and the main sample edit screen appears.
2. **Select the sample** to be copied using the Data Entry Control, INC/DEC keys, or the numeric keypad.
3. Press the **Utils** function key (F1). A second row of function keys appears.
4. Press the **Copy** function key (F2). The Copy Section screen appears. (If the sample is stereo, you will first be asked to select the right side, left side or both.)
 - The Copy Section display is identical to the display in Cut Section. See Cut Section for a full description of the controls.
5. Specify the **Start** and **End** points for the portion of the sample to be copied using the Data Entry Control, left/right cursor keys, INC/DEC keys or the numeric keypad.
6. Press **OK** to cut the section or **Cancel** to return to the main Sample Edit screen.

 If the sample is stereo, a pop up dialog box will ask you to select left, right or both sides.

 The clipboard contents are designated as Sample 000.

Paste Section

Portions of a sample can be cut, copied, and pasted to other samples, or the samples from which they came. Paste takes the clipboard contents and either inserts them in a sample at a specified point, or mixes them with a sample starting at a specified point.

To Paste a Section:

1. Press the **Sample Edit** key. The LED illuminates and the main sample edit screen appears.
2. **Select the sample** that you want to paste the clipboard contents into using the Data Entry Control, INC/DEC keys, or the numeric keypad.
3. Press the **Utils** function key (F1). A second row of function keys appears.
4. Press the **Paste** function key (F3). If the sample is stereo, you will first be asked to select the right side, left side or both. The following screen appears.

 If the sample is stereo, a pop up dialog box will ask you to select left, right or both sides.

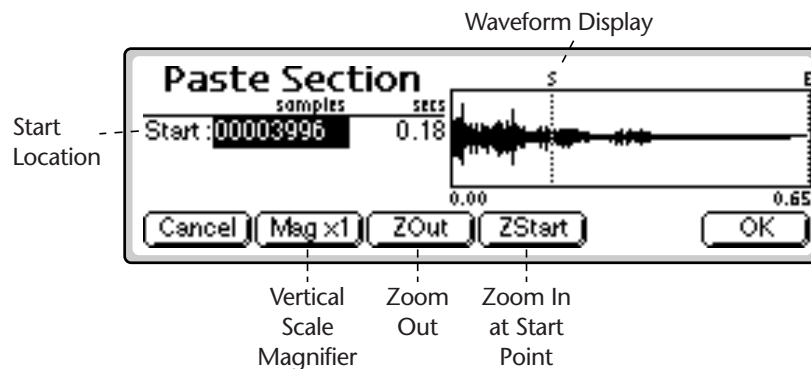

A visual display of the waveform appears with several controls.

- **Start Location:** Selects the starting location where the clipboard sample will be pasted.
 - **Magnification:** Adjusts the vertical scale for 1x, 2x, 4x, or 8x magnification. Pressing the button repeatedly rotates through the 4 options.
 - **Zoom Start:** Magnifies the waveform to display finer detail around the Start point.
 - **Zoom Out:** Reverses the effect of Zoom Start.
5. **Specify the start point** for the clipboard sample to be pasted into, then press OK. The following screen appears.



- Choose whether to insert or mix the clipboard contents at the point selected in step 5.

Insert opens up a space in the sample into which the clipboard contents fit. **Equal Power Mix** and **Linear Mix** combine the clipboard contents with existing samples, starting at the point selected in step three. Normally, you will always use Equal Power. Use Linear Mix when the signals are very similar or when Equal Power causes a gain in amplitude.

- Set the Crossfade Size and Type.

- **Equal Power:** This is a weighted crossfade that produces no apparent level shift. You will normally use this mode.
- **Linear:** This provides a straight mathematical crossfade.

- If you chose Linear or Equal Power Mix in step 6, another field in the display appears.
- You have the option to select the level of the clipboard contents to be mixed (Source Amount). 100% indicates a replacement. Refer to the following diagrams.

 The left and right cursor keys will change the start and end points so that they automatically fall on positive zero-crossing points in the waveform.

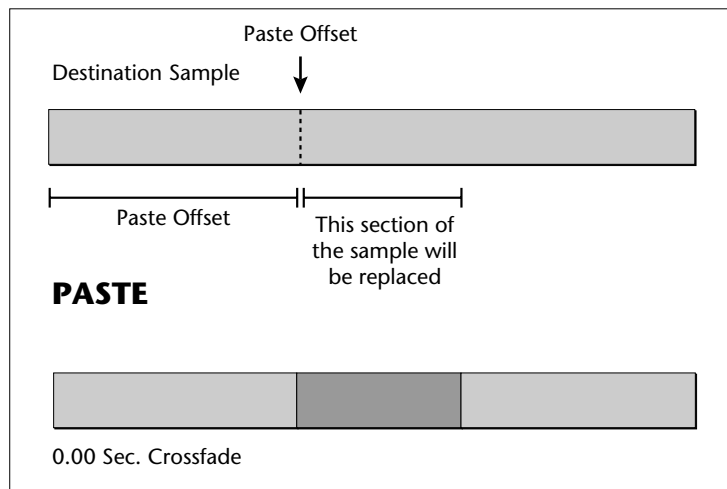

6 - Sample Edit Truncation

Mode: Mix

Source Amount = 100%

After the start point, a section of the destination is replaced with the clipboard contents.

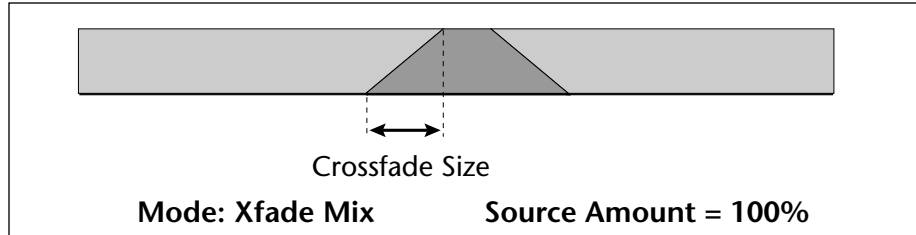

The clipboard contents will be gradually mixed into the destination sample and will replace the destination when the fade reaches 100%.

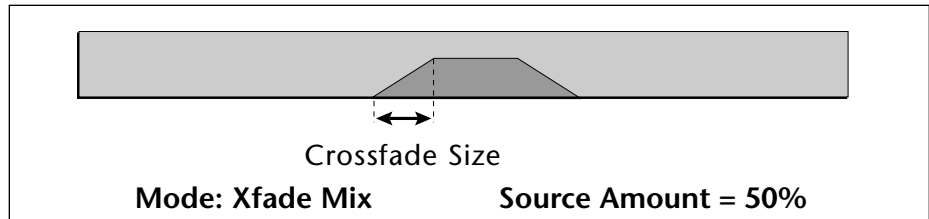

The clipboard contents will be gradually mixed into the destination sample and reach a maximum of 50-50 mix.

10. Press **OK** to paste the section or **Cancel** to return to the Sample Edit screen.

Truncation

Truncation shortens a sample's length by trimming off individual samples from the beginning and/or end. Truncation is most often used to remove unneeded portions of a sample to conserve memory, but it can also be used to change instrument characteristics such as removing the attack from a plucked string note or isolating a particular section of a sample.

To Truncate a Sample:

1. Press the **Sample Edit** key. The LED illuminates and the sample edit screen appears. Select the sample.
2. **Select the sample** that you want to paste the clipboard contents into using the Data Entry Control, INC/DEC keys, or the numeric keypad.
3. Press the **Utils** function key (F1). A second row of function keys appears.
4. Press the **Trunc** function key. The Truncation Section screen appears. (If the sample is stereo, you will first be asked to select the right side, left side or both.)



If the sample is stereo, a pop up dialog box will ask you to select left, right or both sides.

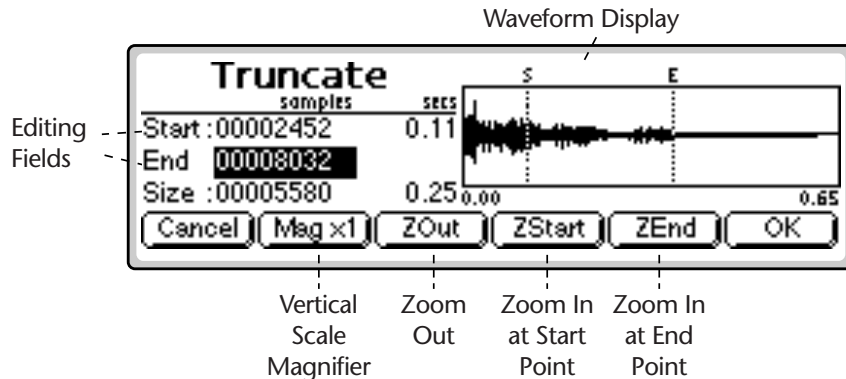

 Holding down the Enter key while turning the Data Entry Control allows “fine tuning” of the value by one number per click.

 If you aren't happy with the resulting truncation or want to compare before and after, press the Undo function key (F6).

 Taper the ends of sounds before splicing to avoid clicks or pops at the splice point.

Insure that a sample starts at 0 and that no click happens at note on by using a very short taper (-96 to 0) on the attack.

- **Editing Fields:** Move the cursor to the desired field to truncate the Start and End points of the sample.
 - **Magnification:** Adjusts the vertical scale for 1x, 2x, 4x, or 8x magnification. Pressing the button repeatedly rotates through the 4 options.
 - **Zoom Start:** Magnifies the sample to display finer detail around the Start point.
 - **Zoom End:** Magnifies the sample to display finer detail around the End point.
 - **Zoom Out:**Reverses the effect of Zoom Start and Zoom End.
5. **Specify the start and end points** for the sample truncation using the Data Entry Control, left/right cursor keys, INC/DEC keys or the numeric keypad.

Taper

Taper lets you create an artificial decay on percussion samples where the original decay is absent, create an artificial fast attack (such as bowed violin with a slow attack), or clean up background noise when editing dialog.

To Taper a Sample:

1. Press the **Sample Edit** key. The LED illuminates and the sample edit screen appears. Select the sample.
2. **Select the sample** that you want to taper using the Data Entry Control, INC/DEC keys, or the numeric keypad.
3. Press the **Utils** function key (F1). A second row of function keys appears.
4. Press the **Taper** function key. The Taper Section screen appears. (If the sample is stereo, you will first be asked to select the right side, left side or both.)

6 - Sample Edit Taper

 The Taper display is identical to the display in Truncate. See Truncate for a full description of the controls.

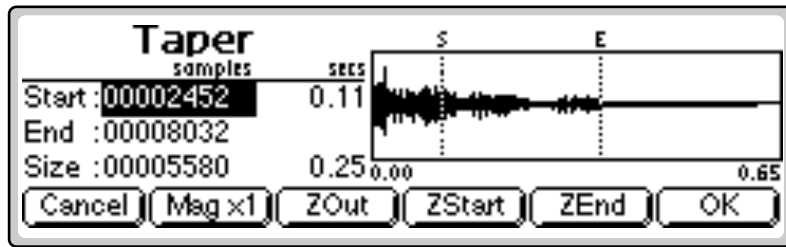

5. Specify the **Start** and **End** points for the portion of the sample to be tapered using the Data Entry Control, left/right cursor keys, INC/DEC keys or the numeric keypad.
6. Press **OK** to continue on to the next page of options or **Cancel** to cancel the operation.

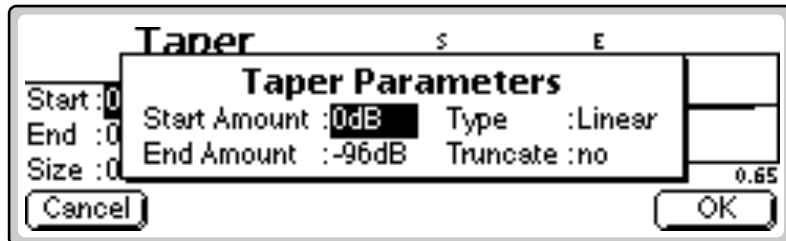

 The left and right cursor buttons will change the start and end points so that they fall on positive zero-crossing points in the waveform.

Several more tapering parameters are shown.

- **Start Amount:** This is the amount of attenuation or gain applied at the start of the selected section. Variable from -96 dB to +96 dB.
 - **End Amount:** This is the amount of attenuation or gain applied at the end of the selected section. Variable from -96 dB to +96 dB.
 - **Type:** Selects the type of curve: Linear, Exponential 1, Exponential 2, Exponential 3.
 - **Truncate:** (After Taper) Discards any information after the taper end point in order to conserve memory.
7. Specify the taper parameters using the Data Entry Control, or the INC/DEC keys.
 8. Press **OK** to taper the sample or **Cancel** to cancel the operation.

Tools 1



This submodule contains the basic digital processing tools listed below.

Looping: Looping repeats a section of the sample continuously as long as the key is held. This allows a short sample to sustain indefinitely.

Digital Tuning: Digitally retunes a sample within a range of ± 1 octave.

Sample Rate Convert: Converts the sample to any sample rate between 7000 Hz and 200000 Hz.

Sample Calculator: A handy utility to help you calculate the sample rates needed for perfect single-cycle loops.

Loop

If you have a difficult time finding good loop points, the Auto Correlation function can assist you. If Auto Correlation doesn't produce acceptable results, the beginning and end of a loop can be crossfaded to help mask loop discontinuities. For more information, see "About Looping" at the beginning of this section.

- Adjust the zero crossing threshold according to the type of wave you are looping. A setting of -96 dB is most sensitive and can be used for finding the start point of a sound. Settings closer to -30 dB are less sensitive and suited for finding zero-crossings in complex waves. See Zero Crossing Threshold on page 88 for more information.

To Set the Loop Points

1. Press the **Sample Edit** key. The LED illuminates and the main sample edit screen appears.
2. **Select the sample** that you want to loop using the Data Entry Control, INC/DEC keys, or the numeric keypad.

6 - Sample Edit Loop

3. Press the **Tools 1** function key (F2). Another row of function keys appears.
4. Press the **Loop** function key (F1). The following screen appears.

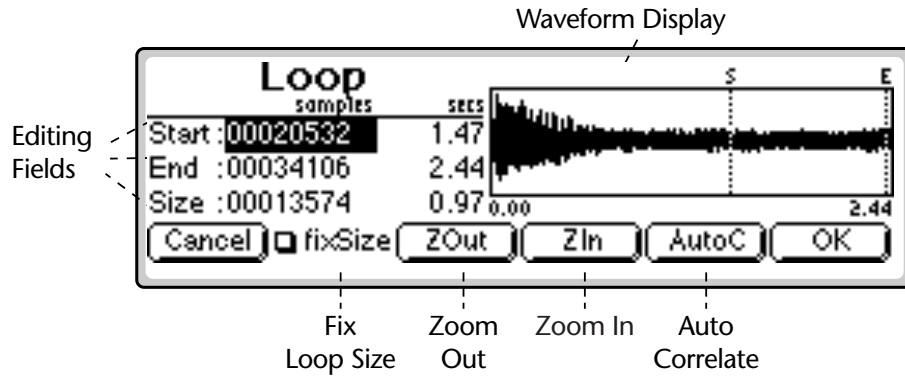

- **Editing Fields:** Move the cursor to the desired field to change the Start, End or Size of the loop. The Loop Start Loop End and Loop Size parameters can be independently changed. Press the **Fix Size** button to keep the loop size constant.

Fix Size Button: When the box is checked, the Loop Size parameter is locked at the current value. This is handy when you have found the right size loop and are looking for a better start point.

Fix Size is very useful for creating groove loops and single cycle loops.

- **Auto Correlate:** Analyzes the waveform to find likely loop points. With **Fix Size On**, the **Start Point** of the Loop is adjusted. With **Fix Size Off**, the **End Point** is adjusted.
- **Zoom In:** Magnifies the waveform to display fine detail and brings up the loop window.
- **Zoom Out:** Reverses the effect of Zoom In and displays the entire sample.

When you Zoom In on the waveform, the Loop Window appears. The loop window magnifies the splice point of the loop as shown by the bracketed area in the diagrams below.



The line in the center of the magnified loop window shows the exact splice point of the loop. You can use the left and right cursor keys to select zero-crossings for the loop start.

 *Looping is an art which takes a bit of practice to learn. Auto Correlate works best when you have already found a fairly good loop point by ear. Several different types of tools are provided to help you loop almost any sound.*

5. Press the **Auto Correlate** function key (F5) if you want help in finding likely loop points.
6. Press **OK** when you have a good loop. The following screen appears with several more looping tools.

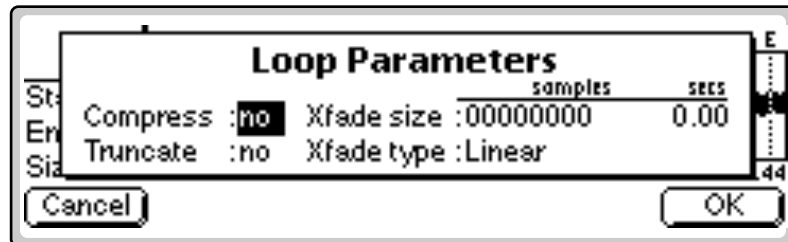

 Use larger crossfade loop sizes with complex sounds; shorter sizes when you simply want to mask a slight tick in the loop.

- **Compress Loop:** Compression “evens out” the level changes during the loop portion which are perceived as amplitude modulation or “breathing” effects.
- **Truncate:** (After Loop) Discards any information after the loop end point in order to conserve memory.
- **Crossfade Size:** (Crossfade Loop) This function smoothly crossfades between the waves on either side of the loop so that the waveform at the loop point is identical. Since Crossfade Looping alters the sound data, you may notice timbral or amplitude variations. A size of 0.00 disables crossfade looping.

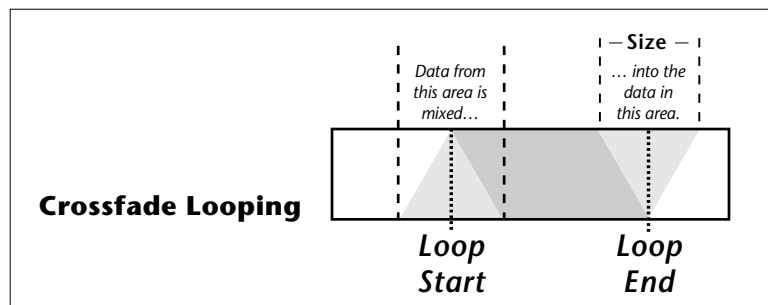

 You cannot Undo loop points.

- **Crossfade Type - Equal Power:** This is a weighted crossfade that produces no apparent level shift, and is the commonly used mode.
 - **Crossfade Type - Linear:** This provides a straight mathematical crossfade. Use linear mode with samples whose splice points are already close to optimum, such as a sample that has already been auto correlated.
7. Press **OK** to perform the operations or continue. Press **Cancel** to cancel the loop operation.



Samples imported from the E111 having forwards/backwards loops will play back on the Ultra. However, the loop data will be permanently modified to contain the forwards/backwards sound data. Changing the loop points on imported forwards/backwards loops could have unpredictable results and is not recommended.

Loop Type

This submenu allows you to turn looping On or Off and to select whether the Loop in Release function is On or Off.

To Set the Loop Type

1. Press the **Sample Edit** key. The LED illuminates and the main sample edit screen appears.
2. **Select the sample** that you want to loop using the Data Entry Control, INC/DEC keys, or the numeric keypad.
3. Press the **Tools 1** function key (F2). Another row of function keys appears.
4. Press the **LpType** function key (F2). The following screen appears.

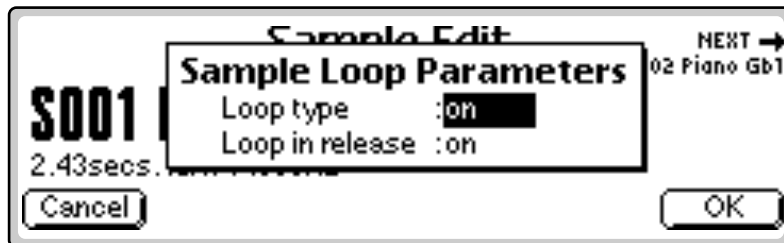

5. Select **Loop Type** as either On or Off.
 - **Off:** The loop is disabled and the sample plays as recorded.
 - **On:** The sample plays normally until it reaches the end of the loop. It then jumps back to the start point and replays through the loop. Upon reaching the loop end, it again replays the loop. This looping process continues for as long as the key is pressed.
6. Select whether **Loop in Release** is On or Off.
 - **Off:** Lifting your finger off a key initiates the release phase of the amplifier envelope in the voice. If Loop in Release is off, the loop will not continue during the release phase. The portion of the sample after the loop will be played during release. The signal may cut off abruptly after you remove your fingers from the keys if the sample has been truncated after the loop.
 - **On:** With Loop in Release on, the loop keeps playing—even after you lift your finger off the key—for the duration of the amplifier envelope release.
7. Press **OK** to enter the new values or **Cancel** to cancel your changes.

 Try offsetting the pitch of a copied sample by a few cents, then combine it with the original for flange and chorus effects.

Digital Tuning

Digital Tuning allows you to change the pitch of a sound in order to splice or combine it with another sound of a different pitch. If a sample is slightly out of tune, it is usually better to fix the sample once and for all, rather than re-tuning the sample every time it is placed on the keyboard.

- **Filtering** - Digital Tuning utilizes a low pass filter to prevent aliasing in the output. Filtering is automatically applied depending on the amount of tuning, but the three ranges allow you to have more control over the output.

- **Crunchy** - Least amount of filtering - High frequency content retained, but sample may contain audible artifacts.
- **Smooth** - Medium amount of lowpass filtering.
- **Creamy** - Maximum amount of lowpass filtering - Some high frequencies will be removed.

To Retune a Sample

1. Press the **Sample Edit** key. The LED illuminates and the main sample edit screen appears.
2. **Select the sample** that you want to tune using the Data Entry Control, INC/DEC keys, or the numeric keypad.
3. Press the **Tools 1** function key (F1). Another row of function keys appears.
4. Press the **DigTune** function key (F3). The following screen appears.

 If the sample is stereo, a pop up dialog box will ask you to select left, right or both sides.



 Re-tuning pitch downward increases the sample size. Re-tuning pitch upwards decreases the sample size.

5. **Enter the tuning amount** in cents using the Data Entry Control, or INC/DEC keys. The new sample size and new loop size will be calculated.
6. Press **OK** to retune the sample or **Cancel** to cancel the operation.

Sample Rate Convert

Sampling at a high sample rate provides better frequency response than sampling at a slower rate, but uses up more memory. If you need to reclaim some of that memory, and are willing to trade off sample frequency response, samples can be converted from a higher rate to a lower one. Use your ear to compare sounds at the two sample rates. If you can't tell the difference, use the lower rate.

Sample Rate Conversion can be used for saving memory, increasing the upward transposition range of a sound, or exactly matching the sample rate to a multiple of the sound's frequency for perfect single cycle loop.

- Set the built-in sample calculator to the note you want to loop and it automatically calculates the number of samples in a single cycle loop.
- **Filtering** - Sample rate converters contain a low pass filter to prevent aliasing in the output. While the amount of filtering is automatically applied depending on the amount of change, three ranges of low pass filtering are provided to allow you more control over the output.

- **Crunchy** - Least amount of filtering - High frequency content retained, but sample may contain audible artifacts.
- **Smooth** - Medium amount of lowpass filtering.
- **Creamy** - Maximum amount of lowpass filtering - Some high frequencies will be removed.

To Change the Sample Rate

1. Press the **Sample Edit** key. The LED illuminates and the main sample edit screen appears.
2. **Select the sample** that you want to process using the Data Entry Control, INC/DEC keys, or the numeric keypad.
3. Press the **Tools 1** function key (F2). Another row of function keys appears.
4. Press the **SrCnv** function key (F4). The following screen appears.

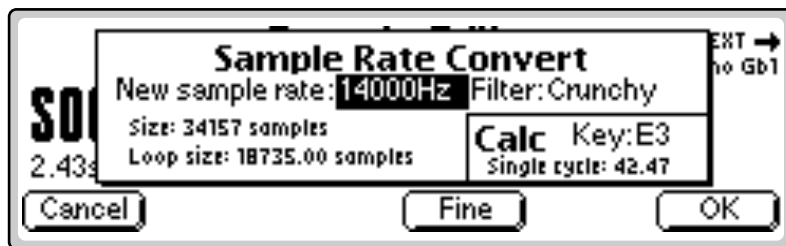

5. **Enter the new sample rate** using the Data Entry Control, INC/DEC keys, or the numeric keypad. The new sample size and new loop size will be calculated.

 To use the mini sample calculator, simply move the cursor down to the Key field and use the Data Entry Control to set the note. The calculator will display the number of samples in a single cycle loop at the selected sample rate. Select a sample rate where the single cycle loop has an integer value only.

 If you are not happy with the resulting conversion or want to compare before and after, press the Undo function key (F6).

- **Coarse/Fine** - Fast forward through the values using Coarse, then switch to Fine for single digit editing.
6. Set the low pass filter to the desired range: Crunchy, Smooth or Creamy.
 7. Press **OK** to change the sample rate or **Cancel** to cancel the operation.

Sample Calculator

Use the sample calculator to compute sample rates for perfect single cycle loops. If the single-cycle value shown is not an integer number, adjust the sample rate value so that it does become an integer number, then use the Sample Rate Convert function to convert the sample to the new rate.

To Use the Sample Calculator:

1. Press the **Sample Edit** key. The LED illuminates and the main sample edit screen appears.
2. **Select the sample** that you want to process using the Data Entry Control, INC/DEC keys, or the numeric keypad.
3. Press the **Tools 1** function key (F2). Another row of function keys appears.
4. Press the **Calc** function key (F6). The following screen appears

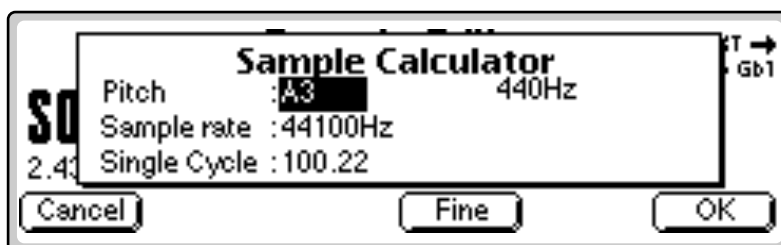

5. **Select the known pitch** of the sample using the keyboard, INC/DEC keys or the Data Entry Control.
6. **Select the sample rate** using the INC/DEC keys or the Data Entry Control. The number of samples for a single-cycle loop changes for each sample rate.
 - **Coarse/Fine** - Fast forward through the values using Coarse, then switch to Fine for single digit editing.
 - **Frequency Indicator** - Displays the fundamental frequency of the selected note.
7. Press **OK** or **Cancel** to return to the Sample Edit screen.

Tools 2

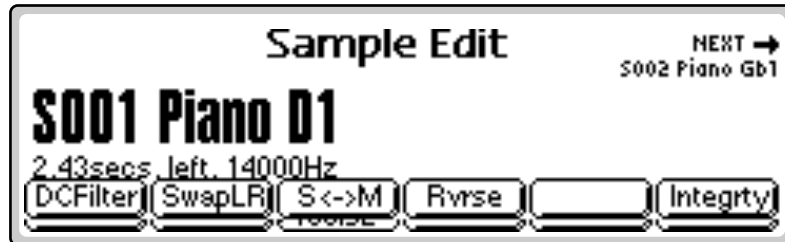

This submodule contains the basic digital processing tools listed below.

DC Filter: Removes the DC component from a sample, centering the waveform around the zero axis.

Swap L/R: Swaps the left and right sides of a stereo sample

Stereo<->Mono Conversion: Converts stereo samples to mono and vice-versa.

Reverse Sample: Reverses all or part of a sample.

Sample Integrity: Remedies looping problems in imported samples.

DC Filter

Removes the DC component from a sample, centering the waveform around the zero axis. The positive and negative peaks of the sample are expressed in 16 bit samples. Full scale for a 16-bit sample is ± 32767 . Use the peak values to see how close you are to full scale. If one of the peaks is too close to 32767, DC Filtering may cause the signal to clip. Mean is the DC bias present in the sample. The lower the number, the less bias is present.

To DC Filter:

1. Press the **Sample Edit** key. The LED illuminates and the main sample edit screen appears.
2. **Select the sample** that you want to DC Filter using the Data Entry Control, INC/DEC keys, or the numeric keypad.
3. Press the **Tools 2** function key (F3). A second row of function keys appears.
4. Press the **DC Filter** function key (F1). The following screen appears.



If the sample sounds clipped after DC Filtering, Undo, then attenuate the sample by 2 dB. Next, DC Filter the sample and Normalize using Change Gain.



5. Press **OK** to DC Filter or **Cancel** to cancel the operation.

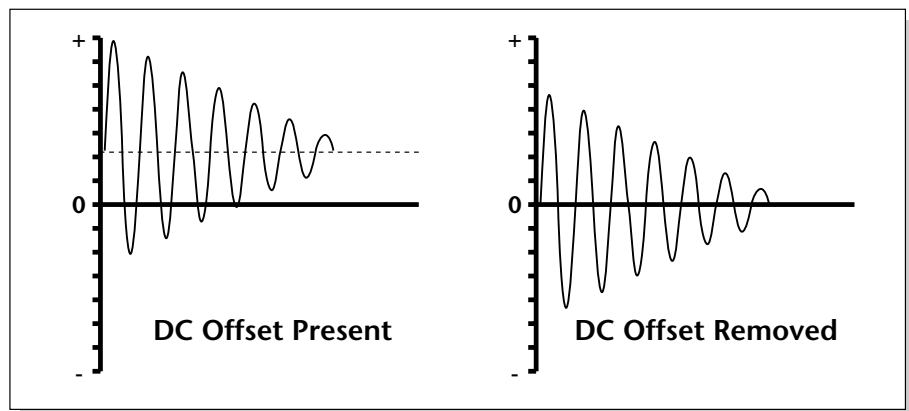

Swap Left & Right

Swaps sides of a stereo sample or moves a mono sample to the other side.

To Swap Sides:

1. Press the **Sample Edit** key. The LED illuminates and the main sample edit screen appears.
2. **Select the sample** that you want to swap using the Data Entry Control, INC/DEC keys, or the numeric keypad.
3. Press the **Tools 2** function key (F3). Another row of function keys appears.
4. Press the **SwapLR** function key (F2). A pop up display will ask you to confirm the operation.
5. Press **OK** to swap the selected sample or **Cancel** to cancel the operation.

Stereo <-> Mono

Converts a stereo sample to mono or a mono sample to stereo. Converting to stereo duplicates the sample on both sides and slightly detunes them. Converting to mono sums both sides of the stereo sample, then divides by two.

To Convert a Sample:

1. Press the **Sample Edit** key. The LED illuminates and the main sample edit screen appears.
2. **Select the sample** that you want to convert using the Data Entry Control, INC/DEC keys, or the numeric keypad.
3. Press the **Tools 2** function key (F3). Another row of function keys appears.
4. Press the **S <-> M** function key (F3). A pop up display will ask you to confirm the operation.
5. Press **OK** to convert the selected sample or **Cancel** to cancel the operation.

Reverse Section

Reverses all or part of a sample.

To Reverse a Sample:

1. Press the **Sample Edit** key. The LED illuminates and the main sample edit screen appears.
2. **Select the sample** that you want to reverse using the Data Entry Control, INC/DEC keys, or the numeric keypad.
3. Press the **Tools 2** function key (F3). Another row of function keys appears.
4. Press the **Revse** function key (F4). The following screen appears.

 If the sample is stereo, a pop up dialog box will ask you to select left, right or both sides.

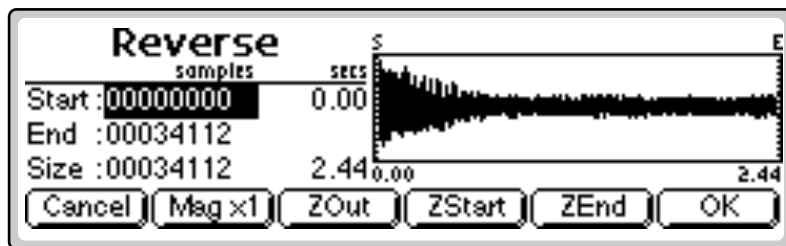

- The Select Section display controls are identical to the controls in Truncate. See Truncate for a full description of the controls.



The Start and End points are “remembered” from module to module so that you can perform successive operations on the same section of the sample.

5. Specify the **Start** and **End** points for the portion of the sample to be reversed using the Data Entry Control, left/right cursor keys, INC/DEC keys or the numeric keypad.
 - The left and right cursor buttons will change the start and end points so that they fall on positive zero-crossing points in the waveform. This will minimize clicks in the sound when processing only part of a sample.
6. Press **OK** to reverse the section or **Cancel** to cancel the operation.

Sample Integrity

Imported samples may occasionally have slight looping problems (heard as ticks) due to data corruption of the sample header file. This function remedies the problem by reconstructing the sample header.

To Fix all Samples:

1. Press the **Sample Edit** key. The LED illuminates and the main sample edit screen appears.
2. Press the **Tools 2** function key (F3). A second row of function keys appears.
3. Press the **Integrty** function key (F6). You are asked, “Fix all Samples?”.
4. Press **OK** to fix all samples in the bank or **Cancel** to return to the Sample Edit screen.

Tools 3



This submodule contains the digital processing tools listed below.

- **Gain Change:** Alters the level of all or part of a sample.
- **Compression:** The compressor dynamically changes the gain of the sample based on the amplitude envelope of the sample. This is a non-real-time implementation of a full featured dynamic range compressor.
- **Parametric Equalization:** This is a digital (non real-time) implementation of a one band parametric EQ, with +12 dB boost or -48 dB of cut and completely variable frequency and bandwidth controls.
- **FIR:** Phase-linear Lowpass, Highpass, and Bandpass filters with extremely steep cutoff slopes and Q.
- **Aphex Aural Exciter:** This function adds brilliance and “cut” to a sample, helping it to stand out in a mix. The Aphex Exciter works by adding high order harmonics related to the source material.

Gain Change

Gain Change alters the level of all or part of a sample.

To Change the Gain of a Sample:

1. Press the **Sample Edit** key. The LED illuminates and the main sample edit screen appears.
2. **Select the sample** that you want to Gain Change using the Data Entry Control, INC/DEC keys, or numeric keypad.
3. Press the **Tools 3** function key (F4). Another row of function keys appears.
4. Press the **Gain** function key (F1). The following screen appears.

 If the sample is stereo, a pop up dialog box will ask you to select left, right or both sides.

 The Start and End points are "remembered" from module to module so that you can perform successive operations on the same section of the sample.

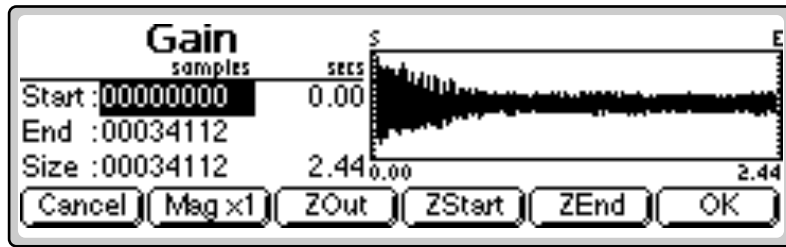

- The Gain Change display is identical to the display in Truncate. See Truncate for a full description of the controls.
5. Specify the **Start** and **End** points for the selected portion of the sample using the Data Entry Control, left/right cursor keys, INC/DEC keys or the numeric keypad.
 6. Press **OK** to continue on to the next page of options or **Cancel** to cancel the operation.

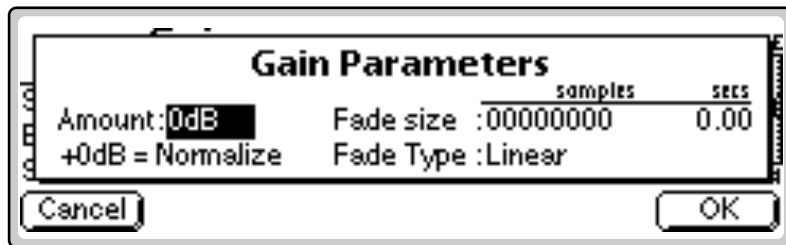

Several more parameters are shown.

- **Amount:** This is the amount of attenuation or gain applied to the selected section and is also variable from -96 dB to +96 dB.
- **Normalize:** This is a display showing the amount of gain change needed to achieve normalization or 0 dB headroom. Adding more positive gain change than the amount shown in the normalize display will cause the signal to clip.
- **Fade Size:** Set the length of the crossfade between the unaffected sample and the full amount of gain change.
- **Fade Type:** Selects the type of fade curve: Linear, Exp. 1, Exp. 2, Exp. 3. The graphs of these curves are shown on the following page.

 If you are not happy with the resulting gain change or want to compare before and after, press the Undo function key (F6).

6 - Sample Edit Gain Change

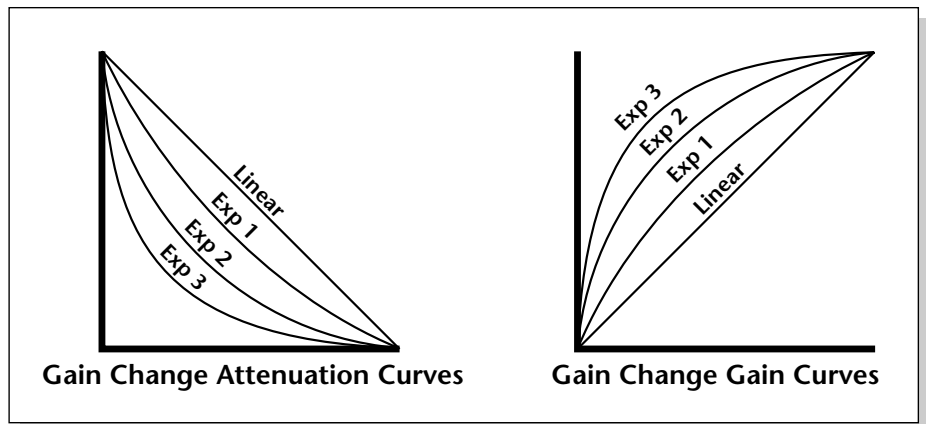

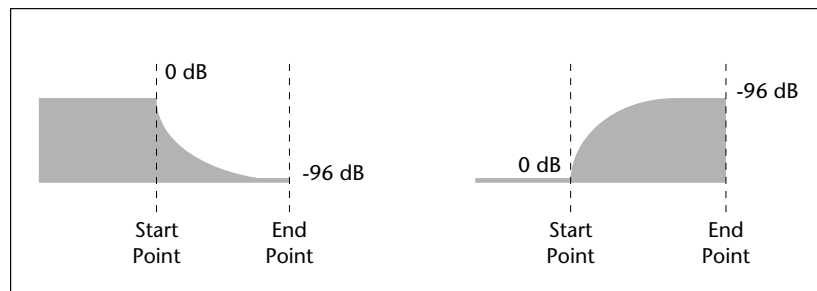

7. Specify the **gain change** parameters using the Data Entry Control, or the INC/DEC keys.
8. Press **OK** to change the gain of the sample section or **Cancel** to cancel the operation.



Gain fade-out and fade-in using the exponential 3 curve.

 The Start and End points are “remembered” from module to module so that you can perform successive operations on the same section of the sample.

 If the sample is stereo, a pop up dialog box will ask you to select left, right or both sides.

 Holding down the **Enter** key while turning the Data Entry Control allows “fine tuning” of the value by one number per click.

- The **Zoom** controls also change the editing resolution.

Compressor

The Digital Compressor is a digital (non-realtime) equivalent of an analog dynamic range compressor with attack and release times, adjustable threshold, adjustable ratio, and three modes of operation.

To Compress a Sample:

1. Press the **Sample Edit** key. The LED illuminates and the main sample edit screen appears.
2. **Select the sample** that you want to compress using the Data Entry Control, INC/DEC keys, or the numeric keypad.
3. Press the **Tools 3** function key (F4). Another row of function keys appears.
4. Press the **Comprsr** function key (F2). The following screen appears. A waveform display appears with several controls.

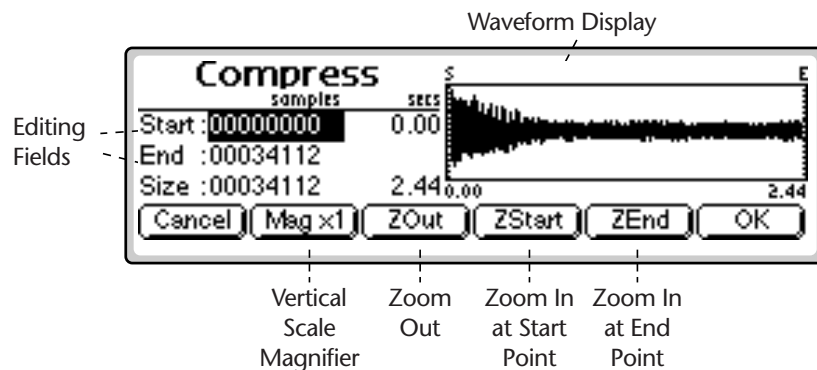

- **Editing Fields:** Move the cursor to the desired field to change the Start and End points of the sample section to be compressed.
 - **Magnification:** Adjusts the vertical scale for 1x, 2x, 4x, or 8x magnification. Pressing the button repeatedly rotates through the 4 options.
 - **Zoom Start:** Magnifies the waveform to display finer detail around the Start point of the selected section.
 - **Zoom End:** Magnifies the waveform to display finer detail around the End point of the selected section.
 - **Zoom Out:** Reverses the effect of Zoom Start & Zoom End.
5. Specify the **Start** and **End** points for the section of the sample to be processed.
 6. Press **OK** when you have selected the desired section or press **Cancel** to cancel the operation.

7. If you pressed OK, the following screen appears.

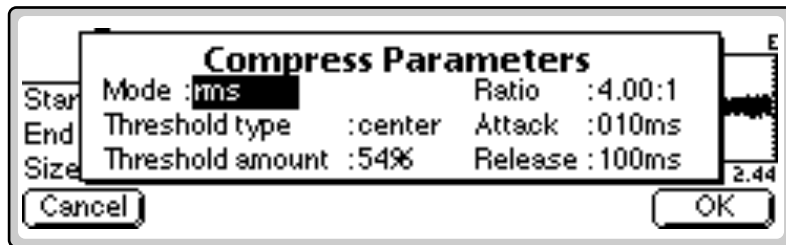

Mode

- **RMS:** Root-mean-square or an “average of the magnitude of the signal”. RMS represents the “true” energy content of a signal.
- **Peak:** Uses the peak amplitude of a signal to determine the amplitude. The peak amplitude is a meaningful measurement in a digital system because of the 96 db (16-bit) headroom limit.

Threshold

- **Above:** Only signal levels above the threshold % will be affected by the compressor.
- **Center:** Signal levels above as well as below the threshold % will be affected by the compressor.
- **Below:** Only signal levels below the threshold % will be affected by the compressor.
- **%:** Determines the threshold level as a percentage of 100% of 16-bits.

Compression Ratio

Determines the amount of compression or expansion. Ratios of greater than 1:1 compress dynamic range. Ratios of less than 1:1 expand dynamic range.

- **Compression:** Reduces the amount of dynamic range. Levels remain more constant.
- **Expansion:** Expands the amount of dynamic range. Changes in level are exaggerated.

Attack Time

Determines how quickly the gain will be turned down. The attack time is variable from 1 to 999 milliseconds.

Release Time

Determines how quickly the gain will be turned up. The release time is variable from 1 to 999 milliseconds.

- Press OK when you have set the desired options or press Cancel to cancel the operation.

Only signal levels ABOVE the Threshold percentage will be affected by the compressor.

Signal levels ABOVE as well as BELOW the Threshold percentage will be affected by the compressor.

Only signal levels BELOW the Threshold percentage will be affected by the compressor.

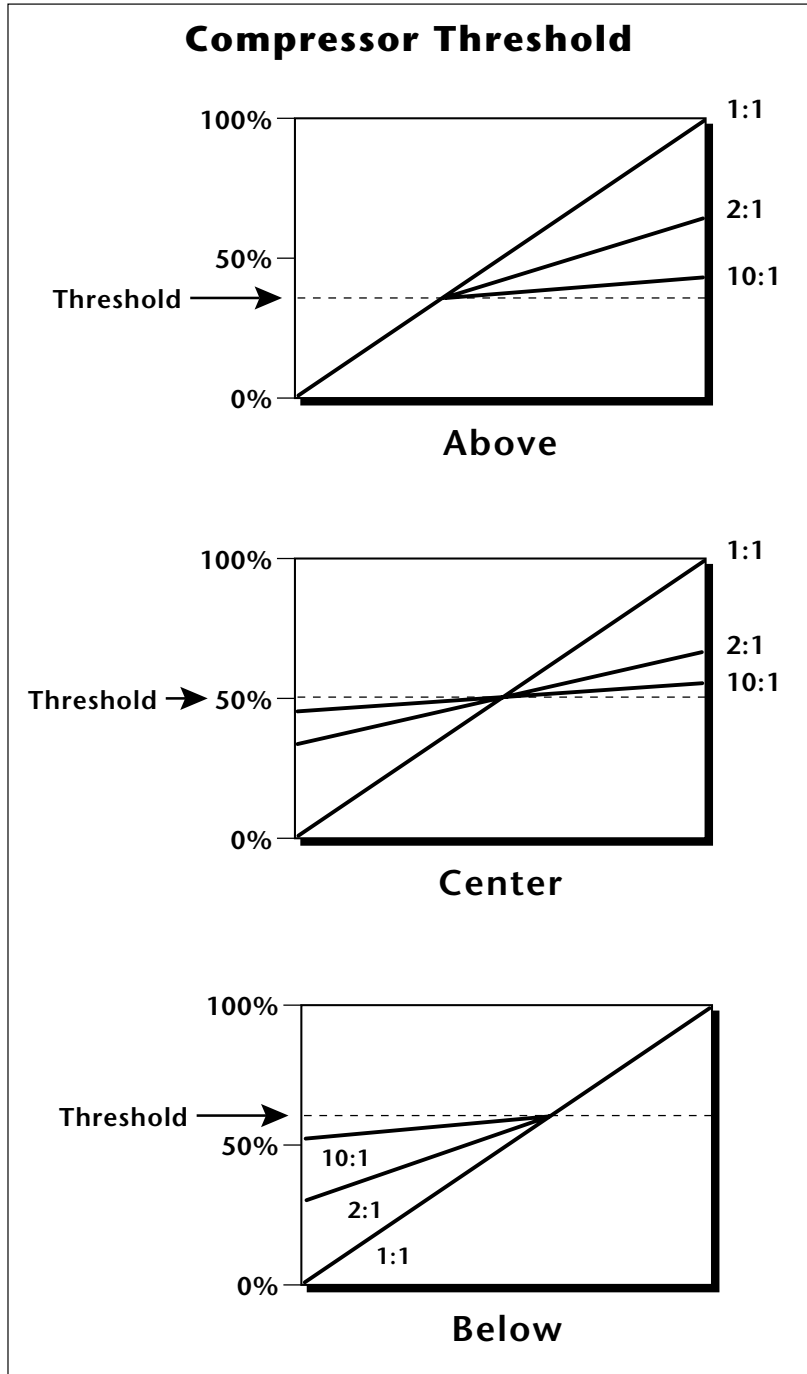

Using the Digital Compressor

Limiter

A limiter prevents the signal from exceeding a preset level (threshold). Signal levels below the threshold will be unaffected.

Set the controls as follows:

Threshold: Above, XX% (where XX is the limit point).
Ratio: >10:1
Attack Time: 1 mS
Release Time: approximately 100 mS

Musical Compression (e.g. Guitar)

This type of compression tries to keep the volume constant, generally to increase the sustain of the instrument. As the note dies away, the compressor will boost the level in an effort to keep the level constant.

Set the controls as follows:

Threshold: Center, XX% (where XX is the compression point).
Ratio: approximately 4:1
Attack Time: 1 mS to 100 mS
Release Time: > 100 mS

Noise Reduction

Noise reduction will reduce low levels even further in the assumption that low levels are noise.

Set the controls as follows:

Threshold: Below, approximately. 30%
Ratio: approximately 0.7:1
Attack Time: approximately 100 mS
Release Time: approximately 100 mS

Parametric Equalizer

 The Start and End points are “remembered” from module to module so that you can perform successive operations on the same section of the sample.

 The left and right cursor buttons will change the start and end points so that they fall on positive zero-crossing points in the waveform. This will minimize clicks in the sound when processing only part of a sample.

 If the sample is stereo, a pop up dialog box will ask you to select left, right or both sides.

 Holding down the Enter key while turning the Data Entry Control allows “fine tuning” of the value by one number per click.

Parametric EQ allows you adjust the individual parameters of the filter. Boost/Cut controls “how much” of the signal will be boosted or cut. Center Frequency sets the center frequency to be boosted or cut, and the Bandwidth control sets the width of the band to be boosted or cut. The three parameters are diagrammed on the following page.

The parametric equalizer is a digital (non real-time) equivalent of an analog equalizer with +12 dB of boost and a whopping -48 dB of cut. Center frequency and bandwidth controls are accurate, precise and have an exceptionally wide range.

To Filter a Sample:

1. Press the **Sample Edit** key. The LED illuminates and the main sample edit screen appears.
2. **Select the sample** that you want to equalize using the Data Entry Control, INC/DEC keys, or the numeric keypad.
3. Press the **Tools 3** function key (F4). Another row of function keys appears.
4. Press the **ParEQ** function key (F3). The following screen appears.

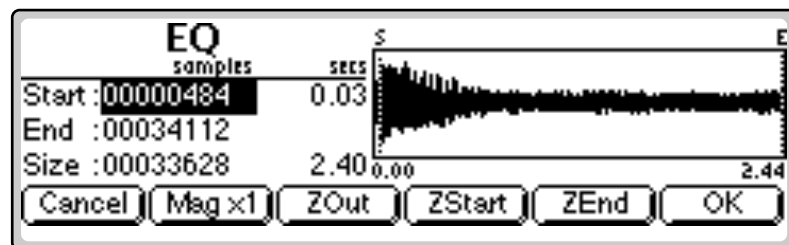

- The Select Section display controls are identical to the controls in Truncate. See Truncate for a full description of the controls.
5. Specify the **Start** and **End** points for the portion of the sample to be EQ'ed using the Data Entry Control, left/right cursor keys, INC/DEC keys or the numeric keypad.
 6. Press **OK** to continue on to the next page of options or **Cancel** to cancel the operation.

6 - Sample Edit
Parametric Equalizer

If you pressed OK, the parametric equalizer parameters are displayed.

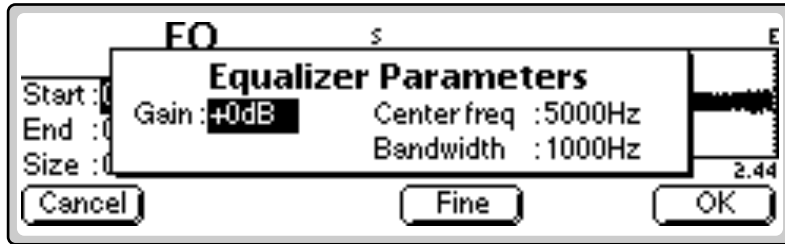

 A standard analog parametric equalizer may be useful in order to locate the frequencies which need EQ. The digital EQ can then be used to actually filter the sample with ultra-low noise and phase linear response.

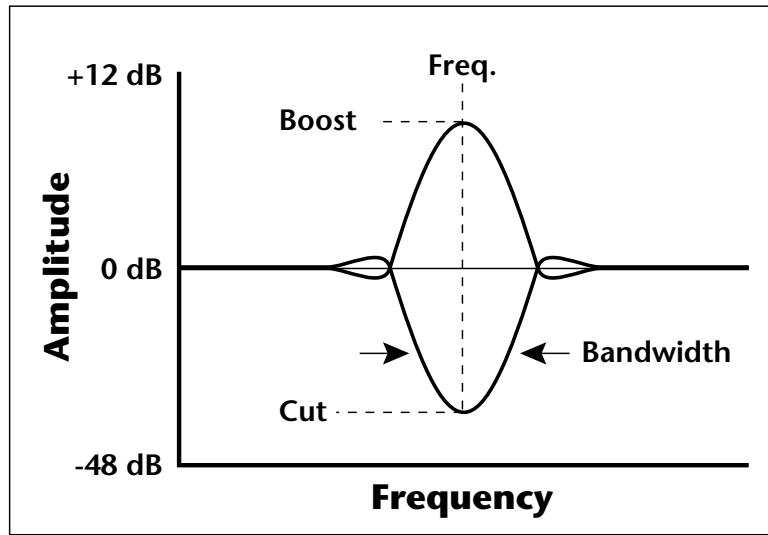

- **Gain:** Controls “how much” boost or cut will be applied to the signal.
 - **Center Frequency:** Selects the center frequency to be boosted or cut.
 - **Bandwidth:** Sets the width of the band to be boosted or cut.
7. Specify the parametric equalizer parameters using the Data Entry Control or the INC/DEC keys.
 - **Coarse/Fine:** Fast forward through the values using Coarse, then switch to Fine for single digit editing.
 8. Press **OK** to process the sample section or **Cancel** to cancel the operation.

FIR (Phase Linear Filter)

The phase linear filter was originally developed on the EIII to separate the attack and sustain portions of piano samples. Ordinary filters cause serious phase distortion at the cutoff point. This FIR filter has much less phase distortion than a typical filter and so is better suited for sample splicing. The phase linear filter acts on the ENTIRE sample, unlike the parametric filter which can filter any portion of the sample. This ensures strict phase-linearity. There are five types of phase linear filters available: **Lowpass**, **Highpass**, **Bandpass**, **Allpass** and **Notch**.

The **Points** parameter determines the Quality or Q of the filter. The larger the Point value, the more the filter behaves like an ideal filter and the steeper the filter slope. The Points parameter is variable from 5 to 99.

The **Frequency** parameter determines the cutoff frequency of the filter and is calibrated in Hertz. When Bandpass or Notch filters are selected, a second frequency field appears to allow you to specify the frequencies on either side of the passband or notch.

The **Allpass** filter is a special purpose filter that is used to add delay to a sample before it is recombined with a filtered sample. Recombining allows you to perform band-splitting or frequency boosting instead of frequency attenuation.

To Filter a Sample:

1. Press the **Sample Edit** key. The LED illuminates and the main sample edit screen appears.
2. **Select the sample** that you want to equalize using the Data Entry Control, INC/DEC keys, or the numeric keypad.
3. Press the **Tools 3** function key (F4). Another row of function keys appears.
4. Press the **FIR** function key (F4). The following screen appears.

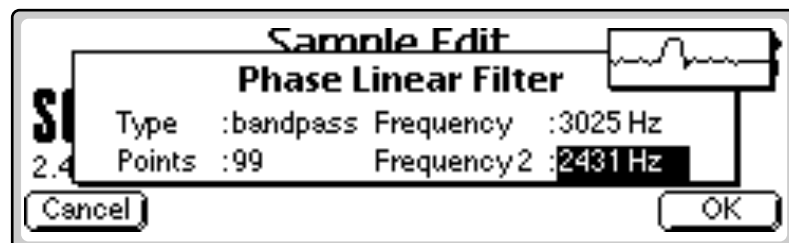

 Holding down the Enter key while turning the Data Entry Control allows "fine tuning" of the value by one number per click.

5. Select the filter **Type**: Lowpass, Highpass, bandpass, Notch or Allpass.
6. Set the filter slope by adjusting the **Points** parameter. The higher the number, the steeper the filter slope.
7. Set the **Frequency** parameter to the desired frequency. If you chose the Bandpass or Notch filters, the **Frequency 2** field will appear, allowing you to set the lower frequency in the range.
8. Press **OK** to filter the sample or **Cancel** to cancel the operation.

6 - Sample Edit
FIR (Phase Linear Filter)

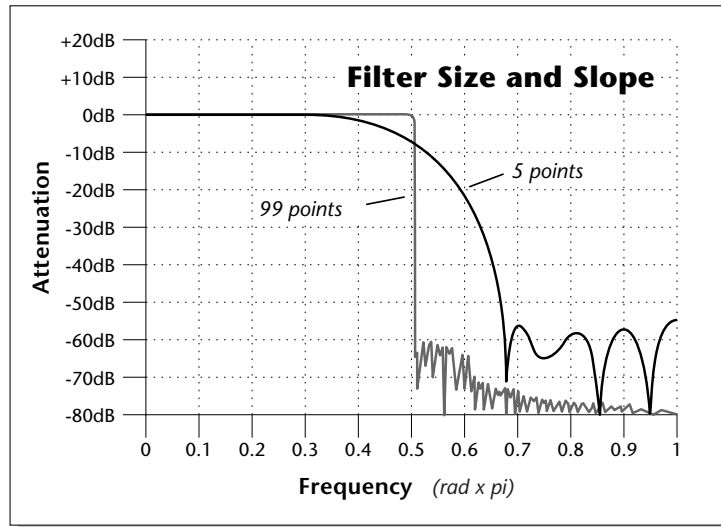

This chart shows the relationship between the filter Points and Slope.

• **Alternate Filter Responses**

Low Shelving Boost - Add Lowpass with original signal.

High Shelving Boost - Add Highpass with original signal.

Band Boost - Add Bandpass with original signal.

The Allpass filter can be used to achieve complex formants, notches or frequency boosts by *copying, filtering* and *adding* the original sample to the filtered version. When adding filtered signals with the FIR, each signal must be processed through the same number of points to preserve phase-linearity. The diagram below shows the incorrect and correct ways to add signals together.

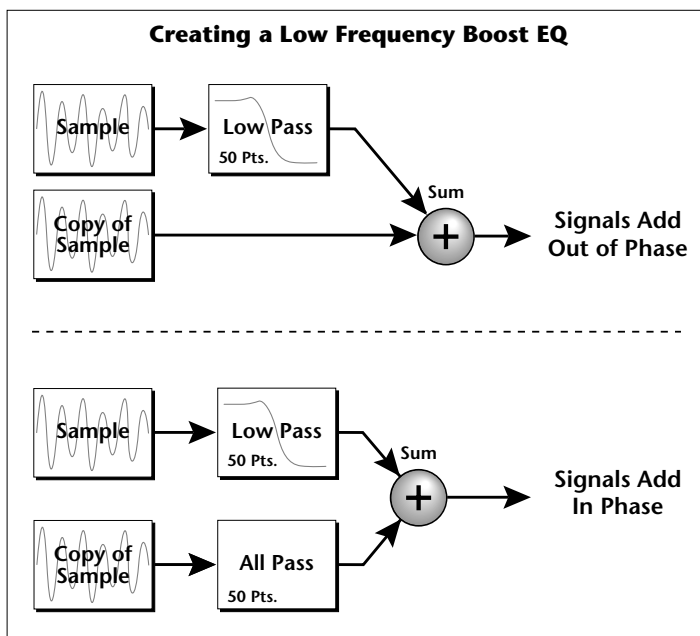

The signal is passed through the Phase-linear filter and recombined with the original signal to create a low frequency boost. Because of the filtering, the two signals are now out of phase. The Allpass filter, set to the same point size, is used to correct the problem.

Aphex Aural Exciter

This process adds brilliance and “cut” to a sample, making it stand out in a mix. This effect is quite effective on vocal samples to which it adds sheen, clarity and presence. The Aphex Aural Exciter® works by generating new high order harmonics related to the source material.

☞ To Add Excitement to a Sample:

1. Press the **Sample Edit** key. The LED illuminates and the main sample edit screen appears.
2. **Select the sample** that you want to aural excite using the Data Entry Control or the INC/DEC keys.
3. Press the **Tools 3** function key (F4). Another row of function keys appears.
4. Press the **AX** function key (F5). The standard Start & End Point selection screen appears.
5. Specify the **Start** and **End** points for the effect
6. Press **OK** to continue or **Cancel** to cancel the operation.

 If the sample is stereo, a pop up dialog box will ask you to select left, right or both sides.

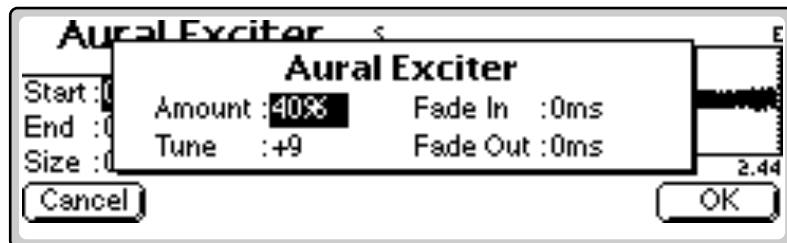

The Aphex Aural Exciter parameters are as follows:

- **Amount:** Sets the intensity of the effect. Lower values (<40%) tend to work best as they keep the effect subtle.
- **Tune:** Sets the frequency range of the effect. Higher numbers emphasize higher frequencies.
- **Fade In:** Sets the amount of time from the start point for the effect to fade in to the programmed amount.
- **Fade Out:** Sets the amount of time before the end point that it will take for the effect amount to fade out to zero.

7. Specify the Exciter parameters using the Data Entry Control or the INC/DEC keys.
8. Press **OK** to process the sample or **Cancel** to cancel the operation.

© The Aphex Aural Exciter has been licensed from Aphex Systems, Ltd. and is protected under U.S. Patent #4150253.

Tools 4



This submodule contains the advanced digital processing tools listed below.

Transform Multiplication: This function merges two sounds together in a unique way which can create many strange and beautiful sonic textures. Frequencies common to the original sounds are accentuated while uncommon frequencies are discarded.

Doppler: This unique function allows you to dramatically move a sound from front to back and side to side in a 3-D space. Several pre-computed paths are available.

Time Compression: This function changes the length of a sample without changing the pitch. This can be very useful for fitting samples to the beat of a song or fitting dialog into a spot. Samples can be compressed or expanded in length from 50% to 200%.

Pitch Change: This function changes the pitch of a sample without changing the time relationships between events. The maximum amount of pitch change is ± 1200 cents (\pm one octave).

Bit Converter: This function allows you to decrease the bit resolution of your samples.

Beat Munger: This amazing feature lets you change the tempo, time signature and add or subtract swing from recorded music.
(Available only on Ultra Emulators.)



Caution: Transform Multiplication can take quite a bit of time with longer samples. Begin your experiments with short samples or even sample attacks as these will give good initial results.



Ideas for using Transform Multiplication:

- Try using the same sound for both samples.
- Splicing silence to the beginnings or ends of short samples can change the spectral characteristics of the result.
- Using speech as one of the sources, it is possible to “speak from within” violins, bassoons, cymbals, etc.

Transform Multiplication

This unique function merges two sounds together so that frequencies common to both sounds are accentuated while uncommon frequencies are discarded (*also called Convolution*). Because of this characteristic, Transform Multiplication tends to work best with sounds that are harmonically rich. Transform Multiplication is a powerful synthesis technique which can produce strange and beautiful timbres. Try it!

Using this function is easy, just pick two sounds and go. The length of the resulting sample will be equal to that of the current sample.

To Transform Multiply Two Samples:

1. Press the **Sample Edit** key. The LED illuminates and the main sample edit screen appears.
2. **Select the first sample** that you want to multiply using the Data Entry Control, INC/DEC keys, or the numeric keypad.
3. Press the **Tools 4** function key (F5). Another row of function keys appears.
4. Press the **XMult** function key (F1). The following screen appears.



5. **Select the second sample** to be multiplied using the Data Entry Control or the INC/DEC keys. The second line of the window will show the sample length and rate of the second sample.
6. Press **OK** to begin processing or **Cancel** to cancel the operation.

Doppler

This function allows you to apply a programmed sound path to a mono sample or the left side of a stereo sample. The result is a stereo sample with pitch shifts and left-right gains adjusted according to the path. The sound can move dramatically forward-back and left-right in a 3-D space in front of the listener. Several interesting programmed paths are available.

To Doppler Shift a Sample:

1. Press the **Sample Edit** key. The LED illuminates and the main sample edit screen appears.
2. **Select the sample** that you want to dopplerize using the Data Entry Control, INC/DEC keys, or the numeric keypad.
3. Press the **Tools 4** function key (F5). Another row of function keys appears.
4. Press the **Doppler** function key (F2). The following screen appears.

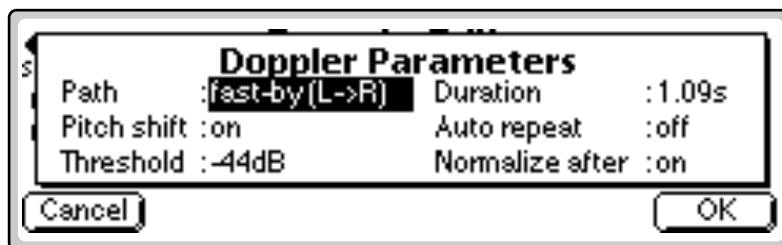

The doppler parameters are as follows:

Path: Sets the course that the sound will travel.

- **Pitch Shift:** (On/Off) When pitch shift is turned Off, the processor functions as an auto-panner.
- **Threshold:** Certain sound paths may take the sound source very far away from the listener, resulting in little or no resulting amplitude. The “Threshold” parameter specifies the maximum amplitude attenuation of the original sample that will ever occur. By setting this parameter appropriately, you can ensure that the resulting sample will produce at least a minimum amplitude output at every point along the path. A setting of 0 dB would prevent any amplitude changes whatsoever. A setting of -96 dB would not prevent the sound from completely fading away at some points.
- **Duration:** The Path Duration allows you to scale the path time so that it runs to completion in a time shorter than the length of the sample. The default value is always the length of the sample. If auto-repeat is Off (see below), the sound will remain at the end of the path until the sample is complete.

- **Auto Repeat:** Auto repeat causes the path to repeat if the end is reached before the sample has completely played. Auto repeat will only occur if path duration is set to a value less than the sample length. The default setting for auto repeat is Off.
 - **Normalize After:** This function (when On) automatically normalizes the sample after the doppler processing has been performed.
5. **Specify the doppler parameters** using the Data Entry Control or the INC/DEC keys.

The Path choices are as follows:

Fast-by (L->R)	Sound moves left to right quickly
Slow-by (L->R)	Sound moves left to right slowly
Far->Near (fast)	Sound moves far away to close quickly
Far->Near (slow)	Sound moves far away to close slowly
Near->Far (fast)	Sound moves close to far away quickly
Near->Far (slow)	Sound moves close to far away slowly
Small Circle	Sound moves in an 8 ft. circle in front
Medium Circle	Sound moves in a 50 ft. circle in front of you
Large Circle	Sound moves in a 120 ft. circle in front of you
Huge Circle	Sound moves in a 250 ft. circle in front of you
Random 1	Sound moves in a random path in front of you
Random 2	Sound moves in a different random path

The computed paths are always initially scaled to the length of the sample, although this time may be changed using the Duration parameter.

6. Press **OK** to process the sample or **Cancel** to cancel the operation.

 Stereo samples maintain phase accuracy when time compressed or expanded.

 If the sample is stereo, a pop up dialog box will ask you to select left, right or both sides.

Time Compression

This function allows you to change the length of a sample without changing the pitch. This is a useful function for fitting samples to the beat of a song or fitting dialog into a spot. Samples can be compressed or expanded in length from 50% to 200% in steps of 1/10th of one percent.

The tempo calculator makes it easy to change the tempo of sampled grooves. Simply set the original tempo to the tempo of the groove, then adjust the ratio until the new tempo matches the tempo you want.

To Compress the Time of a Sample:

1. Press the **Sample Edit** key. The LED illuminates and the main sample edit screen appears.
2. **Select the sample** that you want to process using the Data Entry Control, INC/DEC keys, or the numeric keypad.
3. Press the **Tools 4** function key (F5). Another row of function keys appears.
4. Press the **TimeX** function key (F3). The following screen appears.



5. Enter the desired time compression (or expansion) ratio using the Data Entry Control, INC/DEC keys, or the numeric keypad. The lower line of the display will change to show the resulting length of the compressed or expanded sample. The New Tempo calculation will also update according to the entered Ratio.

Time Compression Ratios: 200% = Double the Length
50% = Halve the Length

6. Select the general type of sample to be processed.

The following table lists the sample type choices.

deep	Predominant deep bass (to 14 Hz)
bass	Predominant bass (to 20 Hz)
mid-1	Average source material
mid-2	Average source material (high-mids)
high	Source material with high frequencies
tight	Maintains time accuracy - Drum loops
broad	Low bass energy but critical highs
broad-smooth	Both high & low freq. - Smooth output
difficult	Inharmonic or broadband material
noisy	Non-pitched - Sound Effects, etc.
tight-smooth	Rhythmic accuracy - Use small ratios
x-smooth	Rhythmic accuracy - Use small ratios

7. Press **OK** to process the sample or **Cancel** to cancel the operation.

Pitch Change

This function is the exact opposite of Time Compression in that it changes the pitch of a sample without changing the time. The maximum amount of pitch change is ± 1200 cents (\pm one octave).

To Change the Pitch of a Sample:

1. Press the **Sample Edit** key. The LED illuminates and the main sample edit screen appears.
2. Select the **sample** you want to process using the Data Entry Control, INC/DEC keys, or the numeric keypad.
3. Press the **Tools 4** function key (F5). Another row of function keys appears.
4. Press the **PitchX** function key (F4). The following screen appears.

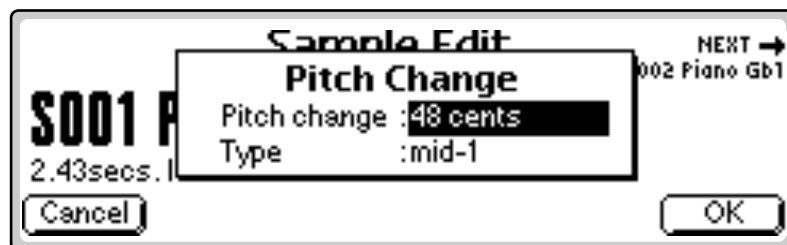

5. Enter the desired pitch change interval in cents using the Data Entry Control, INC/DEC keys, or the numeric keypad.
6. Select the general type of sample to be processed.

6 - Sample Edit Bit Converter



If you are not happy with the results of Pitch Change, simply Undo, then choose another algorithm.

The choices are:

deep	Predominant deep bass (to 14 Hz)
bass	Predominant bass (to 20 Hz)
mid-1	Average source material
mid-2	Average source material (high-mids)
high	Source material with high frequencies
tight	Maintains time accuracy - Drum loops
broad	Low bass energy but critical highs
broad-smooth	Both high & low freq. - Smooth output
difficult	Inharmonic or broadband material
noisy	Non-pitched - Sound Effects, etc.
tight-smooth	Rhythmic accuracy - Use small ratios
x-smooth	Rhythmic accuracy - Use small ratios

7. Press **OK** to process the sample or **Cancel** to cancel the operation.

Bit Converter

For those who want to return to a simpler time when samples were eight bits (or less), we offer the Bit Converter. The Bit Converter takes your pristine 16 bit samples and transforms them into any bit resolution you select. Ever wonder what a 1-bit sample sounds like? Find out with the bit converter. You cannot increase the bit resolution once it's been removed.



Tip #1: You can create silent samples by setting the bit resolution to zero.

Tip #2: The Bit Converter can be used to optimize samples for playback on 8 bit devices.

To Change the Bit Resolution of a Sample:

1. Press the **Sample Edit** key. The LED illuminates and the main sample edit screen appears.
2. **Select the sample** you want to process using the Data Entry Control, INC/DEC keys, or the numeric keypad.
3. Press the **Tools 4** function key (F5). Another row of function keys appears.
4. Press the **BitCnv** function key (F5). The following screen appears.

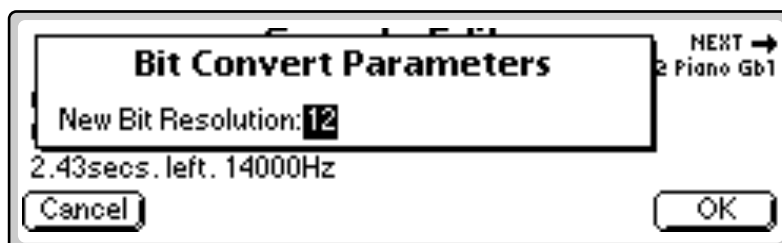

5. Enter the desired bit resolution using the Data Entry Control, INC/DEC keys, or the numeric keypad.
6. Press **OK** to process the sample or **Cancel** to cancel the operation.

 **Note** - Beat Munger is only available on Ultra series Emulators because it requires mucho processor horsepower.

Beat Munger

Beat Munging is a new real-time DSP tool that analyzes your drum loops and phrases, automatically determines the tempo, and then perfectly loops the sample for ultimate groove preservation. Beat Munging also allows you to change the loop's time signature (i.e. from 4/4 to 7/8), tempo, swing factor, and individually manipulate beats within the loop, all in real-time.

Through complex spectral analysis, the Analyzer determines the high points in the energy curve (the beats), locates and remembers the location of transients in the signal, and extracts the tempo (*displayed in the Analysis Results field*). Once the analysis is complete, the main Beat Munger screen is displayed. Pressing **Play** allows you to hear the loop. Adjust the controls and hear the changes in real-time (*it may take a second or two to hear the results after moving a control, depending on the source data or the position of the loop*). When you're satisfied with the settings, press **OK** to process the actual sample data. The sample will be backed-up for UNDO and the newly processed sample will **REPLACE** the source sample. **Back up the original sample first if you want to keep it!**

To Beat Munge:

1. Press the **Sample Edit** key. The LED illuminates and the main sample edit screen appears.
2. **Select the sample** you want to process using the Data Entry Control, INC/DEC keys, or the numeric keypad.
3. Press the **Tools 4** function key (F5). Another row of function keys appears.
4. Press the **BeatM** function key (F6). A spectral analysis will be performed to find the tempo and beats. The following screen appears.



- If you try to process a sample without beats, a pop-up window informs you that the "Sample has no groove!"
5. Press **Play** to hear your looped groove.
 6. Adjust the parameters using the Data Entry Control, INC/DEC keys, or the numeric keypad and hear changes in real-time.
 7. Press **OK** to process the sample or **Cancel** to cancel the operation.

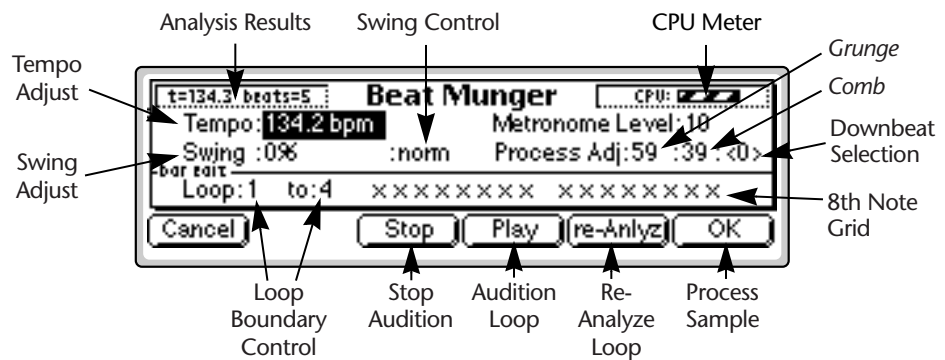

Beat Munger Controls

- **Analysis Results:** This field displays the analyzed tempo and number of beats in the sample. The sample may contain any number of beats and this number will also be displayed in the Loop Controls field.
- **Tempo Adjust:** Adjusts the Tempo of the loop (*you knew that*) without altering the pitch. The Tempo field defaults to the tempo determined from the analysis.
- **Swing Adjust & Control:** Swing can be modified in both a positive and negative (anti-swing) direction. Negative swing can actually remove swing from a groove.

With Swing set to “Norm” and “0%”, each quarter note is weighted so that the first eighth note takes up 50% of the quarter note and the second eighth note takes up the other 50%. When the swing factor is changed to a positive amount, the first eighth note takes up more of the time and the second eighth note gets the rest. Negative swing lengthens the time spent on the second eighth note

There are four different swing controls.

- Fast** Swings within an eighth note
- Norm** Swings within a quarter note
- Slow** Swings within a half note

- **Loop Boundary Control:** These controls allow you to redefine the start and end points of the loop. For example, you could remove the first beat of a loop or the last bar of a four bar loop. The default setting of this field is determined by the length of the loop.
- **Downbeat Selection:** Sometimes Beat Munger makes a mistake when choosing the proper downbeat and may choose an upbeat instead. This control allows you to correct the mistake. Depending on the source material, several choices may be provided. Use this feature in conjunction with the metronome. You can also use this control to deliberately place the accent on other beats.

 Stereo samples use more CPU resources than mono samples in real-time audition mode.

• **Process Adjust Controls:**

Grunge controls the splice crossfade length. This control can make the sound rough, smooth, or “flangy”. Smaller values produce shorter crossfades. Longer crossfades use more CPU resources.

Comb adjusts the distance between splices. This control can be used to keep the groove rhythmically tight, produce comb-filter effects, or create echo-type effects (*depending on the source material*). Low values can keep the sound from becoming too “fluttery”, especially when shifting the tempo down, but consume more CPU resources.

- **8th Note Grid:** The 8th note grid is a representation of two bars of 8th notes. Individual 8th notes can be turned Off or On. If the loop is longer than 2 measures, the 2-bar grid settings will also be applied to the following measures. The diagram below shows how the 8th note grid corresponds to 8th notes and quarter notes.

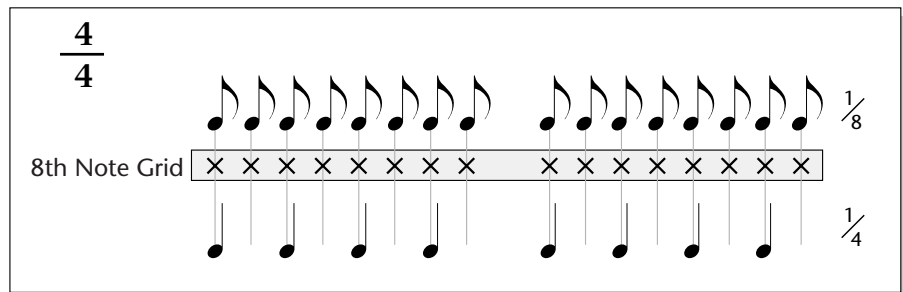

The time signature can be altered by removing notes from the loop. The diagram below shows a 2-bar loop in 4/4 time being changed into 7/8 time.

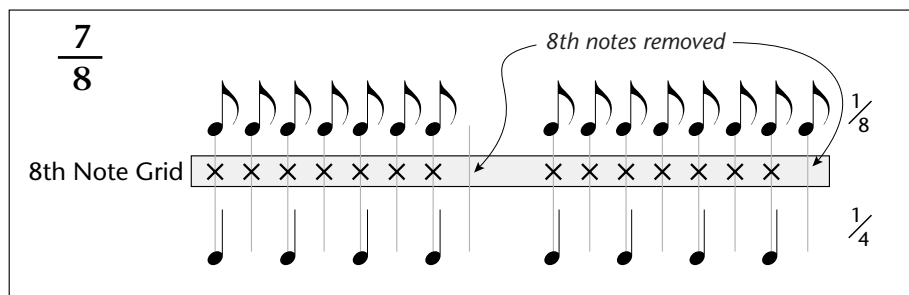

 **Note:** Final rendering (i.e. pressing **OK** to actually change the sample data) will always be processed correctly even if real-time playback is choppy.

- **Metronome Level:** Adjusts the volume level of the metronome. The metronome is useful in determining the proper downbeats.
- **CPU Meter:** The CPU meter shows the amount of CPU power being used while auditioning in real-time. Extreme settings of the controls with stereo samples may tax the CPU to the point where the audio quality is affected. The CPU meter is a barberpole which moves at a constant rate when everything is running normally. If you see the barberpole stutter or freeze, you may want to select more normal control settings.

6 - Sample Edit Beat Munger

 Sometimes the Munger misses the last beat of a looped, 1 bar groove. To correct this problem, Copy the loop and Paste to the end of itself. Truncate the loop with Beat Munger to get a perfect 1 bar loop.

- **Play Button:** Starts real-time loop audition.
- **Stop Button:** Stops real-time loop audition.
- **Re-Analyze Button:** Sometimes the analyzer will lock onto a harmonic of the tempo, or some other polyrhythmic element in the groove, and give the wrong answer for the tempo analysis. The Re-Analyze button allows you to enter your own estimate of the true tempo. Beat Munger will use your tempo data to resynthesize the groove.
- **OK Button:** Once you are happy with the settings, press OK to actually process (and replace) the sample. The metronome will not be heard in the processed sample and the sample will always be rendered correctly even if the real-time audition was of poor quality. The sample will be set to loop its entire length. UNDO is available to restore the original sample if you're not happy with the result.

“Signal Appears to be Cropped” message

Congratulations! You've already trimmed your sample groove to loop perfectly. This screen is merely informing you that the sample is perfectly sized to loop.

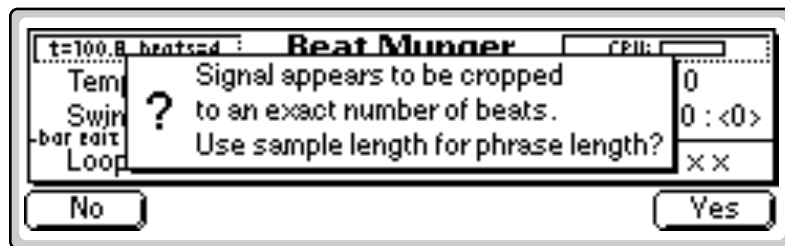

- Press Yes if you want to use the sample length for the phrase length.
- Press No if you want Beat Munger to determine a tempo.

Undo

Have you ever wanted a time machine so that you could go back and undo a mistake? This function may be the next best thing. Whenever you

perform a sample edit function, the original version of the sample will be backed up if “Undo/Redo” is enabled (Master, Miscellaneous). The original sample is placed on the clipboard and can be instantly restored by pressing Undo.

 **To Restore a Sample to its Original State**

1. Press the **Sample Edit** key. The LED illuminates and the main sample edit screen appears.
2. Press the **UNDO!** function key (F6). The original sample will be restored and the processed sample will be stored in the clipboard.

 **To Compare a Processed Sample with the Original Sample:**

1. Press the **Sample Edit** key. The LED illuminates and the main sample edit screen appears.
2. Press the **UNDO!** function key (F6). The original sample will be restored and the processed sample will be stored in the clipboard.
3. Press the **REDO!** function key (F6) again. The processed sample will be restored and the original sample will be stored in the clipboard. You can continue switching back and forth until you decide which sample you want to keep.

6 - Sample Edit

Preset Manage

7

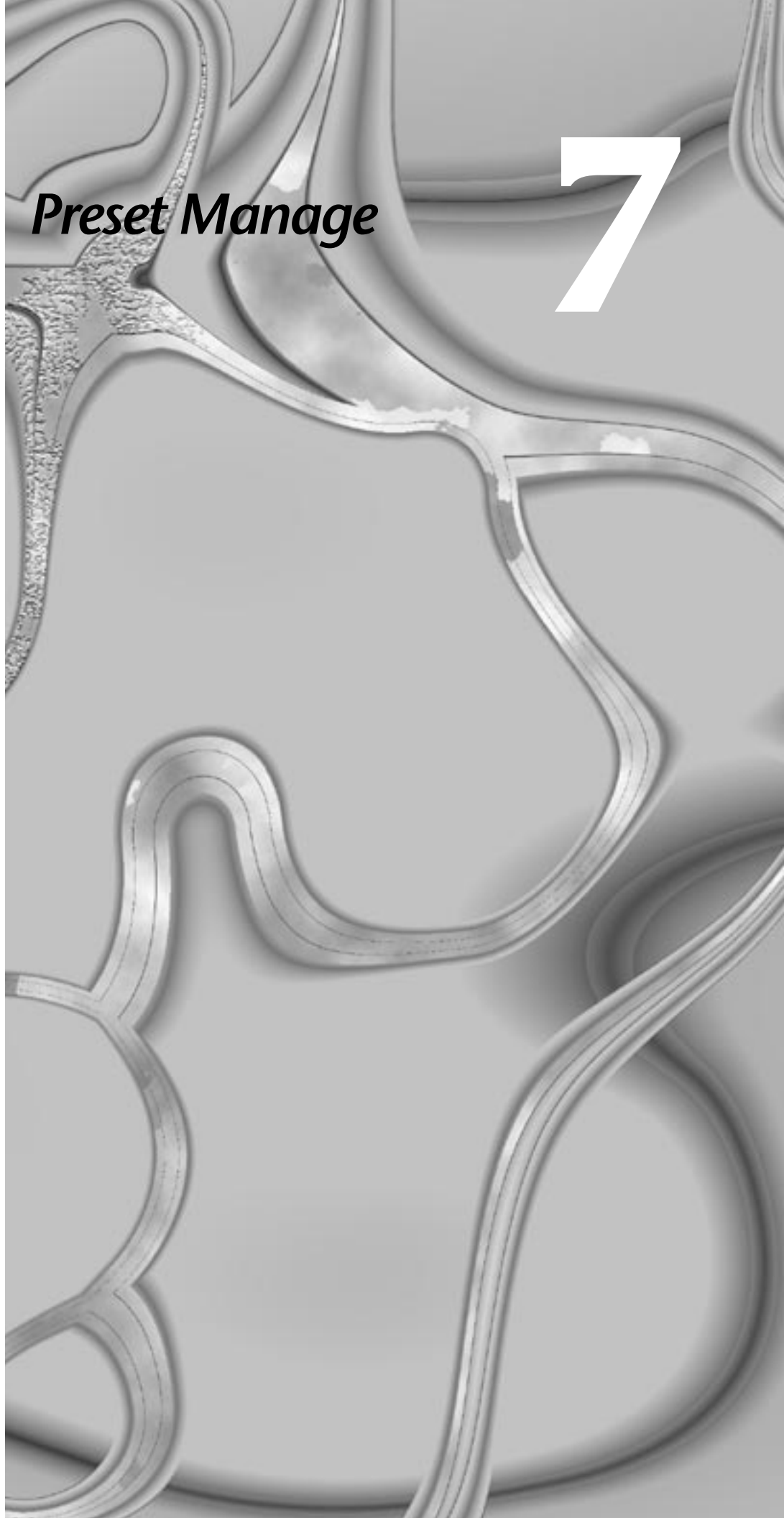

7 - Preset Manage

Preset Manage



This module handles the preset “housekeeping” functions such as: creating, erasing, copying, exporting naming presets. You can also find out how much memory a preset uses, to which output it is assigned, and if it is linked to another preset.

The Preset Manage menu contains six main sub menus:

Utils. Contains two utilities - Erase Sample and MIDI Preset Dump.

Name. Allows you to name or rename a preset.

New. Creates a new preset location.

Copy. Copies a preset to another location.

Export. Allows you to export a preset into another bank.

Info. Displays information on the selected preset.

Utilities

Erase Preset

This function allows you to erase any preset in the bank.

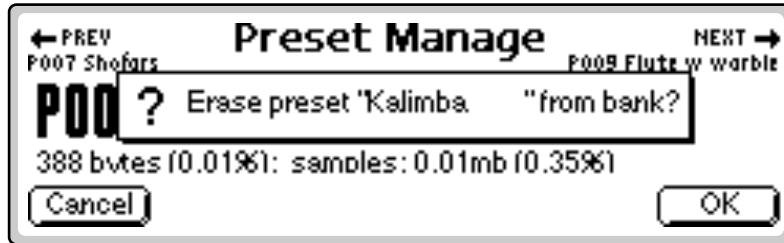

To Erase a Preset:

1. Press the **Preset Manage** key. The LED illuminates and the main screen appears.
2. **Select the preset** to be erased using the Data Entry Control, INC/DEC keys, or the numeric keypad.
3. Press the **Utils** function key. Another row of function keys appears.
4. Press the **Erase...** function key. A pop-up dialog box (shown above) appears asking you if you want to erase the preset.
5. Press **OK** to erase the preset or **Cancel** to cancel the operation.

Dump Preset

Transmits the MIDI SysEx data for the current preset. Sample data is not transmitted, only the preset parameters. The preset data is sent out in small packets to avoid clogging the receiving machine. If MIDI Out is connected to MIDI In of another E4 compatible machine, the transmitted preset data will replace the same numbered preset on the receiving unit.



To Dump a Preset:

1. Press the **Preset Manage** key. The LED illuminates and the main screen appears.
2. **Select the preset** to be dumped using the Data Entry Control, INC/DEC keys, or the numeric keypad.
3. Press the **Utils** function key. Another row of function keys appears.
4. Press the **Dump...** function key (F2). Transmission of the preset data begins immediately.

 See the E-MU Systems web site for the EOS SysEx specification.

 Preset data is backwards compatible with all E4 models.

Name Preset

This function allows you to name or rename any preset in the bank.

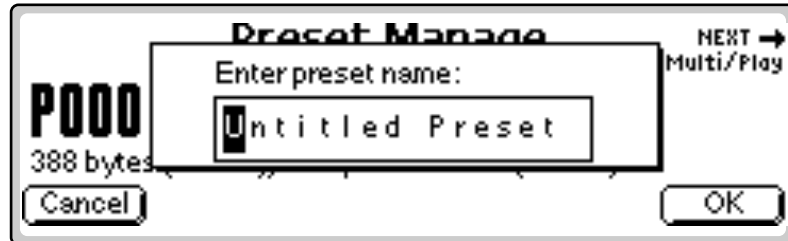

To Name a Preset:

1. Press the **Preset Manage** key. The LED illuminates and the main screen appears.
2. **Select the preset** to be named using the Data Entry Control, INC/DEC keys, or the numeric keypad.
3. Press the **Name** function key (F2). A pop-up dialog box (shown above) appears asking you to enter the new preset name.
4. **Name the preset.** Letters can be selected using the numeric keypad, Data Entry Control, INC/DEC keys and cursor keys, or using an ASCII keyboard.
5. Press **OK** to confirm the new name or **Cancel** to cancel the operation.

New Preset

This function creates a home for your great samples.



To Create a New Preset:

1. Press the **Preset Manage** key. The LED illuminates and the main screen appears.
2. Press the **New...** function key (F3). A pop-up dialog box (shown above) appears asking you to select the destination preset location.

3. **Select the destination preset location** using the numeric keypad, Data Entry Control, INC/DEC keys or using an ASCII keyboard.
4. Press **OK** to confirm the new preset location or **Cancel** to cancel the operation.

Copy Preset

Presets can be copied to other preset numbers within the bank.



To Copy a Preset:

1. Press the **Preset Manage** key. The LED illuminates and the main screen appears.
2. Press the **Copy...** function key (F4). A pop-up dialog box (shown above) appears asking you to select the destination preset location.
3. **Select the destination preset location** using the Data Entry Control, INC/DEC keys or the numeric keypad.
4. Press **OK** to copy the preset or **Cancel** to cancel the operation.

 After exporting, a preset, it can be loaded (Merged) with another bank.

Export Preset

This function allows you to export a preset to another bank. Suppose you were experimenting and modified a preset using the preset edit module. You might want to keep the modified preset, but if you save the bank, the original preset will be lost. Using this function, you can export the modified preset and its samples to a new bank and have both!



To Export a Preset:

1. Press the **Preset Manage** key. The LED illuminates and the main screen appears.
2. **Select the preset** to be exported using the Data Entry Control, INC/DEC keys, or the numeric keypad.
3. Press the **Export** function key (F5). The screen shown above appears.
4. **Select the destination drive, folder and bank** using the cursor keys and Data Entry Control. You cannot write into an existing bank without erasing it. Usually you will choose an empty bank.
5. Press **OK** to export the preset or **Cancel** to cancel the operation.

Get Info

This function displays the preset's size in bytes, lists the number of samples used and lists the amount of remaining memory. It also tells you if the preset is linked to another and to which output it is assigned.



To Get Information about a Preset:

1. Press the **Preset Manage** key. The LED illuminates and the main screen appears.
2. **Select the desired preset** using the Data Entry Control, INC/DEC keys, or the numeric keypad.
3. Press the **Info...** function key (F6). A pop-up window (shown above) appears with information about the sample.
4. Press **OK** to return to the Preset Manage screen.

Preset Edit

8

8 - Preset Edit

Synthesizer Basics

This chapter explains how preset sounds are constructed. It also contains important background information on the various programming aspects of the instrument.

If you are new to synthesizers and electronic music, you may need more background information than this manual provides. There are many books dedicated to synthesizer basics and MIDI available through your local music dealer. Magazines such as *Keyboard* and *Electronic Musician*, which are available at most newsstands, contain current information on the subject, as well as valuable programming tips.

Your initial involvement with the Emulator will most likely consist of using the existing presets and selecting MIDI channels. While the factory banks and presets are very good, there are probably some things you would like to change, perhaps the LFO speed, the filter brightness, or the attack time. You may also want to make your own custom presets using complex modulation routings.

Editing Presets

It's easy to create new presets by using the Preset Edit menu to modify existing presets. This is really the best way of getting acquainted with the Emulator. If you don't like the results, simply reload the preset and you'll be back to the original sound. Changes are not made permanent until you SAVE a bank. Therefore, you can experiment all you want with presets, voices and samples without worrying about losing a sound.

We encourage you to actually try out the different functions as you read about them. Hearing what a control actually does will remove a lot of the mystery associated with it.

The Emulator has an extensive modulation implementation using two multi-wave LFO's (Low Frequency Oscillators), three envelope generators, and the ability to respond to multiple MIDI performance controllers. You can simultaneously route any combination of these control sources to multiple destinations.

Modulation

Modulation means to dynamically change a parameter, whether it be the volume (amplitude modulation), the pitch (frequency modulation), or whatever. Turning the volume control on your home stereo rapidly back and forth would be an example of amplitude modulation. To modulate something we need a modulation source and a modulation destination. The source is your hand turning the knob, and the destination is the volume control. If we had a device that would automatically turn the volume control, we would also call that device a modulation source.

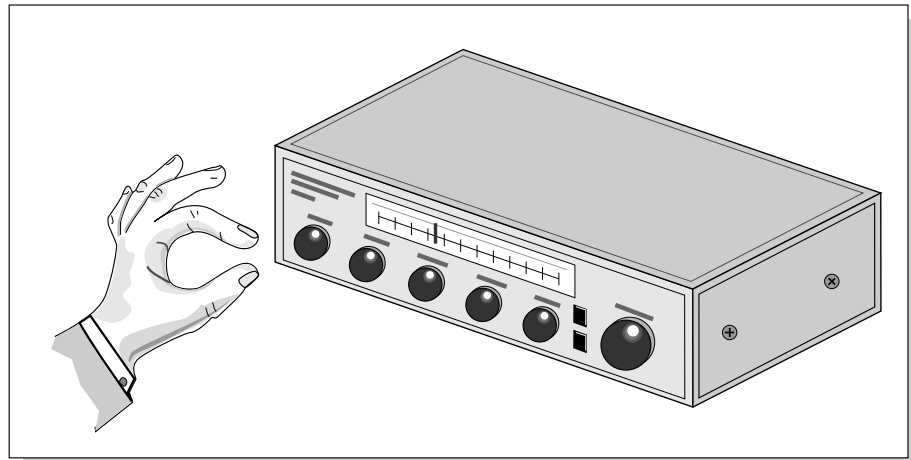

Turning the volume control back and forth on your home stereo is an example of Amplitude Modulation.

The Emulator is designed so that for each of the variable parameters, such as the volume, there is an initial setting which can be changed by a modulation source. Therefore in the case of volume, we have an initial volume and we can change or modulate that volume with a modulation source. Positive modulation *Adds* to the initial amount. Negative modulation *Subtracts* from the initial amount.

Modulation Sources

The main modulation sources are Envelope Generators, Performance Controllers and Low Frequency Oscillators. In the previous example, an envelope generator could be routed to automatically turn the volume control as programmed by the envelope, or, a low frequency oscillator could be routed to turn the volume control up and down in a repeating fashion. The main mod sources are listed below.

Keyboard Key

Which key is pressed.

Key Velocity

How fast the key is pressed.

Release Velocity

How fast the key is released.

Gate

High if the key is pressed, low when the key is released.

Key Glide

A smoothly changing control source based on the Glide Rate and the interval between the last two notes played.

Pitch and Mod Wheels

Synthesizer pitch bend and modulation wheels.

Keyboard Pressure (mono aftertouch)

Key Pressure applied after the key is initially pressed.

Pedal

A continuously variable pedal controller.

Miscellaneous Controllers A -H

Any type of MIDI continuous controller data.

Low Frequency Oscillators (2 per voice)

Generate repeating waves.

Envelope Generators (3 per voice)

Generate a programmable “contour” which changes over time when a key is pressed.

Noise & Random Generators

Generate spectrums of noise and random signals.

Thumb Button and Footswitches

Change a parameter when the switch is pressed.

Modulation Cords

You use a Cord to connect a modulation Source to a Destination.
(Patchcord – a holdover from the days when modules of an analog synthesizer were connected together with physical cords. Nowadays, we still need a way to connect modules together, but the cords are in software.)

You can connect the modulation sources in almost any possible way to the modulation destinations. You can even modulate other modulators. Each cord also has an amount parameter which determines “how much” modulation is applied to the destination. The modulation amount can be positive or negative and will either add or subtract from the initial value.

To use a modulation cord, you must connect a modulation Source to a modulation Destination. Think of it as if you are connecting an actual cord. You must connect both ends of the cord for the cord to work. There are 24 general purpose cords per voice.

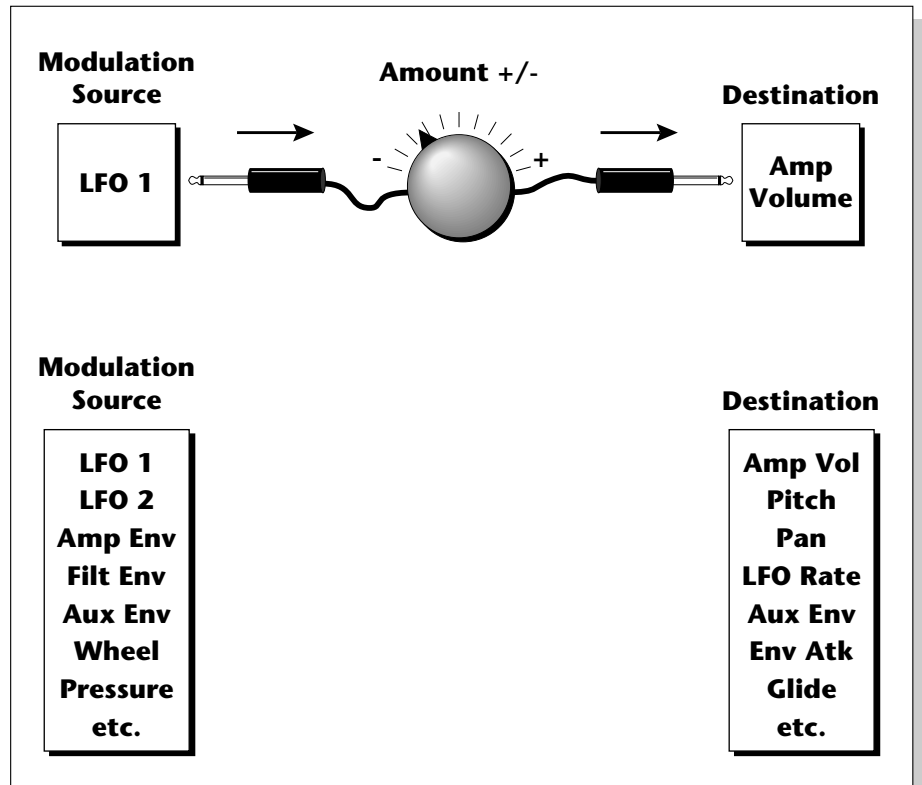

Envelope Generators

An envelope can be described as a “contour” which can be used to shape the sound in some way over time. There are three envelope generators per voice and all of them are the rate/level type.

 The EOS envelope generators are just like standard ADSR's, except that they have two segments for each stage.

- To create a standard ADSR curve, set the “2” levels the same as the “1” levels and set all the “2” rates to 0.

This is how the rate/level envelopes work: When a key is pressed, envelope starts from zero and moves toward the Attack 1 Level at the Attack 1 Rate. As soon as it reaches this first stage, it immediately begins the Attack 2 phase and moves toward the Attack 2 level at the Attack 2 rate. As long as the key is still held, the envelope continues on through the Decay 1 and Decay 2 stages. If the key is still held when the envelope reaches the end of Decay 2, it simply stops there waiting for you to release the key. When you release the key, the envelope continues through its Release 1 and Release 2 stages, stopping at the end of the Release 2 stage. The rate/level envelopes give maximum flexibility to program both complex and simple envelopes.

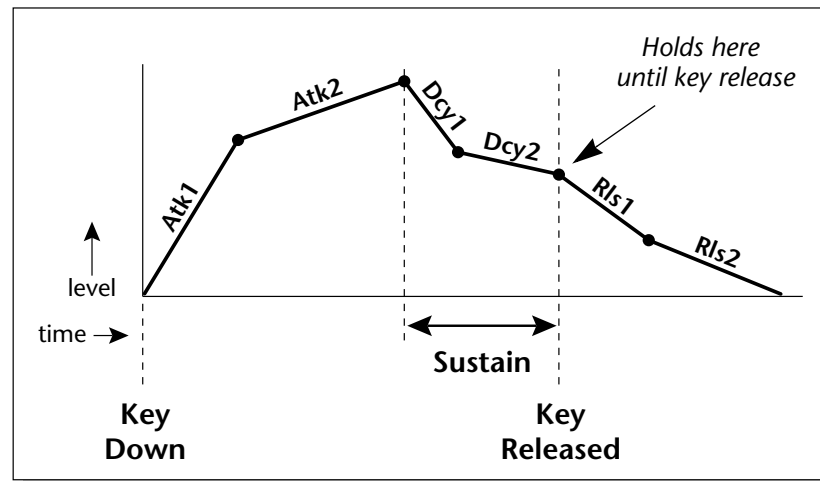

The Amplifier Envelope generator controls the volume of the voice over time and has 6 stages: Attack 1, Attack 2, Decay 1, Decay 2, Release 1 and Release 2. The Filter Envelope generator controls the filter morph and also has 6 stages. Unlike the amplifier envelope, however, the filter envelope has the ability to go negative as well as positive. There is also an Auxiliary Envelope generator which is a general purpose envelope. The auxiliary envelope is identical to the filter envelope and can go negative as well as positive. The time of each stage can be adjusted to create myriad envelope shapes, which in turn shape the sound over time.

 By routing the Auxiliary Envelope to control the pitch (Cords) you can easily hear the shape of the envelopes you are creating.

- The way the volume of a sound changes over time determines how we perceive that sound. For example, a bell struck with a hammer is instantly at full volume, then slowly dies away. A bowed violin sound fades in more slowly and dies away slowly. Using the Amplifier Envelope, you can simulate different types of instrument volume envelopes by programming them appropriately.

8 - Preset Edit

Low Frequency Oscillators (LFOs)

LFO Tricks & Tips:

- The Random LFO wave is truly random and is different for each voice and layer.
- The Pattern (Pat) waveforms will sound the same on different layers and voices.
- Sine + Noise is very useful for simulating trumpet and flute vibrato.

★ When routing Hemi-quaver to Pitch:

- +38 = major scale
- 38 = phrygian scale
- +76 = whole tone scale
- (+38) + (+76) = diminished (two cords)
- odd amount = S+H sound

Note: References to musical intervals in the pattern LFO shapes are with the LFO routed to pitch and a PatchCord amount of +38.



Try combining the Pattern LFOs, or controlling the amount of one with another, or combining them with the clock divisors.

Low Frequency Oscillators (LFOs)

A Low Frequency Oscillator or LFO is simply a wave which repeats at a slow rate. The Emulator has two multi-wave LFOs for each channel. The LFO waveforms are shown in the following illustration.

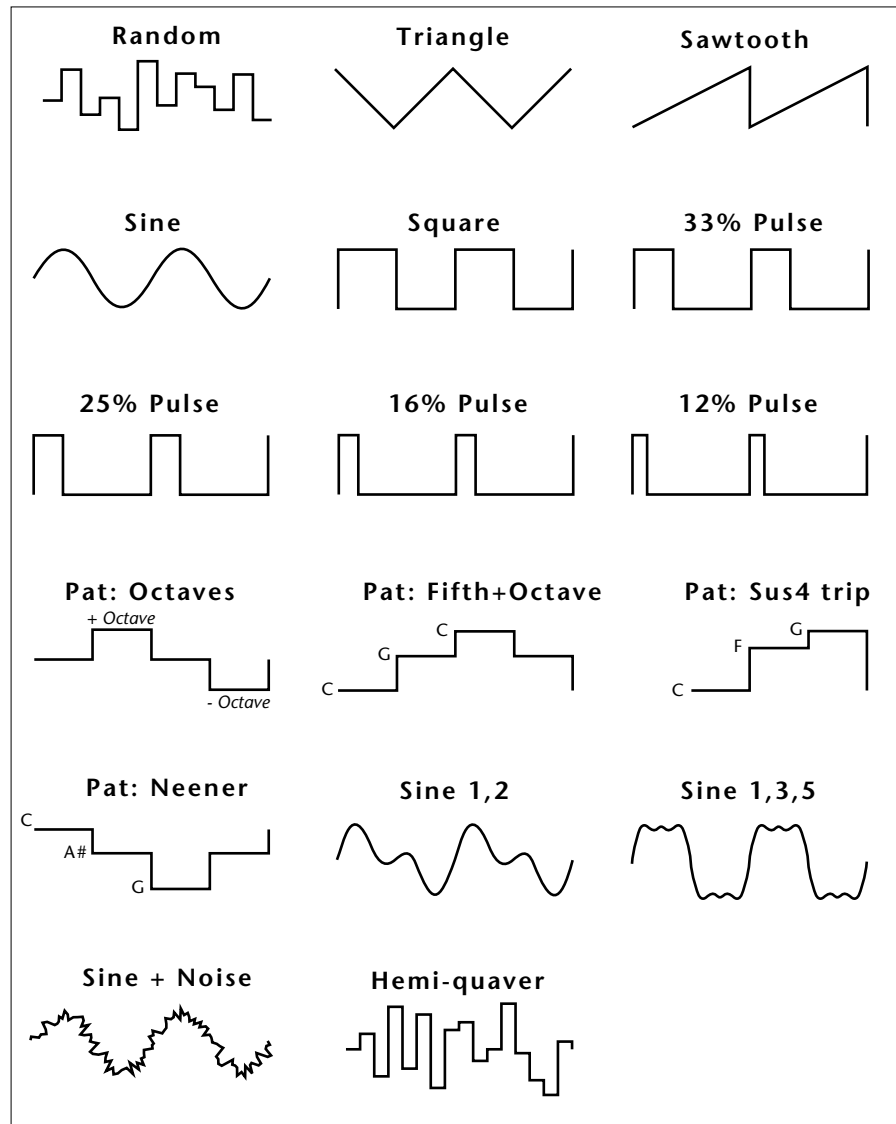

By examining the diagram of the LFO waveforms, you can see how the LFO will affect a modulation destination. Suppose we are modulating the pitch of an instrument. The sine wave looks smooth, and will smoothly change the pitch. The square wave changes abruptly, and will abruptly change the pitch from one pitch to another. The sawtooth wave smoothly decreases, then abruptly changes back up. The sound's pitch will follow the same course. Controlling the pitch of an instrument is an easy way to hear the effects of the LFO waves.

Like the Auxiliary Envelope, the LFOs can be routed to control any realtime functions such as Pitch, Filter, Panning, or Volume. A common use for the LFO is to control the pitch of the sound (LFO -> Pitch). This effect is called vibrato and is an important performance parameter. Many presets use this routing with the modulation wheel controlling “how much” LFO modulation is applied. Another common effect, Tremolo, is created by controlling the volume of a sound with the LFO (LFO -> Volume).

Another use for the LFOs might be to add a slight bit of animation to the sound by routing the LFO to control the filter. In this example, the LFO amount would be set low, for a subtle effect.

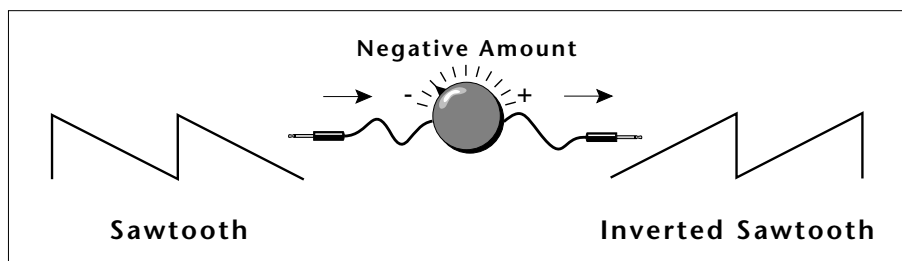

When the amount of an LFO is a negative value, the LFO shape will be inverted. For example, inverting the sawtooth wave produces a wave that smoothly increases, then instantly resets down.

Random Sources

Random modulation sources can be used when you want the timbre of the sound to be “animated” in a random or non-consistent manner.

- **Key Random 1 & 2** generate different random values for each voice which are selected at key-on time and do not change during the note.
- The **White & Pink Noise** Generators produce varying random values. Both white and pink noise sources are low frequency noise designed for control purposes. Either noise source can be filtered even more by passing it through a lag processor.
- The **Crossfade Random** function generates the same random value for all voices in a preset. This source is designed to be used for crossfading voices, although you may find other uses.

 For more info on the *Crossfade Random* function see *Voices - Realtime Window* in this chapter.

Clock Modulation

The Sequencer/Arpeggiator clock can also be used as a modulation source. It can be used to trigger the Filter or Auxiliary envelope generators, trigger Sample Start, synchronize the LFOs, or used directly as a square wave modulation source. Envelopes are triggered on the positive going edge of the clock. LFOs are triggered on the negative going edge.

The Clock source is available in six divisions (double whole note, whole note, half note, quarter note, eighth note, sixteenth note). The different rates can be used separately or in conjunction to create complex “synchro-sonic” rhythm patterns.

Using MIDI clocks, Sequencer/Arpeggiator clock can also be synchronized with an external MIDI device such as a drum machine or sequencer.

Clocks are routed exactly like the other modulations sources using the Cords. The Cord Amount **MUST** be positive (+) for the clock to pass. By modulating the Cord Amount, the divided clocks can be routed around using realtime controllers or other modulation sources.

Syncing an LFO to the Clock

When an LFO is triggered by a clock, the LFO wave resets to zero every time the clock wave goes low. To sync an LFO to the clock, patch a clock divisor to the LFO Trigger (Trg) in the Cords screen.

If the LFO rate is close to the clock rate, **the LFO will synchronize with the clock**. If the two rates are far apart, the waveform of the LFO will be mildly or radically altered (as shown below).

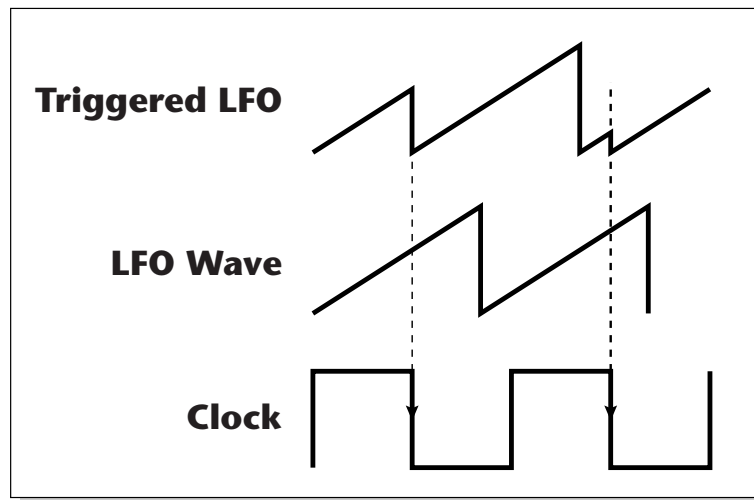

LFO Trigger causes the LFO to reset each time the clock waveform goes low.

The possibilities of clock modulation and retrigger are numerous and varied. A repeating six segment curve of any shape can be created by triggering the Filter or Auxiliary Envelope generators with the clock.

A few other possibilities are listed below.

- Turn different voice layers on and off using different clock divisors.
- Create a global triangle LFO by routing the Clock through a Lag Processor.
- Switch between Auxiliary and Filter Envelope retriggering using a slider, footswitch or the Thumbby button.
- Retrigger LFOs or Envelopes using noise or other LFOs to create random or semi random effects.
- Modulating the rate of triggered LFOs will alter the LFO waveform.
- Route multiple clocks with different divisors to the same destination (such as pitch) to create complex patterns. (Hint: Adjust the Cord Amounts.)

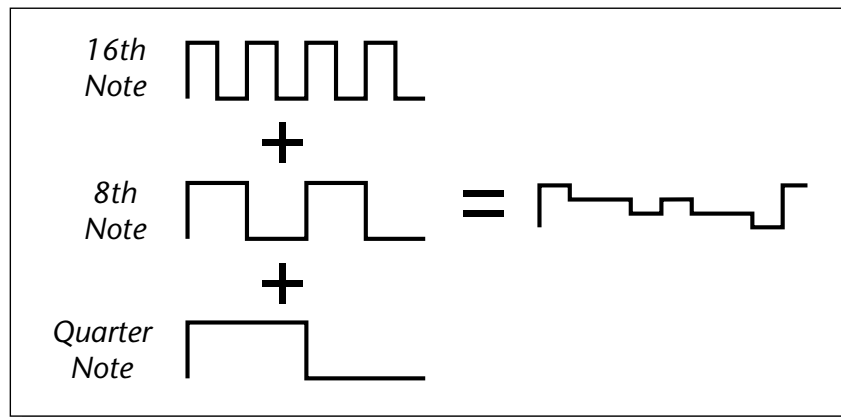
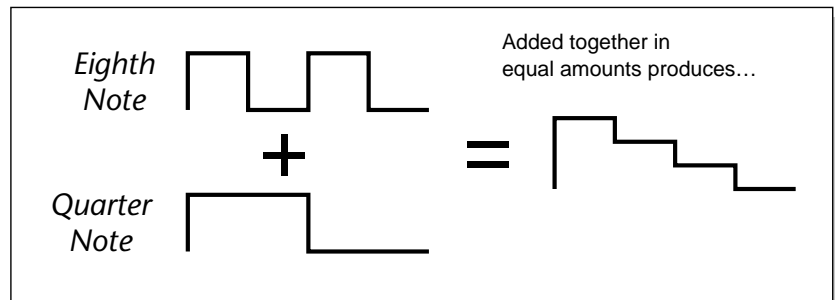

8 - Preset Edit
Modulation Destinations

Modulation Sources

- Off
- Crossfade Random
- Key (+, ~), Velocity (+, ~, <)
- Release Velocity, Gate
- Pitch Wheel, Mod Wheel
- Pressure, Pedal
- MIDI A-H, Foot Switch 1 & 2
- Flip-Flop Foot Switch 1 & 2
- MIDI Volume (Contr. 7)
- MIDI Pan (Contr. 10)
- Key Glide
- Volume Envelope (+, ~, <)
- Filter Envelope (+, ~, <)
- Aux. Envelope (+, ~, <)
- LFO 1 & 2 (+, ~)
- White Noise, Pink Noise
- kRandom 1 & 2,
- Lag 0 in (summing amp out)
- Lag 1 in (summing amp out)
- Lag Processor 0 & 1
- Clock Divisors
- DC Offset, Summing Amp Switch, Absolute Value
- Diode, Flip-Flop, Quantizer
- Gain 4x

Modulation Destinations

- Off
- Key Sustain, Fine Pitch, Pitch Glide, Chorus Amt
- ~Chorus Position ITD
- ~Sample Start, Sample Loop
- Sample Retrigger
- Filter Freq., ~Filter Resonance
- Amplifier Volume, Amp Pan
- Amplifier Crossfade
- Volume Envelope Rates (all)
- Vol. Env. Atk, Dcy, Release
- Filter Envelope Rates (all)
- Filt. Env. Atk, Dcy, Release
- Filter Envelope Trigger
- Aux. Envelope Rates (all)
- Aux. Env. Atk, Dcy, Release
- Aux. Envelope Trigger
- LFO 1 & 2 Rates
- LFO 1 & 2 Trigger
- Lag Processor In 0 & 1
- Summing Amp, Switch
- Absolute Value
- Diode, Flip-Flop, Quantizer
- Gain 4x, Cord 0-23 Amount

Modulation Destinations

The Cords section of the Preset Edit module is where you connect sources to destinations. Each cord has an amount control associated with it to control how much modulation is applied.

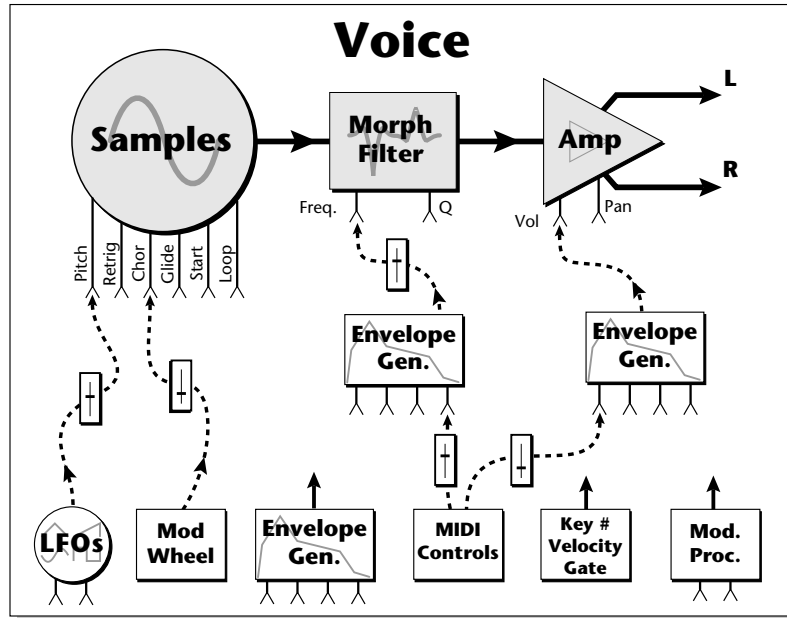

The Cords screen and the diagram above show how modulation sources are connected to destinations. The modulation sources can control any of the destinations in the voice.

- Note-on modulation sources, such as key, velocity and gate output a single value at note-on time. Realtime modulation sources such as LFOs, envelope generators and modulation wheels can be varied continuously.

The possible modulation routings are completely flexible as shown in the diagram above. Multiple sources can control the same destination, or a single source can control multiple destinations.

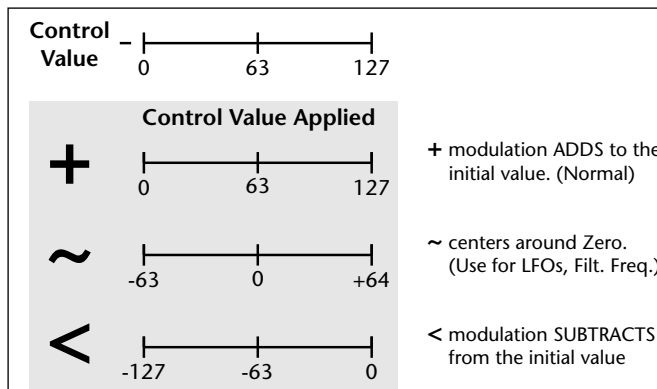

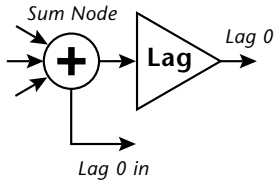

Modulation Processors

Modulation processors are devices which can modify modulation sources such as LFOs and envelope generators before they are applied to a destination. The modulation processors allow you to create patches and do tricks which would not be possible otherwise. The following modulation processors are currently implemented:



 The Lag Processors can also be used as 2 additional summing amps. Lag0in and Lag1in are available as modulation sources which are the sum of any cords connected to the Lag in destination. The summing amp is before the lag processor as shown above.

 A digital "1" is equal to the patch cord amount.

 The Flip-Flop Footswitch will stay On until it is pressed again. Then it will toggle Off.

Switch	Outputs a digital "1" when the input is greater than "0".
Summing Amp	Allows you to mix several modulation signals together before applying them to a destination. This saves cords when the output is to be routed to multiple destinations.
Lag Processors	Slows down rapid changes in the input signal. The output "lags" behind the input at a programmed rate (set in the LFO 2 screen).
Absolute Value	This function inverts negative values presented to it and leaves positive values alone. This device outputs only positive values.
Diode	This function only allows positive values to pass and blocks negative values.
Flip-Flop	The output of this processor alternates between a digital "1" and digital "0" each time the input goes positive from zero or a negative value. If an LFO wave were input, the output would be a square wave of half the input frequency.
Quantizer	With the input cord set to 100%, the output value is limited to 16 discrete values (If the input = sawtooth wave, then the output = staircase). The value of the input cord controls the number of steps. The value of the output cord controls the size of the steps.
4x Gain	This processor multiplies the input value by 4 to amplify modulation sources.

Modulation Processors

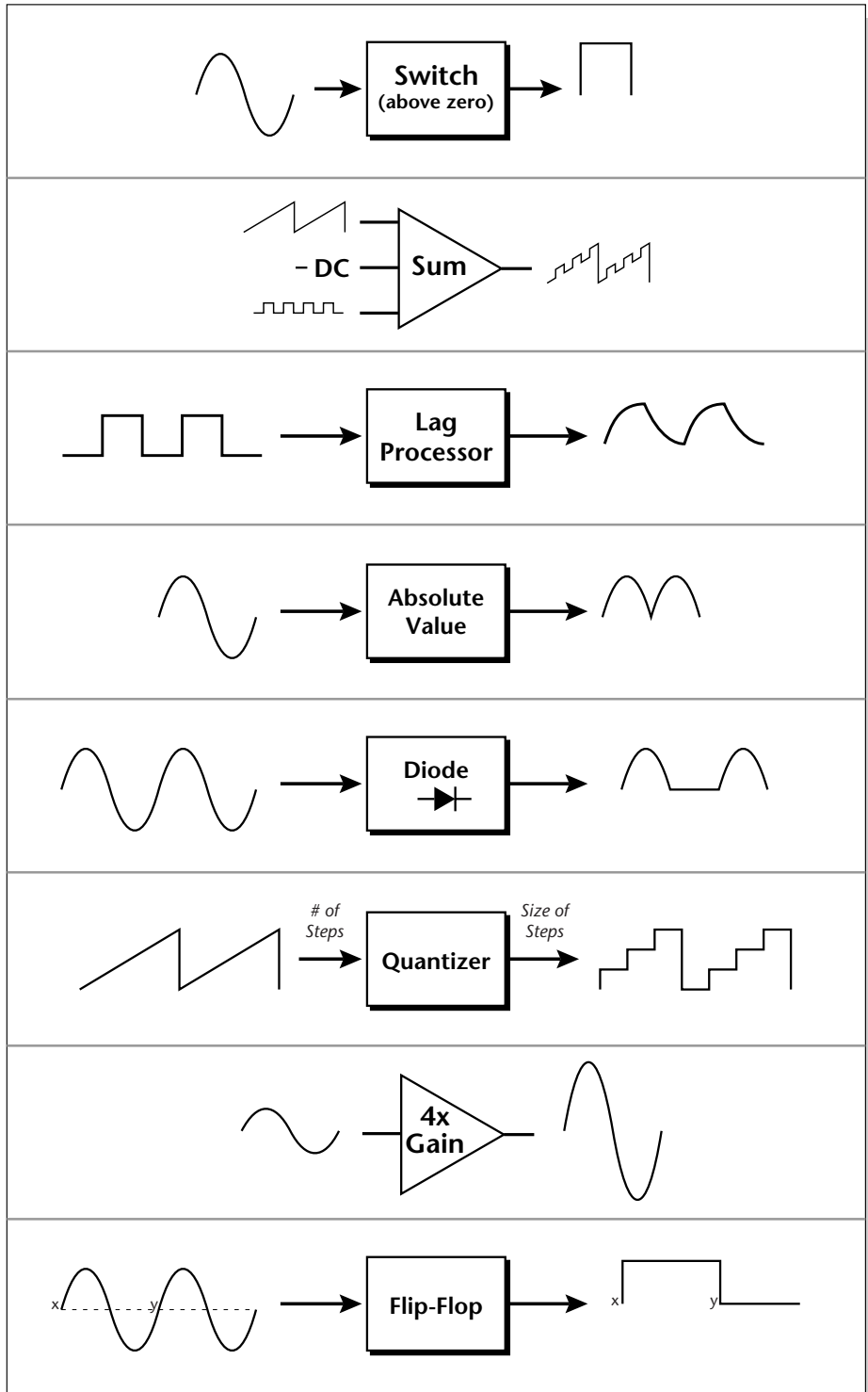

Modulation processors are inserted into a modulation routing as shown in the following diagram.

The modular analog synthesizers of yesteryear were incredibly flexible, partly because processing devices could be connected in any order. Modulation processors are designed according to this modular concept. They can be linked and used in a wide variety of ways limited only by your imagination. Consider the following example:

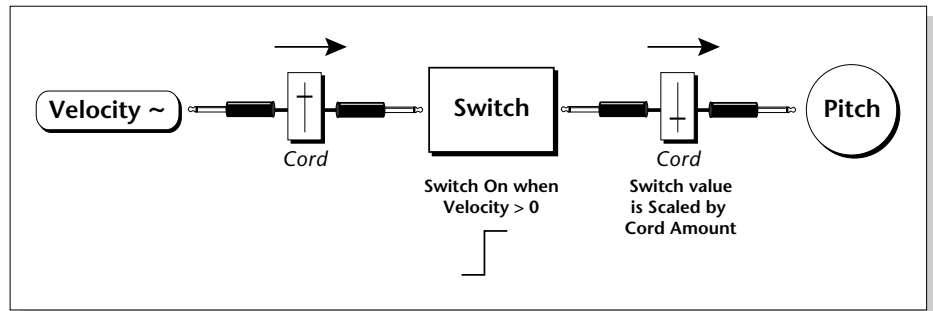

This patch would be programmed in the Cords screen as shown in the following illustration.

Cords 00 to 05				[M] V1: E0:F2			
z*	source	dest	amount	z*	source	dest	amount
00	:Vel~	Switch	+100%	03	:Off	Off	+0%
01	:Switch	Pitch	+22%	04	:Off	Off	+0%
02	:Off	Off	+0%	05	:Off	Off	+0%

Utils [Tuning Amp/Filt Lfo/Aux **Cords**]

This particular patch shifts the overall pitch up a fifth when the key velocity exceeds 64. Velocities below 64 will play at normal pitch and velocities of 64 and above will be raised a perfect fifth. The Velocity “~” source scales the played velocity around zero. In other words, low velocities (below 64) will have negative values and high velocities (64 and above) will be positive. A velocity of 64 would be zero. The Switch module only outputs a “1” if the input value is greater than zero. This digital “1” value can be scaled through the attenuator on the cord to raise or lower the pitch by any amount. In this case, a scaling value of +22 raises the pitch by a perfect fifth. The amount of the patchcord on the input to the switch is unimportant because ANY velocity value equal or greater than 64 will flip the switch. If the input cord amount were a negative value however, the action of the velocity would be reversed and velocities less than 64 would raise the pitch and velocities equal or greater than 64 would play the original pitch.

But what if you wanted the velocity switch point to be something other than 64? Thanks to the modulation processors, it can be done. Here's how.

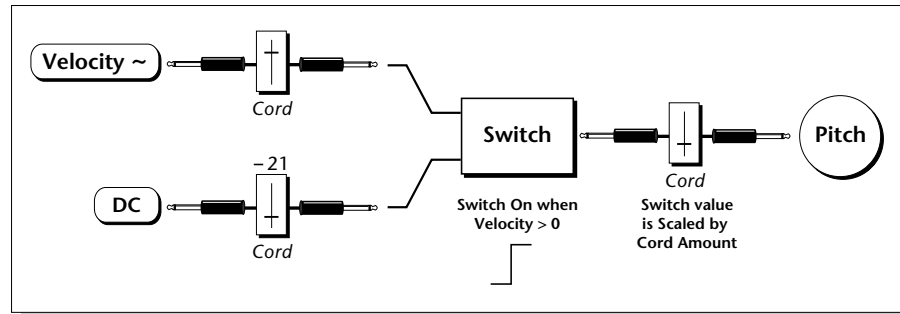

1. **Connect the DC level** to the input of the switch along with the velocity value. Note that more than one modulation source can be applied to the input of a processor.
The value of the DC offset determines the velocity switch point and is adjusted using the patchcord's attenuator.
2. **Set the DC amount** to a negative amount, higher velocity values are required to trip the switch. Setting the DC value to a positive value brings the velocity switch point down.

Following is the Cords screen for this patch.

Cords 00 to 05			IM1	V1: E0:F2		
source	dest	amount	source	dest	amount	
00 :Yel~	Switch	+100%	03 :Off	Off	+0%	
01 :Switch	Pitch	+22%	04 :Off	Off	+0%	
02 :DC	Switch	-21%	05 :Off	Off	+0%	

Utils [Tuning Amp/Filt Lfo/Aux Cords] ?-m:

Another example routes the Pink Noise generator through one of the Lag Processors in order to derive a smooth random function. A smooth random wave is useful in small amounts to add a degree of natural variation to timbre when routed to filter cutoff. Normal pink noise is low pass filtered audio frequency noise with a 3 dB/octave slope to give equal energy per octave. Our pink noise is actually more like very low frequency filtered (mauve) noise, but it is perfect for use as a random control source.

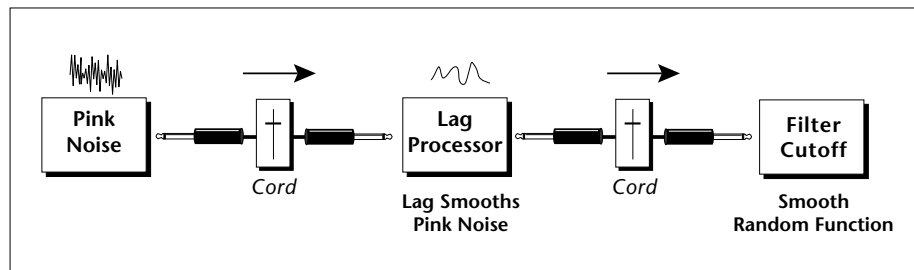

The Quantizer can generate interesting whole-tone scales when envelope generators or LFOs are routed to the input. The quantizer turns a smoothly changing input signal into a series of steps. By routing the output of the quantizer to Pitch and adjusting the cord amounts, you can control both the number of steps and the pitch interval of each step.

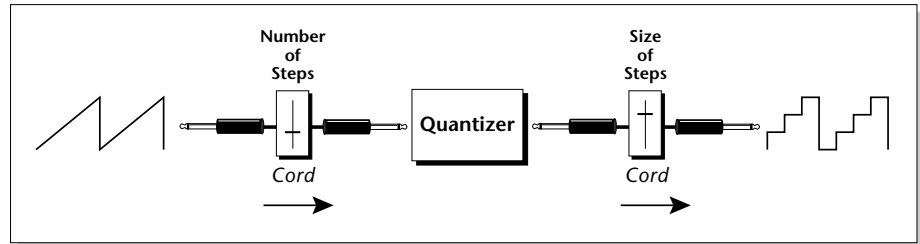

The input cord amount controls how many steps are generated. A sawtooth wave (LFO+) feeding the input, and the cord amount set to 100% generates sixteen steps. The output cord amount controls the size (or interval) of the steps.

Try setting up the following patch exactly as shown below using your favorite preset as a starting point.

 The 4x Amp can be used to get more steps or increase the interval of the quantizer.

LFO 1 IM1 V1: E0:F2

Rate :0.36 Sync: free run

Shape :sawtooth 

Delay :0

Variation :0%

Utils▲ [Tuning Amp/Filt Lfo/Aux Cords]

Cords 00 to 05 IM1 V1: E0:F2

source	dest	amount	source	dest	amount
00 :Lfo1+	Quantize	+100%	03 :Off	Off	+0%
01 :Quanti	Pitch	+100%	04 :Off	Off	+0%
02 :DC	Pitch	-50%	05 :Off	Off	+0%

Utils▲ [Tuning Amp/Filt Lfo/Aux Cords] ?<:m:

 Experiment with this patch by connecting other sources and destinations to the quantizer.

This patch generates an ascending arpeggio every time you press a key. The block diagram of the patch is shown on the following page. The patch is very straightforward except for the DC offset which was added in to bring the pitch down into tune. (Sometimes you have to fix a problem, but using the mod processors there's usually a way around it to achieve the desired result.)

8 - Preset Edit Modulation Processors

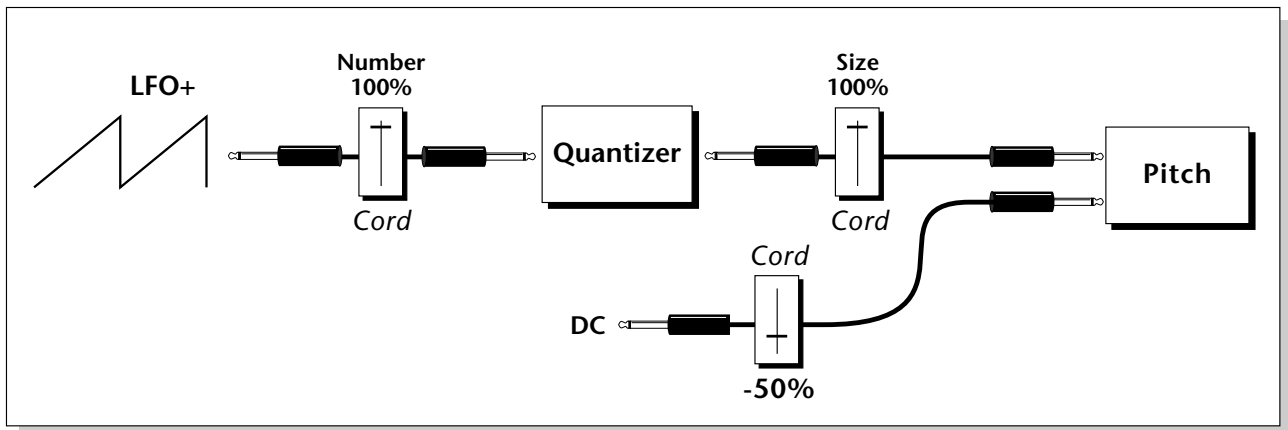

You can probably start to see some of the possibilities (and there are many). Whenever you find yourself wishing for some esoteric type of control, take a minute and think if there is a way to achieve the desired result using the modulation processors.

Dynamic Filters

Following is a block diagram of the signal path.

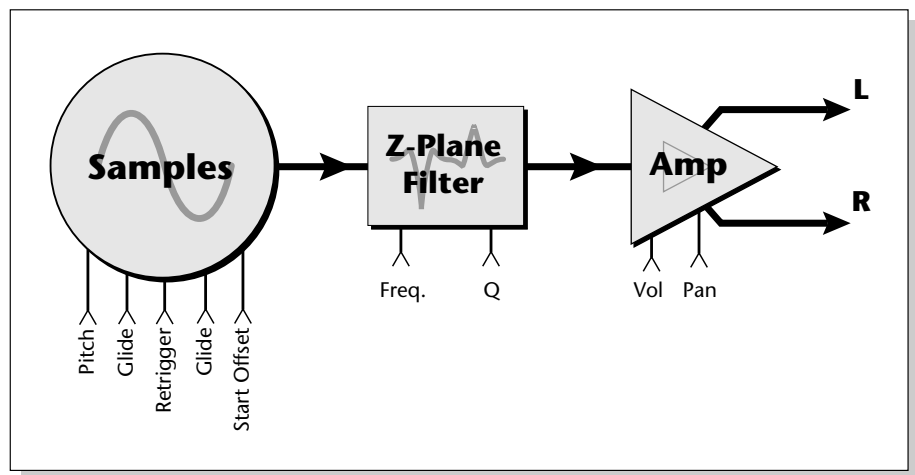

A Low Pass filter is a powerful synthesizer filter which can dramatically alter the sound of a sample.

To understand how a filter works, we need to understand what makes a sound wave. A sine wave is the simplest form of sound wave. Any waveform except a sine wave can be analyzed as a mix of sine waves at specific frequencies and amplitudes.

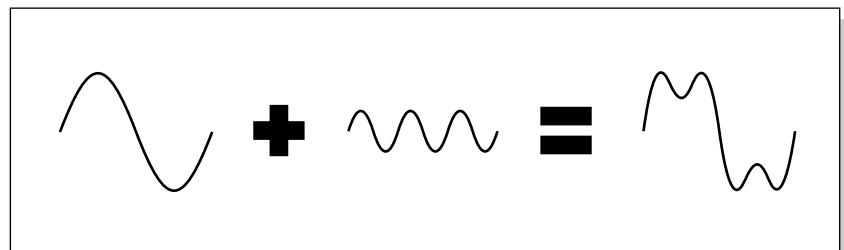

Any waveform can be analyzed as a mixture of sine waves.

8 - Preset Edit Dynamic Filters

One way to represent complex waveforms is to use a chart with frequency on one axis and amplitude on the other. Each vertical line of the chart represents one sine wave at a specific amplitude and frequency.

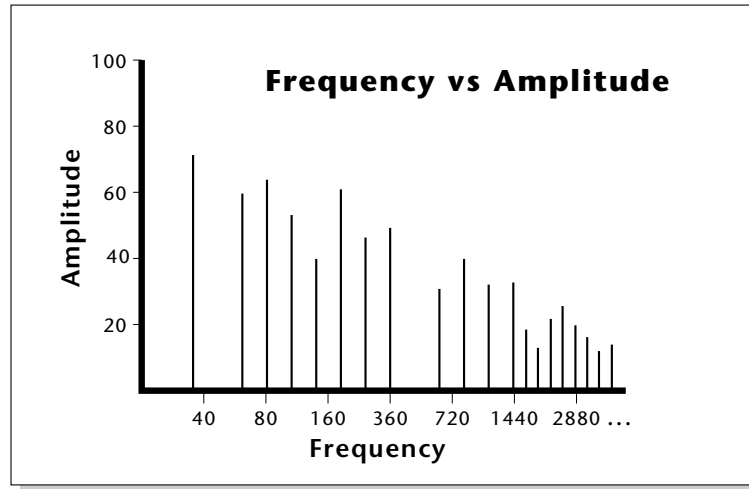

What is a Filter?

Most samples are complex waves containing many sine waves of various amplitudes and frequencies. A filter is a device which allows us to remove certain components of a sound depending on its frequency. For example, a Low Pass Filter lets the *low frequencies pass* and removes only the high frequencies.

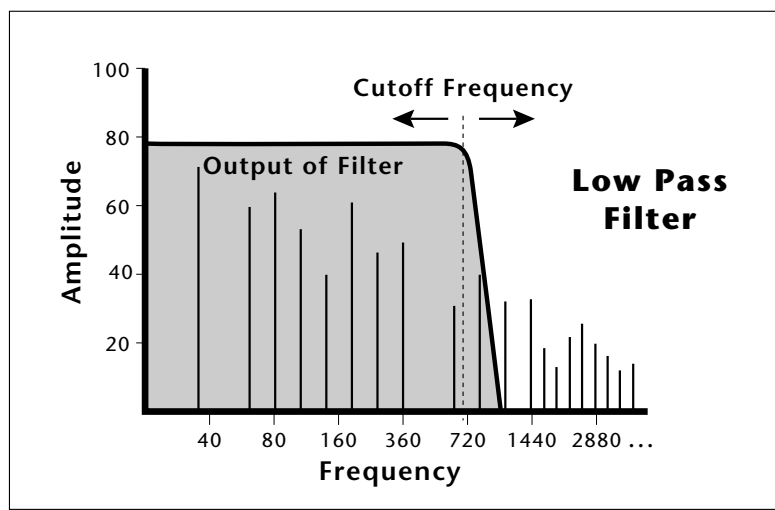

A filter that lets only the high frequencies pass is called a high-pass filter.

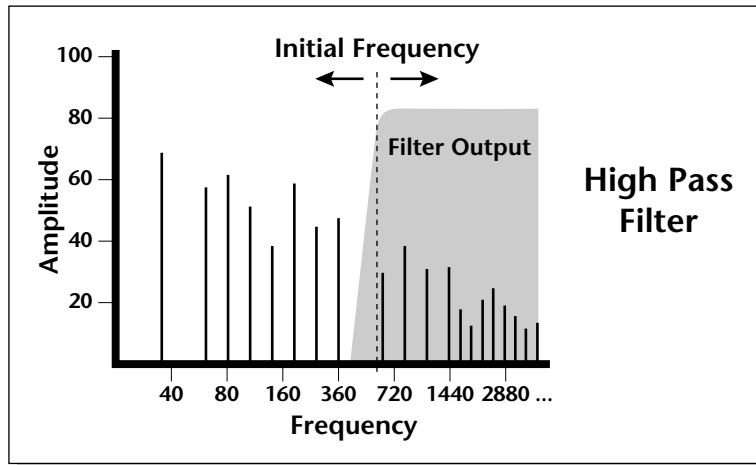

A filter that only lets a certain band of frequencies pass is called a band-pass filter.

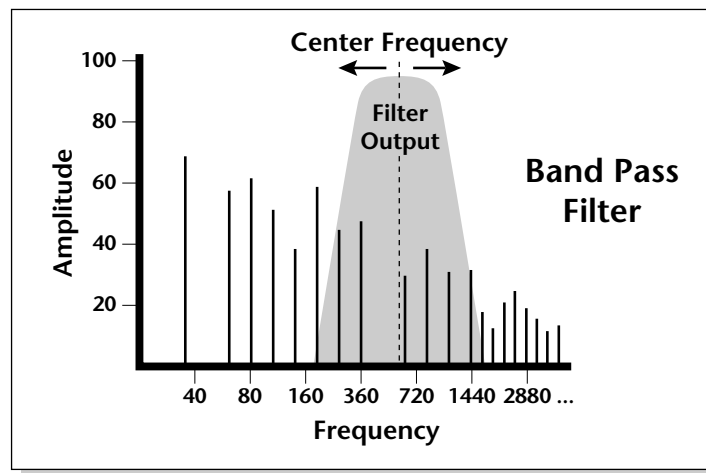

A Notch Filter is just the opposite of a bandpass filter and is used to eliminate a narrow band of frequencies.

Another control found on traditional filters is called Q or resonance. A lowpass filter with a high Q would emphasize the frequencies around the cutoff frequency. The following chart shows how different amounts of Q affect the low pass filter response. In terms of sound, frequencies around the cutoff tend to “ring” with high Q settings. If the filter is slowly swept back and forth, with a high Q, various overtones are “picked out” of the sound and amplified as the resonant peak sweeps over them. Bells and gongs are real world examples of sounds which have a high Q.

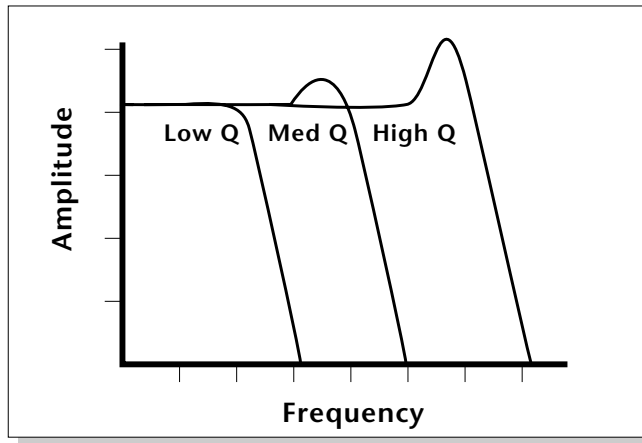

Another characteristic of a filter is the number of poles it contains. Traditional synthesizer filters were usually either

2-pole or 4-pole filters. The Emulator has a selectable 2, 4 or 6-pole low pass filter. The number of poles in a filter describes the steepness of its slope. The more poles, the steeper the filter's slope and the stronger the filtering action. The tone controls on your home stereo are probably one-pole or two-pole filters. Parametric equalizers are usually either two-pole or three-pole filters. In terms of vintage synthesizers, Moog and ARP synthesizers used 4-pole filters, Oberheim synthesizers were famous for their 2-pole filter sound.

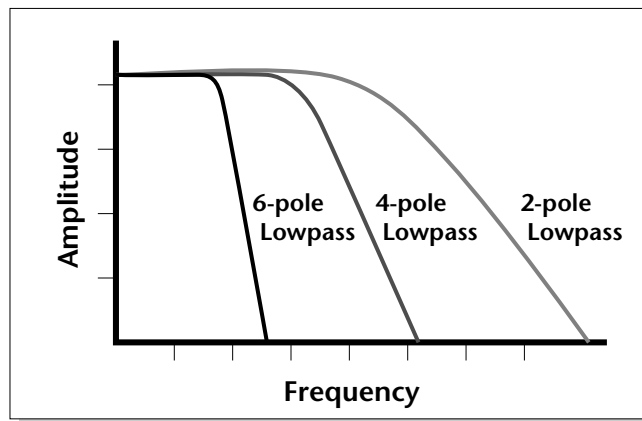

Using a filter, we now have a way to control the harmonic content of a sampled sound. As it turns out, even a simple low pass filter can simulate the response of many natural sounds.

For example, when a piano string is struck by its hammer, there are initially a lot of high frequencies present. If the same note is played softer, there will be fewer of the high frequencies generated by the string. We can simulate this effect by routing keyboard velocity to control the low pass filter. The result is expressive, natural control over the sound.

If an envelope generator is used to control the cutoff frequency of a filter, the frequency content can be varied dynamically over the course of the note. This can add animation to the sound as well as simulate the response of many natural instruments.

Parametric Filters

A more complex type of filter is called a parametric filter or Swept EQ. A parametric filter allows control over three basic parameters of the filter. The three parameters are: Frequency, Bandwidth, and Gain. The Frequency parameter allows you to select a range of frequencies to be boosted or cut, the Bandwidth parameter allows you to select the width of the range, and the Gain parameter either boosts or cuts the frequencies within the selected band by a specified amount. Frequencies not included in the selected band are left unaltered. This is different from a band pass filter which attenuates (reduces) frequencies outside the selected band.

Another parameter sometimes used on a parametric filter is Shelving. Shelving simply widens the passband so that it extends to the limit of the upper or lower frequency range.

The parametric filter is quite flexible. Any range of frequencies can be either amplified or attenuated. Several parametric sections are often cascaded in order to create complex filter response curves.

The Z-Plane Filter

A Z-plane filter is a filter which can change its function over time. In a Z-plane filter, we start with two complex filter types and interpolate between them using a single parameter. Refer to the diagram on the following page.

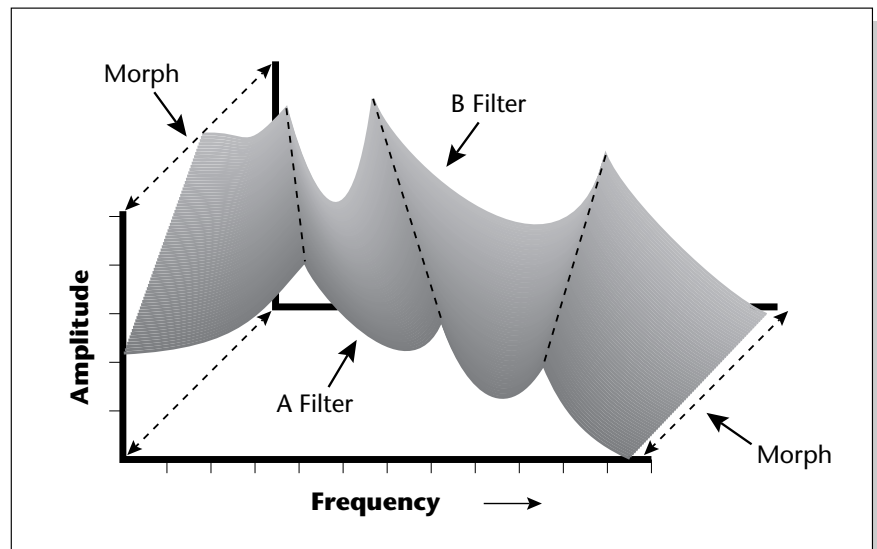

The Z-plane filter has the unique ability to change its function over time.

8 - Preset Edit

Dynamic Filters

Filters A and B represent two different complex filters or “frames”. By changing a single parameter, the Morph, many complex filter parameters can now be changed simultaneously. Following along the Morph axis you can see that the filter response smoothly interpolates between the two filters. This is the essence of the Z-plane filter. Through the use of interpolation, many complex parameters are condensed down into one manageable entity.

Consider, as an example, the human vocal tract, which is a type of complex filter or resonator. There are dozens of different muscles controlling the shape of the vocal tract. When speaking, however, we don't think of the muscles, we just remember how it feels to form the vowels. A vowel is really a configuration of many muscles, but we consider it a single object. In changing from one vowel to another, we don't need to consider the frequencies of the resonant peaks! You remember the shape of your mouth for each sound and interpolate between them.

This Z-plane filter sweep can be controlled by an envelope generator, an LFO, modulation wheels or pedals, keyboard velocity, key pressure, etc. In fact, any of the modulation sources can control the Z-plane filter.

Selecting Voices, Samples & Groups

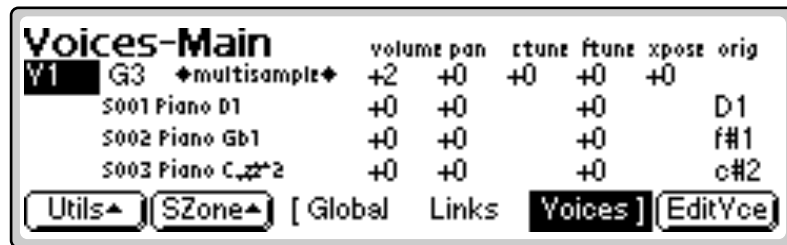

When working on complex sounds we need an easy way to specify certain voices or groups of voices for editing. There are several ways to select Voices, Samples and Groups.

Selecting from the Preset Editor Windows

To select Voices, Groups, or Samples from any of the preset editor windows you simply move the cursor to the appropriate field and press the **Edit** key (F6). The label on the Edit key changes depending on which type of item the cursor is on.

- When the cursor is on any **Voice-related Function**, the Edit key will select **Voice Edit**.
- When the cursor is on the **Group Number**, the Edit key will select the entire **Group**.
- When the cursor is on the **Sample Name**, the Edit key will select the **Sample** and will automatically jump into the Sample Edit menu.

Here's another little trick to help you select voices from the Preset Editor Windows.

- **Press and Hold the decimal point button** while playing a keyboard key to select that voice. Repeatedly pressing the keyboard key will rotate through any other voices assigned to that same key.

 The Preset Edit screens can be confusing because the module is divided into two parts (Preset Definition and Dynamic Processing). If you get confused, Exit the module and follow the steps shown.

Selecting All Voices

In many cases, you will want to select the entire keyboard. An easy way to Select All is to go to the Preset Globals page.

To Select all Voices

1. Press the **Preset Edit** button
2. Press the **Global** function key (F3).
3. Press the **Edit All** function key (F6). You have just selected all voices.

Selecting Voices from the Dynamic Processing Level

For power users, there is an automatic voice selection mode which selects voices whenever you play the keyboard.

To turn Automatic Voice Selection On:

1. Press the **Preset Edit** button
 2. Press the **Edit** function key (F6).
 3. Press the **Utils** function key (F1).
 4. Press the **VSelect** function key (F1).
 5. Press the **Auto** function key (F3).
 6. Press the **OK** function key (F6).
- Selecting a single note will select all voices assigned to that key.
 - Selecting a keyboard range by pressing two notes at once will select all voices within that range.

Now a few Words of Caution: When you play the keyboard to hear the results of your edit, **YOU ARE CHANGING THE VOICE SELECTION RANGE!** This can be confusing unless you remember to re-key the voice selection range before resuming editing.

Selecting Voices from the Voice Select Screen

There is also a special Voice Selection screen located in the Utilities menu of the Dynamic Processing level.

To Access the Voice Select Screen:

1. Press the **Preset Edit** button.
2. Press the **Edit** function key (F6).
3. Press the **Utils** function key (F1).
4. Press the **VSelect** function key (F1).

Groups

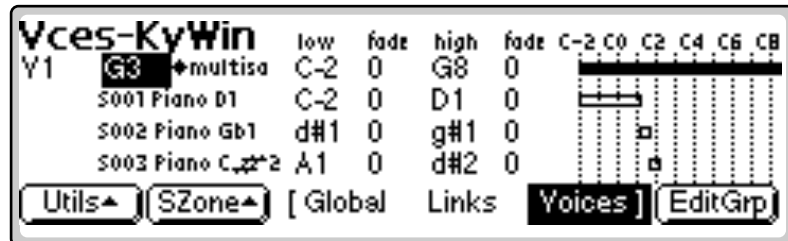

Dealing with a number of voices arranged on the keyboard can sometimes be a bit overwhelming. You might find yourself wishing there was a way to organize similar voices, say a layer of piano voices and a layer of string voices, into unified entities or Groups. That's it, groups!

To place a voice into a group, you simply tag each voice you want to be in the group with the same group number. Then, whenever you select that group number in the voice selection screen, all voices with that group number will be selected. You can define up to 32 groups, but a voice can only be in one group at a time.

Groups are assigned in any of the voice windows. In the Key Window shown above, two voices (1 & 3) are assigned to the same key range or in other words, they are layered. Note that they are also in two different groups. If you wanted to select voices 1 and 2, you could simply move the cursor to the Group 1 field in the key window shown above. The Edit key changes to read, "EditGrp." Simply press the EditGrp key (F6) to select all voices in group 1.

Preset Editor

The Preset Edit module puts everything together to build complete presets. Samples can be arranged into single-sample or multi-sample voices with synthesizer processing applied. These complete voices can then be arranged on the keyboard.

The Preset Editor contains two levels. The top level, called **Preset Definition**, is used for editing global preset parameters, linking presets and for arranging voices and samples on the keyboard. The lower level, called **Dynamic Processing**, is used to perform more detailed editing of one or more preset voices such as envelope shaping of amplitude and filters as well as modulation parameters.

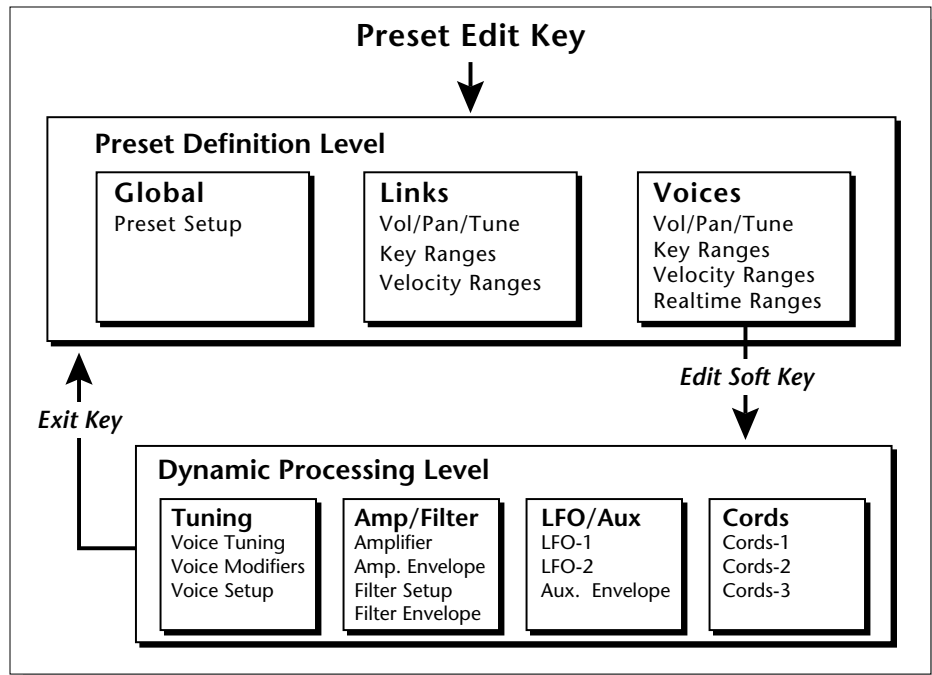

The dynamic processing parameters are accessed by pressing the Edit function key while in one of the Voice screen parameters (or directly via an assignable key). Multiple voice selection is supported in any of the Dynamic Processing editing screens using a MIDI keyboard (Auto Voice Select).

 The Preset Editor remembers which page was last displayed and returns to that same page when the Preset Edit button is again pressed. When the EXIT button is pressed, while in any Dynamic Processing editor screen, the last-displayed Preset Editor screen will reappear (unless the preset is changed).

The Preset Definition level contains three main pages (Global, Links, Voices) which are selected using a function key. Each page will be highlighted while it is selected.

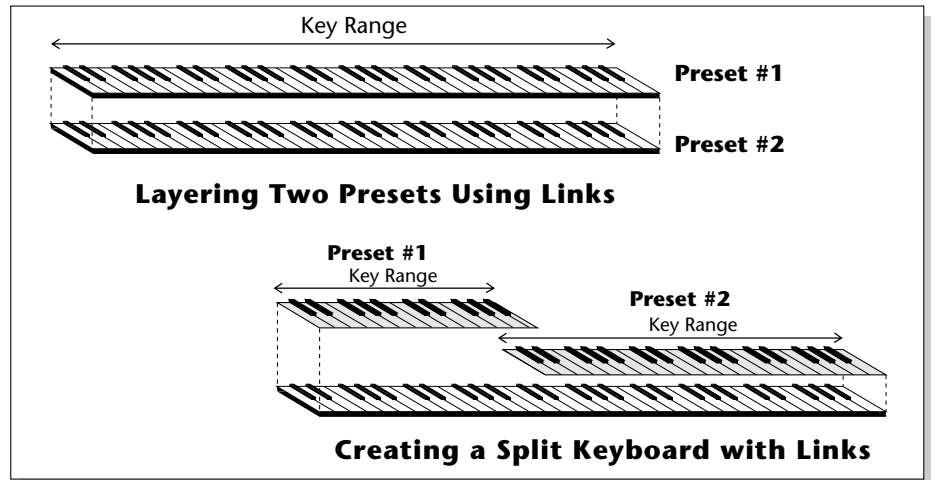

Global Editor . Contains the parameters Preset Transpose and Preset Volume which affect all voices in the preset. Also contains the Preset FX menus (*Press the Next button*).

Links. Call up other presets in the bank which can be used to create layering or keyboard splits. Linked presets are not altered by linking. They are simply called up from memory and played. An easy way to layer, crossfade or split sounds is to link presets in an empty preset. See New Link. Each linked preset can have its own keyboard range, velocity range, volume, pan position, and tuning.

Link can also control an external MIDI channel. For example, you could split the keyboard and have the lower half control internal presets and the upper half controlling another sound module on MIDI channel 5.

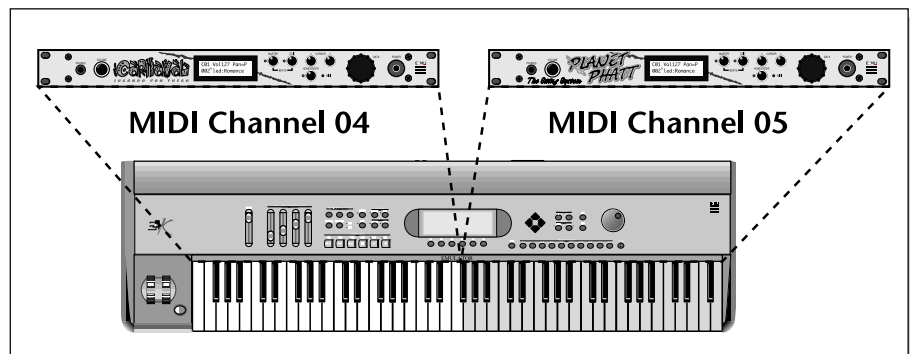

This is called a MIDI Link. MIDI Links can be assigned to any keyboard range or can be scaled according to velocity. This allows you to use the E4K as a Master Controller keyboard and split or layer the keyboard up to 16 ways with a different synthesizer on each MIDI channel.

PostScript error (invalidfont, findfont)



MIDI Links re-transmit data received on the Emulator's Basic MIDI Channel (Master, MIDI).

On an Emulator rack unit, MIDI Links can process and re-output incoming MIDI data from your keyboard. This allows any MIDI keyboard to become a Master keyboard with multiple split points and layering.

Voice Editing. Allows you to place voices and samples on the keyboard and crossfade or switch between them according to key position, velocity range and realtime control range. This submodule also contains parameters to adjust the tuning, volume and pan position for the voices and samples.

If a voice contains more than one sample, it will be labeled as a multi-sample and the individual samples will be listed below it. Voices are shown graphically as solid black bars and samples are shown as empty bars. If a voice contains only one sample, then the sample will be the voice name.

PRESET EDIT - Global



Global Editor

Transpose & Volume: These are global parameters which affect the entire preset.

Initial Controllers A-D: These set the initial value of MIDI controllers A-D. On the E4K and E-Synth Keyboard, they set the initial values of the front panel realtime control sliders. As soon as a controller is moved, it jumps immediately from the initial setting to the actual setting of the control.

 *The realtime sliders on the E4K and E-Synth Keyboard are permanently assigned to controllers A-D.*

To Change the Global Parameters:

1. Press the **Preset Edit** button. The LED illuminates and the main preset edit screen appears.
2. Press the **Global** function key (F3). The preset global page appears.
3. Adjust the **Volume** and **Transpose** interval for the preset.
4. Set up the **initial realtime slider settings** for the preset.
5. Press the **Links** or **Voices** function keys to continue in Preset Edit or press the **Preset Edit** button to exit the module.

Edit All

This extremely handy function key **Selects All Voices** and jumps immediately into the dynamic processing level of the voice editor. This key is the fastest way into the editor when you want to work on all voices at once.

Preset Effects A

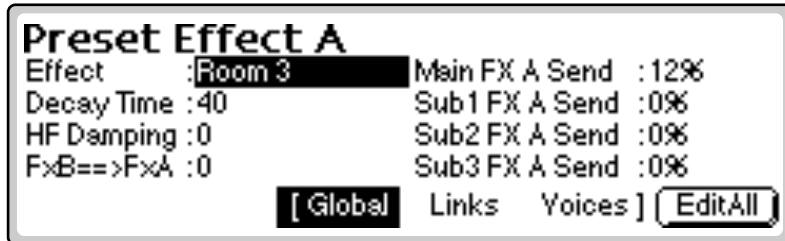

The Preset Effects settings are normally used whenever you are in Omni or Poly mode. This allows the effects to be programmed as part of the preset. Because there are only two effects processors for the entire machine, effects cannot be programmed separately for each preset in Multimode.

If the Effect parameter is set to "Master Effect", the effects setting in the Master module is used. This system allows the effects to be assigned per preset or globally for all presets. There are two effects processors— Effect "A" and Effect "B". "A" type effects consist mainly of reverbs.

The Preset Effects are accessed from the Preset Global submenu by pressing the Next button.

 Effects can be programmed in the Preset or in the Master module. The Control/FX Key and Shift/FX Key take you to the effects module that is currently in use.

Pressing the FX key repeatedly rotates through the effects menus.

Effects Programmed in the Preset

When playing single presets the effects are normally programmed as part of the preset.

To Program the Effects as part of the Preset:

1. Press the **Preset Edit** button. The LED illuminates and the Preset Edit screen appears.

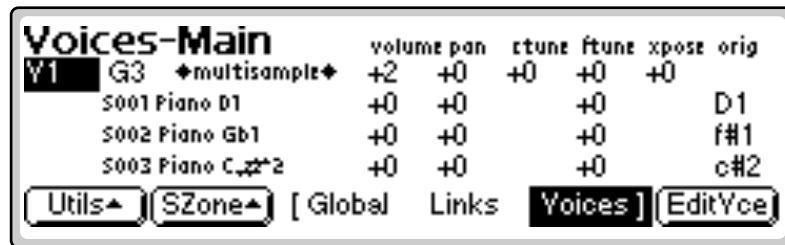

If you are in a screen where the “Global, Links, Voices” function keys are not visible, press the Exit button once.

2. Press the **Global** function key (F3). The Global menu appears.
3. Press the **Next** page button. The Preset Effect A menu appears.

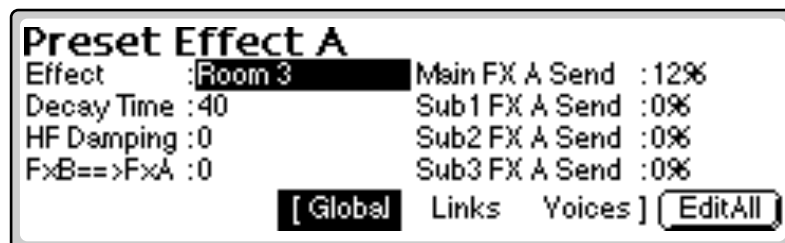

4. **Select an Effect.** Do not use the “Default” setting as this will cause the Master effect settings to be used. Set the other effect parameters to your preference.
5. Press the **Next** page button again to go to the Preset Effect B menu.
6. **Save the bank.** The programmed effects settings will be saved along with the preset.

 **Note:** A warning message appears if an effect routing other than “Preset” is currently selected.

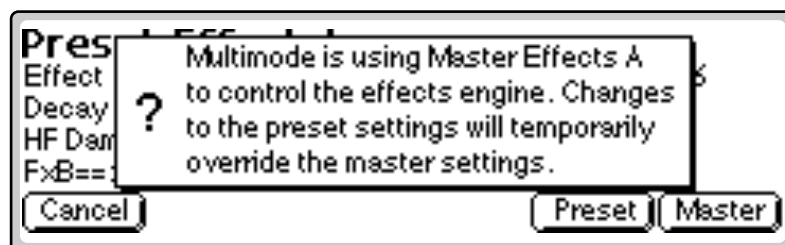

8 - Preset Edit

Effects Programmed in the Preset

Effect

This function selects the type of effect used. The following effects are currently available:

A EFFECT TYPES

Room 1-3	Hall 1 & 2
Plate	Delay
Panning Delay	Multitap 1
Multitap Pan	3 Tap
3 Tap Pan	Soft Room
Warm Room	Perfect Room
Tiled Room	Hard Plate
Warm Hall	Spacious Hall
Bright Hall	Bright Hall Pan
Bright Plate	B-Ball Court
Gymnasium	Cavern
Concert 9	Concert 10 Pan
Reverse Gate	Gate 2
Gate Pan	Concert 11
Medium Concert	Large Concert
Large Concert Pan	Canyon
DelayVerb 1-3	DelayVerb 4-5 Pan
DelayVerb 6-9	



Pressing Shift/FX (or Controls on the E4K or E-Synth Keyboard) will jump to the Effects menu (either Master FX or Preset FX) that is currently in use. Repeated pressing of the key cycles through the effects menus.

To Change the Effect Type:

1. Press the **Preset Edit** button. The LED illuminates and the Preset Edit screen which was last used appears.
2. Press the **Global** function key (F3). The Preset Globals menu appears.
3. Press the **Next** page button. The Effects A menu appears.
4. Move the cursor to the **Effect** field using the cursor buttons.
5. Select the desired effect type using the Data Entry Control, or INC/DEC buttons.
6. Press the **Exit** button to return to the main screen.

Decay Time

This parameter sets the length of time it will take an effect to fade away. In the case of reverb, decay time controls the room size and the reflectivity of the room. On a delay effect, decay time controls how many echoes are produced or how long the echoes will last.

To Change the Decay Time:

1. Press the **Preset Edit** button. The LED illuminates and the Preset Edit screen which was last used appears.
2. Press the **Global** function key (F3). The Preset Globals menu appears.
3. Press the **Next** page button. The Effects A menu appears.
4. Move the cursor to the Decay Time field using the cursor buttons.
5. Set the **Decay Time** using the Data Entry Control, or INC/DEC buttons.
6. Press the **Exit** button to return to the main screen.

HF Damping

High frequency energy tends to fade away first as a sound is dissipated in a room. This parameter allows you adjust the amount of high frequency damping and thus change the characteristics of the room. Rooms with smooth, hard surfaces are more reflective and have less high frequency damping. Rooms filled with sound absorbing materials such as curtains or people have more high frequency damping.

To Change the High Frequency Damping:

1. Press the **Preset Edit** button. The LED illuminates and the Preset Edit screen which was last used appears.
2. Press the **Global** function key (F3). The Preset Globals menu appears.
3. Press the **Next** page button. The Effects A menu appears.
4. Move the cursor to the **HF Damping** field using the cursor buttons.
5. Adjust the **HF Damping** parameter using the Data Entry Control, or INC/DEC buttons.
6. Press the **Exit** button to return to the main screen.

FX Amounts

The Effects Amount controls the percentage of effected (wet) signal to un-effected (dry) signal. This function would be analogous to the effect sends on a mixing console. The effects amount for each of the four stereo outputs can be individually controlled.

To Change the Effects Amount:

1. Press the **Preset Edit** button. The LED illuminates and the Preset Edit screen which was last used appears.

8 - Preset Edit

Effects Programmed in the Preset

2. Press the **Global** function key (F3). The Preset Globals menu appears.
3. Press the **Next** page button. The Effects A menu appears.
4. Move the cursor to the desired FX Amount field using the cursor buttons.
5. Adjust the **FX Amount** using the Data Entry Control, or INC/DEC buttons.
6. Press the **Exit** button to return to the main screen.

FX B Through FX A

The output of effect processor B can be routed into effect processor A. This connects the effects in series instead of their normal parallel configuration. The BflA amount can also be controlled for even more flexibility.

☞ To Send the Output of Effect B through Effect A:

In this example, 100% of Effect B will be sent into Effect A.

1. The Effect A screen (in either the Master or Preset Edit menus) contains the B->A Amount parameter. **Set this amount to 100%.**
2. **Turn the Send Amounts down to zero** since we only want to hear the two effects in series.
3. Press the **Next** page button to select Effect B. Select an effect and adjust the Main FX B Send percentage as desired.
4. **Play the keyboard** and you should hear the B Effect running through Effect A.

See chapter 3 - *Effects* for more information.

Preset Effects B

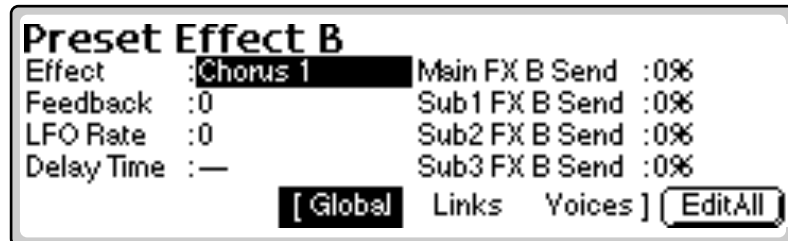

The Preset Effects settings are normally used whenever you are in Omni or Poly mode. This allows the effects to be programmed as part of the preset. Because there are only two effects processors for the entire machine, effects cannot be programmed separately for each preset in Multimode.

If the Effect parameter is set to "Master Effect B", the effects settings in the Master module are used and the parameters in the Preset Effects become unavailable. This system allows the effects to be assigned per preset or globally for all presets. "B" type effects consist mainly of chorus, flange and digital delay effects.

The Preset Effects B can be accessed from the Preset Global submenu by pressing the Next button twice.

Effect B

This function selects the type of effect used. The following effects are currently available:

B EFFECT TYPES

Chorus 1-5	Doubling
Slapback	Flange 1-7
Big Chorus	Symphonic
Ensemble	Delay
Delay Stereo 1 & 2	Panning Delay
Delay Chorus	Pan Delay Chorus 1 & 2
Dual Tap 1/3	Dual Tap 1/4
Vibrato	Distortion 1 & 2
Distorted Flange	Distorted Chorus
Distorted Double	



See chapter 3, FX for detailed information on the effects.

To Change the Effect Type:

1. Press the **Preset Edit** button. The LED illuminates and the Preset Edit screen which was last used appears.
2. Press the **Global** function key (F3). The Preset Globals menu appears.
3. Press the **Next** page key twice. The Effects B menu appears.
 - **Alternate Method:** Pressing Shift/FX (or Controls on the E4K) will jump to the Effects menu (either Master FX or Preset FX) that is currently in use. Repeated pressing of the key cycles through the effects menus.
4. **Move the cursor to the Effect field** using the cursor buttons.
5. **Select the desired effect type** using the Data Entry Control, or INC/DEC buttons.
6. Press the **Exit** button to return to the main screen.

Feedback Amount

The Chorus and Flange effects have a controllable feedback loop after the delay element. Feeding back a small amount of the signal intensifies the effect by creating multiple cancellations or images.

To Change the Feedback Amount:

1. Press the **Preset Edit** button. The LED illuminates and the Preset Edit screen which was last used appears.
2. Press the **Global** function key (F3). The Preset Globals menu appears.
3. Press the **Next** page button twice. The Effects B menu appears.
4. Move the cursor to the desired **Feedback Amount** field using the cursor buttons.
5. Adjust the **Feedback Amount** using the Data Entry Control, or INC/DEC buttons.
6. Press the **Exit** button to return to the main screen.

LFO Rate

Chorus and flange effects use a Low Frequency Oscillator to animate the effect. LFO applied to a chorus effect creates the slight changes necessary for a realistic choral effect. Applied to a flanger, the LFO moves the comb filter notches and adds animation to the sound.

☞ To Change the LFO Rate:

1. Press the **Preset Edit** button. The LED illuminates and the Preset Edit screen which was last used appears.
2. Press the **Global** function key (F3). The Preset Globals menu appears.
3. Press the **Next** page key twice. The Effects B menu appears.
4. Move the cursor to the **LFO Rate** field using the cursor buttons.
5. Set the **LFO Rate** using the Data Entry Control, or INC/DEC buttons.
6. Press the **Exit** button to return to the main screen.

Delay Time

Flanging, chorus and echoes are all based on a delay line where the signal is delayed by some time period and mixed back together with it's un-delayed signal. This parameter varies the length of the delay or "how much time" passes before you hear the delayed signal. On some effects, this parameter is not adjustable, indicated by a dash in the field.

☞ To Change the Delay Time:

1. Press the **Master** button. The LED illuminates and the Memory Statistics screen appears.
2. Press the **Output** function key (F4). The Output menu appears.
3. Press the **Next** page button twice. The Effects B menu appears.
4. Move the cursor to **Delay Time** using the cursor buttons.
5. Adjust the **Delay Time** parameter using the Data Entry Control, or INC/DEC buttons.
6. Press **Exit** to return to the main screen.

FX Amounts

The Effects Amount controls the percentage of effected (wet) signal to un-effected (dry) signal. This function would be analogous to the effect sends on a mixing console. The effects amount for each of the four stereo outputs can be individually controlled.

☞ To Change the Effects Amount:

1. Press the **Preset Edit** button. The LED illuminates and the Preset Edit screen which was last used appears.
2. Press the **Global** function key (F3). The Preset Globals menu appears.
3. Press the **Next** page key twice. The Effects B menu appears.
4. Move the cursor to the desired **FX Amount** field using the cursor buttons.
5. Adjust the **FX Amount** using the Data Entry Control, or INC/DEC buttons.
6. Press the **Exit** button to return to the main screen.

Preset Edit - Links

Link Preset
name & number

Link Type
internal/external

Link Controls
Volume, Pan, Coarse/Fine Tuning

Link Field

External Link

Link Field	Link Preset name & number	Link Type internal/external	Volume	Pan	xpose	ftune
L1	P003 Synth Pad	Internal	-18	+0	+0	+0
L2	P040 Singing Electric	Internal	-10	+0	+0	+0
L3	prgm 0, bank 0	Ext/c01	+0	+0	+0	+0

Utils

[Global **Links** Voices]

Displays Global Editor Pages

Displays Voice Editor Pages

Button is highlighted while this page set is displayed.

New - adds link to preset
Delete - deletes link from preset
Copy - copies link to any preset
Subsume - copies voices of the linked preset into the current preset.

PAGE

◀ PREV NEXT ▶

Use the Page keys to access the Key & Velocity windows.

Main Controls

Link Field: Link can be selected using the numeric keypad or Data Entry Control. A Link can be an internal preset or an external MIDI device. A MIDI Program Change command will also be sent if it is a MIDI Link.

Link Preset Name & Number: The linked preset can be changed using the Data Entry Control or INC/DEC buttons.

Link Controls: These controls offset the volume, pan, transpose and fine tuning controls of the linked preset.

Utilities: New, Delete, Copy, and Subsume.



MIDI Links can only be used in Omni or Poly modes.



On an Emulator Rack Unit, MIDI Links can filter and re-transmit data received on the Basic MIDI Channel.

This allows any MIDI keyboard to become a powerful master controller.

Link Type

Links can be made to one or more internal presets or to one or more external MIDI devices.

MIDI Links allow your keyboard to control up to 16 external MIDI devices with multiple split points and layers. When a MIDI Link is selected, the preset field selects a MIDI program change which will be transmitted (on the selected MIDI channel) when the preset is first selected.

To Change the Link Type:

1. Press the **Preset Edit** button. The LED illuminates and the last page selected appears.
2. Press the **Links** function key (F4) to select the link page of the editor. The link function key will be highlighted.
3. Use the **Cursor** buttons to select the “Link Type” field. If there are no Links in the preset, you can create one using the New Utility.
4. Set the “**Type**” parameter to internal or to external MIDI channel using the Data Entry Control or INC/DEC buttons.
5. Use the **Cursor** buttons to select other Link parameters.
6. Press the **Exit** button to return to the main preset selection screen.

Link Volume

This function allows you to adjust the volume of the linked preset relative to the main preset. When a MIDI Link is selected an initial volume message (Channel Volume - Controller 7) will be transmitted when the preset is selected.

The internal values of -96 to +10 are scaled to correspond to MIDI volume values. A value of +10 corresponds to MIDI Volume 127 and -96 corresponds to MIDI volume 0.

To Change the Link Volume:

1. Press the **Preset Edit** button. The LED illuminates and the last page selected appears.
2. Press the **Links** function key (F4) to select the link page of the editor. The link function key will be highlighted.
3. Use the **Cursor** buttons to select the Volume field. If there are no Links in the preset, you can create one using the New Utility.
4. Change the **Volume** parameter to the desired value using the Data Entry Control or the INC/DEC buttons.
5. Use the **Cursor** buttons to select other Link parameters or press the **Exit** button to return to the main preset selection screen.

Link Pan

This function allows you to set the left /right pan position for the selected link. When a MIDI Link is selected, an initial pan message (Channel Pan - Controller 10) will be transmitted when the preset is first selected.

To Change the Link Pan Position:

1. Press the **Preset Edit** button. The LED illuminates and the last page selected appears.
2. Press the **Links** function key (F4) to select the link page of the editor. The link function key will be highlighted.
3. Use the **Cursor** buttons to select the Pan field. If there are no Links in the preset, you can create one using the New Utility.
4. Change the **Pan** parameter to the desired value using the Data Entry Control or the INC/DEC buttons.
5. Use the **Cursor** buttons to select other Link parameters or press the **Exit** button to return to the main preset selection screen.

Link Transpose

This function allows you to transpose the key of the link in semitone intervals by shifting the keyboard position relative to middle C. The transpose range is -24 to +24 semitones. When a MIDI Link is selected, the external MIDI notes are transposed by the selected amount.

To Transpose a Link:

1. Press the **Preset Edit** button. The LED illuminates and the last page selected appears.
2. Press the **Links** function key (F4) to select the link page of the editor. The link function key will be highlighted.
3. Use the **Cursor** buttons to select the "Xpose" field. If there are no Links in the preset, you can create one using the New Utility.
4. Change the **Transpose** parameter to the desired value using the Data Entry Control or the INC/DEC buttons.
5. Use the **Cursor** buttons to select other Link parameters or press the **Exit** button to return to the main preset selection screen.

Link Fine Tuning

This function allows you to change the tuning of the Linked preset in 1/64 semitone intervals (approx. 1.56 cents). The fine tuning range is ± 1 semitone. Fine tuning can be used to slightly detune a preset, creating a “fatter” sound when it is combined with another preset. This parameter has no effect when a MIDI Link is selected.

To Fine Tune a Link:

1. Press the **Preset Edit** button. The LED illuminates and the last page selected appears.
2. Press the **Links** function key (F4) to select the link page of the editor. The link function key will be highlighted.
3. Use the **Cursor** buttons to select the “Ftune” field. If there are no Links in the preset, you can create one using the New Utility.
4. Change the **Fine Tune** parameter to the desired value using the Data Entry Control or the INC/DEC buttons.
5. Use the **Cursor** buttons to select other Link parameters or press the **Exit** button to return to the main preset selection screen.

Link Utilities

New Link

Creates a new link field.

To Create a New Link:

1. Press the **Preset Edit** button. The LED illuminates and the last page selected appears.
2. Press the **Links** function key (F4) to select the link page of the editor. The link function key will be highlighted.
3. Press the **Utils** function key (F1). A second row of function keys appears.
4. Press the **New...** function key (F1). A new link field will be added to the list of preset links.
5. Press **Exit** if you wish to cancel the operation.

To Create a Huge Stacked Preset the Easy Way:

1. Load any bank of presets.
2. Press the **Preset Manage** button. Press the **New** key to create a new blank preset.
3. **Select a location** for the new blank preset and name it if desired.
4. Press the **Preset Edit** button.
5. Press the **Links** function key (F4) to select the link page of the editor. The link function key will be highlighted.
6. Press the **Utils** function key (F1). A second row of function keys appears.
7. Press the **New...** function key (F2). A new link field will be added to the list of preset links.
8. Move the **Cursor** to the preset field and select a preset.
9. **Repeat steps 6 and 7** until the desired thickness has been achieved.
10. Press **Exit** to leave the Utilities menu.

Copy Link

Copies a link and its parameters to and from any preset.

To Copy a Link:

1. Press the **Preset Edit** button. The LED illuminates and the last page selected appears.
2. Press the **Links** function key (F4) to select the link page of the editor. The link function key will be highlighted.
3. **Select the Link** you wish to copy using the up/down cursor buttons or the Data Entry Control when the link field is selected.
4. Press the **Utils** function key (F1).
5. Press the **Copy** function key (F4). The pop up dialog box shown below appears.



6. Select the source and destination presets
7. Select the source link to be copied.
8. Press **OK** to copy the link or **Cancel** to cancel the operation.

Delete Link

Removes the selected link field.

To Delete a Link:

1. Press the **Preset Edit** button. The LED illuminates and the last page selected appears.
2. Press the **Links** function key (F4) to select the link page of the editor. The link function key will be highlighted.
3. **Select the Link** you wish to delete using the up/down cursor buttons or the Data Entry Control when the link field is selected.
4. Press the **Utils** function key (F1). A second row of function keys appears.
5. Press the **Delete** function key (F3). A pop up dialog box appears asking you to confirm the operation.
6. Press **OK** to delete the link or **Cancel** to cancel the operation.

Subsume Link

Copies all the voices of the linked preset into the current preset.

 Use the Subsume function as another way to create presets.

1. Create a new preset.
2. Link the presets you want.
3. Subsume Link to pull all the voices into the current preset.

To Subsume a Linked Preset:

1. Press the **Preset Edit** button. The LED illuminates and the last page selected appears.
2. Press the **Links** function key (F4) to select the link page of the editor. The link function key will be highlighted.
3. **Select the Link** you wish to subsume using the up/down cursor buttons or the Data Entry Control when the link field is selected.
4. Press the **Utils** function key (F1). A second row of function keys appears.
5. Press the **Subsume** function key (F5). The pop up dialog box shown below appears.



6. **Select the Starting Group number.** This will place the voices from the linked preset in groups beginning with the starting group number. If the voices in the linked preset were not grouped, they will all be placed into the starting group number.
7. Press **OK** to subsume the link or **Cancel** to cancel the operation.

Links - Key Window

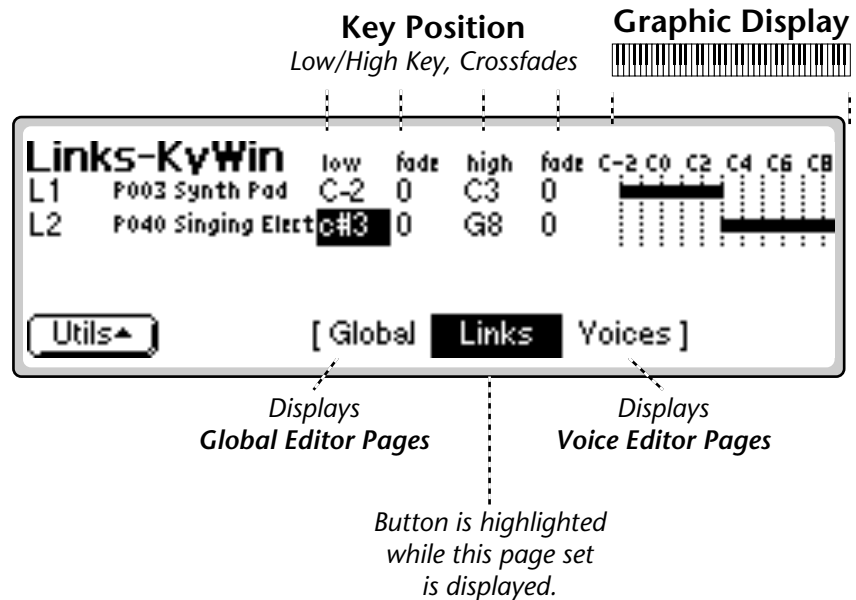

The Key Window of the Links screen is accessed by pressing the Next Page button on the front panel from the main Links screen. The screen shown above appears. Note: If there are no links in the preset, the display will inform you of this fact. Press Utilities, then New... to create a new link.

Key Window Controls

Link Field: Link can be selected using the numeric keypad or Data Entry Control.

Link Preset Name & Number: The linked preset can be changed using the Data Entry Control or INC/DEC buttons.

Key Position Controls: These controls set the high and low key range and the crossfade range in keys for each linked preset. When an External Link is selected the Key Position Controls set the limits of the transmitted MIDI notes out. MIDI volume to the external MIDI device will be scaled according to the Fade settings

Graphic Display: Shows the keyboard positions of each link.

Utilities: New, Delete, Copy, and Subsume.

Keyboard & Velocity Ranges

When editing the keyboard and velocity ranges of preset links, an editing screen similar to the one shown on the previous page appears.

The bars at the right side of the screen give a graphic display of how the presets are placed on the keyboard. The key position is edited by placing the cursor over the desired parameter and then playing the MIDI keyboard or adjusting the Data Entry Control.

To Positionally Crossfade

The Fade parameters allow the volume of the preset to be faded out as a function of key position. In the Link screen shown below, the two presets are being positionally crossfaded over a range of one octave.

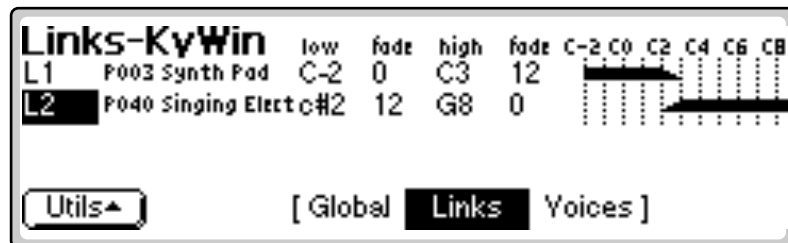

As you play up the keyboard in the C2-C3 octave range, the Synth Pad preset will gradually fade out as the Singing Electric preset fades in. This is shown on the display by the range bars fading out and in.

This technique can help mask the point at which two sounds meet. The presets are assigned so that they overlap by a few keys, then the fades are programmed so that one sound fades out as the other fades in.

 Note: Make sure the external devices are set up to respond to MIDI channel volume.

- If two External Links were selected in the example above, using two different MIDI channels instead of two different presets, the volumes of the two external devices would be positionally crossfaded over the one octave range between C2 and C3.

Links - Velocity Window

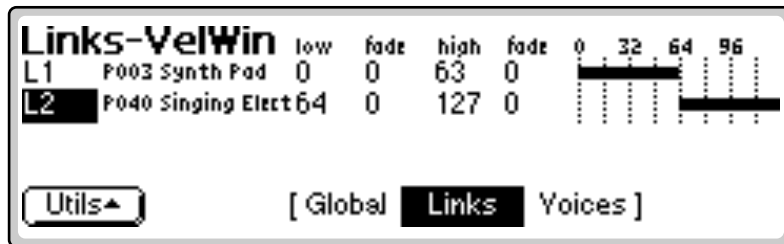

The Velocity Window of the Links screen is accessed by pressing the Next Page button on the front panel from the Key Window Links screen. A screen similar to the one shown above appears. In the screen above, the two presets will be “velocity-switched” at a key velocity of 64.

Velocity Window Controls

Link Field: The link can be selected using the numeric keypad or Data Entry Control.

Link Preset Name & Number: The linked preset can be changed from this window using the Data Entry Control or INC/DEC buttons.

Velocity Controls: These controls set the high and low key range and the crossfade range (in keys) for each linked preset. When an External Link is selected, the Velocity Window limits the MIDI notes according to velocity. Velocity values to the external MIDI device will be scaled according to the Fade settings

Graphic Display: Shows the velocity ranges of each link.



If the key ranges do not overlap, you will not hear the effects of the velocity controls.

Velocity Range

The Links - Velocity Range window allows you to control the volume of a preset (or external MIDI device) using key velocity. You might want to switch or crossfade between a piano and string preset depending on the keyboard velocity, or switch between several percussion presets. Velocity switching between Links makes it easy.

To Velocity-Switch Between Presets or MIDI channels:

To switch between two sounds according to velocity, their Key Ranges must first overlap. Normally you would set the Key Ranges so that they completely overlap one another, then set the Velocity Ranges so they are adjacent to each other.

For example, set one velocity range to 0-63 and the other to 64-127.

To Velocity Crossfade Presets or MIDI Channels:

To crossfade between two presets or MIDI channels according to velocity, their key ranges must overlap. Normally you will set the key ranges to the same range, as in the screen below.



 External MIDI devices respond differently than internal presets. A velocity crossfade causes the MIDI velocity value to be scaled, but velocity may not be routed to volume on the external MIDI device.

The default velocity range is from 0-127 or full range. Both presets will sound regardless of what velocity is played. Set the velocity range of each sound. The next screen shows the velocity ranges set so that preset link 1 fades out the higher the key velocity, while preset link 2 fades in, the higher the key velocity. At a velocity of 64, the two sounds will be equal volume.

Adjust the fade-in and fade-out points to achieve a natural sounding crossfade. The actual crossfade points will vary depending on the sounds.

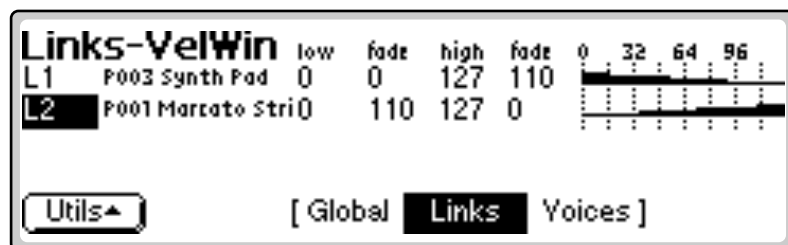

Links - MIDI Filters



The MIDI Filter Window of the Links screen is accessed by pressing the Next Page button on the front panel from the Velocity Window Links screen. A screen similar to the following appears.

You may want some of your linked presets (or external devices) to ignore continuous controllers such as the pitch wheel or keyboard pressure. The MIDI Filters allow you to enable or disable MIDI controllers for any of your external links.

In the screen above, the Pitch and Modulation wheels are being filtered out for external link 3. In other words, the external device will respond to all controllers except pitch and mod wheels.

MIDI Filter Window Controls

- **Filter:** MIDI controllers can be disabled for any linked preset or external link. The following controllers can be filtered out.

Pitch Wheel	Mod. Wheel
Channel Pressure	Control Pedal
Controller A	Controller B
Controller C	Controller D
Footswitch 1	Footswitch 2
Thumb Button	



 **To Filter a Controller from a Link:**

1. Press the **Preset Edit** button. The LED illuminates and the last page selected appears.
2. Press the **Links** function key (F4) to select the link page of the editor. The link function key will be highlighted. If there are no Links in the preset, as indicated in the display, you can create one using the New Utility.
3. Press the **Next Page** button three times. The screen shown above appears.
4. Use the **Cursor** buttons to select the field to be filtered.
5. Use the Data Entry Control or INC/DEC buttons to select a controller to be filtered. Controllers to be filtered are indicated by an "X" in the field.
6. Use the **Cursor** buttons to select other Link parameters or press the **Exit** button to return to the main preset selection screen.

Preset Edit - Voices

Voice/Group Number	Voice/Sample Name or Multisample	Parameters Volume, Pan, Coarse/Fine Tuning Transpose, Original Key					
Y1	G3 multisample	volume	pan	ctune	ftune	xpose	orig
	S001 Piano D1	+2	+0	+0	+0	+0	D1
	S002 Piano Gb1	+0	+0		+0		f#1
	S003 Piano C, #2	+0	+0		+0		c#2

Buttons: [Utils] [SZone] [Global] Links [Voices] [EditYce]

Annotations:

- New** - adds a voice to the preset
- Delete** - deletes voice or sample zone from the preset
- Copy** - copies voice to any preset
- Split** - splits the voice into two
- Global Editor Pages** - Displays Global Editor Pages
- Link Editor Pages** - Displays Link Editor Pages
- Voices** - Button is highlighted while this page set is displayed.

Sample Zone Utilities:

- New** - Adds a new sample zone to the voice.
- Get Multisample** - Replaces only the multisamples in a voice.
- Delete** - Deletes a sample zone from the voice.
- Combine** - Creates one multisample from all the voices.
- Expand** - Creates individual voices from multisamples.

See Voice Tuning in this chapter for detailed explanations of the Volume, Pan, Tuning and Transpose controls.

The volume of a voice is dependent on many volume parameters. If Voice Volume doesn't seem to work properly, check all the other volume points in the patch.

Voices - Main Controls

Voice/Group Number: The voice can be selected using the numeric keypad, INC/DEC buttons, or Data Entry Control. The group number can be changed in the same manner.

Samples: The samples contained in the voice are displayed and can be edited.

Utilities.

Sample Zone Utilities.

Parameters: Initial settings for volume, pan, coarse/fine tune, and transpose. The original key (where the actual sample is placed) can also be edited here.

Voice Utilities

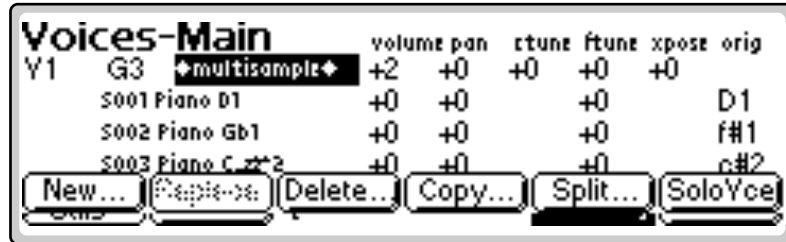

New Voice

This function creates a new voice.

To Create a New Voice:

1. Press the **Preset Edit** button. The LED illuminates and the main preset edit screen appears.
2. Press the **Voices** function key (F5) to select the voice edit page of the editor. The Voices function key will be highlighted.
3. Press the **Utils** function key (F1). Another row of function keys appears.
4. Press the **New...** function key (F1). A pop up window will inform you that a new voice is being added.

Copy Voice

This function allows you to copy a voice from any preset to any other preset.

To Copy a Voice:

1. Press the **Preset Edit** button. The LED illuminates and the main preset edit screen appears.
2. Press the **Voices** function key (F5) to select the voice edit page of the editor. The Voices function key will be highlighted.
3. Press the **Utils** function key (F1). Another row of function keys appears.



4. Press the **Copy...** function key (F4). A pop up window appears. Select the source preset, source voice and the destination preset.
5. Press **OK** to copy the selected voice or **Cancel** to cancel the operation.

 The Delete Voice function does not erase the samples.

Delete Voice

This function deletes the selected voice.

To Delete a Voice:

1. Press the **Preset Edit** button. The LED illuminates and the main preset edit screen appears.
2. Press the **Voices** function key (F5) to select the voice edit page of the editor. The Voices function key will be highlighted.
3. Press the **Utils** function key (F1). Another row of function keys appears.
4. **Select the voice** you wish to delete using the cursor buttons or by keying in the voice number when the cursor is over the voice number field.
5. Press the **Delete** function key (F3). A pop up window will inquire if you really want to erase the selected voice.
6. Press **OK** to erase the selected voice or **Cancel** to cancel the operation.

Split Voice

This function splits the selected voice into two voices. You can split a voice in order to separate and process two ranges of keyboard separately. The edit parameters of the two voices will be identical.

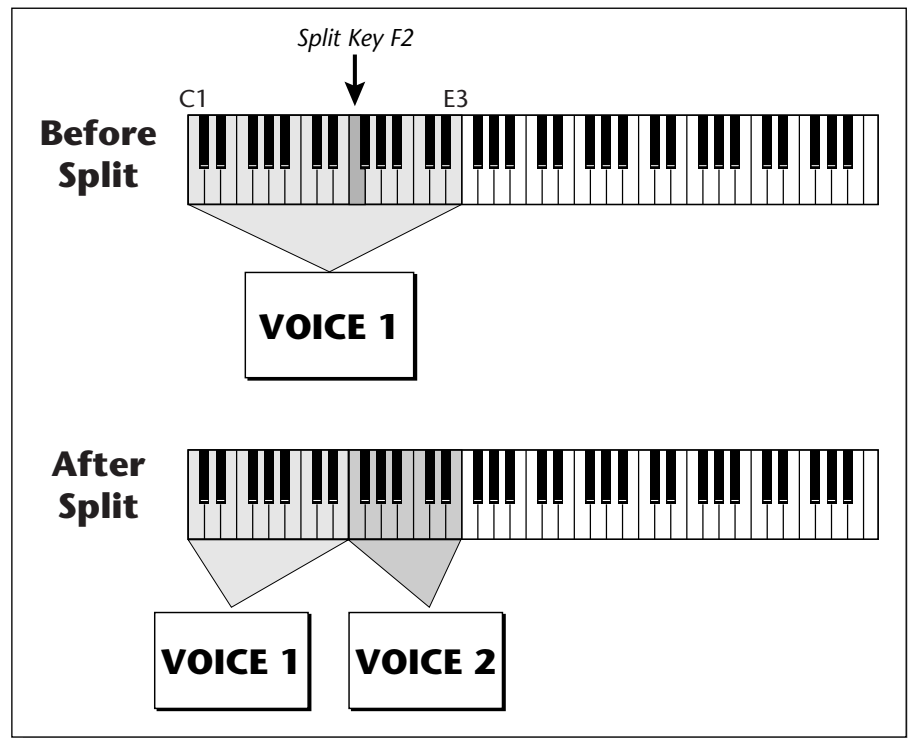

 **To Split a Voice:**

1. Press the **Preset Edit** button. The LED illuminates and the main preset edit screen appears.
2. Press the **Voices** function key (F5) to select the voice edit page of the editor. The Voices function key will be highlighted.
3. **Select the voice** you wish to split using the cursor buttons or by keying in the voice number when the cursor is over the voice number field.
4. Press the **Utils** function key (F1). Another row of function keys appears.
5. Press the **Split** function key (F5). A pop up window appears with an option to set the split key. The voice will be split just below the split key.

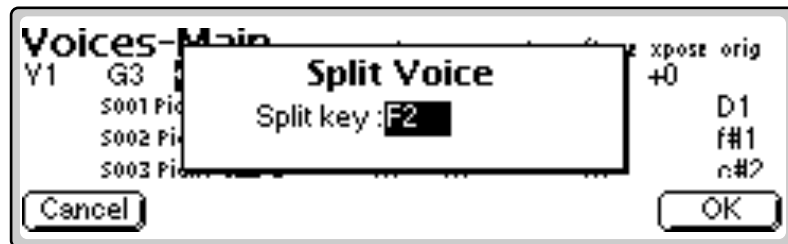

6. Press **Yes** to split the voice or **No** to cancel the operation.

Solo Voice

When Solo Voice is activated only the currently selected voice will be heard. **The voice number will be flashing** to remind you that the voice is soloed. Solo voice works both in the Preset Definition level and the Dynamic Processing level of the Preset Editor.

 You cannot solo groups of voices. Solo mode gets turned Off when more than one voice is selected.

 **To Solo a Voice:**

1. Press the **Preset Edit** button. The LED illuminates and the main preset edit screen appears.
2. Press the **Voices** function key (F5) to select the voice edit page of the editor. The Voices function key will be highlighted.
3. Press the **Utils** function key (F1). Another row of function keys appears.
4. Press the **SoloVce** function key (F6). The row of function keys will disappear and the Voice indicator on the top line of the display will be flashing.
5. **Select the individual voice** you want to hear using the cursor keys.
6. Press **Utils** and then **SoloOff** to turn Solo Voice Off.

Sample Zone

 The "greyed out" button over F4 is a place holder for future expansion.

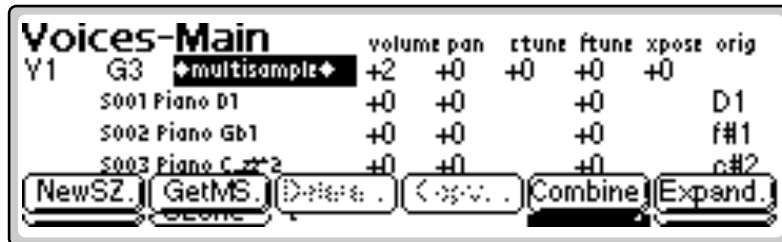

This submodule contains several utility functions relating to Sample Zones.

New Sample Zone

This function creates a new sample zone.

To Create a New Sample Zone:

1. Press the **Preset Edit** key. The LED illuminates and the main preset edit screen appears.
2. Press the **Voices** function key (F5) to select the voice edit page of the editor. The Voices function key will be highlighted.
3. **Select the voice** to which the sample zone will be added using the cursor keys or by keying in the voice number when the cursor is over the voice number field. You may also select a sample in the case of a multisample.
4. Press the **SZone** function key (F2). Another row of function keys (shown above) appears.
5. Press the **NewSZ...** function key (F1). A pop up window will inform you that a new sample zone is being added.

 Certain functions will be "greyed out" if their function is not applicable to the current voice or sample zone selection.

Get Multisample

This utility allows you to replace the currently selected samples of a voice with those of any other voice in the bank. This function does not replace the dynamic processing parameters of the voice. **Only the samples are replaced.** This feature allows you to use existing voices as templates. Simply drop in new multisamples to voices you have copied to create a new preset.

☞ To Replace a Multisample:

1. Press the **Preset Edit** key. The LED illuminates and the main preset edit screen appears.
2. Press the **Voices** function key (F5) to select the voice edit page of the editor. The Voices function key will be highlighted.
3. **Select the voice** you want to receive the new multisample.
4. Press the **SZone** function key (F2). Another row of function keys appears.
5. Press the **GetMS** function key (F2). The following pop up window appears.



6. **Select the source preset** for the multisample. The samples in this voice will replace those in the currently selected voice.
7. **Select the source multisample.**
8. Press **OK** to replace the multisample or **Cancel** to cancel the operation.

Delete Sample Zone

This function deletes a sample zone from the voice.

☞ To Delete a Sample Zone:

1. **Select the sample** you wish to delete from one of the voice edit pages. Delete is disabled when you have a voice and not a sample selected.
2. Press the **SZone** function key (F2). Another row of function keys appears.
3. Press the **Delete** key (F3). A pop up dialog box will ask you if you really want to delete the selected sample.
4. Press **OK** to delete the sample or **Cancel** to cancel the operation.

Combine

This function takes all voices in a group and combines them into one multisampled voice. The dynamic processing information of the first voice is used for the new voice. Any dynamic processing information associated with the other voices is lost.

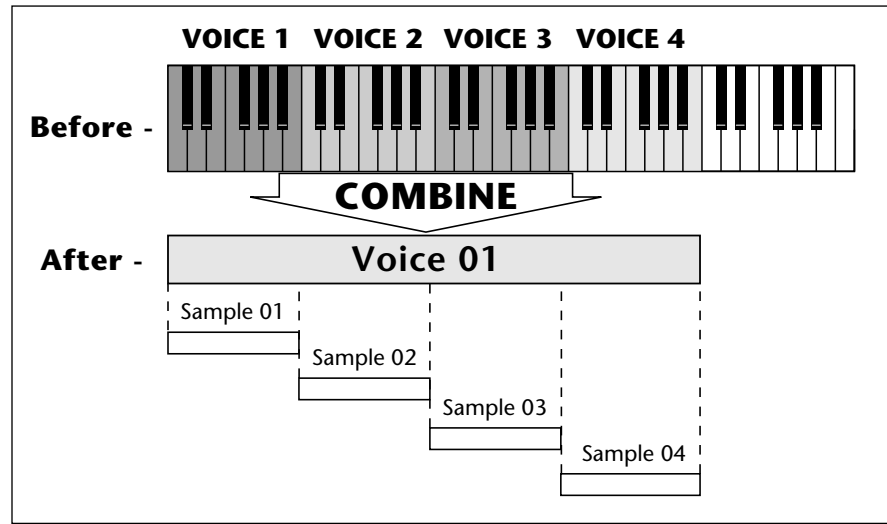

To Combine Voices:

1. Press the **Preset Edit** key. The LED illuminates and the main preset edit screen appears.
2. Press the **Voices** function key (F5) to select the voice edit page of the editor. The Voices function key will be highlighted.
3. Press the **SZone** function key (F2). Another row of function keys appears.
4. Press the **Combine** function key (F5). A pop up window appears allowing you to select a group of voices to be combined.
5. Select the **Group** containing the voices you want combined.
6. Press **OK** to continue or **Cancel** to cancel the operation.
7. Another pop up window appears warning you that by combining the voices you are discarding the voice data from all but the first voice.
8. Press **OK** to combine the voices or **Cancel** to cancel the operation.

Expand...

This function takes apart the multisampled voices in a bank and makes an individual voice for each sample. The dynamic processing information of the “parent” voice is duplicated for each newly created voice.

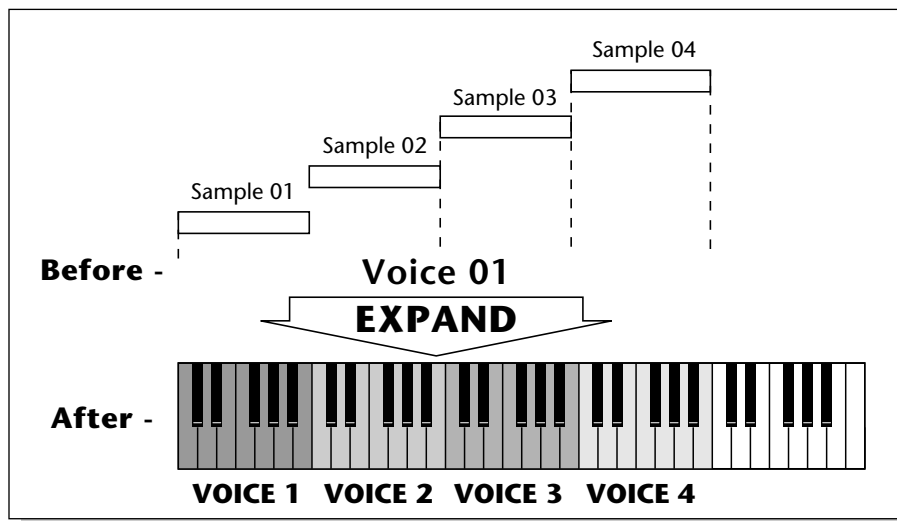

To Expand Multisampled Voices:

1. Press the **Preset Edit** key. The LED illuminates and the main preset edit screen appears.
2. Press the **Voices** function key (F5) to select the voice edit page of the editor. The Voices function key will be highlighted.
3. Press the **SZone** function key (F2). Another row of function keys appears.
4. Press the **Expand..** function key (F6). A pop up window appears allowing you to select a group of voices to be expanded.
5. **Select the group** containing the voices you want expanded.
6. Press **OK** to expand the voices or **Cancel** to cancel the operation.

Voices - Key Window

Key Position
Low/High Key, Crossfades

Graphic Display

Vces-KyWin		low	fade	high	fade	C-2	C0	C2	C4	C6	C8
V1	G1	S042 KM G	C-2	0	G2	0					
V2	G1	S043 KM G	g#2	0	C3	0					
V3	G1	S044 KM G	c#3	0	F3	0					
V4	G1	◆multisa	f#3	0	C7	0					

Utils▲ SZone▲ [Global Links **Voices** EditYce

Displays Global Editor Pages

Displays Link Editor Pages

Button is highlighted while this page set is displayed.

The Key Window of the Voices screen is accessed by pressing the **Next Page** key on the front panel from the main Voices screen. The previous screen appears.

Key Window Controls

Voice Field: Link can be selected using the numeric keypad or Data Entry Control.

Group Field: The group number of the voice can be changed using the numeric keypad or Data Entry Control.

Sample Name & Number: The voice's sample(s) can be changed using the Data Entry Control or INC/DEC keys.

Key Position Controls: These controls set the high and low key range and the crossfade range in keys for each voice and sample.

Graphic Display: Shows the keyboard positions of each voice and sample.

Utilities: New, Copy, Delete, and Split.

Sample Zone: New Sample Zone, Get Multisample, Delete Sample Zone, Combine and Expand.

Edit: Voice Selection & Dynamic Processing parameters.

Keyboard Ranges

When a sample is recorded, it is automatically placed in a voice and assigned a keyboard range specified in the “Auto-Placement” parameters in the Sample Management module. The Key Range Window allows you to edit these assignments and place the voices and samples wherever you want.

 Remember to **SAVE** the bank to disk or all your programming will be lost.

Key Position **Graphic Display**
Low/High Key, Crossfades 

Vces-KyWin			low	fade	high	fade	C-2	C0	C2	C4	C6	CB
V1	G1	◆multisa	C-2	0	G8	0						
	S001 Piano D1		A-1	0	F0	0						
	S001 Piano D1		F#0	0	B0	0						
	S001 Piano D1		C1	0	D1	0						

Displays Global Editor Pages *Button is highlighted while this page set is displayed.*
Displays Link Editor Pages

A voice containing only one sample takes the name of the sample. If a voice contains more than one sample, it is called a “◆multisample◆” and the samples it contains are listed below it.

 To create a really high quality voice, you might want to sample every third note or even every note.

The bars at the right side of the screen give a graphic display of how the voices and samples are assigned to the keyboard. Voices are shown as solid black bars, while Samples are displayed as hollow bars. Voice keyboard range assignments supersede the assignments of the samples they contain.

More samples are usually better, but the playing technique used while sampling becomes critical the more samples are used!

The key position is edited by placing the cursor over the desired parameter and then playing the MIDI keyboard or adjusting the Data Entry Control. Voices and samples can be crossfaded according to key position by adjusting the low and high fade parameters. The fade is adjusted in “number of keys” and is graphically represented by a gradual decrease in the height of the bars.

To Switch Voices According to Position

Assigning voices (samples or multisamples) adjacent to each other is the simplest and most common application of the Key Window. This is also the way samples are “Auto-Placed” in the Sample Manage module. The voices in the screen below are each assigned a one octave range.

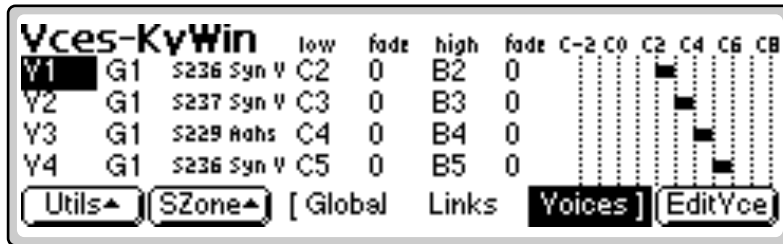

 Samples can be arranged in a voice in exactly the same way that voices are arranged on the keyboard. They can be arranged side by side on the keyboard to minimize the negative effects of pitch shifting or stacked on top of each other to create huge layered sounds, all within a single voice.

Another way of visualizing this assignment is shown below.

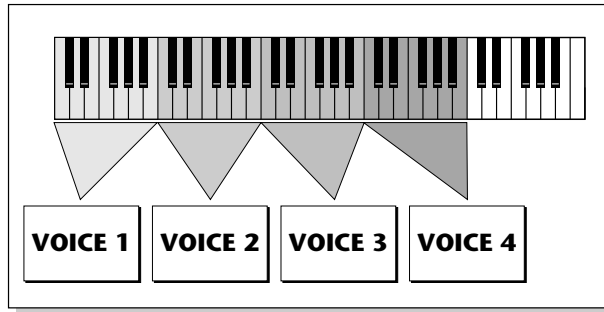

To Layer Voices and Samples

The ranges of two or more voices may overlap, and all voices assigned to a key will sound.

1. Press the **Preset Edit** key. The LED illuminates and the main preset edit screen appears.
2. Press the **Voices** function key (F5) to select the voice edit pages of the editor. The Voices function key will be highlighted.
3. Press the **Next Page** key. The Voices - Key Window appears.
4. Edit the **High** and **Low** keys of the voice ranges so they overlap as shown in the screen below. Both voices will now sound when their key range is played.

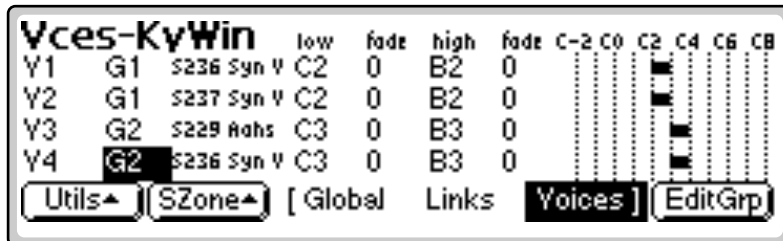

Another way of visualizing this assignment is shown below.

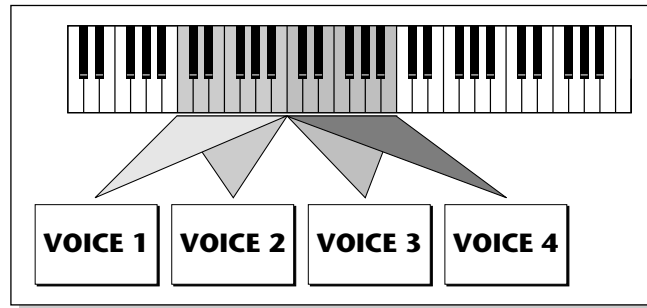

 You may want to assign voices in different layers to different groups. This allows you to select all of the voices in each layer just by selecting the group number. You can edit the group number of a voice in any of the Voice screens.

 **To Positionally Crossfade:**

This technique can help mask the point at which two sounds meet. The fade parameters allow the volume of the voice or sample to be faded out as a function of key position. In the screen shown below, voices 1 and 2 are being positionally crossfaded over a range of five notes.

As the voice boundaries are crossed playing up the keyboard, the lower voice gradually fades out as the upper voice fades in.

Vces-KyWin		low	fade	high	fade	C-2	C0	C2	C4	C6	CB
Y1	G1	S236	syn V	C2	0	D3	0				
Y2	G2	S237	syn V	A2	0	B3	0				
Y3	G3	S229	Aahs	C4	0	B4	0				
Y4	G3	S236	syn V	C5	0	B5	0				

 These same techniques work when assigning samples within multisampled voices.

1. Press the **Preset Edit** key. The LED illuminates and the main preset edit screen appears.
2. Press the **Voices** function key (F5) to select the voice edit pages of the editor. The Voices function key will be highlighted.
3. Press the **Next Page** key. The Voices - Key Window appears.
4. Edit the **High** and **Low** keys of the voice ranges so they overlap as shown below, then set the low and high fades for the two voices. In the center of the crossfade range, both voices will at equal volume.

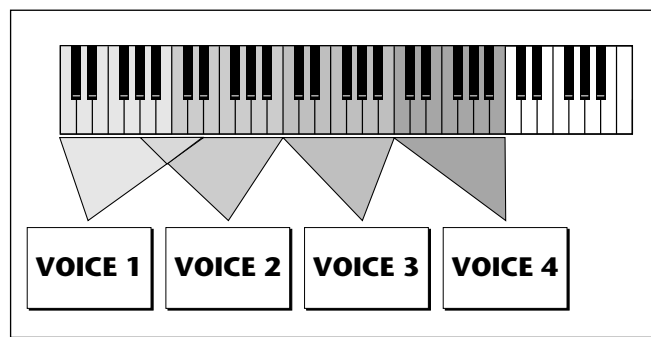

Voices - Velocity Window

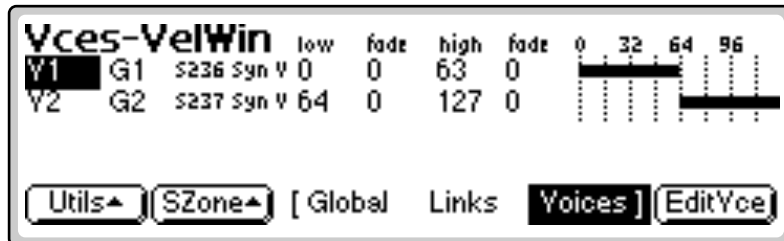

The Velocity Window of the Voices screen is accessed by pressing the Next Page key on the front panel from the Voices - Key Window screen. A screen similar to the one shown above appears. In the screen above, the two voices will be “velocity-switched” at a key velocity of 64. At key velocities below 64, voice 1 will play; at key velocities of 64 and above, voice 2 will play.

Velocity Window Controls

Voice Field: The voice can be selected using the numeric keypad or Data Entry Control.

Group Field: The group number of the voice can be changed using the numeric keypad or Data Entry Control.

Sample Name & Number: The voice's sample(s) can be changed from this window using the Data Entry Control or INC/DEC keys.

Velocity Controls: These controls set the high and low velocity range and the crossfade range for each voice and sample.

Graphic Display: Shows the velocity ranges of each voice and sample.

Utilities: New, Copy, Delete, and Split.

Sample Zone: New Sample Zone, Get Multisample, Delete Sample Zone, Combine and Expand.

Edit: Voice Selection & Dynamic Processing parameters.

Velocity Range

The Velocity Range screen allows you to control the volume of a voice by the key velocity. Using this function, you can crossfade or cross-switch between voices by key velocity. Suppose you had several samples (voices) of the same piano note, one played soft, the next played medium hard, and the third played hard. Using this function, you could set the velocity at which each of the voices would sound, thus recreating the response of the actual instrument.

To Velocity Switch Voices:

1. Press the **Preset Edit** key. The LED illuminates and the main preset edit screen appears.
2. Press the **Voices** function key (F5) to select the voice edit page of the editor. The Voices function key will be highlighted.
3. Press the **Next Page** key. The Voices - Key Window appears.
4. Edit the **High** and **Low** Key Range of the voices so they overlap as shown in the screen below. In order to velocity switch voices, they must first be assigned to the same keyboard range.

 Remember to **SAVE** the bank to disk or export the preset or all your programming will be lost.

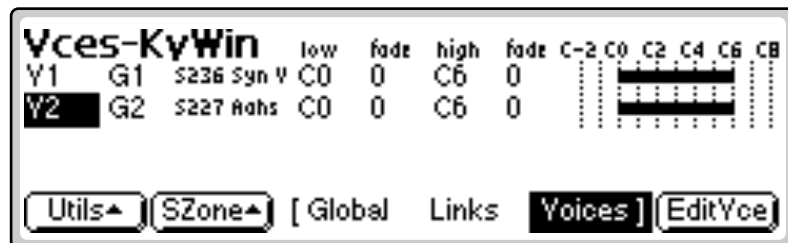

5. Press the **Next Page** key. The Voices - Velocity Window appears. The default velocity range is from 0-127 or full range. Both voices will sound regardless of what velocity is played.
6. **Set the velocity range of each voice** so that voice one sounds in the velocity range of 0-63, while voice two sounds in the velocity range of 64-127.

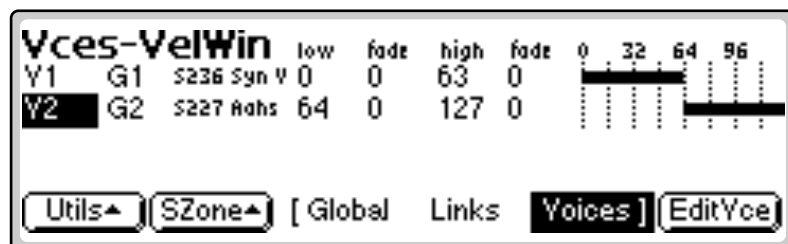

☞ **To Velocity Crossfade Voices:**

1. Press the **Preset Edit** key. The LED illuminates and the main preset edit screen appears.
2. Press the **Voices** function key (F5) to select the voice edit page of the editor. The Voices function key will be highlighted.
3. Press the **Next Page** key. The Voices - Key Window appears.
4. Edit the **High** and **Low** Key Range of the voices so they completely overlap each other. In order to velocity crossfade voices, they must first be assigned to the same keyboard range.
5. Press the **Next Page** key. The Voices - Velocity Window appears.
6. The default velocity range is from 0-127 or full range. **Set the velocity fades** so that voice one fades out the higher the key velocity, while voice 2 fades in, the higher the key velocity. At a velocity of 64, the two sounds will be equal volume. Adjust the fade-in and fade-out points to achieve a natural sounding crossfade. The actual crossfade points will vary depending on the sounds.

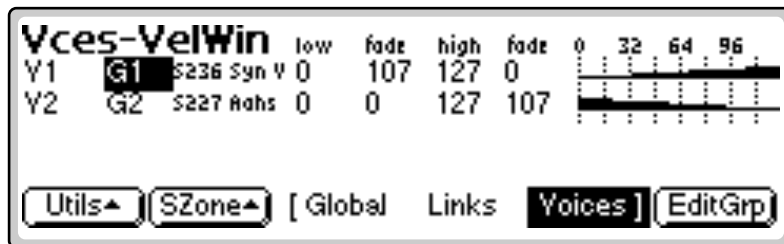

Voices - Realtime Window

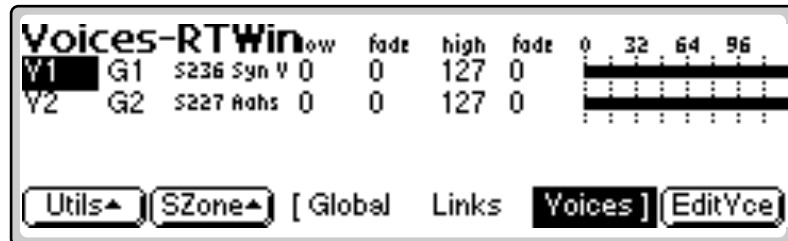

The Realtime Window lets you control the volume of any number of voices using a realtime controller such as a modulation wheel, a pedal or an LFO or Envelope Generator. It works in a manner very similar to the velocity window except that a realtime controller is used to control the crossfade instead of velocity.

The Realtime Window of the Voices screen is accessed by pressing the Next Page key on the front panel three times from the Main Voices screen.

Realtime Window Controls

Voice Field: The voice can be selected using the numeric keypad or Data Entry Control.

Group Field: The group number of the voice can be changed using the numeric keypad or Data Entry Control.

Sample Name & Number: The voice's sample(s) can be changed from this window using the Data Entry Control or INC/DEC keys.

Realtime Crossfade Controls: These controls set the high and low controller value range and the crossfade range for each voice and sample.

Graphic Display: Shows the realtime control ranges of each voice and sample.

Utilities: New, Copy, Delete, and Split.

Sample Zone: New Sample Zone, Get Multisample, Combine and Expand.

Edit: Voice Selection & Dynamic Processing parameters.



Realtime Crossfading is one of the more "advanced" applications of the machine. Make sure you understand how to select voices and assign cords before attempting to perform realtime crossfades.

To Realtime Crossfade Voices:

1. Press the **Preset Edit** key. The LED illuminates and the main preset edit screen appears.
2. Press the **Voices** function key (F5) to select the voice edit page of the editor. The Voices function key will be highlighted.
3. Press the **Next Page** key. The Voices - Key Window appears.
4. Edit the **High** and **Low** Key Range of the voices so they completely overlap each other. In order to velocity crossfade voices, they must first be assigned to the same keyboard range.
5. Press the **Next Page** key **twice**. The Voices - Realtime Window appears.
6. **Set the realtime range of each voice.** The next screen shows the realtime ranges set so that voice one will begin fading in after the realtime controller reaches a value of 32. Voice two will begin fading out when the realtime control reaches 32 and fades completely out by a value of 80.

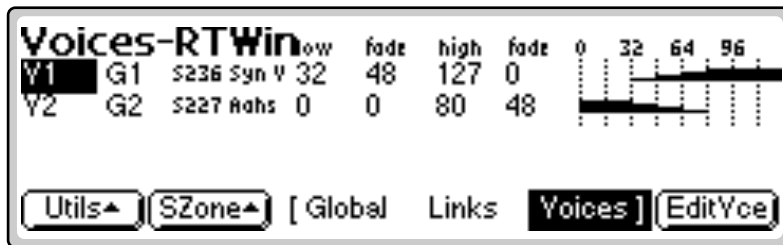

7. So far so good, but this is a Realtime Range. We have to assign a realtime Controller to control the crossfade. **Press EditVce** to enter the Dynamic Processing level.
8. Press the **Utils** function key (F1).
9. Press the **VSelect** function key (F2) to bring up the voice selection screen.
10. **Select all voices** you wish to realtime crossfade. Press OK.
11. Press the **Cords** function key (F5). The patchcord assign screen appears.
12. **Assign one of the realtime control sources** such as the mod wheel or an LFO to AmpXfd. Turn up the Amount parameter to 100%. You should be able to hear the crossfade.
13. Adjust the **crossfade ranges** and the **AmpXfd** amount until the crossfade responds correctly.

In certain situations, such as setting up drum kits, you may want to randomly switch between several voices. Crossfade Random is a modulation source specifically designed to handle this situation. Unlike the other random sources, Crossfade Random generates one random number for all voices that are assigned to the same key.

To Randomly Cross-Switch Between Voices:

1. Press the **Preset Edit** key. The LED illuminates and the main preset edit screen appears.
2. Press the **Voices** function key (F5) to select the voice edit page of the editor. The Voices function key will be highlighted.
3. Press the **Next Page** key. The Voices - Key Window appears.
4. Edit the **High** and **Low** Key Range of the voices so they completely overlap each other. In order to randomly crossfade voices, they must first be assigned to the same keyboard range.
5. Press the **Next Page** key **twice**. The Voices - Realtime Window appears.
6. **Set the realtime range of each voice.** The next screen shows the realtime ranges set so that voice 1 will sound whenever the random value is from 0 to 64. Voice 2 will sound whenever the random value is greater than 64.

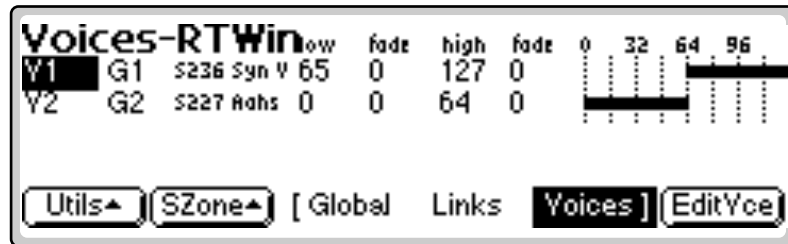

To Randomly Cross-Switch Between Voices:

7. Now you have to assign a realtime Controller to control the cross-switch. Press **EditVce** to enter the Dynamic Processing level.
8. Press the **Utils** function key (F1) and then the **VSelect** function key (F1) to bring up the voice selection screen.
9. **Select all voices** you wish to realtime crossfade.
10. Press **OK**.
11. Press the **Cords** function key (F5). The patchcord assign screen appears.
12. Assign **XfdRnd** to **AmpXfd**.
13. Set the **Amount** to 100%.

Preset Edit - Dynamic Processing Level

The Dynamic Processing level contains the traditional synthesizer controls such as envelope shaping of amplitude and filters as well as modulation parameters. Multiple voices can be selected in this level, unlike in Preset Definition where only one voice can be selected or edited at a time.

The dynamic processing parameters are accessed by pressing the Edit function key while in one of the Voice screens (or directly via an assignable key). Multiple voice selection is supported in any of the dynamic processing editing screens using a MIDI keyboard.

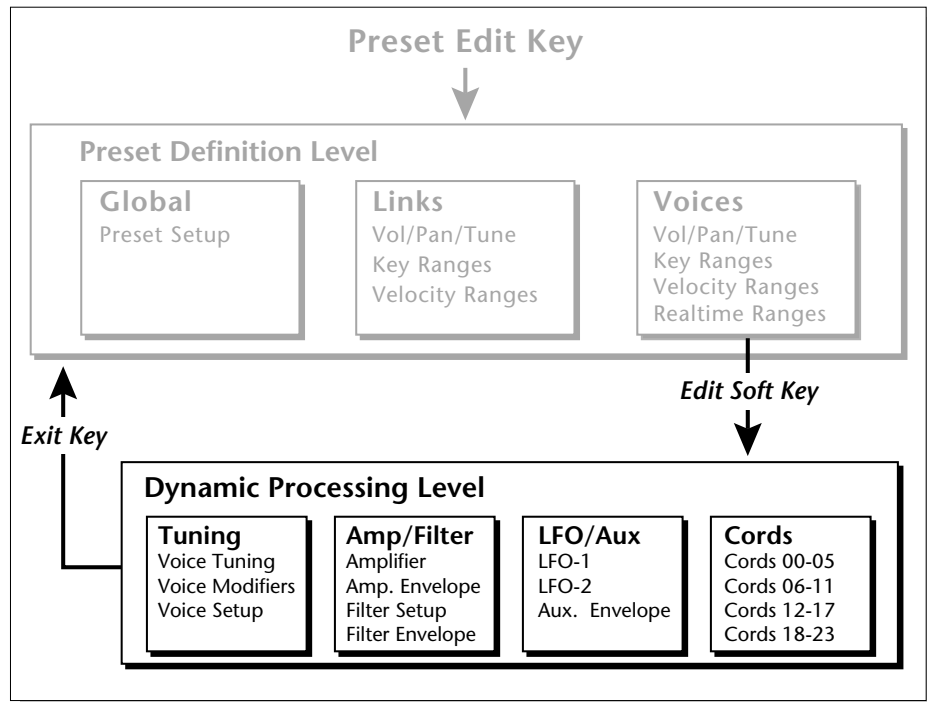

The signal path is actually very simple. You have one or more samples, a dynamically controlled filter, and a dynamically controlled amplifier with a panning network. Modulation parameters operate simultaneously on all samples contained in a voice.

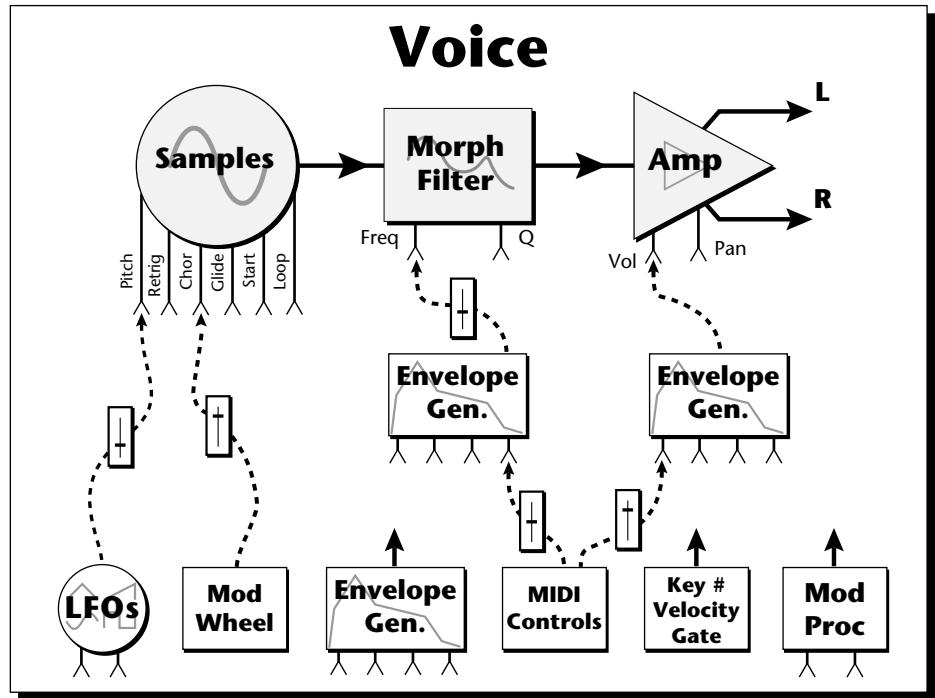

 When several samples are simultaneously sounding, each one goes through its own filter and amplifier, even though the voice modulation parameters are the same.

Each voice can have its own complete set of synthesizer parameters and modulation routings, or you can select a range of keyboard and edit any parameters you wish for that range. This voice system is very flexible because you can work with multisampled voices or single sample voices.

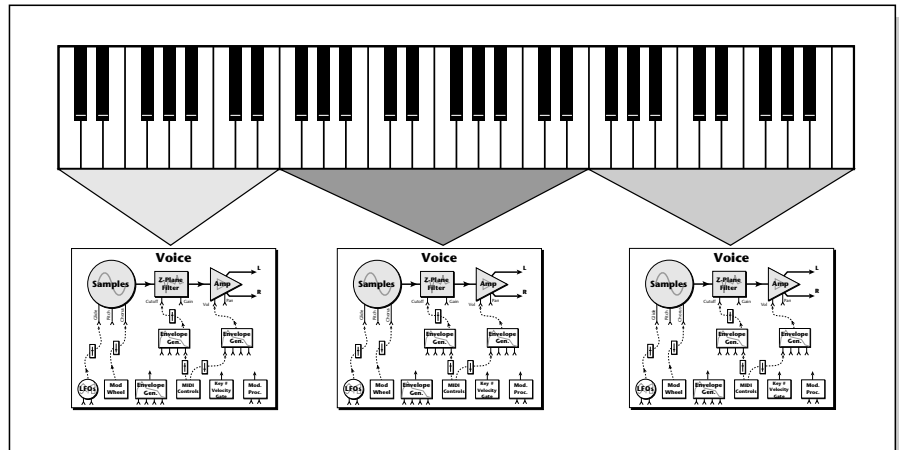

Voices Assigned to the Keyboard

8 - Preset Edit
Preset Edit - Dynamic Processing Level

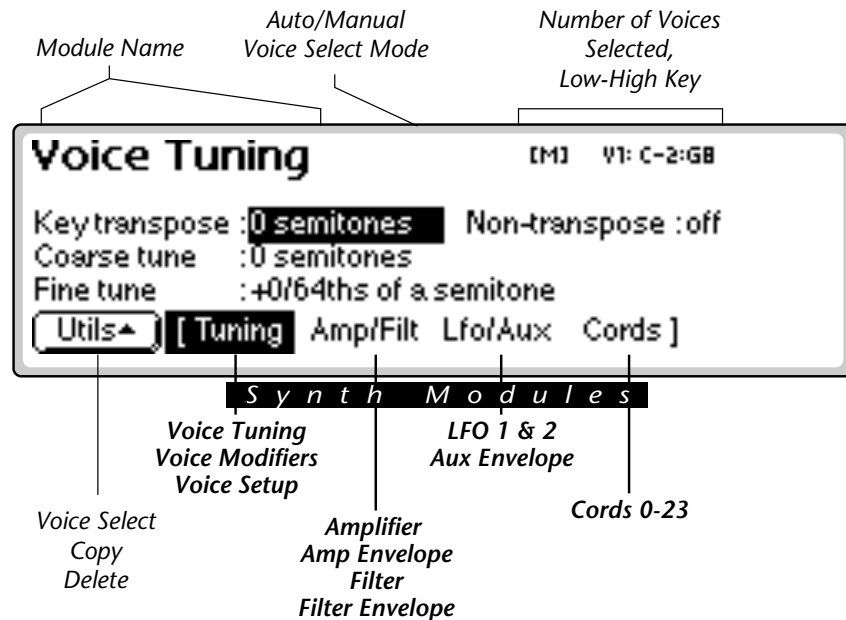

The screen shown above is part of the Dynamic Processing level of the Preset Editor. The page name is shown in the upper left hand corner. The small [M] indicates that voice selection is in Manual Mode. A small diamond ♦ appears next to the Auto/Manual indicator if the range you selected on the keyboard does not correspond with the actual boundaries of the selected voices.

The number of selected voices and the low and high key of the voice range is indicated by the top right line of the display. The lower left function key enables the Utilities menu. There are also four toggling function keys which select the synthesizer modules.

Tuning: Contains parameters which control the samples such as Transpose, Tuning, Nontranspose, Chorus, Delay, Start Offset, Glide, and Assign mode.

Amp/Filter: Controls the Dynamic Filter and Amplifier including their dedicated six-part envelopes.

LFO/Aux: Controls two low frequency oscillators and an auxiliary six-part envelope.

Cords: Contains the 24 assignable patchcords which connect everything together.

 *The last selected screen in each of the four submodules is automatically remembered.*

Utilities



The Utilities function in the Dynamic Processing level of the Preset Edit module contains the voice selection functions as well as utilities that allow you to perform operations on multiple voices at a time.

Pressing the **Utils** function key (F1) from the Dynamic Processing level enables a second row of function keys.

Voice Select: Invokes a graphic keyboard display with controls which provide you various ways of selecting voices.

Copy Voice(s): Allows you to copy a group of selected voices to another preset.

Delete Voice(s): Allows you to delete a group of selected voices from the preset.

Manual/Auto: Toggles between Automatic and Manual voice selection modes (without having to go into the Voice Selection screen).

Set: This function allows you to isolate a range of the keyboard and create a new voice from just that range.

Solo Voice: This function allows you to hear only the currently selected voice.

Voice Select

You might want to process one voice, one group, several voices, or the entire keyboard. This important function allows you to select which voice or voices will be processed by the dynamic processing parameters. If there is only one group in the preset, the group selection field will be faded out, indicating that it cannot be selected. Set a specific group number (rather than “all”) to select voices from a specific group.

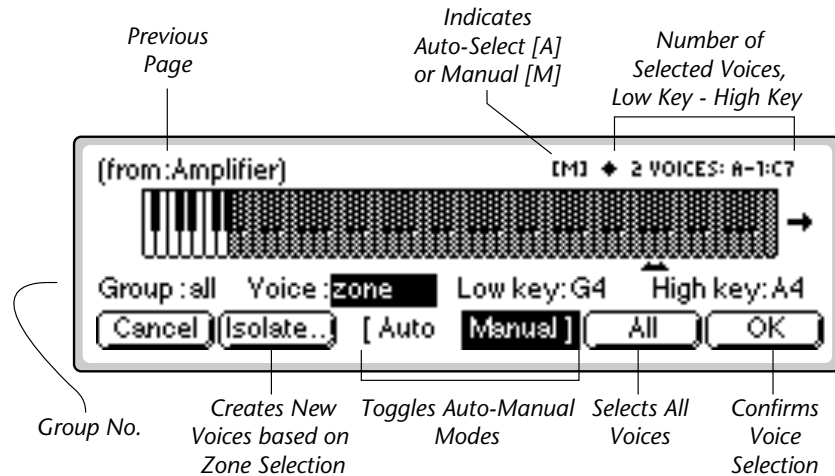

Function Keys

- **Cancel:** Cancels the new voice selection.
- **Isolate:** Automatically creates new voices based on new zone selection.
- **Auto/Manual:** Toggles between Auto/Manual voice select modes. See Automatic Voice Selection.
- **All:** Selects all voices in the preset.
- **OK:** Confirms the new voice selection.

The Voice field contains several selections.

- **All:** Selects all voices in the group.
- **Zone:** This type of selection allows you to select any arbitrary range by selecting low and high keys on the keyboard. The zone range can also be selected by moving the cursor to the low and high key fields and selecting low and high keys with the Data Entry Control. Zone will be automatically selected if you play two different keys on the keyboard.

Pressing the **Isolate** function key creates a new voice based on the zone selection. Pressing OK after defining a new zone, you will be asked if you wish to “Create new voices based on selection range?”. If you selected a subset of the current voice range, the voice will be split if you answer Yes. If you extend the range of the current voice, the range will be extended by answering Yes. Answering No selects the voices without changing them.

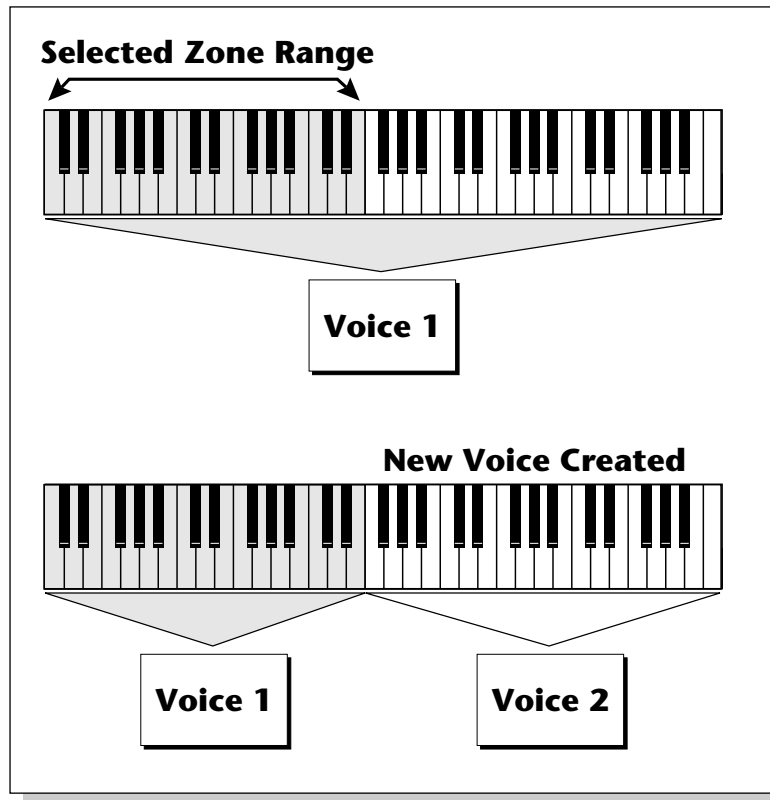

- **Includes:** If you play a single note the keyboard twice, the voice field will change to “includes”, and the graphic display indicates the entire range of the voice or voices in which that key is included. The number of voices selected is shown in the upper right corner of the display.
- **Number:** allows you to pick out single voices using the INC/DEC keys or the Data Entry Control.

To Select a Voice:

1. Press the **Preset Edit** key. The LED illuminates and the main preset edit screen appears.
2. Press the **Voices** function key (F5) to select the voice edit page of the editor. The Voices function key will be highlighted.
3. Press the **Edit** function key (F6). The most recently selected Preset Edit screen appears.
4. Press the **Utils** function key (F1). Another row of function keys appears.
5. Press the **VSelect** function key (F1). The Voice Select screen appears.
6. **Select the group** containing the voices you wish to process. If there is only one group, the group field will be faded out, indicating that it cannot be selected. If the voices you want are not grouped, go on to the next step.

7. **Select the voices** you wish to process by playing a note on the keyboard or by selecting the voice number for the “Voice” field.
 - Playing a single note on the keyboard changes the voice selector field to “includes” and the voice range you have selected will be darkened on the keyboard display. The upper right corner of the display shows the number of voices you have selected.
 - Playing two different notes on the keyboard changes the voice selector field to “zone”. The voice range you have selected will be shown by the range bar below the display. If you press OK a pop up window will ask you if you want to create a new voice from the selected range. Choosing Yes creates a new voice. Choosing No simply selects the included voices.
8. Press **OK** to confirm the selected voice(s) or **Cancel** to cancel the operation.

The Isolate Key:

Use this key when you want to make a new voice from a section of another voice in order to separately process it.

To Isolate a Key

1. In the voice selection screen, set the **Voice** parameter to **Zone**.
2. Move the cursor and set the **Low** and **High** keys of the new voice range using the Data Entry Control, INC/DEC keys or the keyboard.
3. Press the **Isolate** function key (F2). A new voice will instantly be created.
4. **Select the new voice** and process it.

Copy Voice(s)

In the Preset Definition level, only one voice can be selected and copied at a time. In this layer, the Dynamic Processing level, multiple voices can be selected. This copy function is different in that it allows multiple voices to be copied and pasted.

To Copy Multiple Voices:

1. Press the **Preset Edit** key. The LED illuminates and the main preset edit screen appears.
2. Press the **Voices** function key (F5) to select the voice edit pages of the editor. The Voices function key will be highlighted.
3. Press the **Edit** function key (F6) to select the dynamic processing level of the editor.

 For more information about Groups, see Background: Groups, at the beginning of this section.

4. Press the **Utils** function key (F1) and then **VSelect** (F1).
5. **Select the voices** you wish to copy, then press **OK**.
6. Press the **Utils** function key (F1).
7. Press the **Copy...** function key (F3).

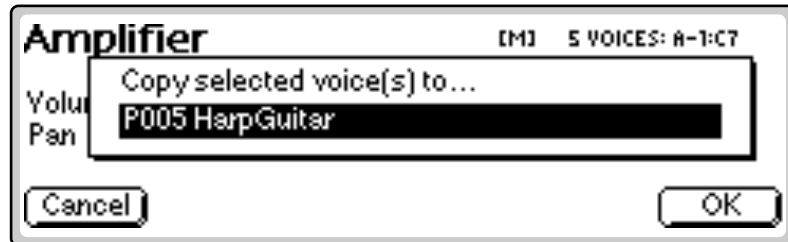

8. **Select the destination preset** using the Data Entry Control, the **INC/DEC** keys, or the numeric keypad. Press **OK** when you have selected the destination preset or **Cancel** to cancel the operation. The following screen appears.



9. **Enter the starting key** where the copied voices will be placed using the Data Entry Control, the **INC/DEC** keys or your MIDI keyboard. You also have the option to offset the group number of the copied voices. This feature can be used to keep the copied voices separate from voices already in the preset.
10. Press **OK** to copy the voices or **Cancel** to cancel the operation.
11. If you copied the voice(s) to a empty preset, you will be asked to name the new preset.

8 - Preset Edit Delete Voice(s)

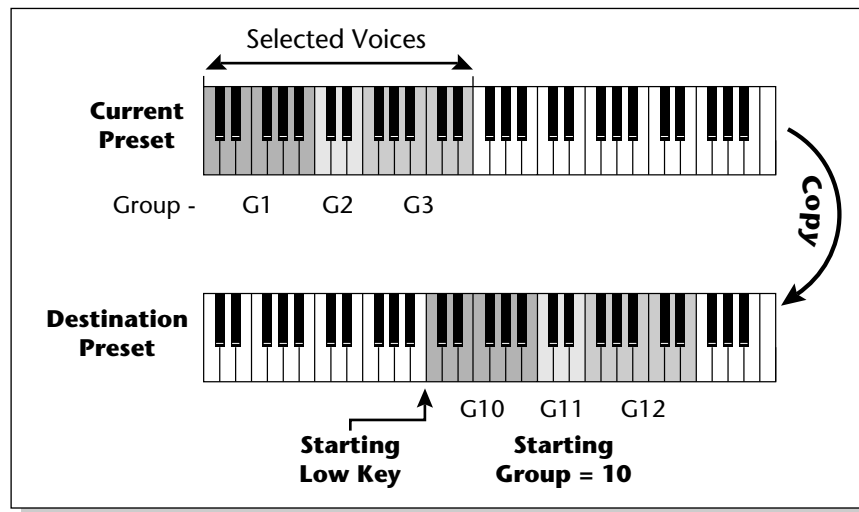

Copied voices can be placed in the destination preset starting at any key number and starting at any group number.

Delete Voice(s)

Multiple voices can be deleted at a time using this function. The samples contained within the voices are not deleted.

To Delete Multiple Voices:

1. Press the **Preset Edit** key. The LED illuminates and the main preset edit screen appears.
2. Press the **Voices** function key (F5) to select the voice edit page of the editor. The Voices function key will be highlighted.
3. Press the **Edit** function key (F6) to select the dynamic processing level of the editor.
4. Press the **Utils** function key (F1) and then VSelect (F1).
5. **Select the voices** you wish to delete, then press OK.
6. Press the **Utils** function key (F1). A pop up window appears asking you if you really do want to erase the selected voices.
7. Press **OK** to delete the selected voices or **Cancel** to cancel the operation.

Automatic Voice Selection

Voices within the currently selected group (or All) may also be selected directly from any voice edit screen without having to go back to the voice select screen.

To Select a Voice using the Auto Select feature:

1. From the Voice Selection screen (Preset Edit, Edit Voice, Utils, VSelect), press **Auto** (F3).
2. **Select a group number** (if desired) from the voice selection screen. Auto Select will only select voices from the group you choose (group number or all).
3. Press **OK** to exit voice selection.
4. Voices will now be selected by playing the keyboard in any voice edit screen (Tuning, Amp/Filt, LFO/Aux, Cords).
5. Selecting a single note will select all voices assigned to that key.
6. Selecting a keyboard range by pressing two notes at once will select all voices within that range.

WARNING!

Be careful when selecting a range of voices using Auto Select! When you play the keyboard to hear the results of your edit, you are changing the voice selection range. Be sure to re-key the voice selection range before resuming your editing.

Set

This button performs the same function as the Isolate key in the Voice Selection screen. If the selected key range does not exactly match the voice ranges, you will be asked if you want to isolate new voices from the existing range. Pressing Yes creates a new voice or voices based on your selected range. Pressing No simply selects the included voices.

Solo Voice

When Solo Voice is activated only the currently selected voice will be heard. **The voice number will be flashing** to remind you that the voice is soloed. Solo voice works both in the Preset Definition level and the Dynamic Processing level of the Preset Editor.

See "Solo Voice" on page 307.

Voice Tuning, Modifiers & Setup

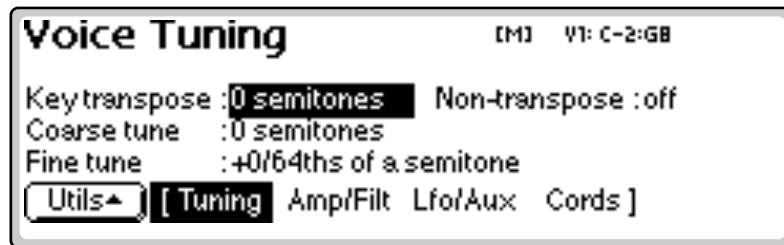

The voice contains several tuning and setup parameters.

- Key Transpose
- Coarse Tuning
- Fine Tuning
- Non-Transpose Mode
- Chorus Parameters
- Delay
- Start Offset
- Glide Parameters
- Solo Modes
- Assignment Group
- Latch Mode

 *Transpose, coarse tune, and fine tune can also be edited at the preset definition level in the Voices-Main screen.*

Key Transpose

This function allows you to transpose the key of the selected voice(s) in semitone intervals by shifting the keyboard position relative to middle C. The transpose range is -24 to +24 semitones. You will normally use the transpose function to tune a voice to its keyboard location, or simply to transpose the voice.

To Transpose a Voice:

1. From the Dynamic Processing level of the Preset Editor, **select the voice(s)** you wish to transpose using the voice selection screen.
2. Press the **Tuning** function key (F2).
3. Use the Previous and Next Page keys to locate the **Voice Tuning** screen shown on the previous page.
4. Select **Key Transpose** using the cursor keys.
5. **Change the transpose parameter** to the desired amount using the Data Entry Control or the INC/DEC keys.
6. Press the **Exit** key to return to the Preset Definition level of the Preset Editor or press any of the dynamic processing function keys to move to another module.



Use Transpose when you want the voice's timbre to remain constant.

Use Coarse Tuning when you want to change the timbre of the voice.



Use the Coarse Tuning control to change the tuning of voices containing multiple drums.

Coarse Tuning

This function allows you to change the tuning of the voice in semitone intervals. The coarse tuning range is -72 to +24 semitones. Unlike the transpose function, coarse tuning stretches the pitch of the individual samples assigned to a key and may change the timbre of a voice.

To Coarse Tune a Voice:

1. From the Dynamic Processing level of the Preset Editor, **select the voice(s)** you wish to coarse tune using the voice selection screen, then press the Tuning function key (F2).
2. Use the Previous and Next Page keys to locate the **Voice Tuning** screen.
3. Select **Coarse Tune** using the cursor keys.
4. **Change the Coarse Tuning parameter** to the desired amount using the Data Entry Control or the INC/DEC keys.
5. Press the **Exit** key to return to the Preset Definition level of the Preset Editor or press any of the dynamic processing function keys to move to another module.

Fine Tuning

This function allows you to change the tuning of the voice in 1/64 semitone intervals (approx. 1.56 cents). The fine tuning range is ± 1 semitone. Fine tuning can be used to slightly detune a voice, creating a “fatter” sound when it is combined with another voice.

To Fine Tune a Voice:

1. From the Dynamic Processing level of the Preset Editor, **select the voice(s)** you wish to fine tune using the voice selection screen, then press the Tuning function key (F2).
2. Use the Previous and Next Page keys to locate the **Voice Tuning** screen.
3. Select **Fine Tuning** using the cursor keys.
4. Adjust the **Fine Tuning** parameter to the desired amount using the Data Entry Control or the INC/DEC keys.
5. Press the **Exit** key to return to the Preset Definition level of the Preset Editor or press any of the dynamic processing function keys to move to another module.

Non-transpose Mode

This function turns keyboard transposition On or Off for the voice. With Nontranspose On, the keyboard will not control the pitch of the voice. This is a useful function for drones or “chiffs”, which you may not want to track the keyboard.

To Set a Voice to Non-Transpose:

1. From the Dynamic Processing level of the Preset Editor, **select the voice(s)** you wish to put in non-transpose mode using the voice selection screen, then press the Tuning function key (F2).
2. Use the Previous and Next Page keys to locate the **Voice Tuning** screen.
3. Select **Nontranspose** using the cursor keys.
4. Turn **Non-transpose** On or Off using the Data Entry Control or the INC/DEC keys.
5. Press the **Exit** key to return to the Preset Definition level of the Preset Editor or press any of the dynamic processing function keys to move to another module.

Chorus Amount

Chorus “thickens” the sound by doubling the sound in stereo and then detuning it.

 **Tip #1.** Set chorus amount to 1% and use chorus width as a pan control which does not span the entire L/R spread.

 **Tip #2.** To avoid L/R pitch drift, use “~” type of modulation in the cords menu.

 **Tip #3.** Set the Chorus Width to 0% and adjust the ITD to create a through-zero flange effect. With 100% width, a panning chorus effect is obtained.

 **Tip #4.** Modulate the ITD to create “Hass-Effect Panning”.

 **Tip #5.** For a detuned analog oscillator sound, set stereo width to 100%. Route a free running LFO (~) to chorus position with the amount set to about 25%.

Amount: is the amount of detuning and is variable from Off to 100%.

Stereo Width: controls the stereo spread. 0% reduces the chorus to mono and 100% gives the most stereo separation.

Inter-Aural Time Delay (ITD): adjusts the delay of the left and right sounds. Positive values start the right channel early and the left late.

Chorus amount and ITD can be modulated in the Cords screen, although ITD can only be changed at the time of the key depression. When Chorus is on, a mono voice will use twice as many channels. Set the chorus width to 0% and adjust the ITD to create a through-zero flange effect. With 100% width, a panning-chorus effect is obtained.

To Chorus a Voice:

1. From the Dynamic Processing level of the Preset Editor, **select the voice(s)** you want to chorus using the voice selection screen, then press the Tuning function key (F2).



2. Use the Previous and Next Page keys to locate the **Voice Modifiers** screen shown above.
3. Select Chorus **Amount** using the cursor keys. Adjust using the Data Entry Control or INC/DEC keys.
4. Select the Chorus **Stereo Width** using the cursor keys. Adjust using the Data Entry Control or INC/DEC keys.
5. Select **Inter-Aural Time Delay** using the cursor keys. Adjust using the Data Entry Control or INC/DEC keys.
6. Press the **Exit** key to return to the Preset Definition level of the Preset Editor or press any of the dynamic processing function keys to move to another module.

Delay

Delay varies the time between the arrival of a MIDI Note-On message and the onset of a note. The delay time is adjustable from 0 to 10,000 milliseconds (0-10 seconds). Delay can be used to create echo effects or to thicken the sound when using layered voices.

To Delay a Voice:

1. From the Dynamic Processing level of the Preset Editor, **select the voice(s)** you wish to delay using the voice selection screen, then press the Tuning function key (F2).
2. Use the Previous and Next Page keys to locate the **Voice Modifiers** screen.
3. Select **Delay** using the cursor keys.
4. Set the **Delay Time** using the Data Entry Control or the INC/DEC keys.
5. Press the **Exit** key to return to the Preset Definition level of the Preset Editor or press any of the dynamic processing function keys to move to another module.

Start Offset

This function allows you to set where the voice's sample begins playing when you hit a key. A setting of 0 plays a sample from the beginning, higher values move the sample start point toward the end of the sound.

To Offset the Samples in a Voice:

1. From the Dynamic Processing level of the Preset Editor, **select the voice(s)** you wish to process using the voice selection screen, then press the Tuning function key (F2).
2. Use Previous and Next Page keys to locate the **Voice Modifiers** screen.
3. Select **Start Offset** using the cursor keys.
4. Adjust the **Start Offset** using the Data Entry Control or INC/DEC keys.
5. Press the **Exit** key to return to the Preset Definition level of the Preset Editor or press any of the dynamic processing function keys to move to another module.

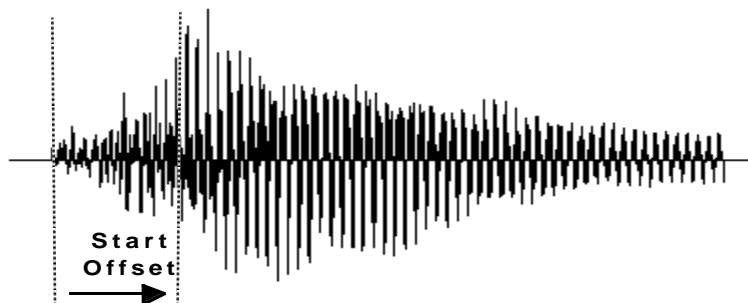

Glide Rate & Curve

Glide is a smooth gliding between notes instead of the normal instantaneous change in pitch when a new key is pressed. The glide rate determines the time it takes to glide to the new pitch. The larger the value, the slower the glide rate. The rate is adjustable from 0 to 32.738 seconds. Zero seconds equals Off. A glide curve setting of 0 equals linear. Higher values make the curve more exponential. Glide is polyphonic, but can be monophonic when in Solo mode.

To Change the Glide Rate of a Voice:

1. From the Dynamic Processing level of the Preset Editor, **select the voice(s)** you wish to glide using the voice selection screen, then press the Tuning function key (F2).
2. Use the Previous and Next Page keys to locate the **Voice Setup** screen shown below.



3. Select **Glide Rate** using the cursor keys.
4. Adjust the **Rate of Glide** using the Data Entry Control or the INC/DEC keys.
5. Select **Glide Curve** using the cursor keys.
6. Select the **Curve** number using the Data Entry Control or the INC/DEC keys.
7. Press the **Exit** key to return to the Preset Definition level of the Preset Editor or press any of the dynamic processing function keys to move to another module.

Solo Modes

Solo mode provides the playing action of a monophonic instrument. It can make wind and string instruments sound more realistic by preventing more than one note from sounding at once. There are eight different solo modes provided which can be used with monophonic synthesizer sounds or to create other performance effects.

Multiple Trigger: Last note priority. No key-up action. Retrigger envelopes and samples when a key is pressed.

Melody (last): Last note priority. No key-up action.

- *First solo note:* Envelopes start at Attack segment from zero. Samples start at the beginning.
- *If previous note is releasing:* Envelopes start at Attack segment, but from current level. Samples start at the beginning.
- *When playing "Legato":* Envelopes continue from current segment and level. Samples start at the loop or the beginning if unlooped.

Melody (low): Same as Melody (last), but with low-note priority. Newly played keys which are higher than the lowest solo key held will not sound.

Melody (high): Same as Melody (last), but with high-note priority. Newly played keys which are lower than the highest solo key held will not sound.

Synth (last): Similar to Melody (last) with key-up action. When currently sounding solo key is released while still holding other keys, the highest held solo key sounds in a Legato fashion (envelopes not retriggered).

Synth (low): Same as Synth (last), but with low note priority. When the currently sounding solo key is released when other keys are still held, the lowest held solo key will sound in a Legato fashion. (MiniMoog).

• **Synth (high):** Same as Synth (last), but with high-note priority. When the currently sounding solo key is released when other keys are still held, the highest held solo key will sound in a Legato fashion.

Fingered Glide: Same as Synth (last), except that Glide is disabled when playing Staccato, enabled when playing Legato.

To Put a Voice into Solo Mode:

1. From the Dynamic Processing level of the Preset Editor, **select the voice(s)** you wish to place in solo mode using the voice selection screen, then press Tuning (F2).
2. Use the Previous and Next Page keys to locate the **Voice Setup** screen.
3. Select **Solo Mode** using the cursor keys.

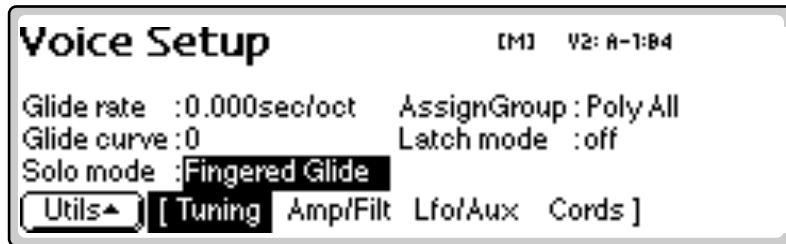

4. Select one of the **Solo Modes** using the Data Entry Control or the INC/DEC keys.
5. Press the **Exit** key to return to the Preset Definition level of the Preset Editor or press any of the dynamic processing function keys to move to another module.

Latch Mode

When Latch mode is On, pressing a key once will latch the key on. Pressing the key again will unlatch the key. This mode was originally designed for doing sound effects work, but you can probably find many other uses for it, such as latching sampled grooves. Any voices assigned to the same key as a latched voice will also latch.

To Put a Voice into Latch Mode

1. From the Dynamic Processing level of the Preset Editor, **select the voice(s)** you want to place in solo mode using the voice selection screen, then press the **Tuning** function key (F2).
2. Use the **Previous** and **Next Page** buttons to locate the **Voice Setup** screen.
3. Select **Latch Mode** using the cursor buttons.
4. Press the **Exit** button to return to the Preset Definition level of the Preset Editor or press any of the dynamic processing function keys to move to another module.



Using Latch Modes together with the Solo Modes may cause unpredictable results.

Assign Group

This function allows you to assign a certain number of output channels to each voice. By assigning all voices in the preset to assign groups, important parts can be protected from being “stolen” by more recently played keys. Or, a voice such as an open high hat can be assigned to a mono channel so it will be cancelled by a closed high hat. Voices will rotate within their assigned bin of channels not interfering with other bins. Poly All is the default mode.

The modes are as follows.

- **Poly All:** Notes are played polyphonically with dynamic channel assignment, using all 128 channels.
- **Poly 16 A-B:** Two bins of 16 channels each. Notes are played polyphonically with dynamic channel assignment, but using no more than 16 channels.
- **Poly 8 A-D:** Four bins of 8 channels each. Notes are played polyphonically with dynamic channel assignment, but using no more than 8 channels.
- **Poly 4 A-D:** Four bins of 4 channels each. Notes are played polyphonically with dynamic channel assignment, but using no more than 4 channels.
- **Poly 2 A-D:** Four bins of 2 channels each. Notes are played polyphonically with dynamic channel assignment, but using no more than 2 channels.
- **Mono A-I:** Nine monophonic channels. Any voices assigned to the same letter interrupt each other, but does not affect other voices.

To Assign Voices to a Group:

1. From the Dynamic Processing level of the Preset Editor, **select the voice(s)** you wish to group using the voice selection screen.
2. Press the **Tuning** function key (F2).
3. Use the Previous and Next Page buttons to locate the **Voice Setup** screen.
4. Select **Assign Group** using the cursor buttons.
5. Select the type of **Assign Group** using the Data Entry Control or the INC/DEC buttons.
6. Press the **Exit** button to return to the Preset Definition level of the Preset Editor or press any of the dynamic processing function keys to move to another module.

Amplifier/Filter



Amplifier Parameters

These parameters set the overall volume and pan settings, as well as the output channels for the selected voice(s).

Volume: Sets the initial volume of the voice. Variable from -96 dB (off) to +10 dB. The default setting is 0 dB which allows a bit of headroom so that other modulators can be added in without clipping. Use this volume control to balance the voice output against others. If you hear clipping, reduce volume setting.

Pan: Sets the initial stereo pan position of the voice. Subsequent modulation is added to or subtracted from this value.

Amp Envelope Depth: Sets the maximum amount of attenuation from the amplifier envelope generator. Variable from -96 dB to -48 dB. With longer attack times, reducing the envelope depth (towards -48 dB) has the perceived effect of providing a more natural volume envelope.

Submix: Allows you to route the selected voice(s) to a pair of output channels.

 **Note:** The submix outputs incorporate an automatic "plug-sensing" scheme which ignores submix routings if plugs are not inserted into the appropriate submix output jacks.

To Set the Amplifier Parameters:

1. From the Dynamic Processing level of the Preset Editor, **select the voice(s)** you wish to process using the voice selection screen, then press the Amp/Filt function key (F3).
2. Use the Previous and Next Page buttons to locate the **Amplifier** screen.
3. Adjust the **Amplifier** parameters as desired.
4. Press the **Exit** button to return to the Preset Definition level of the Preset Editor or press any of the dynamic processing function keys to move to another module.

Amplifier Envelope

The amplifier envelope generator is permanently connected to control the dynamic amplifier although it can also be patched to control any other modulation destination.

- The way the volume of a sound changes over time determines how we perceive that sound. A bell struck with a hammer is instantly at full volume, then slowly dies away. A bowed violin sound fades in more slowly and dies away slowly. Using the amplifier envelope, you can simulate different types of instrument volume envelopes.

 The envelope rates can be modulated by any controller in the Cords page.

Attack Rates, Decay Rates, Release Rates or All Rates can be modulated.

To Set the Amplifier Envelope:

1. From the Dynamic Processing level of the Preset Editor, **select the voice(s)** you wish to process using the voice selection screen, then press the **Amp/Filt** function key (F3).

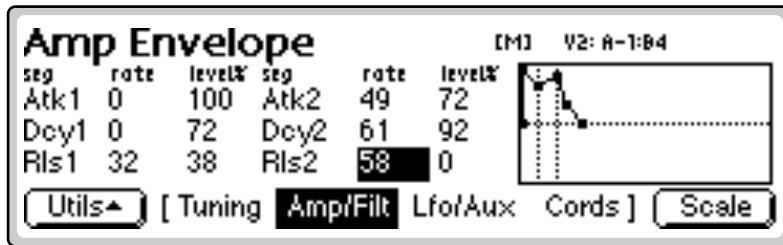

2. Use the **Previous** and **Next Page** buttons to locate the Amp Envelope screen.

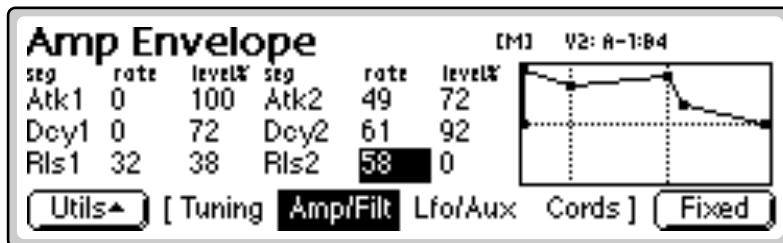

3. Press the **Scale** function key. The graphic display of the filter envelope changes from a “fixed-rate” display to a “time-scaled” display.
4. Select and adjust the **Amplifier Envelope** parameters. Use the cursor buttons to move the cursor around to the various parameters and the Data Entry Control or INC/DEC buttons to change the time and level of each stage.
5. Press the **Exit** button to return to the Preset Definition level of the Preset Editor or press any of the dynamic processing function keys to move to another module.

 Unlike the filter envelope generator, the amplifier envelope does not let you set negative levels.

Filter Parameters

A low pass filter allows only the low frequencies to pass and can be used to simulate many natural sounds since it is common in the physical world for the high frequencies to die away first as the sound decays. Set the frequency of a lowpass filter at maximum if you do not want any filtering action. The various filter types are described at the beginning of this chapter.

Filter Type: 21 filter types are currently implemented. Standard lowpass, bandpass, and highpass filters are included as well as swept parametrics, phasers, flangers, vocal formant filters and programmable morphing filters.

Frequency (Morph): Sets the initial frequency of the filter. In the case of a Morphing filter, this parameter sets the initial position between the two filters.

Resonance (Q, Gain, Resonance, Body Size): High values of Q amplify frequencies near the cutoff or center frequency.

In a swept EQ, Gain controls the amount of boost or cut. In a phaser or flanger, the resonance determines the depth of the effect.

In the vocal filters, Body Size determines the apparent size of the mouth cavity. Gain is a "Note-on" parameter, meaning that it is set at note-on time and cannot be continuously varied during the note.

FILTER TYPES

2-Pole Lowpass

Lowpass filter with 12dB/octave rolloff and Q control.

4-Pole Lowpass

Lowpass filter with 24dB/octave rolloff and Q control.

6-Pole Lowpass

Lowpass filter with 36 dB/octave rolloff and Q control.

2nd Order Highpass

Highpass filter with 12 dB/octave rolloff and Q control.

4th Order Highpass

Highpass filter with 24 dB/octave rolloff and Q control.

2nd Order Bandpass

Bandpass filter with 6 dB/octave rolloff on either side of the passband and Q control.

4th Order Bandpass

Bandpass filter with 12 dB/octave rolloff on either side of the passband and Q control.

Contrary Bandpass

A novel bandpass filter where the frequency peaks and dips cross midway in the frequency range.

Swept EQ, 1-octave

Parametric filter with 24 dB of boost or cut and a one octave bandwidth.

Swept EQ, 2->1-octave

Parametric filter with 24 dB of boost or cut. The bandwidth of the filter is two octaves wide at the low end of the audio spectrum, gradually changing to one octave wide at the upper end of the spectrum.

Swept EQ, 3->1-octave

Parametric filter with 24 dB of boost or cut. The bandwidth of the filter is three octaves wide at the low end of the audio spectrum, gradually changing to one octave wide at the upper end of the spectrum.

Phaser 1

Recreates a comb filter effect typical of phase shifters. Frequency moves position of notches. Resonance varies the depth of the notches.

Phaser 2

Comb filter with slightly different notch spacing than Phaser 1. Frequency moves position of notches. Resonance varies the depth of the notches.

Bat Phaser

Phase shift filter with peaks as well as notches.

Flanger Lite

Contains three notches. Frequency moves frequency and spacing of notches. Resonance increases flanging depth.

Vocal Ah-Ay-Ee

Vowel formant filter which sweeps from "Ah" sound, through "Ay" sound to "Ee" sound at maximum morph. Body size varies the apparent size of mouth cavity.

Vocal Oo-Ah

Vowel formant filter which sweeps from "Oo" sound, through "Oh" sound to "Ah" sound at maximum morph. Body size varies the size of mouth cavity.



Tip: The second filter parameter (resonance, Q, gain, body size, peak, expression) is controlled by the 'FilRes' parameter in the Cords screen.

Dual EQ Morph

This is a programmable 2-frame Morphing filter with two EQ sections. As the Morph value is increased, the filter interpolates from the low to high settings. The Gain of each section remains constant during the Morph, but can be scaled at note-on time by controlling the Initial Gain parameter. This filter can be used to create your own vocal formant filters.

2EQ + Lowpass Morph

This unusual filter has two EQ sections and a lowpass filter whose Fc is also controlled by the Morph parameter. The Lowpass filter is completely open at a setting of 255. As the Morph value is increased, the filter interpolates from the low to high settings and the lowpass filter allows more high frequencies to pass. The Q of the lowpass filter has an initial setting and can be also modulated at note-on time.

2EQ Morph + Expression

This filter also has two EQ sections and a lowpass filter with independent control over the lowpass filter frequency (Expression). This allows you to use velocity (for example) to control expressive timbre via the lowpass filter, while the Morph parameter is modulated for another effect. As the Morph value is increased, the filter interpolates from the low to high settings.

Peak/Shelf Morph

This 2-frame morphing filter offers independent control over frequency, shelving and peak for each of the two filter “frames”. The Peak parameter can also be scaled at note-on time by controlling the Initial Peak parameter.

When the Shelf parameter is negative, the filter will have a low shelving response. When the Shelf parameter is positive, the filter will assume a high shelving response. With Shelf at zero, the filter assumes a peak filter response.

- Note that the two frames of this filter are displayed from left to right unlike the frames of the other morphing filters which are displayed low to high.

To Set the Filter Parameters:

1. From the Dynamic Processing level of the Preset Editor, **select the voice(s)** you wish to process using the voice selection screen, then press the Amp/Filt function key (F3).
2. Use the **Previous** and **Next Page** buttons to locate the **Filter** screen.
3. Adjust the **Filter** parameters as desired. The filter envelope, the filter envelope amount (adjusted in the Cords screen), and the initial filter parameters all interact.
4. Press the **Exit** button to return to the Preset Definition level of the Preset Editor or press any of the dynamic processing function keys to move to another module.

 **Tip:** *The Morphing filters allow high resonance values without losing bass power.*

Examples of Morphing Filter Response Curves

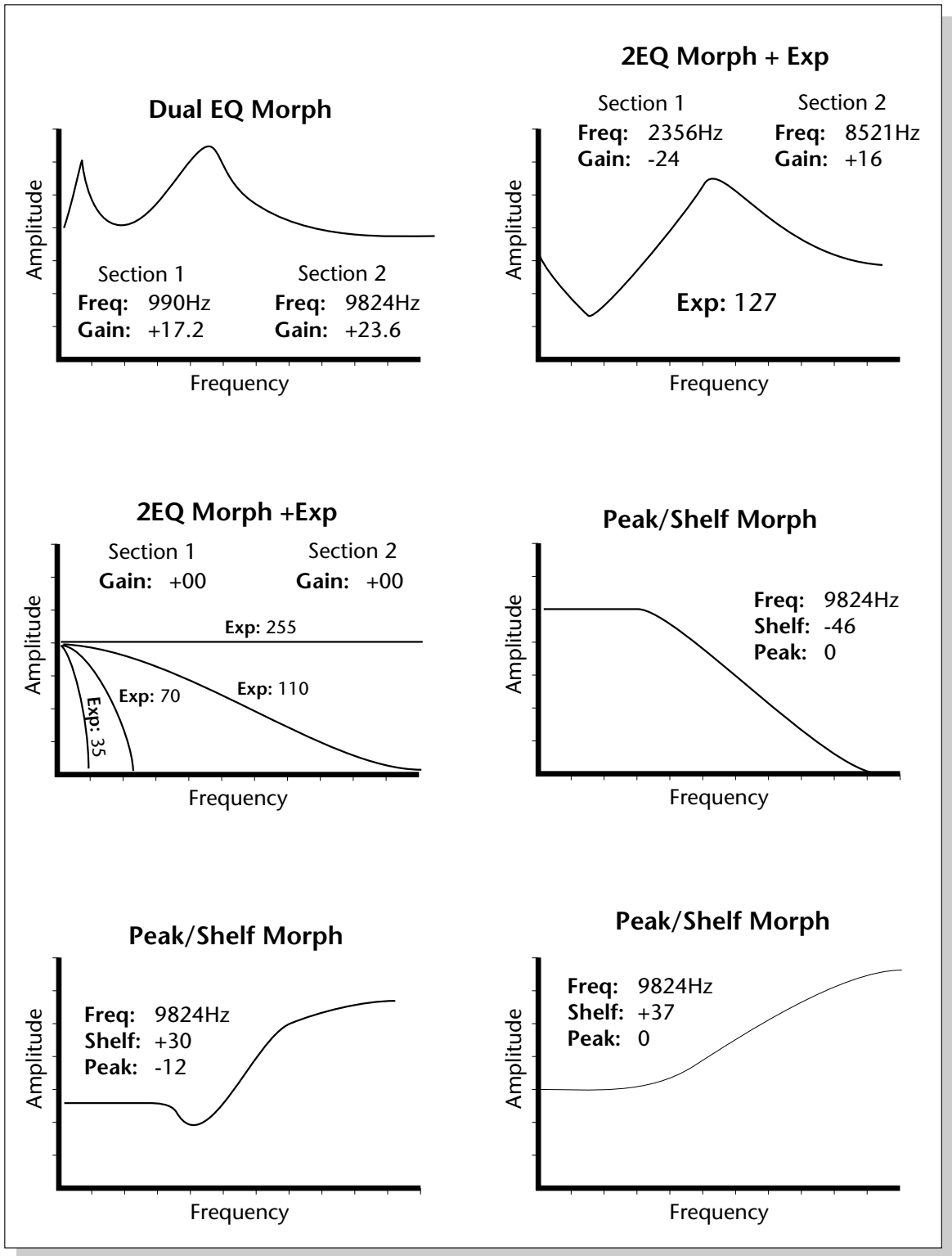

Filter Envelope

The Filter Envelope is usually assigned to control the filter cutoff parameter although it can be patched to any modulation destination.

To Set the Filter Envelope:

1. From the Dynamic Processing level of the Preset Editor, **select the voice(s)** you wish to process using the voice selection screen, then press the Amp/Filt function key (F3).
2. Use the **Previous** and **Next Page** buttons to locate the **Filter Envelope** screen.
3. Press the **Scale** function key. The graphic display of the filter envelope changes from a “fixed-rate” display to a “time-scaled” display. Use the display view that works best for the envelope you are using.

 For more information on the Filter Envelope see *Background: Programming Basics* at the beginning of this section.

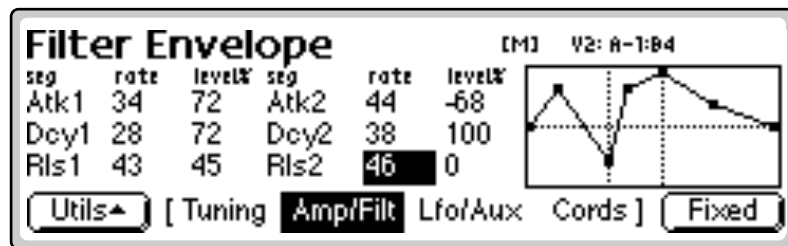

4. Select and adjust the **Filter Envelope** parameters. Use the cursor buttons to move the cursor around to the various parameters and the Data Entry Control or INC/DEC buttons to change the time and level of each stage.
 - The filter envelope allows you to set negative levels. When patched to the filter cutoff frequency, this useful feature allows the envelope to lower the cutoff frequency below the initial setting.
5. Press the **Exit** button to return to the Preset Definition level of the Preset Editor or press any of the dynamic processing function keys to move to another module.

LFO/Auxiliary Envelope

- **Delay:** Sets the amount of time between playing a key and the onset of modulation. This can be used to simulate an effect often used by acoustic instrument players, where the vibrato is brought in only after the initial note pitch has been established. The delay range is adjustable from 0 seconds to 20 seconds.
- **Shape:** Sets the LFO waveshape which determines the effect of the LFO. There are 16 LFO waveforms and a random, sample & hold type of wave which outputs random levels at the LFO rate. The LFO waveforms are diagrammed on the following page.
- **Variation:** Sets the amount of random variation on an LFO each time a key is pressed. This function is useful for ensemble effects, where each note played has a slightly different modulation rate. The higher the number, the greater the note to note variation in the LFOs.
- **Sync:** Key Sync or Free Running. With key sync selected the LFO wave starts at the beginning of its cycle at each key depression. In free run mode, the LFO wave begins at a random point in its cycle on each key depression.

To Program an LFO:

1. From the Dynamic Processing level of the Preset Editor, **select the voice(s)** you wish to process using the voice selection screen, then press the LFO/Aux function key (F4).
2. Use the **Previous** and **Next Page** buttons to locate the **LFO 1** or **LFO 2** screen.
3. Adjust the **LFO parameters** as desired.
4. Press the **Exit** button to return to the Preset Definition level of the Preset Editor or press any of the dynamic processing function keys to move to another module.

LFO Waveshapes

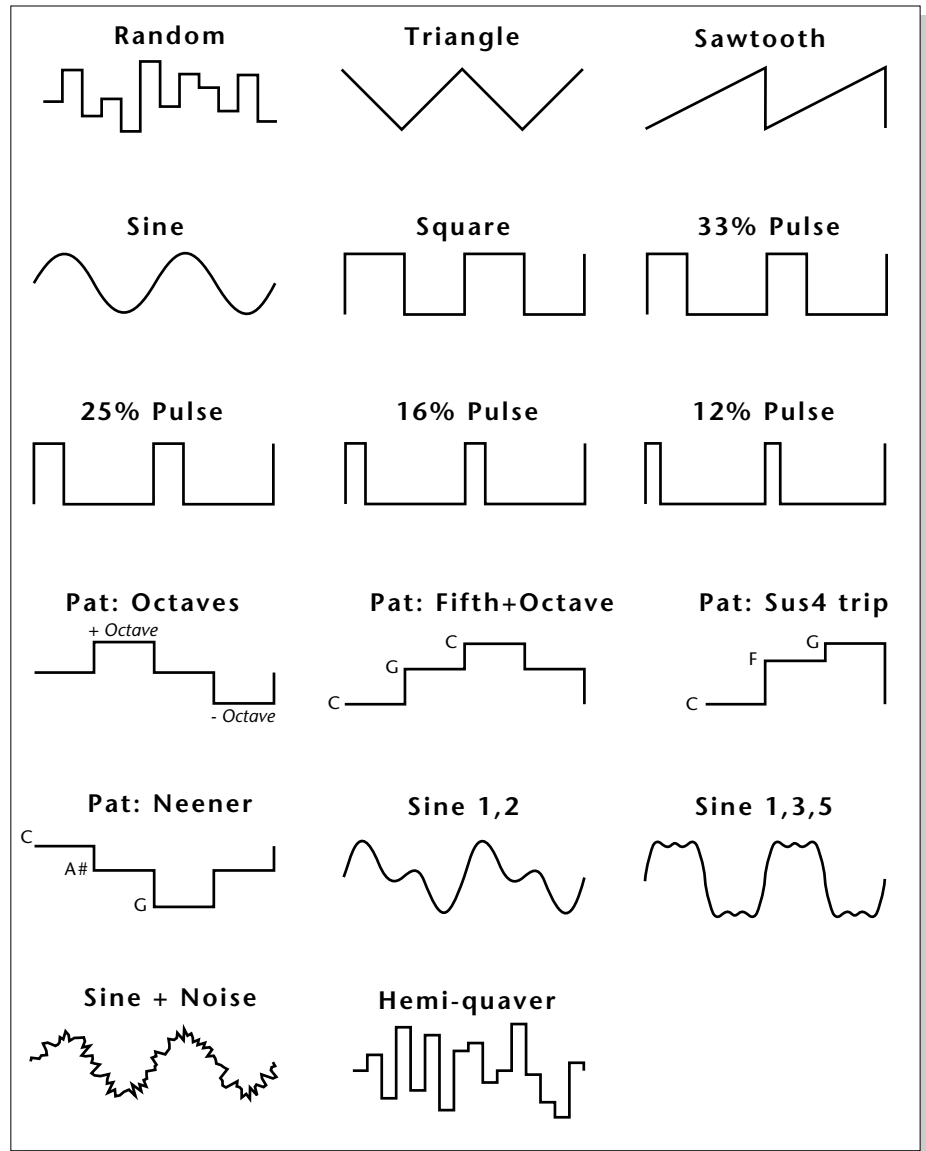

Lag Processors

The LFO 2 screen contains controls for the two lag processors used in the modulation Cords screens. Lag processors can be inserted in a modulation patch to inhibit rapid changes in the modulation source or cause it to lag behind the input. The amount (rate) of lag is adjustable from 0 to 10. A setting of 0 will cause the least amount of lag. 10 is the slowest lag. The diagram on the following page shows one way that a lag processor might be used.

To Program the Lag Processors:

1. From the Dynamic Processing level of the Preset Editor, **select the voice(s)** you wish to modify using the voice selection screen, then press the LFO/Aux function key (F4).
2. Use the **Previous** and **Next Page** buttons to locate the **LFO 2** screen.
3. Use the cursor buttons to select the **Lag Processors**.
4. Adjust the **Lag Time** of processor 1 or 2.
5. **Insert the Lag Processor** between a modulation source and destination in the Cords screen.
6. Press the **Exit** button to return to the Preset Definition level of the Preset Editor or press any of the dynamic processing function keys to move to another module.

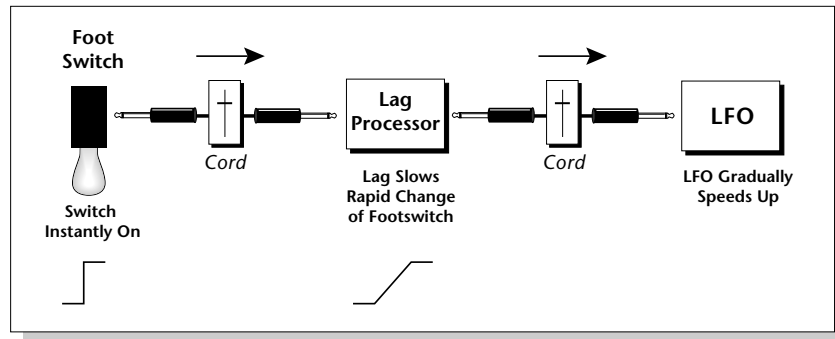

Auxiliary Envelope

The auxiliary envelope is a general purpose envelope generator that can be patched to any modulation destination.

To Set the Auxiliary Envelope:

1. From the Dynamic Processing level of the Preset Editor, **select the voice(s)** you wish to modify using the voice selection screen, then press the LFO/Aux function key (F4).
2. Use the **Previous** and **Next Page** buttons to locate the **Aux Envelope** screen.
3. Select and adjust the **Auxiliary Envelope** parameters. Use the cursor buttons to move the cursor around to the various parameters and the Data Entry Control or INC/DEC buttons to change the time and level of each stage.
4. Like the filter envelope generator, the auxiliary envelope allows you to set negative levels. This can be very useful to create attack “blips” when controlling the pitch of a voice.
5. Press the **Exit** button to return to the Preset Definition level of the Preset Editor or press any of the dynamic processing function keys to move to another module.

Cords

Modulation Sources

Off
 Crossfade Random
 Key (+, ~, <), Velocity (+, ~, <)
 Release Velocity, Gate
 Pitch Wheel, Mod Wheel
 Pressure, Pedal
 MIDI A-H, Foot Switch 1 & 2
 Flip-Flop Foot Switch 1 & 2
 MIDI Volume (Contr. 7)
 MIDI Pan (Contr. 10)
 Key Glide
 Volume Envelope (+, ~, <)
 Filter Envelope (+, ~, <)
 Aux. Envelope (+, ~, <)
 LFO 1 & 2 (+, ~)
 White Noise, Pink Noise
 kRandom 1 & 2,
 Lag 0 in (summing amp out)
 Lag 1 in (summing amp out)
 Lag Processor 0 & 1
 Clock Divisors
 DC Offset, Summing Amp
 Switch, Absolute Value
 Diode, Flip-Flop, Quantizer
 Gain 4x

Modulation Destinations

Off
 Key Sustain, Fine Pitch, Pitch
 Glide, Chorus Amt
 `Chorus Position ITD
 `Sample Start, Sample Loop
 Sample Retrigger
 Filter Freq., `Filter Resonance
 Amplifier Volume, Amp Pan
 Amplifier Crossfade
 Volume Envelope Rates (all)
 Vol. Env. Atk, Dcy, Release
 Filter Envelope Rates (all)
 Filt. Env. Atk, Dcy, Release
 Filter Envelope Trigger
 Aux. Envelope Rates (all)
 Aux. Env. Atk, Dcy, Release
 Aux. Envelope Trigger
 LFO 1 & 2 Rates
 LFO 1 & 2 Trigger
 Lag Processor In 0 & 1
 Summing Amp, Switch
 Absolute Value
 Diode, Flip-Flop, Quantizer
 Gain 4x, Cord 0-23 Amount

The 24 “patchcords” allow you to route modulation sources to destinations and control the amount of modulation. The cords connect everything together in the voice. There are only two permanently connected cords: amp envelope to amplifier, and key to pitch. Any other connections must be connected with a cord.

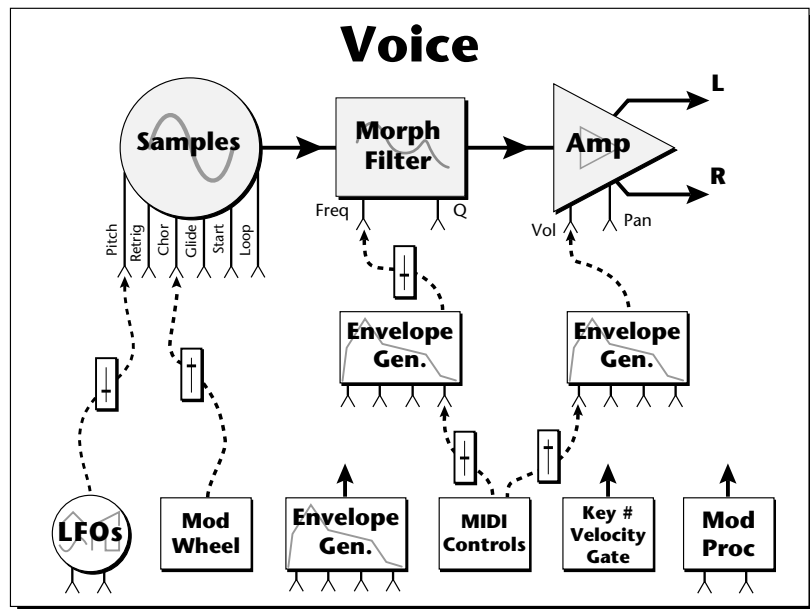

There are currently 64 modulation sources and 60 destinations for the patchcords. Some of the modulation sources, such as the lag processors and the diode, are control processors. They modify control signals. All these devices can be combined to create almost infinite patching possibilities.

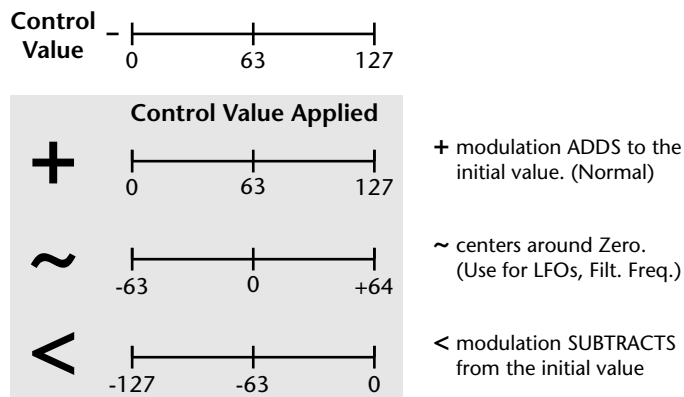

8 - Preset Edit Cords



Real-time events happen first on lower numbered cords, so it is usually a good idea to put important functions on lower numbered cords and to place components of complex modulations patches in the proper order in the Cords screens. This also makes it easier to visualize your patch.



Use negative cord amounts with an LFO to create a more realistic echo effect.



The Flip-Flop Footswitch will stay On until it is pressed again. Then it will toggle Off.

To Connect a Patch Cord:

1. From the Dynamic Processing level of the Preset Editor, **select the voice(s)** you wish to process using the voice selection screen
2. Press the **LFO/Aux** function key (F4).

Cords 00 to 05			IM1	V1: C-2:C7		
source	dest	amount	source	dest	amount	
00 :Yel<	AmpVol	+14%	03 :ModWl	C02Amt	+6%	
01 :PitWl	Pitch	+6%	04 :Yel<	FilFreq	+9%	
02 :Lfo1~	Pitch	+0%	05 :FEnv+	FilFreq	+14%	

Utils [Tuning Amp/Filt Lfo/Aux **Cords**] Zoom

3. Use the **Previous** and **Next Page** buttons to locate one of the four **Cords** screens.
4. **Connect the Modulation Sources to Destinations.** The list of all modulation sources and destinations is shown on the previous page.
5. Set the **Modulation Amount** for the Cord. Modulation amounts can be positive or negative. Keep in mind that modulation amounts interact with the initial settings.
6. Press the **Next** page button to move on to the second page and third pages of modulation cords. There are a total of 18 cords.
 - The **Zoom** key immediately jumps you to the screen related to the currently selected patchcord destination.
7. Press the **Exit** button to return to the Preset Definition level of the Preset Editor or press any of the dynamic processing function keys to move to another module.

Sample Retrigger

This modulation destination allows you to retrigger a sample using a modulation source. A **negative going, zero-crossing** triggers the sample from the sample start.

LFOs (~) and envelopes are obvious choices for trigger sources. By adjusting the envelope rates, you can time the onset of each sample retrigger. A continuous controller such as a mod wheel will retrigger the sample when it's turned all the way down. White and pink noise can be used for random retriggering. By adjusting the Amp Envelope to create an artificial decay, Sample Retrigger can be used to create echo effects.

To Retrigger the Sample:

1. From the Dynamic Processing level of the Preset Editor, **select the voice(s)** you wish to process using the voice selection screen, then press the Cords function key (F5).
2. Select a free **PatchCord** and connect any **negative going** modulation source (such as an LFO ~) to **SRetrig**.

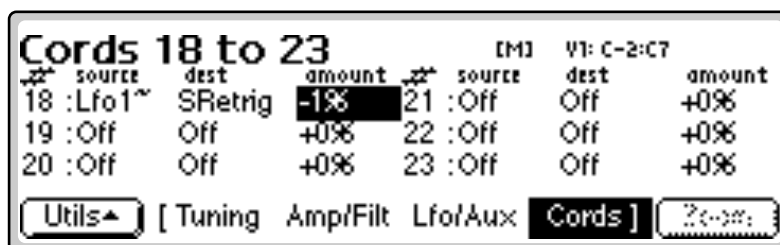

Cords 18 to 23			[M] V1: C-2:C7		
source	dest	amount	source	dest	amount
18 :Lfo1~	SRetrig	-1%	21 :Off	Off	+0%
19 :Off	Off	+0%	22 :Off	Off	+0%
20 :Off	Off	+0%	23 :Off	Off	+0%

Utils [Tuning Amp/Filt Lfo/Aux **Cords**] Exit

3. Set the **Cord Amount** to any value other than 0.
4. Press the **LFO/Aux** function key and use the page buttons to locate the LFO 1 screen.
5. Adjust the **LFO Rate** to the desired frequency. When a key is pressed, you should hear the sample retriggering.
6. Press the **Exit** button to return to the Preset Definition level of the Preset Editor or press any of the dynamic processing function keys to move to another module.

8 - Preset Edit

Disk Menu

9

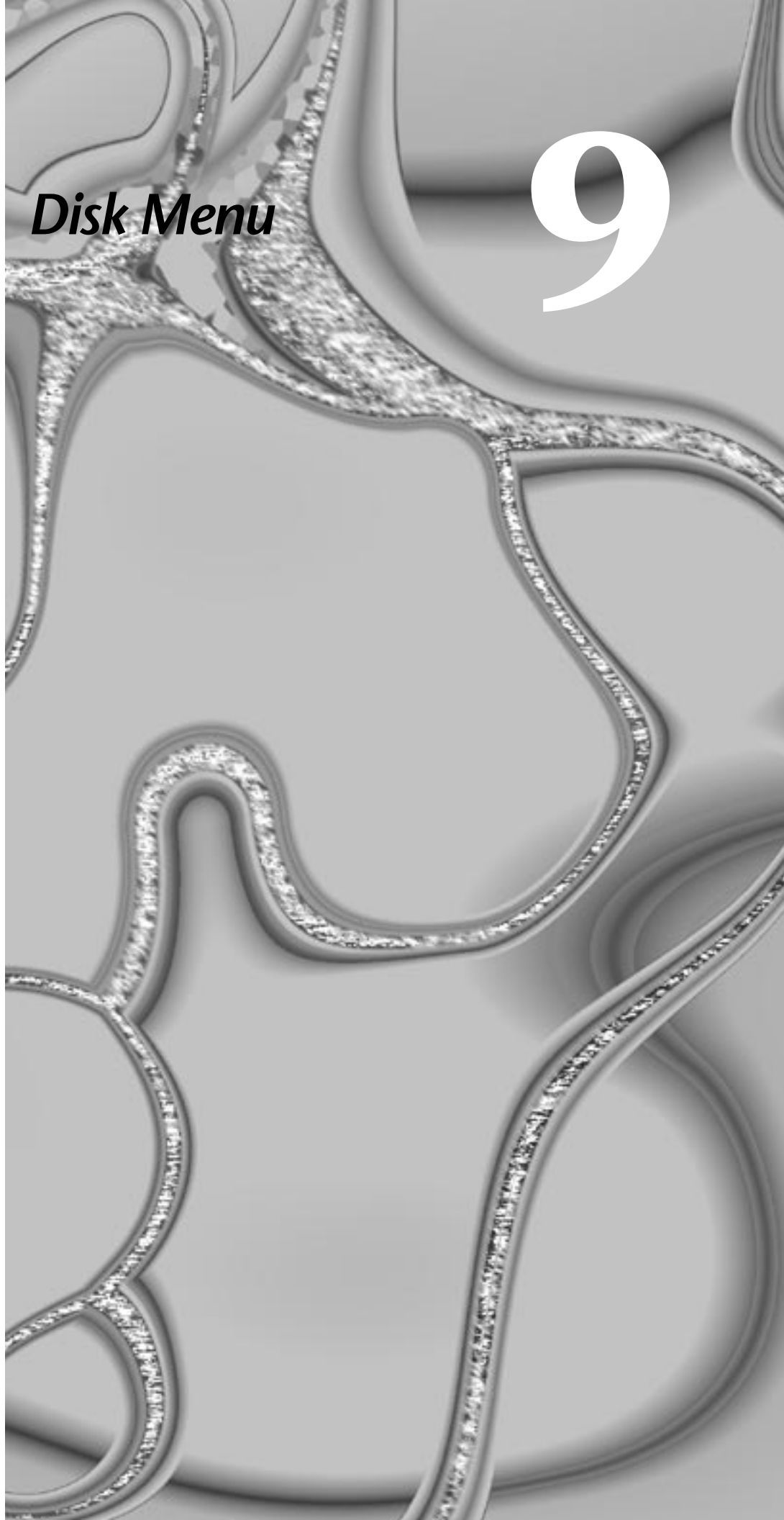

9 - Disk Menu

Disk Menu

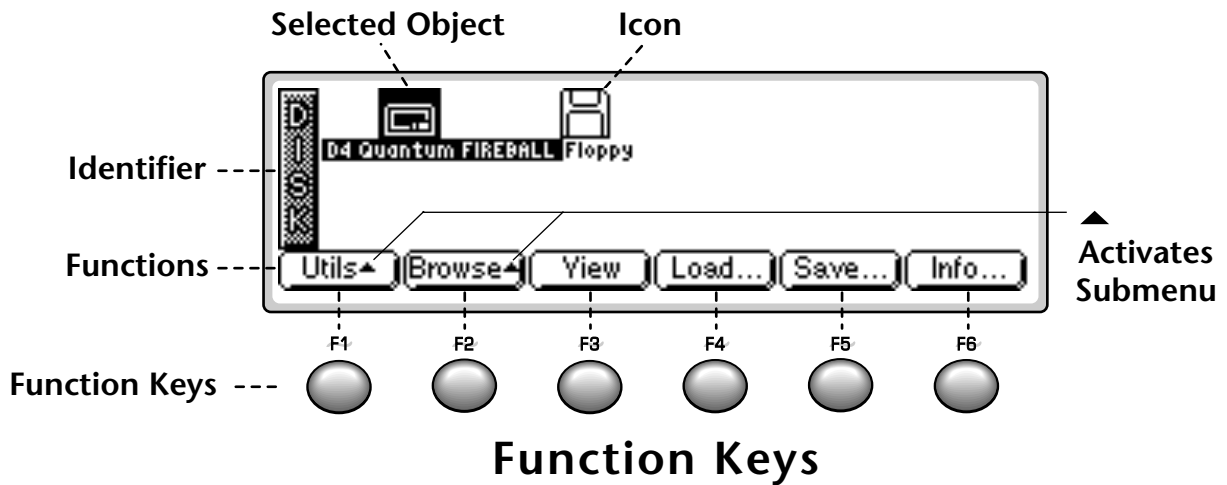

Disk Browser

The Disk Browser makes it easy to navigate through the different levels of the disk drives. Take the time to familiarize yourself with this section because the Browser is such an integral part of the system. A brief recap of the disk hierarchy is as follows:

Disk Drive . Floppy disk, hard disks, CD-ROM drives, optical drives, etc.

Folder . Used to group and organize collections of banks.

Bank . A group of presets which can be loaded into memory.

Preset . A complete keyboard layout containing: samples, voices and all programmable options.

Sample . An individual digital recording with looping information.

Sequence . A recording of keyboard key depressions (with velocity and pressure) and any other performance controllers (pitch and mod wheels, real time control sliders, Thumbby button, footpedal, foot switch and program changes). Sequences can be stored along with the Bank, copied to Preset Flash, or can be exported as separate MIDI files which appear as icons in the bank browser. See Chapter 5, Sequencer for details.

 The **Info...** key gives information about the selected object.

9 - Disk Menu

Disk Browser

 To turn *Sprint mode* On from the preset menu, press *Sprint* (F5).

 The *Disk Key* can be set to call up either *SoundSprint* mode or the Last screen you used in the *Disk Browser*. This preference is located under *Master, Setup, SCSI*.

To Browse the Disk:

1. Press the **Disk/Browse** key. The LED illuminates and the screen shown below appears.

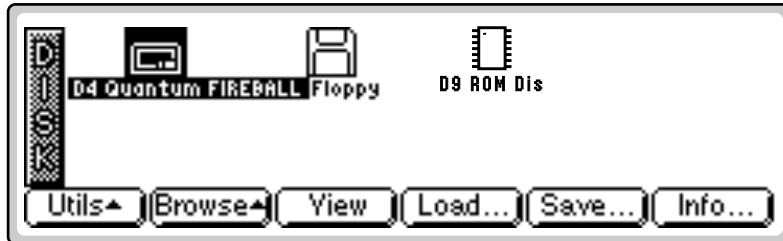

2. Press the **View** function key (F3). The display now changes to a list format. Press the View key again to return to the icon display.
3. Press the **Info...** function key (F6). A pop-up window appears with information about the hard disk drive. Press **OK** to return.



4. Press the **Browse** function key (F2). A second row of function keys appears.

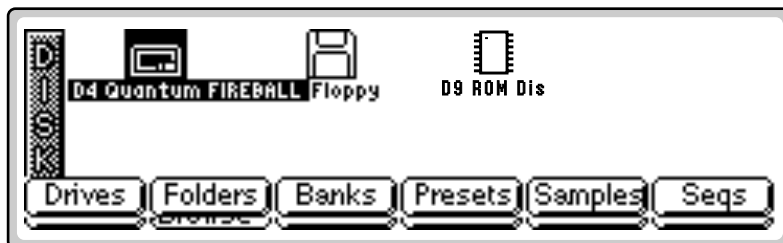

5. Press the **Folders** function key. The folders on the hard disk will be shown.

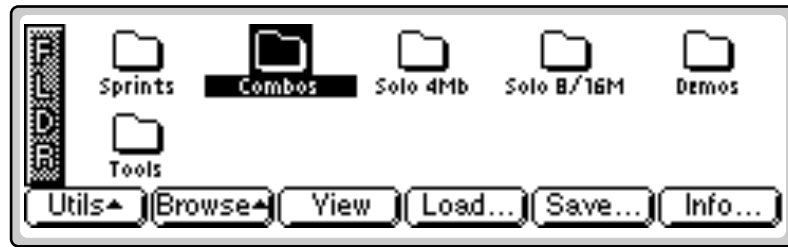

6. The display now shows the various folders of banks resident on the hard disk. Use the cursor keys, INC/DEC keys or the Data Entry Control to select the active object.
 - If another page of choices exists, the Right Page arrow LED will be illuminated.
7. Choose a **Folder**, then press the function key under **Browse** again. Press the function key under **Banks** to examine the banks in the selected folder.

 The Enter key can be used to step forward through the Folder, Bank, Preset and Sample browsers.

Use the Exit key to back out of the pages.

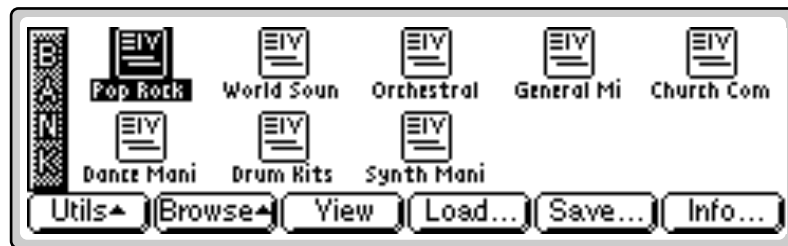

8. Choose a **Bank**, then press the function key under **Browse** again. Press the function key under **Presets** and the Preset screen shown below appears.

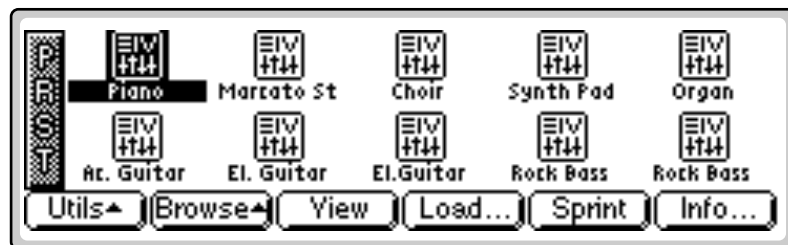

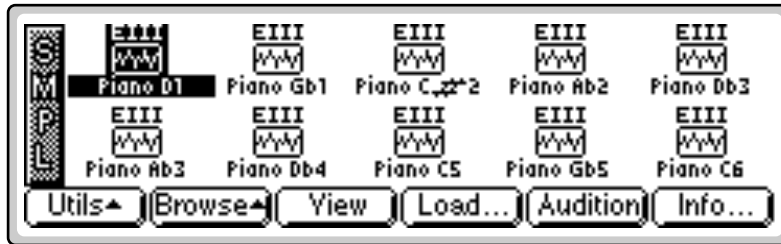

9. Choose a **Preset**, then press the function key under **Browse** yet again. Press the function key under **Samples** to examine the samples used in the selected bank.

9 - Disk Menu
Disk Browser

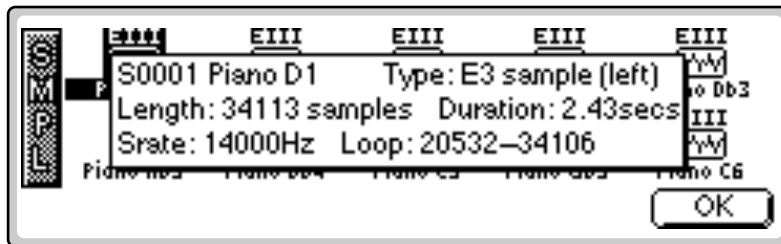

10. Press the **Info...** function key (F6). a pop-up window appears with information about the sample. Press **OK** to return.



 The **Enter** key can be used to step forward through the Folder, Bank, Preset and Sample browsers.

Use the **Exit** key to back out of the pages.

11. Pressing the **Exit** key “backs you out” of the pages. Press the **Exit** key once from the sample browser to return to the preset browser. Pressing **Exit** again puts you in the folder browser. Press it once more and you're in the disk browser. Press **Exit** one more time and you're out of the disk module altogether and back in the preset selection screen.
12. Press **Browse**. Press **Seqs** to examine or load the sequences resident in the selected bank. If no sequences exist, a pop-up window will inform you of this fact.



Disk

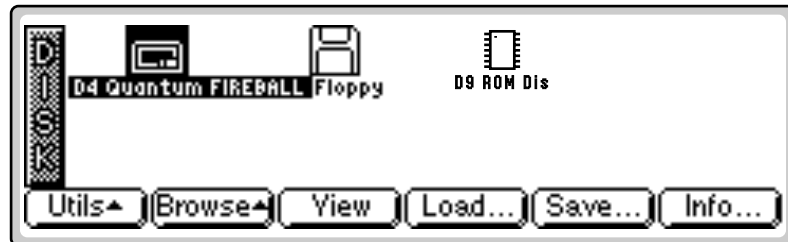

The Disk page of the Browser contains functions and operations related to storage media such as floppy disks, hard disks, CD-ROM drives, magneto-optical drives or whatever. When in the Disk page, all drives which are connected to the SCSI port appears as icons in the display.

Disk Utilities

The Disk Utilities menu contains several additional functions. Pressing the **Utils** function key (F1) from the disk browser enables a second row of function keys.

Mount Drives: Instructs the Emulator to check the SCSI bus for the presence of SCSI devices.

Copy System: Allows you to copies of the EOS operating system supplied on floppy disk by E-mu Systems or your authorized dealer.

Format Disk: Allows you to format floppy disks or install the EOS file system on pre-formatted hard disks. This method is much faster than LL Formatting.

LL Format: This option takes longer but formats the hard disk at the lowest level and maps out bad sectors.

Backup: Hard disk drives can and do fail from time to time. This function allows you to backup and restore your valuable data to another hard disk or SCSI media.

Find: Helps you find specific Sequences, Samples, Presets, Folders and Banks anywhere in your library.



ALWAYS re-mount a removable media drive after swapping disks.

Mount Drives

This utility checks the SCSI bus for the presence of SCSI devices. Use this function whenever a connected SCSI device does not appear in the Disk Browser or whenever you swap cartridges from a removable media disk drive.

To Mount Drives:

1. From the Disk Browser, press the **Utilities** function key (F1).
2. Press the **Mount** function key (F1). The Emulator will mount all SCSI devices.

Copy System

From time to time the EOS operating system will be updated with new features and functions. This software is usually distributed on floppy disk and can be permanently copied into the Emulator's Flash RAM so that it will automatically load whenever you turn on the Emulator. Software can also be saved to a floppy disk in order to back it up.

Each version of software is numbered and is indicated when you select "About" under the "Utilities" menu in the Master module. Copying software will not affect any other data such as samples or presets.

To Update the EOS Software:

1. **Turn off power** to the Emulator.
2. **Insert the software floppy disk** with the label side left (label side up on the E4K or E-Synth Keyboard).
3. **Turn on power** to the Emulator. The display will show the software version on the floppy and ask if you wish to update Flash RAM from the floppy software.
4. Press **Enter** to update, or **Exit** to cancel the operation.
5. Re-initialize EEPROM. (This should be done after a software update to "clean the slate". It resets the Master menu preferences and other bits.)
 - a. Press **Master, Utils, Tests**
 - b. Enter the Secret Password: **1-3-5-8**, then press **OK**.
 - c. Press **More**, then **InitEE** The display reads, "Initialize EE?"
 - d. Press **OK**. The display reads, "Saving System". Press **Master** to exit.
6. Recalibrate the Emulator controls. See "Recalibration" on page 68.



Caution: Re-initializing EEPROM resets the "Avoid Host on SCSI ID" parameter to "None". If you have a computer on the SCSI bus, be sure to set this parameter to the correct ID.

To Backup the EOS Software to Floppy Disk:

1. From the Drives Browser, press the **Utilities** function key (F1).
2. Press the **CopySys** function key (F2). The display will ask you to insert a floppy disk. Insert a formatted floppy disk label side left (label side up on the E4K or E-Synth Keyboard). If the floppy disk is unformatted, you will be asked if you want to format it.)
3. Press **Yes** to copy the system to the floppy disk. Press **Cancel** or **Exit** to cancel the operation and return to the disk browser.

Format Disk

Before a new floppy disk or hard disk can record or store any data, it must be told how to record this data. This is called formatting. The floppy disk formatting procedure should be run on any new disk, or on recycled disks previously used with other systems (such as personal computers) since these will not be formatted correctly. If the hard disk drive is not shown in the disk browser, use the Mount Drive function.

Many new hard disk and optical drives as well as removable hard disk cartridges now come pre-formatted. This function allows you to install the EOS file system on pre-formatted hard disks without having to reformat the disk. This can save quite some time, especially with large capacity disks. To find out if a disk is pre-formatted, try the Format Disk procedure first. If this doesn't work, use the Low Level Format procedure.

To Format a Floppy Disk:

1. From the Disk Browser, **select the floppy drive** using the Data Entry Control, cursor keys or INC/DEC keys.
2. Press the **Utilities** function key (F1).
3. Press the **Format** function key (F3). The display will ask you to insert a floppy disk. Insert a floppy disk with the label side toward the center of the Emulator (label side up on the E4K or E-Synth Keyboard).
4. Consider the implications of your action. Formatting a floppy disk erases all information on that disk, completely. Press **OK** to format the disk or **Cancel** to cancel the operation. Formatting takes about two minutes.
5. After formatting the floppy disk, format another if desired. The display will ask you if you want to format another floppy. To do this, press **Yes**, remove the current disk, insert a new disk and press **OK**. Otherwise, press **Cancel** or **Exit** to cancel the operation and return to the disk browser.

To Format a Hard Disk or Optical Disk:

1. From the Disk Browser, **select the desired SCSI drive** using the Data Entry Control, cursor keys or INC/DEC keys.
2. Press the **Utilities** function key (F1).
3. Press the **Format** function key (F3). The display will warn you if you are about to destroy data.
4. Press **OK** to Install the file system on the disk or **Cancel** to cancel the operation. Installing the file system time takes a minute or more, depending on the size of the disk.

 EOS can read both EOS and DOS formatted floppies. DOS floppies can be formatted on PCs or Mac computers

EOS floppies can hold only one bank per disk, but can use multiple disks to hold large banks.



EOS floppy icon

DOS floppies can hold up to 50 small files and so are a good choice for storing small banks and MIDI sequences. However, you cannot save a large file onto multiple DOS floppies.



DOS floppy icon

Low Level Format

Low Level Formatting formats the disk at the lowest level and attempts to map out any bad sectors. When connecting a new disk, always try the regular format procedure first as this saves considerable time.

To Low Level Format a Hard Disk or Optical Disk:

1. From the Disk Browser, **select the desired SCSI drive** using the Data Entry Control, cursor keys or INC/DEC keys.
2. Press the **Utilities** function key (F1).
3. Press the **LLFormat** function key (F4). The display will warn you if you are about to destroy data.
4. Press **OK** to format the disk or **Cancel** to cancel the operation. Formatting time varies depending on the size of the disk.

Backup

This function allows you to backup and restore a portion or the entire contents of the hard disk. You should develop the habit of backing up any and all important data or risk catastrophe at some future date. If you'd hate to lose it, BACK IT UP!

To Backup your Hard Disk Data:

1. From the Disk Browser, **select the SCSI drive** you want to back up using the cursor keys, INC/DEC keys or the Data Entry Control.
2. Press the **Utils** function key (F1).
3. Press the **Backup** function key (F5). The display will warn you if you are about to overwrite the current bank in RAM.
4. Press **OK** to continue or **Cancel** to cancel the operation. The following screen appears.

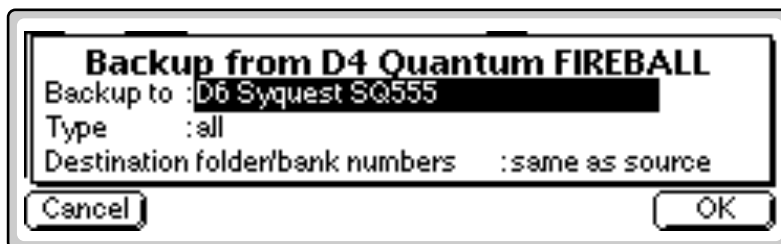

5. **Select the destination drive** using the INC/DEC keys, or Data Entry Control.
6. Move the cursor down to "Backup Type" and select the type of **Backup Type** with the INC/DEC keys or Data Entry Control.

 Use "Same as Source" when backing up to an ESI-32 or EIIIX drive if you want these machines to see your EOS files. They will overwrite any files stored in those locations. The ESI-32 and EIIIX cannot load EOS files, but the drive can be used for both machines. Use "Use Empty" if backing up to an ESI-32 or EIIIX drive and you want the EOS files to be invisible to those machines. In this case, ESI or EIIIX files will not be overwritten.

Your choices are:

- **All:** Transfers all banks from the source disk to the destination disk.
- **Range:** Transfers a selected range of banks from the source disk to the destination disk.
- **Incremental:** Transfers only those banks which have been modified since the last backup.

Incremental Backup works by turning on a "bit" (stored with the bank) whenever a bank is created or modified. Whenever you backup the bank, the bit is turned off. Because the bit is turned off on the first backup, do not use incremental backup if you want to make multiple backup disks.

7. Move the cursor down to "Destination folder/bank numbers" to select where the banks will be placed on the destination disk.

Your choices are:

- **Same as Source:** Copies the banks into the same numbered bank locations on the destination disk.
 - **Use Empty:** Copies the banks into a new folder on the destination disk.
8. When you have made your choices, press **OK** to continue or **Cancel** to cancel the operation. Choosing All or Incremental causes the backup to begin immediately. Choosing "Range", causes the following screen to appear.



9. Select the **Folder** to be copied.
10. Select the **Starting** and **Ending** banks of the range to be copied, then press **Backup**.

To Restore your Hard Disk Data:

- **Select your Backup Disk** in the disk browser and simply backup to your regular work disk.

Load Bank

A bank can be loaded directly from the disk browser.

☞ To Load a Bank:

1. From the Disk Browser, press the **Load** function key (F4). The following screen appears:



If the bank to be merged is not a native EOS bank, it's impossible for EOS to know the exact size in advance and the merge may not be completed.

2. **Choose a bank to load** using the Data Entry Control, INC/DEC keys or the numeric keypad. You may also change the current drive or folder by using the up/down cursor keys to select the drive or folder. Press **OK** to load the bank or **Cancel** to cancel the operation. If you pressed "OK" the bank will be loaded and the main preset selection screen appears.
3. If there is a bank already loaded, the following warning screen appears. press **OK** to overwrite the previously loaded bank or **Cancel** to cancel the operation.

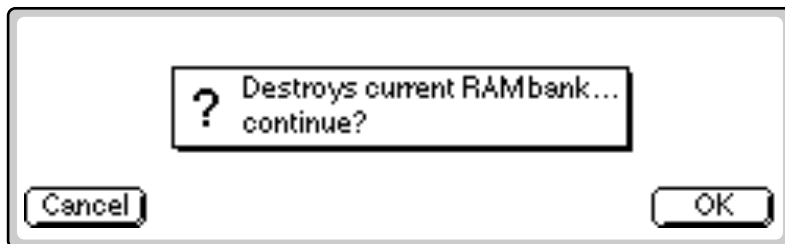

A "Memory Full" error will occur if you try to merge two banks which together contain more than 50 sequences.

4. Press **Load** again. The *Merge* button (shown above) allows you to combine the new bank with the bank that was previously loaded.
5. Press **Merge** to combine the two banks of presets or **OK** to continue. The display will warn you if there isn't enough memory to hold both banks.

Note:

EIII presets are translated into EOS presets as they are loaded. EOS voices are much bigger than EIII voices. By contrast, EOS sample zones within voices are tiny. At import/load time, EOS tries to collapse adjacent EIII voices into EOS voice+sample zones if it can (Envs, LFOs, etc. must be the same), otherwise, it creates voices. Therefore, EIII presets that use lots of differing voices really balloon in EIV. Simpler presets (Proteus-type presets which have the same settings for all samples) may collapse into a single voice.

Save Bank

A bank can be saved to disk from the disk browser.

To Save a Bank:

1. From the Disk Browser, press the **Save** function key (F5). The following screen appears:

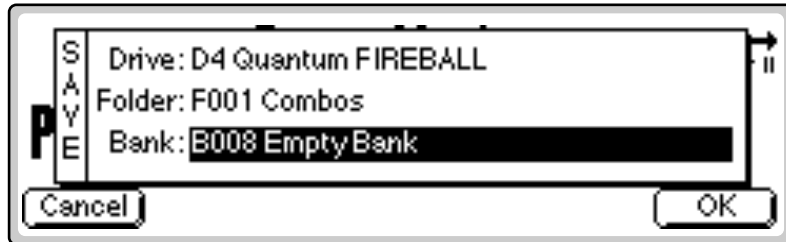

2. **Choose a location for the bank** using the Data Entry Control, the INC/DEC keys or the numeric keypad. You may change the current drive or folder by using the up/down cursor keys to select the drive or folder. Press **OK** to load the bank or **Cancel** to cancel the operation. If you pressed "OK" the bank will be saved and the main preset selection screen appears. If you are about to overwrite an existing bank, the display will warn you.

View...

The display can be changed to a list format instead of the normal icon-based format.



To Change the Display View:

- From the Disk Browser, press the **View** function key (F3). The screen will change to a list format. The List view is shown below. Pressing the **View** function key again toggles the view back to icon view.

Info, Lock Drive, & Sleep

This function displays information on the selected disk drive and also allows you to Lock the drive to prevent inadvertent erasure or tampering.

To Get Disk Info:

- From the Disk Browser, press the **Info...** function key (F6). A pop-up window appears with the vital statistics of the selected disk.

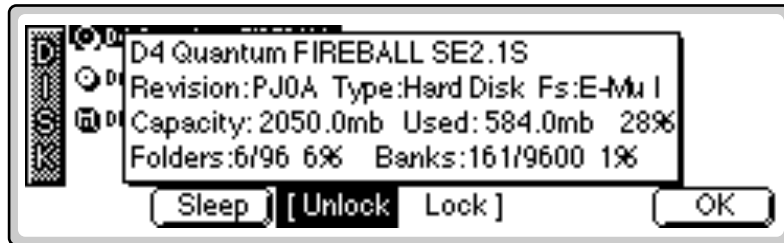

 The lock function actually locks the SCSI ID and not the drive. If you move a locked drive to another Emulator, it will be erasable.

Lock

A disk drive can be locked and unlocked to protect it from inadvertent erasure or tampering.

To Lock or Unlock a Drive:

1. To lock the selected disk, press the **Lock function** key (F4).
2. Press **OK** (F6). The drive will be write protected until you unlock it.
3. To unlock the disk, press the **Unlock** function key (F3), then press **OK** (F6).

Sleep

A disk drive can be put to "Sleep" in order to cut down on noise in the quiet studio environment.

To Put a Drive to Sleep:

1. To put a drive to sleep, press the **Sleep** function key (F2).
2. The drive will be put to sleep.
3. To wake the Drive, **select the Drive**, then press **Enter**.

 **Warning:** When chaining multiple Emulators via SCSI, all must be running EOS 4.0 for Drive Sleep to work properly. If you use "Drive Sleep" under these conditions units may freeze, causing data loss.

Folder

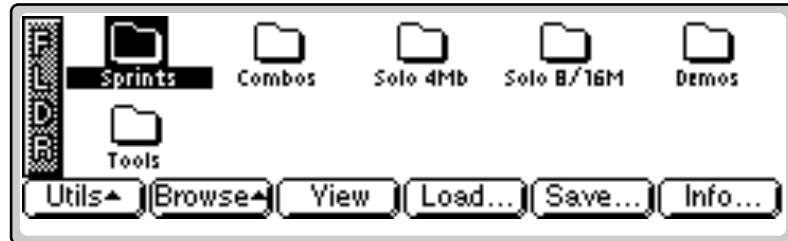

Folders help you organize your banks of sounds by providing another level between the bank and disk level. You may want to organize your banks by a particular project or by the type of sounds contained within, such as: Sound Effects, Pianos, Strings, etc. If you do not wish to use folders, simply place everything on the disk into one folder. You can skip over the folder level in the browser and forget that folders even exist.

Folder Utilities

The Folder Utilities menu contains several additional functions. Pressing the Utils function key (F1) from the folder browser enables a second row of function keys.

New: Allows you to create a new folder.

Delete: Allows you to delete an unwanted folder

Rename: Allows you to rename the selected folder

Find: Allows you to search your disk(s) for a particular folder.

New

This utility allows you to create a new folder.

To Create a New Folder:

1. From the **Folder Browser**, press the **Utilities** function key (F1).
2. Press the **New** function key (F2). A pop-up window appears prompting you to name your new folder.
3. Press **OK** after naming the new folder and it appears on the screen.

Delete

This utility lets you to delete a folder and all of its contents.

To Delete a Folder:

1. From the Folder Browser, **select the folder** you wish to delete using the cursor keys, INC/DEC keys or the Data Entry Control.
2. Press the **Utilities** function key (F1).
3. Press the **Delete** function key (F3). A pop-up window appears asking you if you want to delete the folder.
4. Press **OK**(F6) to delete the folder and its contents or **Cancel** (F1) to cancel the operation.

Rename

Use this utility to rename a folder.

To Rename a Folder:

1. From the Folder Browser, **select the folder** you wish to rename using the cursor keys, INC/DEC keys or the Data Entry Control.
2. Press the **Utilities** function key (F1).
3. Press the **Rename** function key (F4). A pop-up window appears prompting you to rename the folder.
4. **Change the name of the folder.** Select letters using the numeric pad, Data Entry Control, INC/DEC and cursor keys, or an ASCII keyboard.
5. Press **OK** (F6) to confirm the new name or **Cancel** (F1) to cancel the operation.

 The up/down cursor keys add and delete spaces when renaming. The tab key on an ASCII keyboard clears the entire name.

Find...

This utility searches your hard disks for folders, banks, presets, samples or sequences using a search string (a pattern of letters and numbers). If it finds the selected string anywhere in the name, the item will be selected.

To Find:

1. From the Folder Browser, press the **Utils** function key (F1).
2. Press the **Find** function key (F6). The screen shown below appears.

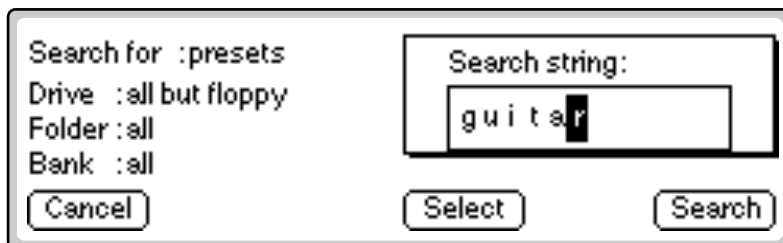

The screenshot shows a window titled "Find...". On the left side, there are four labels with corresponding values: "Search for : presets", "Drive : all but floppy", "Folder : all", and "Bank : all". At the bottom left is a "Cancel" button. On the right side, there is a "Search string:" label above a text input field containing the text "guitar". Below the input field are two buttons: "Select" and "Search".

3. **Select the type of item** (folder, bank, preset, sample or sequence) you wish to search for. If you have an idea of where the item is located, you can narrow the search by inputting additional data on the drive, folder or bank. Selecting "All" tells EOS to search everything.
4. Press the **String** function key (F4), and enter the search string. Letters can be selected using the numeric pad, Data Entry Control, INC/DEC keys and cursor keys, or using an ASCII keyboard.
5. Press the **Search** function key (F6) to search for the item or **Cancel** (F1) to cancel the operation.

View

The display can be changed to a list format instead of the normal icon-based format.

To Change the Display View:

- From the Folder Browser, **press the View function key (F3)**. The screen will change to a list format. Pressing the View function key again toggles the view back to icon view.

Info...

Info displays information on the selected folder.

To Get Folder Info:

- From the Folder Browser, press the **Info...** function key (F6). A pop up window appears with the vital statistics of the selected disk.

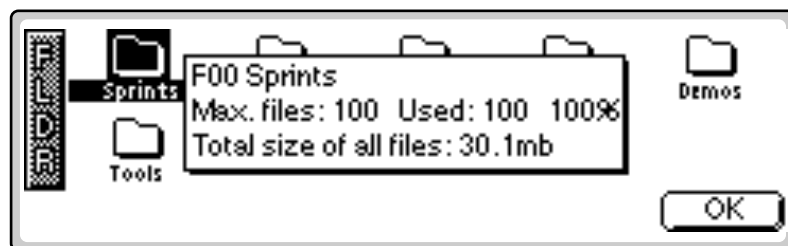

Bank

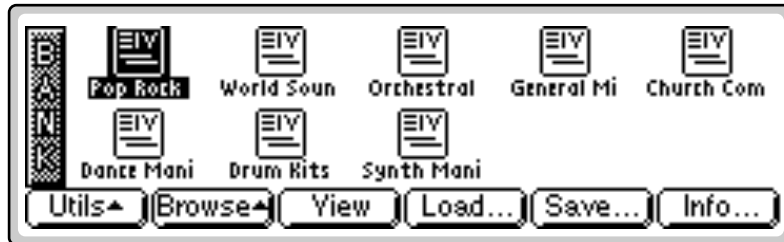

The Bank is a set of up to 1000 presets which can be loaded into and saved to disk from internal memory (RAM). When you save to disk, that collection of presets, samples and sequences is a bank. Banks can be constructed as large as the memory in your Emulator will allow (64 MB or 128 MB).

Bank Utilities

The Bank Utilities menu contains several additional functions. Pressing the Utils function key (F1) from the bank browser enables a second row of function keys.

Delete: Allows you to delete an unwanted bank.

Name: Allows you to name or rename the selected bank.

Find: Allows you to search the disk for a particular bank.

Delete

This utility allows you to delete an entire bank.

To Delete a Bank:

1. From the Bank Browser, **select the bank** you wish to delete using the cursor keys, INC/DEC keys or the Data Entry Control.
2. Press the **Utilities** function key (F1).
3. Press the **Delete** function key (F3). A pop-up window appears asking you if you want to delete the bank.
4. Press **OK** (F6) to delete the bank or **Cancel** (F1) to cancel the operation.

Name

This utility allows you to rename a bank.

To Name a Bank:

1. From the Bank Browser, **select the bank** you wish to rename using the cursor keys, INC/DEC keys or the Data Entry Control.
2. Press the **Utilities** function key (F1).
3. Press the **Name** function key (F4). A pop-up window appears prompting you to name the bank.
4. **Change the name of the bank.** Letters can be selected using the numeric pad Data Entry Control, INC/DEC keys and cursor keys, or using an ASCII keyboard.
5. Press **OK** (F6) to confirm the new name or **Cancel** (F1) to cancel the operation.

Find...

This utility searches your disk library for a particular pattern of letters and numbers (a search string). If it finds the string anywhere in the name, the bank will be selected. Use the Find utility again to find additional matching items.

To Find:

1. From the Bank Browser, press the **Utilities** function key (F1).
2. Press the **Find** function key (F6). The screen shown below appears.



Search for : presets
 Drive : all but floppy
 Folder : all
 Bank : all

Search string:
 guit

Cancel String Search

3. **Select the type of item** (folder, bank, preset, sample or sequence) you wish to search for. If you have an idea of where the item is located, you can narrow the search by inputting additional data on the drive, folder or bank. Selecting "All" tells EOS to search everything.
4. Press the **String** function key (F4), and enter the search string. Letters can be selected using the numeric pad, Data Entry Control, INC/DEC keys and cursor keys, or using an ASCII keyboard.
5. Press the **Search** function key (F6) to search for the item or **Cancel** (F1) to cancel the operation.



A "Memory Full" error will occur if you try to merge two banks which together contain more than 50 sequences.



Hot Tip! To save all the samples in a bank in **EIIIx**, **WAVE** or **AIFF** format, press and hold the decimal point key while you press the Save function key. The display will offer you the option to save in these alternate formats. Press the function key under your choice of formats, then press OK.

Note that the preset information is **NOT** transferred, only the samples.

Load Bank

A bank can be loaded from the bank browser.

To Load a Bank:

1. From the Bank Browser, **select the bank you wish to load** using the cursor keys, INC/DEC keys or the Data Entry Control.
2. Press the **Load** function key (F4). Loading a bank overwrites the bank currently in memory unless you choose to Merge the banks.
3. Press **Yes** to overwrite the current bank or **Cancel** to cancel the operation.
4. Press **Merge** to add the new bank to the current bank in memory.
5. A pop-up dialog box appears, prompting you to select the starting destination preset. Use the Data Entry Control, INC/DEC keys or the numeric pad to select the starting destination preset. As the new bank is merged, its presets will "fill in" any empty presets after this preset.

Save Bank

A bank can be saved to disk from the bank browser.

To Save a Bank:

1. From the Bank Browser, press the **Save** function key (F5). The following screen appears:



2. **Choose a location for the bank** using the Data Entry Control, the INC/DEC keys or the numeric keypad. You may change the current drive or folder by using the up/down cursor keys to select the drive or folder. Press **OK** to load the bank or **Cancel** to cancel the operation. If you pressed "OK" the bank will be saved and the main preset selection screen appears. If you are about to overwrite an existing bank, the display will warn you.
- If the bank contains SoundSprinted presets (presets in locations 990-999), the display will ask you if you want to save the SoundSprint presets along with the bank.

View

The display can be changed to a list format instead of the normal icon-based format.

To Change the Display View:

1. From the Bank Browser, press the **View** function key (F3). The screen will change to a list format.
2. Pressing the **View** function key again toggles the view back to icon view.

Info...

Information on the selected bank can be displayed.

To Get Bank Info:

1. From the Bank Browser, press the **Info...** function key (F6). A pop up window appears with the vital statistics of the selected bank.
2. Press **OK** to return to the bank browser.

Preset

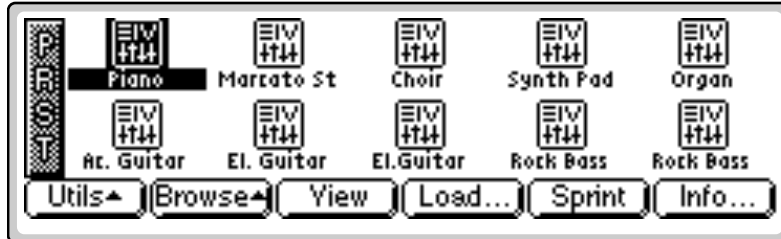

A preset is one complete keyboard setup containing voices and samples arranged on the keyboard together with all programmable synthesizer parameters.

Preset Utilities

The Utilities menu contains two functions. Pressing the Utils function key (F1) from the Preset Browser enables a second row of function keys.

Sprint: Toggles SoundSprint™ mode on and off.

Find: Allows you to search the disk for a particular bank.

SoundSprint™

SoundSprint is a browser mode which automatically loads a preset as it is selected in the preset browser. The currently loaded preset remains active until the new preset is loaded.

Presets loaded via SoundSprint are placed at the top of the bank memory and are assigned preset numbers 990-999.

Up to ten Sprint presets can reside in RAM and can be instantly selected. Loaded presets remain in RAM until the memory capacity is exceeded, at which time the oldest sprint preset is erased. (Sprint will not erase the current preset.)

A “Memory Full” message will be displayed if the new preset cannot load without overwriting the current preset. This message may also appear if you have a conventional bank loaded.

Linked presets are NOT loaded using SoundSprint. Only the selected preset will be loaded.

 Links can be subsumed into the parent preset using the Subsume function (Preset Edit, Link, Utils).

 The Disk Key can be set to call up either SoundSprint mode or the Last screen you used in the Disk Browser. This preference is located under Master, Setup, SCSI.

 SoundSprint can be also be accessed by holding the Set/Shift key (decimal point) and pressing Assignable Key 3.

 Browse>Presets bypasses the SoundSprint function and allows you to assemble presets to save as a bank.



 **To Turn SoundSprint Mode On:**

- From the main preset screen, press the Sprint function key (F3). The following screen appears and the selected preset will be automatically loaded. You can also press Sprint (F5) from the Preset Browser. The preset will be loaded from the last bank selected in the Disk Browser.

Other banks which are accessible by pressing the Bank function keys (F5 and F6).

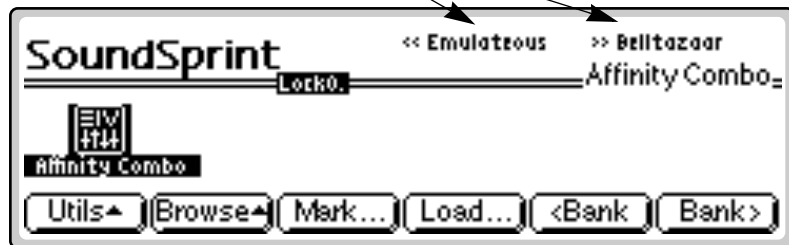

 **To Turn SoundSprint Mode Off:**

1. From the SoundSprint Browser, press the **Utilities** function key (F1).
2. Press the **SprntOff** function key (F5). The Preset Browser screen appears and SoundSprint mode will be turned off.

 **To Select Presets using SoundSprint:**

1. From the SoundSprint Browser, **select presets in the normal way** using the left/right cursor keys, page keys or data entry control. The selected preset will automatically begin loading as soon as it is selected.
2. Press the **Page** key to selected another page of presets. An illuminated red arrow beside the page key indicates if there is another page of presets in that direction.
3. At the top of the SoundSprint menu there may be other banks listed as in the SoundSprint screen on the previous page. These banks may be selected using the <Bank and Bank> function keys (F5 and F6).



FLASH RAM memory is retained even with the power turned off.



Press and hold the decimal point key, then press the +/- key to instantly save your bookmarks to Flash RAM



The alternate bookmark setting method can only set bookmarks 0-9 of the current rank.

Bookmarks

When in SoundSprint mode, you can attach Bookmarks to your favorite presets so that they can be instantly selected with a single or double key press. Up to 100 bookmarks can be stored and saved to nonvolatile FLASH RAM.

To Set a Bookmark:

1. From the SoundSprint Browser, **select the preset** you wish to bookmark using the left/right cursor keys.
2. Press the **Mark...** function key (F3). The following screen appears.

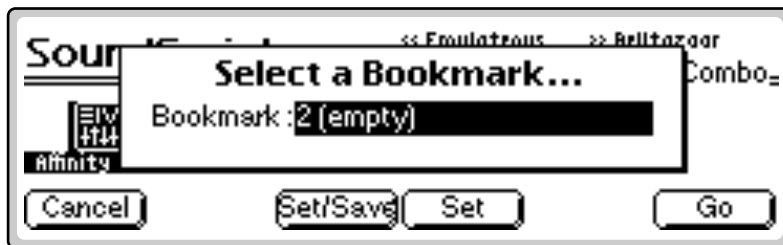

3. **Select a bookmark location** using the Data Entry Control or INC/DEC keys.
4. After selecting a location, press the **Set** function key (F4) to set the bookmark.
5. Press the **Set/Save** function key (F3) if you want to save the bookmarks to nonvolatile memory.
 - The numeric keypad selects a bookmark from the rank of 10 you last selected with the Lock engaged.
6. Press the **Go** function key (F6) to go to the currently selected preset.
7. Press **Cancel** (F1) to cancel the operation.

Alternate Method to Set a Bookmark:

1. From the SoundSprint Browser, **select the preset** you wish to bookmark using the left/right cursor keys.
2. **Press and hold the Set key** located to the right side of the numeric keys. While holding the Set key, press one of the numeric keys. A pop up dialog box will inform you that the bookmark is set.

To Select a Bookmark:

1. From the SoundSprint Browser, **simply press the numeric key(s) corresponding to the bookmark you wish to select.** For example, if you wanted to select the preset at bookmark number 9, **press 9** on the numeric keys. The preset will be selected.

- The Lock key locks the first digit of the two digit bookmark number. **Press and hold the Lock key** (located to the left of the numeric keys) while pressing one of the numeric keys to lock the most significant digit. Press the Lock key by itself to turn Lock mode On or Off. The lock indicator on the display is shown below.

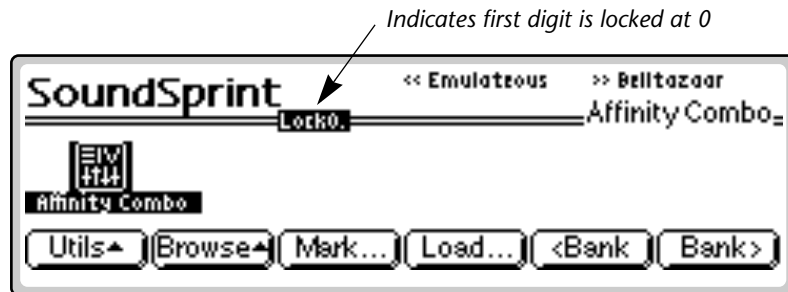

- With Lock Off, two digits must be entered to select a bookmark. For example, **to select bookmark 9**, you would press **0**, then **9**.
- With the most significant digit locked, only one key press is required to select a bookmark.
- To select another rank of 10 bookmarks, **press and hold the Lock key** and **press one of the numeric keys**. The display will inform you which rank of 10 bookmarks is now selected.

Find...

This utility searches your disk library for a particular pattern of letters and numbers (a search string). If it finds the selected string anywhere in the name, the bank will be selected. Use the Find utility again to find additional matching items.

To Find:

- From the Preset Browser, press the **Utilities** function key (F1).
- Press the **Find** function key (F6). The Find screen appears.
- Select the type of item** (folder, bank, preset, sample or sequence) you wish to search for. If you have an idea of where the item is located, you can narrow the search by inputting additional data on the drive, folder or bank. Selecting "All" tells EOS to search everything.
- Press the **String** function key (F4), and enter the search string. Letters can be selected using the numeric pad, Data Entry Control, INC/DEC keys and cursor keys, or using an ASCII keyboard.
- Press the **Search** function key (F6) to search for the item or **Cancel** (F1) to cancel the operation.

Load Preset

An individual preset can be loaded into the bank from the preset browser. This is a way you can create your own custom banks. Simply load in the desired presets, then save the bank to disk.

To Load a Preset:

1. From the Bank Browser, **select the bank containing the preset you wish to load** using the cursor keys, INC/DEC keys or the Data Entry Control.
2. From the Preset Browser, **select the preset you wish to load**.
3. Press the **Load** function key (F4). A pop-up window will prompt you to select the destination preset.
4. **Choose a location for the preset** using the Data Entry Control, the INC/DEC keys or the numeric keypad. You may overwrite an existing preset or choose an empty preset as the destination.
5. Press **OK** to load the selected preset or **Cancel** to cancel the operation.

View

The display can be changed to a list format instead of the normal icon-based format.

To Change the Display View:

- From the Preset Browser, press the **View** function key (F3). The screen will change to a list format. Pressing the **View** function key again toggles the view back to icon view.

Info...

Information on the selected preset can be displayed.

To Get Preset Info:

1. From the Preset Browser, press the **Info...** function key (F6). A pop up window appears with the vital statistics of the selected preset.

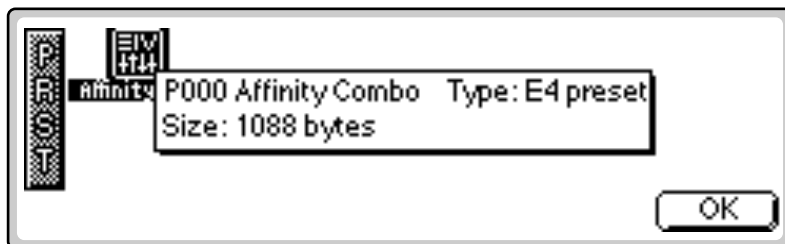

2. The preset size indicates the amount of memory that the programmable preset parameters occupy. It does not include the samples used in the preset. Press **OK** to return to the preset browser.

Sample

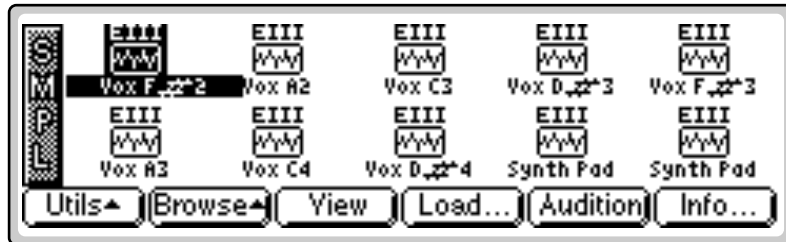

A sample is the most basic sound element of EOS and consists of the digitized sound together with truncation and looping parameters.

Sample Utilities

The Utilities menu contains several additional functions. Pressing the **Utils** function key (F1) from the Sample Browser enables a second row of function keys. Only one option is currently implemented.

Find: Allows you to search the bank for a particular sample.

Find...

This utility searches your disk library for a particular pattern of letters and numbers (a search string). If it finds the selected string anywhere in the name, the bank will be selected. Use the Find utility again to find additional matching items.

☞ To Find:

1. From the Sample Browser, press the **Utils** function key (F1).
2. Press the **Find** function key (F6). The find screen (shown on the following page) screen appears.

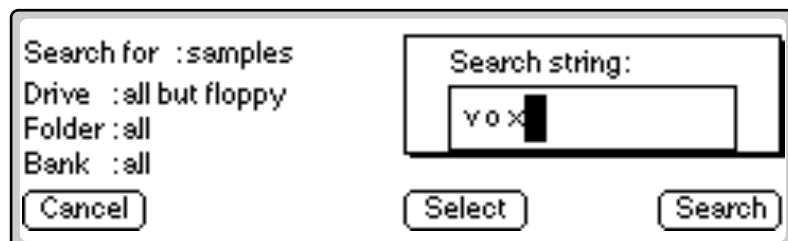

3. **Select the type of item** (folder, bank, preset, sample or sequence) you wish to search for. If you have an idea of where the item is located, you can narrow the search by inputting additional data on the drive, folder or bank. Selecting "All" tells EOS to search everything.

4. Press the **String** function key (F4), and enter the search string. Letters can be selected using the numeric pad, Data Entry Control, INC/DEC keys and cursor keys, or using an ASCII keyboard.
5. Press the **Search** function key (F6) to search for the item or **Cancel** (F1) to cancel the operation.

View

The display can be changed to a list format instead of the icon-based format.

To Change the Display View:

- From the Sample Browser, press the **View** function key (F3). The screen will change to a list format. Pressing the **View** function key again toggles the view back to icon view.

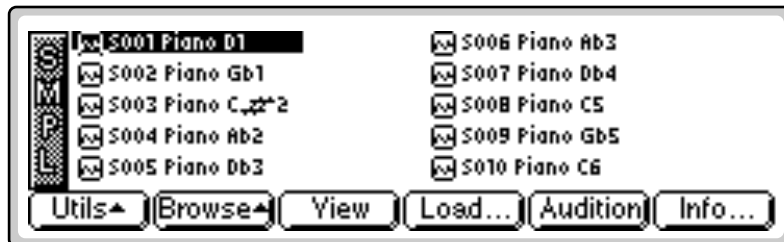

Load Sample

An individual sample can be loaded into the bank from the sample browser. This is an easy way to create your own custom presets. Simply load in the desired samples, build your preset, then save the bank to disk.

To Load a Sample:

1. From the Bank Browser, **select the bank** containing the sample you wish to load using the cursor keys, INC/DEC keys or the Data Entry Control.
2. From the **Sample Browser**, select the **Sample** you wish to load.
3. Press the **Load** function key (F4). A pop-up window will prompt you to select the destination sample.
4. **Choose a location** for the sample using the Data Entry Control, the INC/DEC keys or the numeric keypad. You may overwrite an existing sample or choose an empty sample as the destination.
5. Press **OK** to load the selected sample or **Cancel** to cancel the operation.

Load .WAV & AIFF Files

EOS can load .WAV and AIFF files from a DOS formatted floppy disk. The sample rate is included in the .WAV or AIFF header and are converted to 16 bit samples (filling in zeros if the bit size is less than 16 bits).

To Load a .WAV or AIFF Sample:

1. Insert a HD DOS formatted floppy containing the sample file.
2. Select **Drives** from the Disk Browser.
3. Select **Banks** from the Disk Browser. Each file appears as a Bank containing one Sample. Select the desired **Bank** (sample). The screen below shows a disk containing two WAVE files, an AIFF file and a MIDI sequence.



Loading samples from floppy can take a LONG time. Unfortunate, but true. It might be a good time to take a break while the sample is loading.

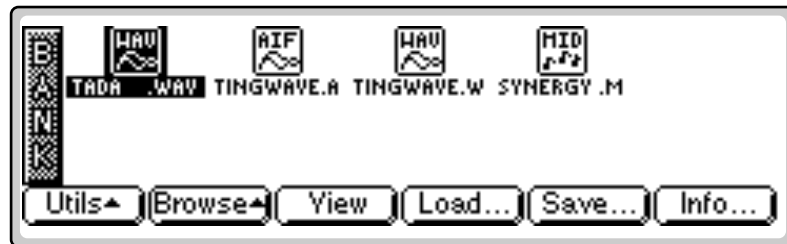

4. Select **Samples** from the Disk Browser. A single sample icon appears.
5. Press **Load** to load the sample into the current bank.

Audition

The currently selected sample can be played directly from the hard disk before loading.

To Audition a Sample:

- From the Sample Browser, press the **Audition** function key (F5). A pop up dialog box appears and the sample will be auditioned directly from the disk.

Info...

Vital information on the selected sample can be displayed.

To Get Sample Info:

1. From the Sample Browser, press the **Info...** function key (F6). A pop up window appears with information about the selected sample.
2. The window indicates: sample length, duration in seconds, the sample rate, and the loop points in samples. Press **OK** to return to the sample browser.

Sequence



Up to 50 sequences can be loaded into a bank or saved to disk as part of a bank. When you Save to disk, you are saving all presets, samples and sequences currently residing in RAM. Sequences do not appear in the Sequence Browser until you have saved the bank to disk.

Sequence Utility

The Sequence Utilities menu contains only one function — Find. Pressing the Utils function key (F1) from the Sequence Browser enables a second row of function keys.

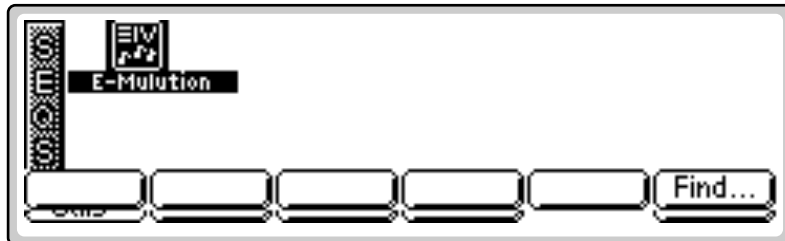

Find: Allows you to search the disk for a particular sequence.

Find...

This utility searches your disk library for a particular pattern of letters and numbers (a search string). If it finds the selected string anywhere in the name, the bank is selected. Use the Find utility again to find additional matching items.

To Find:

1. From the Sequence Browser, press the **Utilities** function key (F1).
2. Press the **Find** function key (F6). The screen shown below appears.
3. **Select the type of item** (folder, bank, preset, sample or sequence) you wish to search for. If you have an idea of where the item is located, you can narrow the search by inputting additional data on the drive, folder or bank. Selecting "All" tells EOS to search everything.
4. Press the **String** function key (F4), and enter the search string. Letters can be selected using the numeric pad, Data Entry Control, INC/DEC keys and cursor keys, or using an ASCII keyboard.
5. Press the **Search** function key (F6) to search for the item or the Cancel function key (F1) to cancel the operation.

View

The display can be changed to a list format instead of the icon-based format.

To Change the Display View:

- From the Sequence Browser, press the **View** function key (F3). The screen will change to a list format. Pressing the **View** function key again toggles the view back to icon view.

Load Sequence

An individual sequence can be loaded from another bank using the sequence browser. Simply load in the desired sequences, then save the bank to disk. Sequences can be either Emulator sequences or Standard MIDI Files. If you wish to load a sequence from another bank into the current bank perform the following steps.

To Load a Sequence from another Bank:

1. From the Disk Browser, select the **drive and bank** containing the sequence you wish to load using the cursor keys, INC/DEC keys or the Data Entry Control.
2. From the Sequence Browser, **select the sequence you wish to load.**

3. Press the **Load** function key (F4). A pop-up window will prompt you to select the destination sequence.
4. **Choose a location for the sequence** using the Data Entry Control, the INC/DEC keys or the numeric keypad. You may overwrite an existing sequence or choose an empty sequence as the destination. There are 50 possible sequence locations.
5. Press **OK** to load the selected sequence or **Cancel** to cancel the operation.

Info...

Displays information about the selected sequence.

To Get Sequence Info:

1. From the Sequence Browser, press the **Info...** function key (F6). A pop up window appears with information about the selected sequence.
2. The window indicates: sequence number, size in bytes, and type (either EIV or Standard MIDI File).

The Emulator can load and play Standard MIDI File sequences (type 0 or 1). Sequence files should conform to PC DOS format using a DOS formatted disk and using the following format for the file name: 12345678.MID (up to eight characters followed by ".MID"). It is important to note that Standard MIDI Files appear as Banks, NOT as sequences in the sequence browser.

To Load a Standard MIDI File from Floppy Disk:

1. Insert a **DOS formatted floppy disk** containing the Standard MIDI Files.
2. From the Disk Browser, **select the floppy drive**.
3. Press **Browse** again and select **Banks**. The MIDI sequences appears as banks.
4. Press the **Load** function key (F4). A pop up dialog box appears warning you that loading will destroy the resident bank.
5. Press the **Merge** key (F4). The selected sequence will be merged into the current bank, and will be placed in the first empty sequence location.
6. Press **OK** to load the selected sequence or **Cancel** to cancel the operation.

Important Information for Loading Standard MIDI Files

- Use PC DOS formatted diskettes to load from floppy. Disks can be formatted on either the Mac or PC.
- To be readable by EOS, the file **MUST** have 0-8 characters, then a period, then "MID."

Appendix

10

SCSI

SCSI (pronounced skuzzy) stands for Small Computer System Interface. SCSI is an industry standard hardware and software specification that allows high-speed data transfers between different pieces of equipment. SCSI devices can include hard disks, tape drives, optical disks and other types of digital equipment.

Why Use SCSI?

- **SCSI is fast!** SCSI is a parallel interface which transmits eight bits of information at a time at high speed over the SCSI cable. MIDI, in comparison, is a serial interface which can only send one bit of information at a time over its line.
- **Compatibility:** Since SCSI is an industry standard, equipment from many different manufacturers can be linked to work together.
- **Expandability:** Up to eight SCSI devices can be linked together (the Emulator counts as one SCSI device on the chain).

The SCSI Bus

You may have noticed that the rear panel of most external storage devices have two SCSI connectors. This is because SCSI devices are connected together in a chain arrangement. The wires that connect the different pieces of equipment are called the SCSI bus.

ID Numbers

Each device on the SCSI bus has its own ID number so that it can distinguish its data from data meant for another device. For example, if data is being saved to a device with ID-2, all the other devices on the SCSI bus will ignore that data. If two devices have the same ID number, the system will not work. Each device must have its own unique ID number.

The SCSI ID number of a Macintosh computer is fixed at ID-7 and cannot be changed. The SCSI ID numbers of most other devices can be changed.

Many SCSI devices have hardware defined ID numbers, which means that they have a switch on the front or the back of the unit which allows the ID number to be easily identified and changed.



IDE Drives: *Ultra Series Emulators can use an internal IDE hard disk. IDE drives have several advantages such as low cost, high capacity, low noise and they don't use up a precious SCSI ID number.*

- *Order IDE installation kit number 6303. This kit includes everything necessary except the IDE drive.*

The following is a list of the default SCSI ID numbers:

ID - 7	Macintosh
ID - 6	Emulator (this number can be changed)
ID - 5	Unassigned
ID - 4	Unassigned
ID - 3	Unassigned
ID - 2	Unassigned
ID - 1	Internal Emulator HD
ID - 0	Internal Macintosh HD (if installed)

Types of SCSI Cables

There are two basic types of SCSI cables in use: DB25 and 50-pin Centronics. The two types of cable can be identified by their connectors, which are quite different. When buying SCSI extension cables, it is important to choose ones with the right type of connectors, since the two types will not interconnect without a special adapter. The type of SCSI connectors on the Macintosh are DB25 connectors. These are the type commonly found on the back of personal computers. The SCSI connectors on the Emulator SCSI ports are the 50-pin Centronics type. Use only high quality shielded cables that have all the pins connected. Many cables only have some of the pins wired.

Terminating SCSI Cables

The total length of the SCSI chain should not exceed 15 feet. A general rule for SCSI cables is: The Shorter the Better, Period!

Terminating resistors or terminators are special resistor packs that are installed on the first and last device in the SCSI chain. Terminators are used to reduce line echoes or standing waves on the SCSI bus. An analogy in an audio system would be impedance matching. Terminators can either be hidden inside a SCSI device or they can take the form of termination blocks which can simply be plugged into the SCSI port.

Terminators apply power to an array of resistors to ensure a full 5 volt swing between high and low levels on the SCSI line. The host system is required to provide Termination Power. Termination power has its own wire in the SCSI cable and supplies power to the termination block. On external hard disk drives, SCSI terminator power is almost always turned Off and the drives are left unterminated.

The Emulator is shipped with termination power On and termination resistors On. This assumes that the Emulator will be placed at one end of the SCSI chain. The Emulator has an automatic system which ONLY supplies terminator power when it is NOT being supplied by another device. Therefore, you do not need to worry about terminator power when connecting the Emulator.

The termination resistors in the Emulator can be turned On or Off under software control. This function is located under Miscellaneous in the Master menu. If you have an Emulator connected in the middle of a SCSI chain (which can be done using a special SCSI "Y" cable), you would want to turn SCSI termination Off. Normally, the Emulator will be at one end of the chain and will have termination On.

The more devices you have connected to SCSI and the longer your cables are, the more it becomes important to have the cables properly terminated.

SCSI Problems

In diagnosing SCSI problems the first rule is: Don't panic, experiment! If you have several SCSI devices hooked up, first check the SCSI ID numbers, then try disconnecting one of the devices and maybe change the order of the units on the line. There are quite a number of different SCSI drives on the market each with slightly different electrical characteristics. The following checklist may help you find the solution to your unique SCSI setup.

1. Make sure the drive is mounted. Mount the drives using the Mount Drive utility (Disk, Utilities).
2. Check the SCSI ID numbers. No two numbers on the bus can be the same.
3. Read the documentation again. Learn all you can about your peripheral devices. The answer to your problem may be right in front of you.
4. Play with the order in which devices are powered up. Normally the "Big Bang" method works best (turn everything on at once), but another order may work better in your unique system. Experiment!
5. Always suspect the cable when something doesn't work on the SCSI bus. Remember: The shorter the cables are, the better.
6. Simplify the situation. Disconnect one or more drives until you get the system to work.
7. Are the ends of the SCSI bus terminated?
8. If all else fails, call us. We're here if you need us at 831-438-1921. Telephone support hours are 9:00 to 5:00 PST, Monday through Friday.



You can check the "Memory Statistics" screen when downloading samples via SMDI to keep track of how much RAM you have left.



When using Alchemy, you must add one to the sample number you want transferred.



You cannot transfer to or from sample 000 (the clipboard).

Sample Transfers Via SMDI

The Emulator can now be connected to the SCSI along with another Emulator, an ESI-32, or a personal computer. Multiple "Master" devices on the SCSI bus is not normally allowed by the standard SCSI protocol but is possible because of Emulator's advanced SCSI and SMDI (or SCSI Musical Data Interchange) implementation. Sample data can now be exchanged over the SCSI bus in a way similar to the MIDI Sample Dump Standard, except MUCH faster.

The computer should normally be positioned at one end of the chain and the Emulator at the other. The SCSI chain is properly terminated at each end by the computer and the Emulator. Devices in the middle of the chain should not have termination resistors installed.

- PC Compatibles - The Emulator has been tested with IBM PC compatible computers using the Adaptec model 1542C SCSI option card. Sound files can be transferred between a PC computer and the Emulator using Sound Forge™, Recycle™ or other sample editing software.
- Macintosh - Sound files can be transferred between a Macintosh computer and the Emulator using Recycle™, Transfer Station™, Alchemy™ or other digital sample editing software. The Emulator is able to access approved Macintosh internal CD-ROM drives with CD-ROMs containing EOS compatible files.
- The Emulator is strictly a "Slave Device" when using SMDI, meaning that it CANNOT initiate SMDI transfers. This should not normally present a problem, since a computer based editor will always have the capability to transmit and request a transfer.

Caution: A sample transferred into the Emulator will be automatically placed across the entire keyboard, overwriting the current preset's sample placement. Create a new empty preset before downloading via SMDI to avoid trashing the current preset.

Besides the raw sample data, additional information about the sample is included in a SMDI file including:

- Sample name and number (samples 1-999)
- Multichannel/Stereo/Mono status
- Sample length plus one set of loop begin/end points
- Sample rate, pitch and bit resolution
- Sample key placement (an E-mu extension to SMDI)

Using Multiple Samplers on the SCSI Bus

EOS software contains SCSI bus arbitration so that multiple “Master” devices can share the bus without a system crash. Two Emulators (EIII, ESI-32, e-64, E-IV, E4X, E-6400, E-Synth and any of the Ultra series) can share the same sound library, without having to duplicate the storage media.

When connecting your system with multiple Emulators, be sure to observe the following rules:

- NEVER try to write to two devices at the same time or write to one device while loading from another. Designate one unit as the Master which is the ONLY unit allowed to write. Turn Undo Off on all units except the Master. Simultaneous reads are OK.
- Keep SCSI cable lengths as short as possible (Under 12 feet total).
- Make sure that each SCSI device has its own unique ID number. (Remember that Emulators use up an ID number in addition to their internal hard disks.)
- Make sure the system is correctly terminated - The Emulators should be on the ends of the SCSI chain.

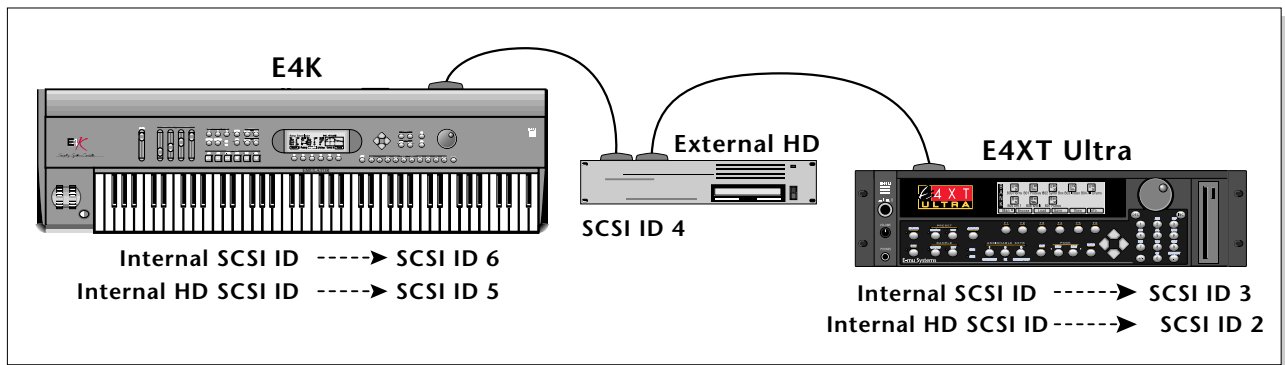

Menu Maps

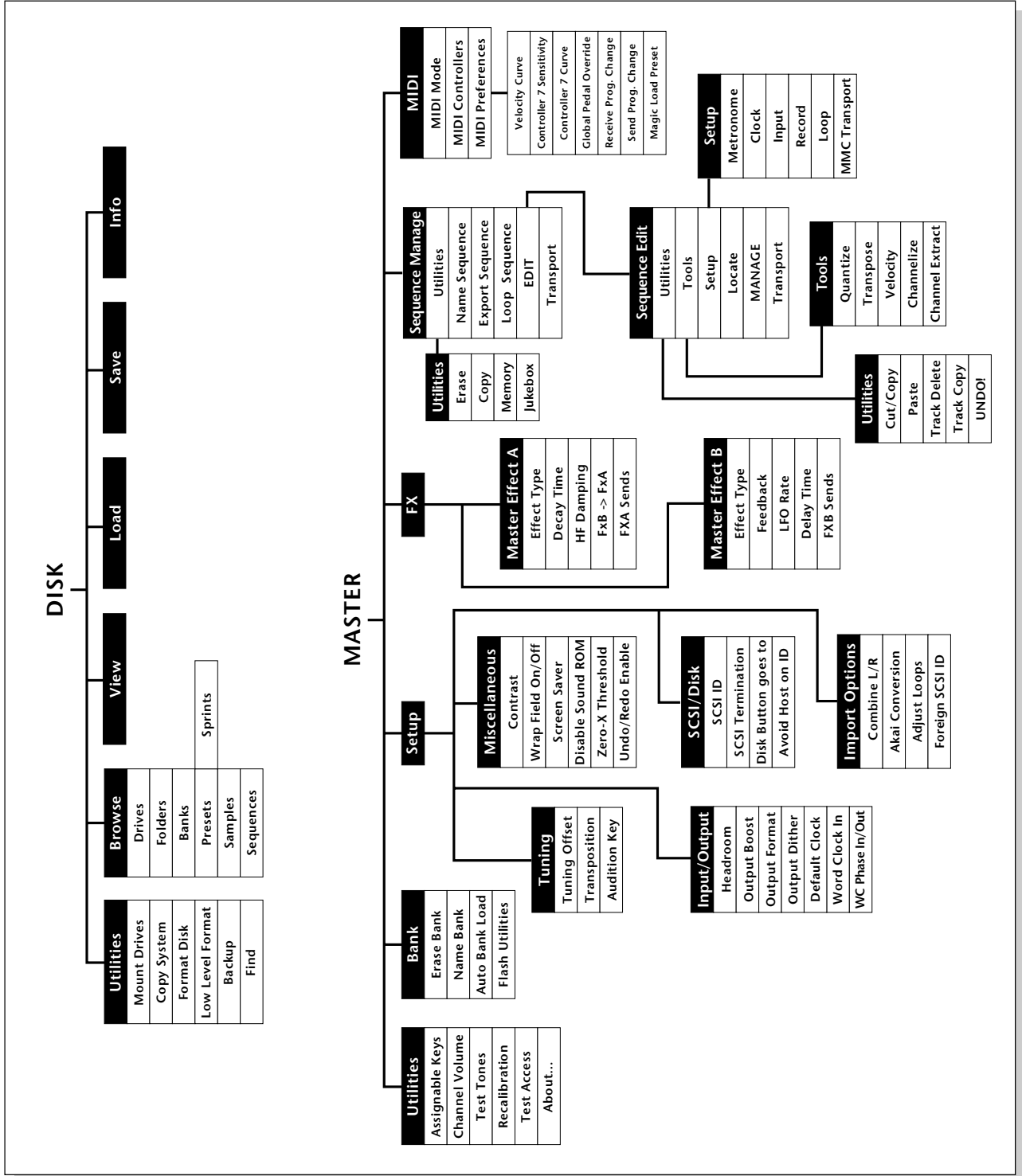

SAMPLE MANAGE

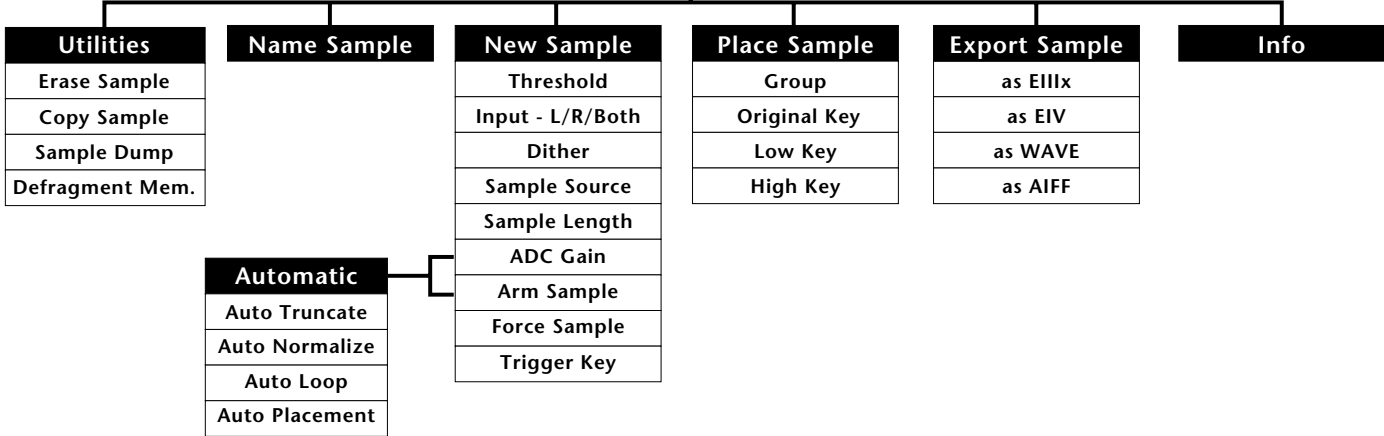

SAMPLE EDIT

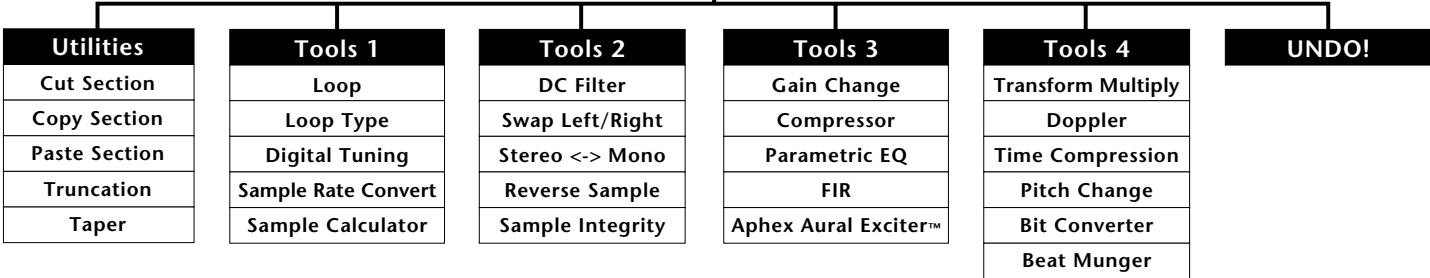

PRESET MANAGE



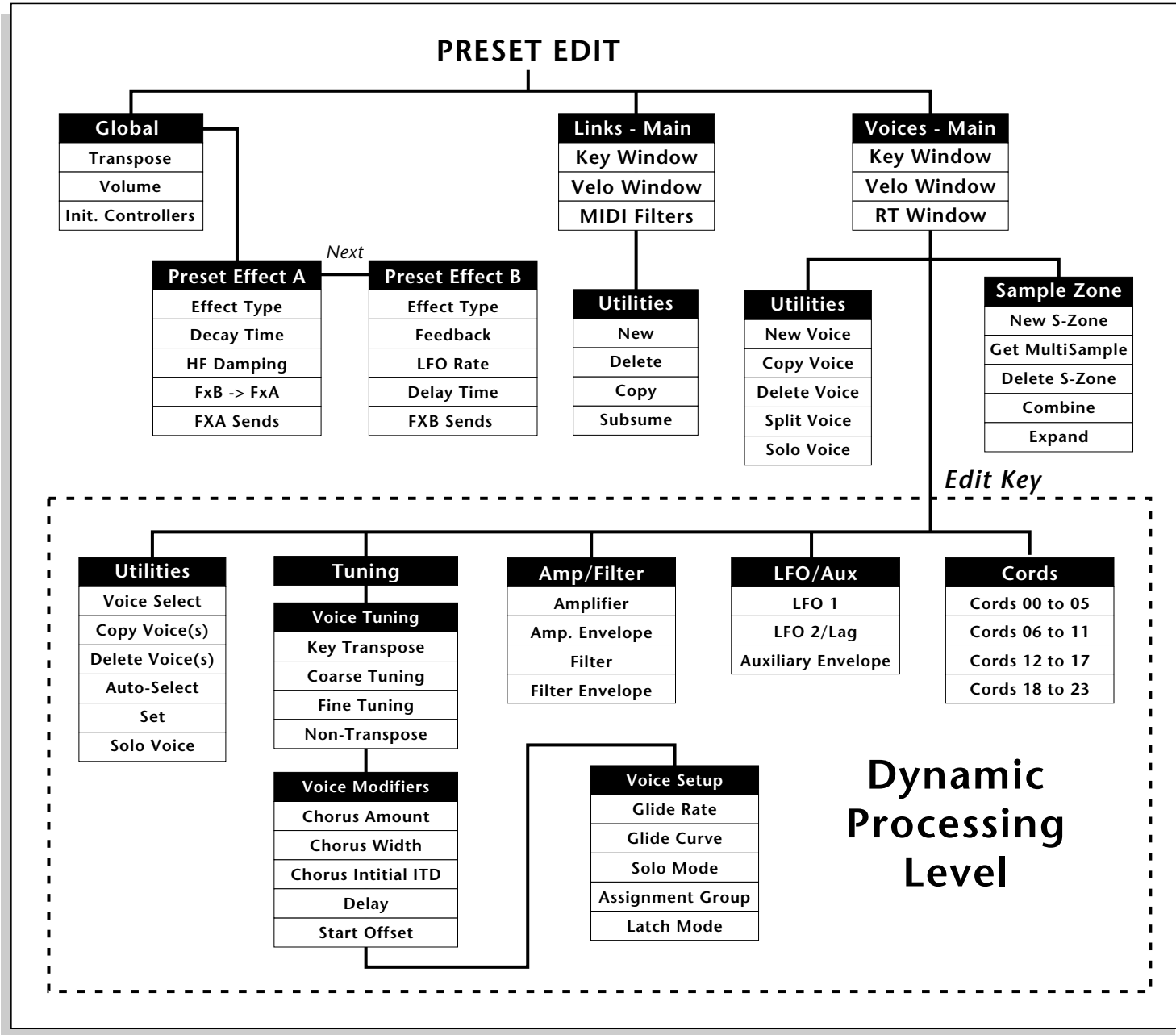

Menu Maps

MIDI

MIDI Implementation Chart

Function...	Transmitted	Recognized	Remarks
Basic Channel Default Changed	No No	1 1-16	32 with Channel Option
Mode Default Messages	No	Mode 1, 3, 4 MONO, POLY OMNI, ON/OFF	Memorized
Note Number True Voice	E4K/E-Synth Kybd E4K/E-Synth Kybd	0-127 0-127	
Velocity Note ON Note OFF	E4K/E-Synth Kybd E4K/E-Synth Kybd	Yes v=1-127 Yes	
After Touch Keys Channels	No E4K/E-Synth Kybd	No Yes	
Pitch Bender	E4K/E-Synth Kybd	Yes	
Control Change	E4K/E-Synth Kybd	Yes	0-31 64-97
Bank Select	No	Yes	
Program Change True Number	E4K/E-Synth Kybd	Yes 0-127 Yes 0-127	
All Sound Off	No	No	
All Notes Off	No	Yes	
Reset All Controllers	No	Yes	
System Exclusive	Yes	Yes	* See note below
System Common :Song Pos :Song Sel :Tune	No No No	No Yes No	
System Real Time :Clock :Commands	Yes Yes	Yes Yes	
Aux Messages :Local On/Off :Active Sense :Reset	No No No	No No No	
<p>Notes: Mode 1: OMNI ON, POLY Mode 2: OMNI ON, MONO Mode 3: OMNI OFF, POLY Mode 4: OMNI OFF, MONO</p> <p>Submix Assignments: MIDI CC #79 (0=voice, 1=main, 2=sub1...8=sub7)</p> <p>* SysEx: EOS contains an extensive MIDI SysEx implementation to support Editor/Librarian applications. Contact E-mu Systems for specifications (www.emu.com)</p>			

Notes:

Index

Symbols

.WAV export 189
.WAV files, loading 383
.WAV, save bank as 374
“A” effect types 97
“B” effect types 98

Numerics

3 way effects control 99

A

ADAT optical, sampling from 180
ADAT Output Dither 83
ADAT, optical interface 85
ADC Gain 181
Adjust Fractional Loops 94
adjusting fractional loops 93
aftertouch, mono 255
AIFF export 189
AIFF files, loading 383
AIFF, save bank as 374
Akai 4, 93
Akai Conversion 93
Akai sound 4
Akai sound libraries 4
Allpass filter 227
amp, summing 263
analog oscillator sound 335
Aphex Aural Exciter 229
Aphex, aural exciter 229
Arm Sample Trigger 182
arpeggiator 11, 12, 13
 clock 260
 octave extension 11
 sequencing 50
Arpeggiator Direction 12
Artificial Decay 197
Assign Group, voice 340
Assignable Keys 46, 66
assignable keys 46, 66
Attack Time, compressor 222
Audition 383
audition key 80
Audition, sample 383
Aural Exciter 229
Auto Bank Load 72
Auto bank load 42
Auto Correlate 209
Auto Correlation 196
auto load a bank 42, 72
auto voice selection 331
Auto/Manual voice select 326

Automatic Digital Signal Processing 184
Automatic sampling parameters 184
Automatic Voice Selection 331
automatic voice selection mode 276
Auto-sample placement 186
Auxiliary Envelope 348, 350
auxiliary envelope 324
Avoid Host on ID 91

B

Backup 364
band-pass filter 271
Bandwidth, EQ 226
Bank 41
 erase 71
bank 7, 10
 about 26
 auto load 42, 72
 erasing 46, 71
 merging 42
 name 72
 naming 46, 72
 saving 44
Bank Info 375
Bank Utilities 372
Bank, definition 26
Bank, erase 46
Bank, naming 46
Bank, saving 10, 44
banks
 loading 42
basic channel, MIDI 103
Beat Munger 237
Beat, munging 237
Bit Converter 236
BNC 85
Bookmarks 378
bookmarks, definition & use 25
boost, output 82
Browse 358
Browser 38
bus, effects 118
button
 assignment, disk 92
 thumbby 255
bypass, effects 125

C

cables, SCSI 390
calculator, sample 213
Center Frequency, EQ 226
Change Preset, in split mode 15
Changing, bit resolution of a
 sample 236
channel expander card, MIDI 107
Channel Extract, sequence track 159
channel settings in multi mode 16
Channel Volume 67

- channel volume 67
 - Channel, changing in Multimode 16
 - Channelize, sequence track 158
 - chorus 128
 - chorus amount 335
 - Chorus Amount, voice 335
 - chorus effect 288
 - Clear Flash 73
 - clipping, headroom 80
 - Clock
 - default 84
 - clock
 - arpeggiator 260
 - modulation 260
 - clock divisors 261
 - Clock Modulation 260
 - Clock source, sequencer 163
 - clock, output 84
 - coarse tuning 333
 - Coarse Tuning, voice 333
 - Comb 239
 - Combine, L/R into Stereo 93
 - Combine, voices 310
 - combining left and right into stereo 93
 - combining voices 310
 - Compact 73
 - Compact Flash 73
 - Compress Loop 209
 - Compression Ratio 222
 - Compressor, DSP 221
 - configuring memory 95
 - connecting a MAC 91
 - continuous controller 108
 - Contrast, display 86
 - contrast, LCD 86
 - controller
 - #7 110
 - curve 111
 - realtime 108
 - sensitivity 110
 - standard numbers 108
 - Controller #7 Curve 111
 - Controller #7 Sensitivity 110
 - controllers
 - about MIDI 108
 - modulation source 255
 - controllers A-H 109
 - controls, recalibrating 68
 - Copy
 - voice 305
 - copy
 - flash RAM presets to disk 33
 - flash sounds to disk 34
 - presets to flash 73
 - Copy Link 296
 - Copy Preset 248
 - Copy Sample 175
 - Copy Section, sample 201
 - Copy System 362
 - Copy Voice 305
 - Copy Voice(s) 328
 - Copy, definition 195
 - Copy, sequence 141
 - Copy, sequence track 147
 - copying voices 328
 - Cords 351
 - cords 262, 324
 - cords, modulation 256
 - Count In, sequence 165
 - Counter Display, sequence 144
 - CPU memory 29
 - CPU Meter, beat munger 239
 - credits 70
 - crossfade
 - realtime 320
 - velocity 318
 - Crossfade Looping 198
 - crossfade random 259
 - crossfade switch 280
 - crossfade voices 320
 - crossfade voices, by velocity 318
 - crossfade voices, key position 314
 - crossfade, positional 315
 - Cross-Switch, random 321
 - cross-switch, random 321
 - Cursor 37
 - cursor, about 37
 - curve 337
 - controller #7 111
 - glide 337
 - curve, velocity 110
 - Cut Section 199
 - Cut, definition 195
 - Cut, sequence track 147
- D**
- damping
 - high frequency 285
 - Data Entry Control 37
 - data entry control 37
 - recalibrate 68
 - DB25 cables 390
 - DC Filter 214
 - decay time 127
 - Default 36
 - Default Clock 84
 - default settings, about 36
 - Defragment Sample Memory 177
 - Delay
 - LFO 348
 - delay 336
 - delay effect 129, 285
 - delay time, effect 289
 - Delay Time, FX B 289
 - delay, panning 129
 - delay, stereo 129
 - Delay, voice 336
 - Delete bank 372
 - Delete folder 370

- Delete Link 296
 - Delete Voice 306
 - Delete Voice(s) 330
 - delete voices 330
 - Delete, Sample Zone 309
 - Delete, sequence track 147
 - destinations, modulation 262
 - device ID, MIDI 104
 - diagnostic tests 69
 - diagnostics 69
 - digit lock 9
 - digital signal processing 4
 - Digital Tuning, sample 211
 - diode 263
 - direction 12
 - Direction, arp 12
 - direction, arpeggiator 12
 - Disable Sound ROM 87
 - disabling sound ROM 87
 - disconnecting controllers from
 - sound 105
 - disk
 - button assignment 92
 - Disk Browser 357
 - Disk browser 38
 - disk browser, about 38
 - Disk Button Goes To 92
 - disk module
 - about 35
 - Disk Utilities 361
 - Disk, module overview 35
 - Display View 367, 375, 380, 382
 - distortion 129
 - Dither, ADAT output 83
 - Dither, input 180
 - Division, Arp. 12
 - divisors, clock 261
 - DOS floppies 363
 - DOS formatted disk 44
 - doubling 128
 - doubling (chorus) 128
 - Downbeat Selection, beat munger 238
 - Drive Info 368
 - Drive sleep 368
 - drives
 - floppy disk 27
 - internal 27
 - DSP features 5
 - dual effects processor, about 117
 - dual tap effect 129
 - Dump Preset 246
 - Duration, sequence quantize 154
 - dynamic filter 324
 - Dynamic Processing 57, 322
 - dynamic processing 278, 322
 - dynamic processing, about 57
- E**
- e 259
 - editing preset 253
 - EEPROM, reinitializing 27, 362
 - effect
 - bus 118
 - delay time 285
 - feedback amount 288
 - Effect B 287
 - Effect B Into Effect A 120
 - Effect, changing in preset 288
 - Effects
 - programmed in preset 122
 - effects 129
 - amount 285, 290
 - bypass 125
 - channel control 124
 - chorus, about 128
 - control channel, multi mode 100
 - control processor 99
 - delay 129
 - delay time 289
 - distortion 129
 - dual processor, about 117
 - dual tap 129
 - master 95, 96, 122
 - master type A 97
 - master type B 98
 - preset 122, 282
 - preset B 287
 - reverb, about 127
 - routing B into A 120
 - routing B through effect A 286
 - sends 118
 - setting global 123
 - setup 98
 - slapback 128
 - soft clipping 129
 - stereo delay 129
 - stereo flanger 128
 - submix bus 118
 - three way control 121
 - type A, about 126
 - using external 125
 - using master in multi mode 97
 - using master settings in multi mode 123
 - vibrato 129
 - effects control 99
 - effects module, about 35
 - Effects Sends 118
 - Effects Setup 98
 - Effects, enable/disable 98
 - Effects, module overview 35
 - EIII presets 366
 - EIIIx, save bank as 374
 - EIV bank, exporting sequences as 138
 - envelope
 - auxiliary 324
 - envelope generators 255
 - about 257
 - Envelope, filter 347

- EOS floppies 363
 - EOS Software backup 362
 - EOS software update 362
 - EQ, parametric 225
 - Equal Power, crossfade loop 209
 - Erase All, sequence tracks 147
 - Erase bank 71
 - Erase Notes, sequence 147
 - Erase Preset 246
 - Erase Sample 174
 - Erase sequence 140
 - erasing banks 46, 71
 - Erasing, Banks 46
 - Exciter, DSP 229
 - Expand voice 311
 - expander card, MIDI channel 107
 - expanding voices 311
 - Expansion, sample 222
 - Export
 - sample 189
 - Export Preset 249
 - Export sample 189
 - export sequence 138
- F**
- feedback amount 288
 - Feedback Amt, FX B 288
 - feedback loop 288
 - filter
 - about 270
 - band-pass 271
 - dynamic 324
 - high-pass 271
 - low-pass 269
 - notch 271
 - parametric 273
 - poles 272
 - swept EQ 273
 - Z-plane 273
 - Filter Envelope 347
 - Filter, MIDI 303
 - Filter, phase linear 227
 - Find 45
 - Find bank 373
 - Find folder 370
 - Find sample 381
 - Find sequence 385
 - fine tuning 334
 - Fine Tuning, voice 334
 - Fingered Glide
 - solo mode 338
 - FIR filter 227
 - Fix Size, loop 208
 - flange effect 288
 - flanger, stereo 128
 - Flash RAM 30
 - flash RAM 30
 - flash RAM, copying to disk 33
 - Flash Sound RAM 30
 - flash sounds, copying to disk 34
 - flash utilities 73
 - Flash, saving sequences to 136
 - Flip-Flop Footswitch 352
 - Floppy Disk, formatting 363
 - folder
 - about 26
 - Folder info 371
 - Folder Utilities 369
 - Folders, definition 26
 - footswitch modulation source 255
 - Force Sample Trigger 183
 - Foreign sampler SCSI ID 94
 - Format Disk 363
 - format, output 82
 - fractional loops, adjusting 93
 - free run 13
 - frequency
 - damping, high 285
 - frequency, high 127
 - fx
 - master 95, 96, 122
 - master type A 97
 - master type B 98
 - FX Amounts, preset 290
 - fx module
 - about 35
- G**
- Gain Change
 - sample 218
 - gain, 4x 263
 - Gain, EQ 226
 - Gain, sampling 181
 - gate modulation source 255
 - generator
 - noise 255
 - generator, envelope 255
 - generators
 - envelope 257
 - Get Info
 - sample 190
 - Get Info, preset 250
 - Get Multisample 309
 - getting started 6
 - glide
 - rate 337
 - glide curve 337
 - Glide Rate & Curve 337
 - global editing, preset 281
 - Global Editor 57
 - Global Effects 96
 - global effects settings 123
 - Global Pedal Override 111
 - global preset editor 279
 - graphic user interface 4
 - Groove 237
 - groups 277
 - Grunge 239

Guided Tours 41

H

Hard disk backup 364
 Hard Disk Drive 28
 hardware configuration display 70
 Hass-Effect 335
 Headroom 80
 headroom 80
 high frequency 127
 high frequency damping 285
 high hat simulation 340
 high-pass filter 271

I

Icons 36
 icons, about 36
 ID
 MIDI device 104
 ID Numbers, SCSI 389
 import 93
 Import Options 93
 Includes 327
 Incremental backup 365
 Initial Tempo, sequence 146
 Initial Track State 145
 Input channel, selection 179
 Input/Output 80
 instant gratification 6
 Inter-Aural Time Delay 335
 interface, gui 4
 Internal Drive 27
 inverting, mod sources 259
 Isolate Key 328
 Isolate key 326
 isolate key 328, 331
 ITD 335

J

Jukebox 142

K

key
 assignable 46, 66
 audition 80
 isolate 328
 isolate, set button 331
 transpose 79, 333
 key glide modulation source 255
 key sync 13
 Key Sync/Free Run 13
 Key Transpose, voice 333
 key velocity, modulation source 255
 Key Window
 links 298
 Key Window, voice 312
 keyboard

mode

 layer 14

 split 14

 ranges 313

 transpose 15

keyboard key, modulation source 255

Keyboard Modes 14

keyboard modes 14

keyboard pressure modulation
 source 255

Keyboard Range, voice 313

Keyboard Sample Trigger 183

L

lag processor 263

Lag Processors 349

Latch Mode 339

layer mode 14

Layer, keyboard mode 14

layering voices and samples 314

LCD contrast 86

LCD screen saver 87

LFO

 waveforms 258

LFO controls 348

LFO Rate, FX B 289

LFO sync 260

LFO syncing 260

LFOs 255

libraries 4

libraries, sound 4

Limiter, using 224

Linear, crossfade loop 209

Link

 copy 296

 delete 296

 Key Window 298

 new 295

 subsume 297

link

 creating 59

Link Fine Tuning 294

Link Pan 293

Link transpose 293

Link Utilities 295

Link, creating new 295

Links 57

Links - MIDI Filters 302

links, MIDI 291

links, preset 279

Load 42

 sequence 135

load

 bank, automatically 42

 banks automatically 72

 preset, magic 113

 sequence from different bank 43

 standard MIDI files 44

- Load Bank 366, 374
 - Load Preset 380
 - Load Sample 382
 - Load Sequence 385
 - Load sequence 43
 - Load, SMFs 136
 - Load, SoundSprint 7
 - Load, standard MIDI files 44
 - loading 7
 - Loading .WAV files 383
 - loading a 7
 - loading a bank 7
 - Loading AIFF files 383
 - Loading Standard MIDI Files 386
 - Loading, a bank 7
 - Local Control 105
 - local control 105
 - Locate point, sequence 169
 - Locate, sequencer 169
 - Lock button 9
 - lock button 9
 - Lock Drive 368
 - Lock key 9
 - Lock, digit 9
 - loop
 - adjusting fractional 93
 - feedback 288
 - Loop Compression 198
 - Loop in Release, sample 210
 - Loop Points, setting 207
 - Loop region, sequence 166
 - Loop Type, sample 210
 - Loop, beat mungers 238
 - Loop, compression 209
 - Loop, sample 207
 - looping 55
 - Looping, background 196
 - looping, grooves 237
 - low frequency oscillator 258, 324
 - low frequency oscillator rate 289
 - low frequency oscillators 255
 - Low Level Format 364
 - low-pass filter 269
- M**
- Mac on SCSI bus 91
 - Magic Load Preset 113
 - magic load preset 113
 - master
 - effects 96
 - effects type B 98
 - Master Effects 96
 - master effects 95, 122
 - Master FX, in multimode 97
 - master module
 - about 35
 - master module, about 63
 - Master, module overview 35
 - Melody
 - solo mode 338
 - memory
 - configuration 95
 - sample & preset 29
 - sound flash 32
 - Memory Configuration 95
 - Memory Full message 376
 - Memory Statistics 64
 - memory statistics 64
 - Memory types 29
 - Memory, RAM/ROM adjustment 95
 - Memory, sequence 141
 - Menu Maps 394, 395, 396
 - Menu/Transport key 143
 - merge banks 42
 - Merge, sequence track 150
 - Meter, sequencer 163
 - Metronome, beat mungers 239
 - Metronome, sequencer 48, 161
 - MIDI
 - basic channel 103
 - channel effects control 124
 - channel expander card 107
 - controller #7 110
 - controller #7 curve 111
 - controllers A-H 106
 - controllers, about 108
 - device ID 104
 - filter 303
 - links 280, 291
 - loading standard files 44
 - magic load preset 113
 - mix, multi mode 106
 - mode 103
 - mode, multi 103
 - mode, omni 103
 - mode, poly 103
 - note-on 336
 - port B 133
 - receive program change 112
 - sample dump 175
 - send program change 112
 - standard controller numbers 108
 - velocity curve 110
 - view mix 16
 - MIDI Clock Out 163
 - MIDI Controllers, overview 108
 - MIDI Filter, links 302
 - MIDI Implementation Chart 397
 - MIDI Mix 106
 - MIDI SysEx data dump 246
 - MiniMoog solo mode 338
 - MMC ID 167
 - MMC Transport 167
 - mod wheels 255
 - mode 8
 - automatic voice selection 276
 - keyboard 14
 - layer 14
 - MIDI 103

- multi 16, 103
 - multi, setting effects control
 - channel 100
 - non-transpose 334
 - normal 14
 - omni 16, 103
 - poly 16, 103
 - solo 338
 - split 14
 - using master effects setting in
 - multi 123
 - whole 14
 - modulation 253
 - clock 260
 - conds 256
 - destinations 262
 - processors 263
 - source, random 259
 - sources 255
 - modulation destination list 262, 351
 - Modulation Destinations 262
 - modulation source list 262, 351
 - modulation, about 254
 - module
 - fx 35
 - preset edit 35, 278
 - sample edit 35
 - sequencer 35
 - modules
 - about 34
 - disk 35
 - master 35
 - Modules, accessing 34
 - mono aftertouch 255
 - Mount 361
 - Mount Drives 362
 - Multi Mode 103
 - multi mode 16, 103
 - Multimode 16
 - multimode
 - using master effects 97
 - Multimode effects control channel 100
 - Multiple Samplers 393
 - Multiple Trigger
 - solo mode 338
 - multiple trigger 338
 - multisample, get 309
 - Multisample, replacing 309
 - Musical Compression 224
 - Mute, sequencer track 144
- N**
- Name bank 373
 - name bank 72
 - Name Preset 247
 - Name Sample 178
 - Name Sequence 137
 - naming
 - banks 72
 - naming a sample 55
 - Naming banks 46
 - naming banks 46
 - New
 - Sample Zone 308
 - voice 305
 - New folder 369
 - New Link 295
 - New Preset 247
 - New Sample 178
 - New Voice 305
 - noise generator 255
 - Noise Reduction 224
 - noise, white and pink 259
 - Non-transpose Mode 334
 - non-transpose mode 334
 - Normalize sample 219
 - Notch filter 227
 - notch filter 271
 - Note Erase, sequencer 148
 - Note-on modulation 262
- O**
- octave extension 11
 - Octave Extension, arp 11
 - offset, removing DC 214
 - offset, start 336
 - offset, tuning 79
 - omni mode 16, 103
 - Operating System, updating 27
 - Optical Disk, formatting 363
 - output
 - audio and digital 80
 - boost 82
 - clock 84
 - effect B into effect A processor 120
 - format 82
 - Output Boost 82
 - Output Format 82
 - Overdub, sequencer 144
 - override, pedal 111
- P**
- panning delay 129
 - Parametric Equalizer 225
 - parametric filter 273
 - Paste repeat, sequence 150
 - Paste Section, sample 202
 - Paste, definition 195
 - Paste, sequence track 150
 - patchcords 351
 - Peak mode, compressor 222
 - pedal modulation source 255
 - Pedal Override 111
 - pedal override 111
 - Phase Linear Filter 227
 - PHAT presets, creating 295
 - pink noise 259, 266

- pitch wheels 255
 - Place Sample 188
 - Points, filter 227
 - Poly Mode 16, 103
 - poly mode 16, 103
 - Port B
 - MIDI 133
 - Positional Crossfade 315
 - positional crossfade 315
 - Positional crossfade, links 299
 - preset 41
 - about 22
 - copy from floppy to flash 73
 - editing 253
 - effects 122
 - effects A 282
 - effects B 287
 - factory 31
 - flash memory 31
 - global editing 281
 - global editor 279
 - links 279
 - loading 42
 - magic load 113
 - name 247
 - receive change 112
 - send change 112
 - Preset copy 248
 - preset definition 57
 - Preset Edit
 - utilities 325
 - preset edit module 278
 - preset edit module, about 35
 - Preset Edit, dynamic processing 322
 - Preset Edit, module overview 35
 - Preset Effects 282
 - Preset Effects B 287
 - Preset Flash Memory 31
 - Preset Info 380
 - preset manage module, about 35
 - Preset Manage, module overview 35
 - Preset Memory 29
 - preset memory 29
 - preset RAM 73
 - Preset Utilities 376
 - Preset, creating new 247
 - Preset, definition 22
 - Preset, erase 246
 - preset, export 249
 - Preset, information 250
 - Preset, MIDI SysEx data dump 246
 - presets 8
 - presets, selecting 8
 - processing
 - dynamic 278, 322
 - processor, dual effects 117
 - processors
 - diode 263
 - lag 263
 - modulation 263
 - quantizer 263, 267
 - summing amp 263
 - Program change receive on/off 112
 - Program change send on/off 112
 - program change, send 112
- Q**
- Q 271
 - quantization 49
 - Quantization, sequence 49
 - Quantize input, sequence 164
 - Quantize Input, sequencer 49
 - Quantize, sequence track 154
 - quantizer 263, 267
 - quick start 6
- R**
- RAM
 - configuring memory 95
 - RAM, preset 73
 - Random cross-switch 321
 - random cross-switch 321
 - random generator 255
 - random modulation 259
 - random, crossfade 259
 - range
 - velocity 317
 - range, keyboard 313
 - rate
 - LFO 289
 - realtime controllers, about 108
 - realtime controls 319
 - realtime crossfade 320
 - Realtime crossfade, voices 320
 - realtime window, voice 319
 - recalibrate 68
 - recalibration 68
 - receive program change 112
 - Receive Program Change On/Off 112
 - Received MMC Commands 168
 - recording a sequence 47
 - Recording MIDI SysEx 136
 - Recording, sequence 47
 - redo 89
 - reference tone 67
 - Re-initialize EEPROM 27, 362
 - Release Time, compressor 222
 - release velocity modulation source 255
 - Rename folder 370
 - Repeat, sequencer paste 150
 - Replace, multisample 309
 - Re-record, sequence 144
 - Resampling 180
 - Restore, hard disk 365
 - resync 13
 - ReSync! 13
 - resync, arpeggiator 13
 - retrigger 260

- Retrigger, sample 353
 - reverb 127
 - Reverse Section, sample 216
 - RMS mode, compressor 222
 - Roland 4, 93
 - Roland sound 4
 - Roland sound libraries 4
 - Roland, Stereo Conversion 93
 - routing effect B through effect A 286
 - routing effects 120
- S**
- s 287
 - Sample
 - name 178
 - sample 41
 - about 20
 - layering 314
 - loading 42
 - memory 29
 - naming 55
 - Sample Calculator 213
 - Sample Dump 175
 - sample edit module
 - about 35
 - Sample Edit, module overview 35
 - Sample Info 383
 - Sample information 190
 - Sample Length 182
 - Sample Manage, module overview 35
 - Sample Memory 29
 - Sample memory
 - defragment 177
 - Sample monitor 184
 - Sample Numbers 31
 - Sample Rate Convert, sample 212
 - sample rate selection 180
 - Sample Retrigger 353
 - sample start 336
 - Sample Transfer, SMDI 392
 - Sample Utilities 381
 - Sample Zone 308
 - new 308
 - sample zone 308, 309
 - Sample Zone, deleting 309
 - Sample, compressor 221
 - Sample, copy 175
 - sample, creating new 178
 - Sample, DC filter 214
 - Sample, definition 20
 - sample, digital tuning 211
 - Sample, erase 174
 - Sample, gain change 218
 - Sample, layering 314
 - Sample, placement 188
 - Sample, reverse 216
 - Sample, stereo to mono 216
 - Sample, swap l/R 215
 - Sample, taper 205
 - Sample, truncate 204
 - sampling functions 178
 - Sampling Source & Rate 179
 - sampling, a practice session 53
 - Sampling, from digital inputs 180
 - Save
 - sequence 135
 - save
 - a bank to flash memory 32
 - data 36
 - Save Bank 367, 374
 - Saving 36
 - saving 10
 - saving a bank 10
 - Saving banks 10, 44
 - saving banks 44
 - screen saver 87
 - Scrub Wheel 194
 - SCSI 389
 - ID 90
 - ID, foreign sampler 94
 - MAC on bus 91
 - termination 91
 - SCSI Bus 389
 - SCSI Cables 390
 - SCSI ID 90
 - SCSI Problems 391
 - SCSI termination 390
 - SCSI Termination On/Off 91
 - SCSI/Disk 90
 - Select a Voice 327
 - Select Presets, using SoundSprint 377
 - Select, voice 326
 - selecting 8
 - selecting presets 8
 - selecting voices 276
 - selecting voices automatically 331
 - selecting, voice 326
 - send program change 112
 - sensitivity
 - MIDI controller #7 110
 - sequence
 - loading 42
 - loading from a different bank 43
 - recording a 47
 - Sequence Clock 162
 - Sequence Edit screen 143
 - Sequence Info 386
 - Sequence Input 164
 - Sequence Loop 166
 - Sequence Record 165
 - Sequence saving 135
 - Sequence undo 153
 - Sequence Utility 384
 - Sequence Velocity 157
 - Sequence, load 43
 - Sequence, naming 137
 - Sequence, recording 47

- Sequencer
 - track status 167
 - Sequencer Memory 141
 - sequencer module, about 35
 - Sequencer transport controls 139
 - Sequencer Utilities 140
 - Sequencer, module overview 35
 - sequencing, arpeggiator 50
 - set button 331
 - Set, bookmark
 - 378
 - SetSplit operation 15
 - setup
 - master effects 98
 - Shape
 - LFO 348
 - single-cycle loops 213
 - slapback 128
 - Sleep, drive data 368
 - SMDI 392
 - soft clipping effect 129
 - Software update 362
 - Software, update 27
 - Software, updating 27
 - solo mode 338
 - Solo Modes 338
 - Solo Voice 307, 331
 - solo voice 307, 331
 - Solo, sequencer track 144
 - Sound Flash 29, 75
 - Sound Flash Memory 32
 - sound flash memory 32
 - sound libraries 4
 - sound organization 19
 - Sound RAM 29
 - Sound ROM 29
 - sound ROM & sound RAM 29
 - Sound ROM, disable 87
 - sound ROM, disabling 87
 - SoundSprint 7, 8, 376
 - about 23
 - bookmarks 25
 - module, about 36
 - SoundSprint, definition 23
 - SoundSprints 7
 - sources, modulation 255
 - split keyboard 59
 - split mode 14
 - Split Point, keyboard mode 15
 - Split Voice 306
 - Split, keyboard mode 14
 - Stacked Preset, creating 295
 - Standard MIDI File 386
 - Standard MIDI files 136
 - Standard MIDI Files, load 44
 - Start Offset 336
 - start offset 336
 - stereo delay effect 129
 - stereo flanger 128
 - Stereo Width, voice chorus 335
 - stereo, combining left and right into 93
 - Stop Sampling 182
 - submix bus 118
 - Subsume Link 297
 - summing amp 263
 - Swap Left & Right 215
 - swept EQ filter 273
 - Swing, beat munger 238
 - Swing, sequence input 164
 - Swing, sequence track 154
 - switching voices 314
 - sync 13
 - Sync LFO 348
 - sync, arpeggiator 13
 - sync, LFO 260
 - Syncing, LFO to clock 260
 - Synth
 - solo mode 338
 - SysEx preset data 246
 - SysEx, recording 136
- T**
- Tap Tempo, Arp. 13
 - tap, dual 129
 - Taper, sample 205
 - tempo 12
 - Tempo Control, sequence 163
 - Tempo Control, sequencer 163
 - Tempo Display, sequence 144
 - tempo divisor 12
 - Tempo, Arp. 12
 - Tempo, beat munger 238
 - Tempo, sequence 163
 - Termination, SCSI 390
 - termination, SCSI 91
 - Test Access 69
 - test, diagnostic 69
 - thickening the sound 128
 - three way effects control 121
 - Three-way Effects Control 121
 - Threshold, compressor 222
 - Threshold, sample trigger 179
 - threshold, zero crossing 88
 - thumby button modulation source 255
 - tone, reference 67
 - Tones
 - reference 67
 - Track Copy, sequencer 152
 - Track Delete, sequencer 152
 - Track Mode, sequence 144
 - Track Numbers, sequence 144
 - Transport Controls, sequencer 139
 - Transport, sequencer 167
 - Transpose 79
 - transpose mode, non 334
 - transpose, key 333
 - transpose, keyboard in split mode 15
 - transpose, master 79
 - Transpose, sequence track 156

- Transposition 79
 - Trigger Sampling 183
 - trigger, multiple 338
 - Triplets, with Arp. 12
 - Truncate note-off 147
 - Truncate, after loop 209
 - Truncation, sample 204
 - tuning 324
 - coarse 333
 - fine 334
 - Tuning Offset 79
 - tuning offset 79
 - Tuning, master 79
 - type A effects 97
 - type B effects 98
- U**
- undo 89
 - Undo, definition 195
 - UNDO, sequencer 153
 - Undo/Redo Enable 89
 - update software 362
 - upgrade information 3
 - using external effects 125
 - Utilities
 - disk 361
 - master 65
 - utilities
 - flash 73
 - Utilities, preset edit 325
- V**
- Variation
 - LFO 348
 - Velocity Crossfade
 - Voice 318
 - velocity crossfade 318
 - Velocity Curve 110
 - velocity curve, MIDI 110
 - Velocity Range
 - voice 317
 - velocity range 317
 - Velocity range, link 301
 - Velocity Window
 - voice 316
 - Velocity window
 - links 300
 - Velocity window, links 300
 - Velocity, link 300
 - vibrato 129
 - view
 - memory statistics 64
 - Voice
 - chorus mode 335
 - copy 328
 - key window 312
 - latch mode 339
 - realtime window 319
 - velocity crossfade 318
 - voice
 - about 21
 - assign group 340
 - auto selection mode 276
 - automatic selection 331
 - coarse tuning 333
 - combine 310
 - copying 328
 - delay 336
 - deleting 330
 - expanding 311
 - fine tuning 334
 - groups 277
 - key transpose 333
 - keyboard range 313
 - layering 314
 - non-transpose 334
 - random cross-switch 321
 - selecting 326
 - selecting all 276
 - solo 307, 331
 - switching according to position 314
 - velocity range 317
 - velocity window 316
 - voice diagram 323
 - voice editor 57
 - Voice glide 337
 - Voice Select 326
 - Voice Selection, auto 331
 - Voice Utilities 305
 - Voice, delete 306, 330
 - Voice, solo 331
 - Voice, soloing 307
 - Voice, split 306
 - Voices, combining 310
 - Voices, definition 21
 - Voices, expanding 311
 - Voices, identifying 58
 - Voices, layering 314
 - Voices, realtime crossfade 320
 - Voices, switching by position 314
 - volume
 - recalibrate control 68
 - volume, channel 67
- W**
- WAVE export 189
 - waveforms
 - LFO 258
 - wheels, pitch and mod 255
 - white noise 259
 - whole mode 14
 - Whole, keyboard mode 14
 - Word Clock In 85
 - word clock phase 85
 - wrap field selection 86

Z

Zero Crossing 198
zero crossing threshold 88
zone, sample 308
Zone, selecting 326
Z-plane filter 273