



Disaster Area Designs

www.disasterareadesigns.com

DPC-4EZ Operation Manual

Firmware revision 1.01

April 2014

Thank you for purchasing the Disaster Area DPC-4EZ Pedal Controller. The DPC-4EZ is a compact effects switching system with built-in MIDI control. It is designed to switch up to four separate effects loops and to change presets on an external MIDI device simultaneously, to simplify tone changes in a live or studio setting.

CONNECTIONS:

DPC-4EZ CONNECTIONS



Connect your guitar using a 1/4" shielded instrument cable to the input. The DPC-4EZ input is unbuffered, for maximum compatibility with fuzz, wah, "vibe," and other impedance-sensitive pedals. The DPC-4EZ will work correctly if fed by a buffer or an unbuffered signal.

The next four pairs of 1/4" jacks are the sends and returns for the four effects loops. The top jacks are the return channels, and the lower jacks are the sends. In normal use, connect a cable from each send to the input of your pedals, and connect a second

cable from the output of your pedals to the corresponding returns. Each color represents one loop: blue, green, red, white.

The final jack is the main output. The DPC-4EZ may be configured to run 2x Stereo or 4 x Mono effects (default.) If stereo operation is desired, open the DPC-4EZ by removing the four screws that secure the enclosure lid. To assign the DPC-4EZ audio path to stereo, SW1 and SW2 should be UP, and SW3 should be DOWN. To configure for mono operation SW1 and SW2 should be DOWN, SW3 should be UP. Additionally, the DPC-4EZ should be set to Stereo Link mode to enable loops 1+3 / 2 + 4 to switch simultaneously. **Important note:** In stereo mode, the input and output jacks must be connected to TRS cables in order to access the second stereo channel. Input TIP feeds loops 1+2 and the output RING connector. The input RING feeds loops 3+4 and the output TIP connector. Please contact Disaster Area Designs if you have any questions regarding stereo cabling for the DPC-4EZ.

The MIDI Input and Output are described in the MIDI section below. The DPC-4EZ does not support phantom power over MIDI. The DPC-4EZ MIDI output will power some small MIDI devices such as the MIDI Solutions Quadra Thru, MIDI Merge, etc.

The USB-Mini-B jack is used for firmware update and customization. The USB jack also functions as a USB MIDI interface, and works with most computers and tablets without driver installation.

The power jack is 2.1mmID, center negative, 9V DC 64mA minimum. The DPC-4EZ may be powered by one of the standard outputs on the Voodoo Labs Pedal Power 2 Plus, or by most available power supply units. Disaster Area Designs recommends a multi-output isolated power supply for the DPC-4EZ, rather than a daisy-chained single power supply.



CONFIGURATION:

The DPC-4EZ buttons are numbered B1-B4, starting at the lower left and moving counter-clockwise. The upper-left is the mode / bank switch. The other three switches are the select switches. Throughout this document, they may be referred to as B1-B4. Holding the buttons when the DPC-4EZ boots allows you to change the way the controller operates.

Autoconfig – Hold Button 1 at boot

Hold button 1 at boot to enter Autoconfig mode. While in this mode, sending MIDI Continuous Controller (CC) 99 will set the DPC-4EZ receive channel. The value of the command received will set the MIDI channel. The Disaster Area DMC Gen2 and DPC-5 controllers will send this command at boot. Connect the DMC or DPC MIDI OUT to the DPC-4EZ MIDI IN with a standard MIDI cable. Power on the DPC-4EZ while holding Button 1, then power on the DMC or DPC controller. The DPC-4EZ will configure itself and then flash to indicate its status.

Startup Mode – Hold Button 2 at boot

Hold Button 2 to set the DPC-4EZ to start up in Preset Mode or Manual Mode. If you primarily use the controller in one mode or the other then you can set the DPC-4EZ to always start in your desired mode.

Stereo Link – Hold Button 3 at boot

Hold Button 3 to set the DPC-4EZ to Stereo Link mode. While in this mode, the DPC-4EZ loops will switch together in pairs for use with stereo effects. Loops 1+5, 2+6, 3+7 and 4+8 switch together in this mode.

MIDI Send – Hold Button 4 at boot

Hold Button 4 at boot to enable or disable MIDI sending from the DPC-4EZ. If MIDI sending is enabled, MIDI commands will be sent when selecting a preset, turning loops on and off, or enabling the mute. If MIDI sending is disabled, the DPC-4EZ MIDI input and output still function, but the output only serves as a MIDI “thru,” to pass data from the input to the output. Disable MIDI sending if you are using a master MIDI controller with the DPC-4EZ.

Reset Presets and Configuration

Hold Buttons 4 + 1 to reset all parameters to their defaults. This will also overwrite all presets.

Hold Buttons 2 + 1 to enter firmware update mode. In this mode the DPC-4EZ will operate as a USB serial port for firmware update.

Using the DPC-4EZ

PRESET MODES:

The DPC-4EZ has the ability to engage multiple bypass loops and a MIDI program with a single tap. This collection of settings is called a “preset.” If you prefer to control your loops manually, the DPC-4EZ may be set to start up in the manual mode and the preset modes may be safely ignored.

The DPC-4EZ has three presets per bank, with four banks for a total of twelve (12) presets accessible from the DPC-4EZ itself. 128 presets may be saved and accessed by using an external MIDI controller.

The current preset bank may be selected by tapping button B4 to cycle through the red, green, blue, or violet modes.

To select a preset, press any select button B1-B3 while the DPC-4EZ is in the red, green, blue, or violet preset mode. Pressing the currently selected preset puts the DPC-4EZ into its bypass state. The bypass state may be set up as an additional preset or “favorite” sound.

MANUAL MODE:

To enter manual mode, simply hold the bank button (B4) until its LED turns either OFF or WHITE. Tap buttons 1-4 to select the loops. The LED colors match the loop jack colors – Loop 1 blue, Loop 2 green, Loop 3 red, and Loop 4 is white.

To save the currently selected loops to a preset, press-hold B3 to store. The bank LED will begin flashing red. Tap B4 to select the destination bank (red, green, blue, or violet.) Once the bank has been selected, press-hold any button B1-B3 to save the preset to that location.

Tapping B1 while the bank LED is flashing sets the loop status to “don’t care.” In this mode, selecting this preset will not change the status of the loops. This can be used to send a MIDI change to a connected device without affecting the non-MIDI pedals. The DPC-4EZ will indicate “don’t care” mode by flashing the blue LED above B1. Save the preset while the LED is flashing to assign “don’t care” to that location.

If a MIDI controller is connected to the DPC-4EZ MIDI input, the DPC-4EZ can “learn” an incoming MIDI program change to save a preset. Enable the loops for the preset, then hold B3 to enter store mode. Optionally, tap B1 to assign “don’t care” if desired, and then send a MIDI program change from your MIDI controller. The DPC-4EZ will flash to indicate the preset has been saved. Sending MIDI program change 0 will set the “bypass” preset.

MIDI:

The DPC-4EZ features both DIN (5-pin) MIDI and USB MIDI. The two interfaces work at the same time and are bridged together. Sending a MIDI message into the DIN port will transfer the message to both the DIN output and to a connected computer or tablet using the USB port. Likewise, an application running on a connected computer or tablet can control the DPC-4EZ or send messages to a connected device through the DIN output port. Please visit disasterareadesigns.com for video examples of the USB MIDI connectivity.

The DPC-4EZ responds to MIDI Program Change (PC) and MIDI Continuous Controller (CC) messages. Program Change messages will engage the presets or the bypass setting on the DPC-4EZ. Continuous Controller messages may be used to change the status of the DPC-4EZ loops or to store a preset. Please consult the MIDI implementation chart for details of specific commands that the DPC-4EZ will accept.

Recalling a preset on the DPC-4EZ will send a MIDI Program Change message. Engaging the bypass preset will send Program Change 0, the red preset bank sends Program Changes 1-3; the green preset bank sends Program Changes 4-6, etc.

When the DPC-4EZ receives a program change message, the loops will change state to match the preset saved in that location. If the DPC-4EZ receives a MIDI program change higher than 12, the bank LED will turn off. If the DPC-4EZ is in manual mode when it receives a MIDI program change message, its LEDs will update to show the current status of its loops.

Engaging a loop in manual mode sends a MIDI Continuous Controller message. If MIDI SEND is set to OFF in the power-on configuration, then neither Program Change nor Continuous Controller messages will be sent by the DPC-4EZ. The MIDI input and output still function and pass messages through whether MIDI SEND is enabled or not, as is the USB MIDI functionality.

MIDI IMPLEMENTATION CHART

THE DPC-4EZ RESPONDS TO THE FOLLOWING MIDI MESSAGES

Function	Controller	Value	Notes
Loop 1	CC50	0-63 BYPASS, 64-127 ENGAGE	
Loop 2	CC51	0-63 BYPASS, 64-127 ENGAGE	
Loop 3	CC52	0-63 BYPASS, 64-127 ENGAGE	
Loop 4	CC53	0-63 BYPASS, 64-127 ENGAGE	
Save Preset	CC122	0-127	Value is number of preset to save. Saves current status of Loops 1-4.
Load Preset	Program Change	0-127	Program 0 is "bypass." Programs 1-12 are accessible from DPC-4EZ itself Programs 0-127 are accessible from external MIDI controller

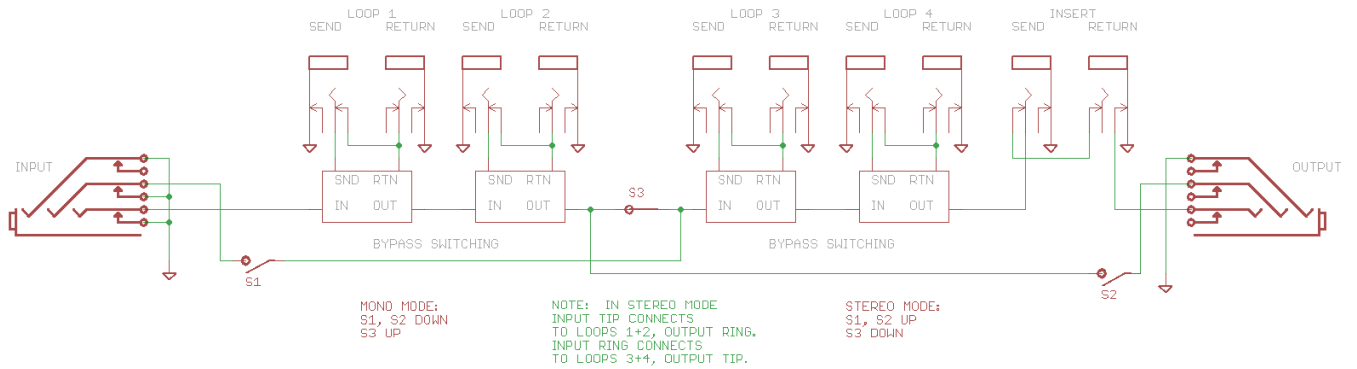

DPC-4EZ Block Diagram

DPC-4EZ QUICK REFERENCE GUIDE

DISASTER AREA DESIGNS LLC

DPC-4EZ FUNCTIONS
 REV 1.01
 140421

HOLD AT POWER ON
 FOR FACTORY RESET

PRESET MODE BANK SELECT
 HOLD FOR EDIT MODE

EDIT MODE LOOP 4 (WHITE)
 HOLD FOR PRESET MODE

SAVE MODE BANK SELECT
 HOLD TO EXIT

POWER ON CONFIG HOLD FOR MIDI SEND

PRESET MODE PRESET A

EDIT MODE LOOP 1 (BLUE)

SAVE MODE HOLD SAVE A
 TAP "DON'T CARE"

POWER ON CONFIG HOLD FOR MIDI CHANNEL
 LEARN MODE

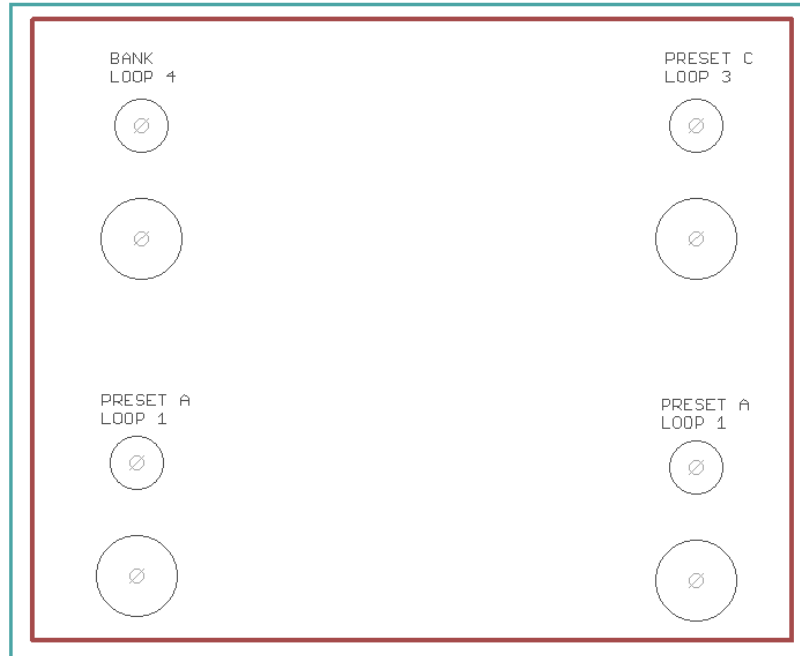

PRESET MODE PRESET C

EDIT MODE LOOP 3 (RED)

SAVE MODE HOLD SAVE C

POWER ON CONFIG HOLD FOR STEREO LINK

PRESET MODE PRESET B

EDIT MODE LOOP 2 (GREEN)

SAVE MODE HOLD SAVE B

POWER ON CONFIG HOLD FOR BANK vs PRESET
 STARTUP MODE

HOLD AT POWER ON
 FOR UPDATE MODE