

# ULTRAMIZER PRO DSP1424P

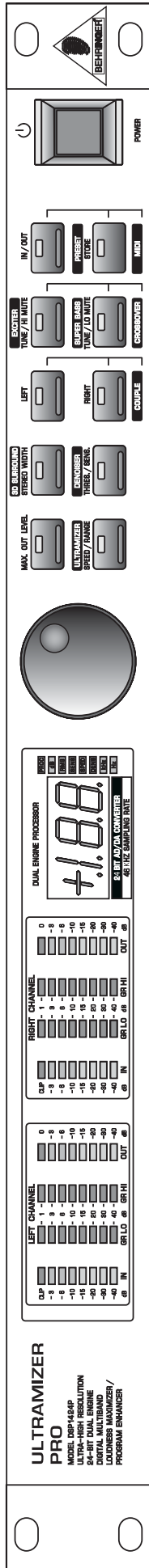

**ULTRAMIZER PRO**  
 14 BIT DSP  
 ULTRA-HIGH RESOLUTION  
 84-BIT DUAL ENGINE  
 DIGITAL MULTIBAND  
 COMPRESSION /  
 PROGRAM ENHANCER

## User's Manual

Version 1.0 September 2002

ENGLISH



[www.behringer.com](http://www.behringer.com)

# ULTRAMIZER PRO DSP1424P

## SAFETY INSTRUCTIONS

**CAUTION:** To reduce the risk of electric shock, do not remove the cover (or back). No user serviceable parts inside; refer servicing to qualified personnel.

**WARNING:** To reduce the risk of fire or electric shock, do not expose this device to rain or moisture.



This symbol, wherever it appears, alerts you to the presence of uninsulated dangerous voltage inside the enclosure—voltage that may be sufficient to constitute a risk of shock.



This symbol, wherever it appears, alerts you to important operating and maintenance instructions in the accompanying literature. Read the manual.

### DETAILED SAFETY INSTRUCTIONS:

All the safety and operation instructions should be read before the device is operated.

#### **Retain Instructions:**

The safety and operating instructions should be retained for future reference.

#### **Heed Warnings:**

All warnings on the device and in the operating instructions should be adhered to.

#### **Follow instructions:**

All operation and user instructions should be followed.

#### **Water and Moisture:**

The device should not be used near water (e.g. near a bathtub, washbowl, kitchen sink, laundry tub, in a wet basement, or near a swimming pool etc.).

#### **Ventilation:**

The device should be situated so that its location or position does not interfere with its proper ventilation. For example, the device should not be situated on a bed, sofa, rug, or similar surface that may block the ventilation openings, or placed in a built-in installation, such as a bookcase or cabinet that may impede the flow of air through the ventilation openings.

#### **Heat:**

The device should be situated away from heat sources such as radiators, heat registers, stoves, or other devices (including amplifiers) that produce heat.

#### **Power Source:**

The device should be connected to a power supply only of the type described in the operating instructions or as marked on the device.

#### **Grounding or Polarization:**

Precautions should be taken so that the grounding or polarization means of an device is not defeated.

#### **Power-Cord Protection:**

Power cords should be routed so that they are not likely to be walked on or pinched by items placed upon or against them, paying particular attention to cords and plugs, sockets, outlets and the point where they exit from the device.

#### **Cleaning:**

The device should be cleaned only as recommended by the manufacturer.

#### **Non-use Periods:**

The power cord of the device should be unplugged from the outlet when left unused for a long period of time.

#### **Debris and Liquid Entry:**

Debris and/or liquids should not be allowed to enter the enclosure through openings.

#### **Damage Requiring Service:**

The device should be serviced by qualified service personnel when:

- The power supply cord or the plug has been damaged; or
- Debris or liquid has entered the device; or
- The device has been exposed to rain; or
- The device does not appear to operate normally or exhibits a marked change in performance; or
- The device has been dropped, or the enclosure damaged.

#### **Servicing:**

The user should not attempt to service the device beyond that which is described in the operating instructions. All other servicing should be referred to qualified service personnel.

## FOREWORD

Dear Customer,

Welcome to the team of ULTRAMIZER PRO users and thank you very much for expressing your confidence in BEHRINGER products by purchasing this unit.

It is one of my most pleasant tasks to write this letter to you, because it is the culmination of many months of hard work delivered by our engineering team to reach a very ambitious goal: making an outstanding device that will become a standard tool used by studios and P.A. companies. The task to design the ULTRAMIZER PRO certainly meant a great deal of responsibility, which we assumed by focusing on you, the discerning user and musician. It also meant a lot of work and night shifts to accomplish this goal. But it was fun, too. Developing a product usually brings a lot of people together, and what a great feeling it is when everybody who participated in such a project can be proud of what we've achieved.

It is our philosophy to share our joy with you, because you are the most important member of the BEHRINGER family. With your highly competent suggestions for new products you've greatly contributed to shaping our company and making it successful. In return, we guarantee you uncompromising quality (manufactured under ISO9000 certified management system) as well as excellent technical and audio properties at an extremely favorable price. All of this will enable you to fully unfold your creativity without being hampered by budget constraints.

We are often asked how we can make it to produce such high-grade devices at such unbelievably low prices. The answer is quite simple: it's you, our customers! Many satisfied customers means large sales volumes enabling us to get better conditions of purchase for components, etc. Isn't it only fair to pass this benefit back to you? Because we know that your success is our success, too!

I would like to thank all people whose help on "Project ULTRAMIZER PRO" has made it all possible. Everybody has made very personal contributions, starting from the designers of the unit via the many staff members in our company to you, the user of BEHRINGER products.

My friends, it's been worth the trouble!

Thank you very much,

A handwritten signature in black ink, appearing to read 'U. Behringer', with a long horizontal flourish extending to the right.

Uli Behringer

# ULTRAMIZER PRO DSP1424P

## ULTRAMIZER PRO DSP1424P

Ultra high-performance digital multiband loudness maximizer / sound program enhancer powered by a 24-bit DSP

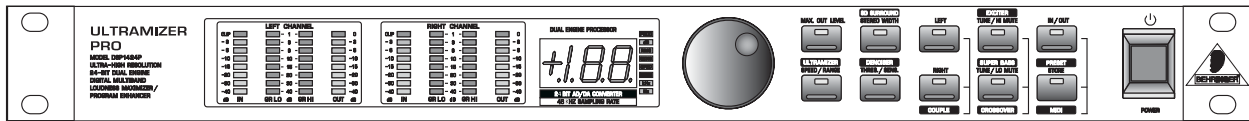

- ▲ Doubles the loudness of your recordings and sound reinforcement systems without any distortion
- ▲ Ultimate mastering machine maximizes signal energy with absolutely “inaudible” and transparent compression
- ▲ Variable band-split compression eliminates virtually any gain intermodulation effects, such as “bass pumping” etc.
- ▲ Multiband “brickwall” limiter protects against any clipping and dangerous sound pressure levels
- ▲ Built-in denoiser and exciter for noise-free and ultra transparent sound
- ▲ 3D stereo surround processor provides unbelievable spatial enhancement and improved stereo imaging
- ▲ Super bass enhancer psycho-acoustically creates an incredible bass sound below your loudspeaker’s frequency range
- ▲ Incorporated leveler for constant average output level while retaining the instantaneous dynamics
- ▲ Free ULTRAMIZER software allows total remote control via PC—download at [www.behringer.com](http://www.behringer.com)
- ▲ 24-bit A/D and D/A converters with 64/128 times oversampling for ultra-high headroom and resolution
- ▲ Internal 24-bit processing with professional 46 kHz sampling rate
- ▲ Servo-balanced inputs and outputs on gold-plated XLR and TRS connectors for high signal integrity
- ▲ 50 programmable user presets for instant recall
- ▲ Accurate eight-segment LED level and gain reduction meters for optimum performance
- ▲ “Future-proof” software-upgradeable architecture
- ▲ Full MIDI capability allows real-time parameter control and program selection
- ▲ High-quality components and exceptionally rugged construction ensures long life and durability
- ▲ Manufactured under ISO9000 certified management system

## TABLE OF CONTENTS

<b>1. INTRODUCTION .....</b>	<b>6</b>
1.1 The design concept .....	6
1.2 Before you begin .....	6
1.3 Control elements .....	7
1.3.1 Front panel .....	7
1.3.2 Back panel .....	10
1.3.3 Restoring factory defaults .....	10
<b>2. OPERATION .....</b>	<b>10</b>
2.1.1 The Ultramizer function .....	11
2.1.2 The Max. Out Level function .....	11
2.1.3 The Exciter function .....	12
2.1.4 The Super Bass function .....	12
2.1.5 The 3D Surround function .....	12
2.1.6 The Denoiser function .....	12
2.1.7 The Crossover parameter .....	13
2.2 Selecting presets .....	13
2.3 Editing presets .....	13
2.4 Saving presets .....	13
2.5 MIDI control .....	14
<b>3. APPLICATIONS .....</b>	<b>15</b>
3.1 Level setting .....	15
3.2 Using the ULTRAMIZER PRO in a studio environment .....	15
3.2.1 The ULTRAMIZER PRO in analog recording .....	16
3.2.2 The ULTRAMIZER PRO in digital recording and sampling .....	16
3.2.3 The ULTRAMIZER PRO in mastering .....	16
3.3 The ULTRAMIZER PRO as a protective device .....	17
3.3.1 Protection of a system with a passive crossover .....	17
3.3.2 Protection of a system with an active crossover .....	18
3.3.3 Improving the sound of a processor system .....	18
3.4 The ULTRAMIZER PRO in combination with a multitrack .....	18
3.5 The ULTRAMIZER PRO in broadcast .....	18
3.5.1 AM/TV broadcasting .....	19
3.5.2 Telephone lines and wireless systems .....	19
3.6 Using the ULTRAMIZER PRO on inserts .....	19
3.7 The ULTRAMIZER PRO in a MIDI setup .....	20
3.8 Saving data via MIDI .....	20
<b>4. INSTALLATION .....</b>	<b>21</b>
4.1 Rack mounting .....	21
4.2 Mains connection .....	21
4.3 Audio connections .....	21
<b>5. APPENDIX .....</b>	<b>23</b>
5.1 MIDI implementation .....	23
<b>6. SPECIFICATIONS .....</b>	<b>24</b>
<b>7. WARRANTY .....</b>	<b>25</b>

# ULTRAMIZER PRO DSP1424P

---

## 1. INTRODUCTION

The BEHRINGER ULTRAMIZER PRO is a digital sound processing device based on a sophisticated DSP, using 24 bit A/D and D/A converters. The high speed DSP is capable of performing the calculations needed for the complex algorithms in fractions of a second, the only element affecting its performance being the software. Despite extensive computing work which is done in the DSP1424P by a “dual-engine” 24-bit processor, the ULTRAMIZER PRO can be operated easily and conveniently. All parameter edits are performed with the jog wheel (rotary control). 50 presets are available to store user-defined programs.

 **The following operational manual will introduce you to the BEHRINGER ULTRAMIZER PRO and its various functions. After reading the manual carefully, make sure it is always on hand for future reference.**

### 1.1 The design concept

Contrary to analog technique, which has a limited response time capability, digital technology can look ahead to anticipate changes in incoming signals. The longer the look ahead, the more “intelligent” the response of the device or algorithm used.

You probably have heard a voice or solo instrument “disappearing” after a strong bass drum or bass line. This is a typical problem experienced by virtually every compressor. The level of a sound signal is mostly determined by the bass signals. When the bass rises above the set threshold value of the compressor/limiter, the unit will reduce the gain, which is another way of saying that the overall level will be reduced to prevent the signal from becoming too strong. With that reduction in level, all other components like voices and instruments will also be reduced in level, making the sound muddy and dull.

This “drowning out” of voices and other instruments can be avoided if the frequency spectrum is divided in two parts. Each section can then be compressed or limited individually. The signals from the different compressors are then added up again to make up the complete spectrum again.

The ULTRAMIZER PRO divides the spectrum into two bands prior to performing the dynamic functions. This enables a very musical and effective compression of the program material signal. On top of that, the ULTRAMIZER PRO also features a highly effective denoiser, an accurate and fast peak limiter, a 3D surround processor and a new super bass/exciter for both low and high frequencies.

The philosophy behind BEHRINGER products guarantees a no-compromise circuit design and employs the best choice of components. Top-quality 24-bit AD/DA converters which belong to the best components available owing to its outstanding specifications and excellent sonic characteristics. A 24-bit DSP is used as the heart of the ULTRAMIZER PRO. It performs the precise calculations needed for the processing of the complex algorithms. Additionally, the DSP1424P uses resistors and capacitors with very tight tolerances, high-grade switches, low-noise operational amplifiers (type 4580) as well as other selected components

The ULTRAMIZER PRO uses SMD technology (Surface Mounted Device). These subminiature components adapted from aerospace technology allow for an extreme packing density, improving the unit’s reliability even further. Additionally, the unit is manufactured under ISO9000 certified management system.

### 1.2 Before you begin

Your BEHRINGER ULTRAMIZER PRO was carefully packed in the factory and the packaging was designed to protect the unit from rough handling. Nevertheless, we recommend that you carefully examine the packaging and its contents for any signs of physical damage, which may have occurred in transit.

 **If the unit is damaged, please do not return it to us, but notify your dealer and the shipping company immediately, otherwise claims for damage or replacement may not be granted. Shipping claims must be made by the consignee.**

The BEHRINGER ULTRAMIZER PRO fits into one standard 19" rack unit of space (1 3/4"). Please allow at least an additional 4" depth for the connectors on the back panel.

 **Be sure that there is enough space around the unit for cooling and please do not place the ULTRAMIZER PRO on high temperature devices such as power amplifiers etc. to avoid overheating.**

# ULTRAMIZER PRO DSP1424P

The mains connection of the ULTRAMIZER PRO is made by using the supplied cable. It meets all of the international safety certification requirements. Please make sure that all units have a proper ground connection.

**Before you connect your ULTRAMIZER PRO to the mains, please make sure that your local voltage matches the voltage required by the unit (see chapter 6 “SPECIFICATIONS” for details)!**

As a standard the audio inputs and outputs on the BEHRINGER ULTRAMIZER PRO are fully balanced. If possible, connect the unit to other devices in a balanced configuration to allow for maximum interference immunity. The automatic servo function detects unbalanced connections and compensates the level difference automatically (6 dB correction).

The MIDI links (IN/OUT/THRU) are made over standardized DIN patch cords. The data communication is isolated from ground by an opto-coupler.

## 1.3 Control elements

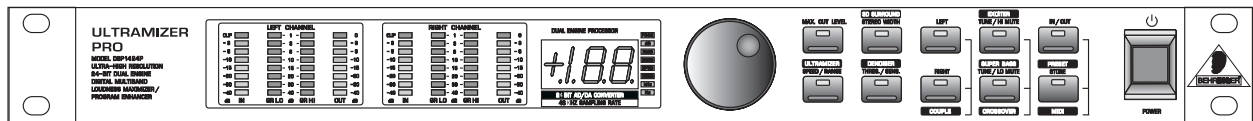

Fig. 1.1: ULTRAMIZER PRO front panel

The BEHRINGER ULTRAMIZER PRO is equipped with ten illuminated parameter keys, one jog wheel (rotary control), a numeric display, 8 LED indicators and a power switch. Each of the two fully independent channels can be monitored with four 8-stage LED meters, displaying input level, output level and gain reduction for both bands.

### 1.3.1 Front panel

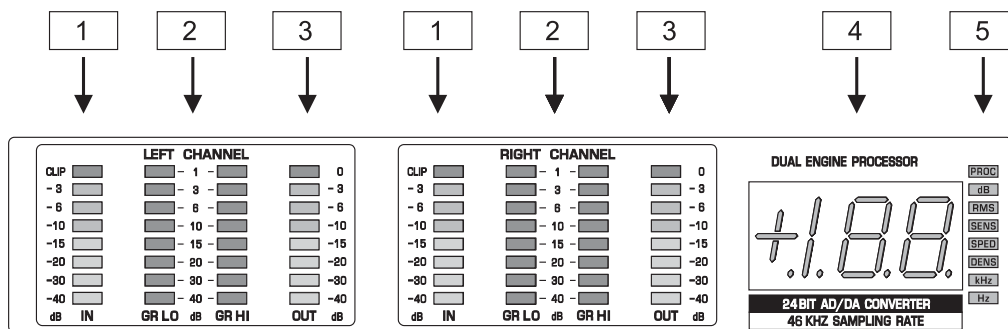

Fig. 1.2: Display section DSP1424P

- 1 The two LED chains read the input signal level in dB, referenced to the internal digital maximum.
- Please note that the nominal level of the ULTRAMIZER PRO should be selected with the +4 dBu / -10 dBV switch located on the back panel (see chapter 3.1).**
- 2 The gain reduction meters show the applied gain reduction. Gain reduction is shown for both frequency bands. GR LO shows the gain reduction in the lower and GR HI in the higher frequency band.
- 3 These two OUT LED chains read the output signal level in dB, referenced to the maximum output level of +15 dBu.
- 4 After power-up, the LED display reads the number of the preset last used. This clearly legible, 2½ digit numeric display has plus/minus indicators to show that parameters are being incremented or decremented in edit mode.



# ULTRAMIZER PRO DSP1424P

- 5] Next to the display, the appropriate unit lights up to indicate the correct value which is being edited. These eight LED illuminated units are very important with keys which can represent more than one parameter.

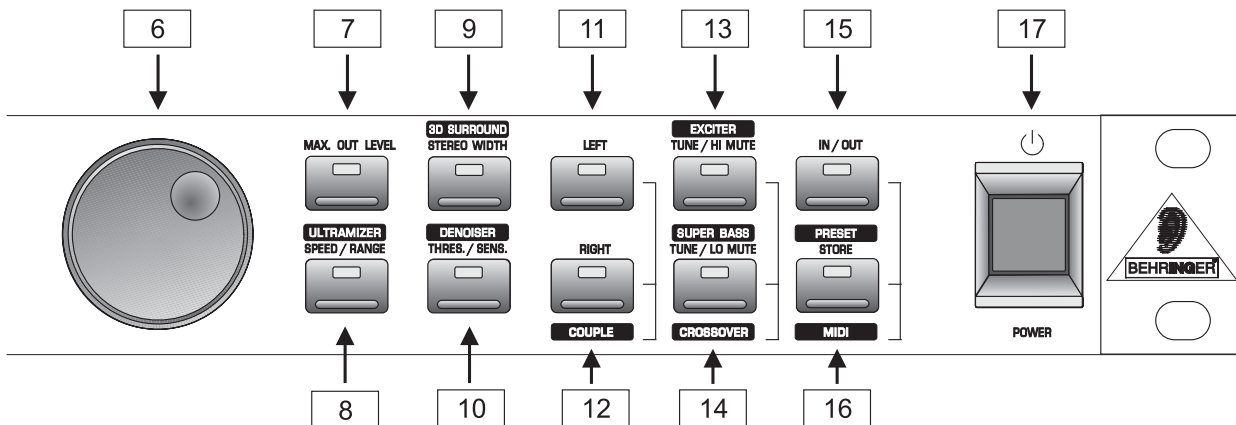



Fig. 1.3: Function keys and jog wheel

- 6] With the *jog wheel*, a continuous rotary control, you can freely edit the selected parameters. Turn the wheel clockwise to increase the values or counterclockwise to reduce them.

 **When you press the PRESET key once, you can use the wheel to select a program directly, which is shown by a dot lighting up in the display. While this dot is on, you can select a program though its settings will not take immediate effect. When the jog wheel has not been touched for a short time, the LED in the display disappears and the program is loaded.**

- 7] Use the *MAX. OUT LEVEL* to set the output limiter. This value can be set from -48 to 0 dB. The dB value will light up next to the numeric display. You can change the *MAX. OUT LEVEL* parameter from peak to RMS mode by pressing the *MAX. OUT LEVEL* key for about 2 seconds. RMS means the setting of an average level for the *MAX. OUT LEVEL* parameter. Peak stands for a peak value. To make clear that you are in RMS mode “RMS” will light up in the display.

- 8] The Ultramizer function enables you to maximize the perceived loudness of the program material. The *ULTRAMIZER* key gives you access to three parameters:

a) When pressed once the *DENSITY* (“DENS” will light up in the display) can be adjusted. The subjectively felt density of the program material is the result of the amount of compression that is applied. The *DENSITY* can be adjusted from 0 (no compression) to 100 (extreme dynamic gain reduction).

b) Pressed a second time, the *SPEED* of the Ultramizer function can be set (“SPED” will light up in the display). This parameter is very important for the dynamic behavior which depends on the application. Generally low *SPEED* settings are suited if the *ULTRAMIZER* is to work rather “inaudibly”. Higher *SPEED* is required when short level changes should be levelled.

c) Pressed a third time, the *RANGE* can be set (“dB” will light up in the display). This parameter determines the maximum amplification the Ultramizer function may use in order to achieve the desired *DENSITY* and *MAXIMUM OUTPUT LEVEL*. The value can be adjusted from 0 to 24 dB.

For further information on the Ultramizer function please refer to section 2.1.1.

- 9] Use the *3D SURROUND* key to increase the stereo width of the signal. The settings can range from 0 (no processing) to 100.

- 10] The *DENOISER* key gives you access to two parameters which influence the process.

a) When pressed once, the *THRESHOLD* of the noise gate can be set (“dB” will light up in the display). The value ranges from -90 to 0 dB. “OF” means the denoiser function is deactivated.

 **Please bear in mind that when the threshold number displayed is small, the threshold level in fact is high and, consequently, only loud signals will pass. When, for example, the value is lowered to -100 dB (referring to the digital maximum) every signal will pass.**



# ULTRAMIZER PRO DSP1424P

b) When pressed a second time the *SENSITIVITY* can be adjusted (“SENS” will light up in the display). This governs the sensitivity of the dynamic high cut filter and how it reacts to the input signal. The value ranges from 0 to 100.

11] When the *LEFT* key is pressed only the settings for the left channel are edited.

12] Use the *RIGHT* key to select the right audio channel.



**If you wish to process the left and right audio channels simultaneously (*COUPLE* mode), press both *LEFT* & *RIGHT* keys together. In couple mode both key LEDs light up. Whenever you edit one of the two audio channels and then switch to couple mode, the parameters of the active channel will be copied to the other; i.e. if you press *LEFT* before *RIGHT*, left will be copied to right.**

13] The *EXCITER* key has three functions:

a) *PROCESS*, (“PROC” will light up) when pressed once the intensity of the exciter function can be adjusted ranging from 0 to 100.

b) Pressed a second time the *TUNE* parameter can be set (“kHz” will light up). The *TUNE* control sets the lower cut-off frequency of the exciter function. The cut-off frequency can be adjusted within a range of 4 to 12 kHz.

c) The third function is reached by pressing the *EXCITER* key for more than 2 seconds. The upper frequency band is then muted. This is indicated by a full LED bar that flashes on and off (GR HI). This function is useful when you want to monitor the processing of the ULTRAMIZER PRO. Alternatively the unit can also be used as a crossover to generate a subwoofer signal for instance.

14] The *SUPER BASS* key has three functions:

a) *PROCESS*, when pressed once the intensity of the super bass function can be adjusted ranging from 0 to 100 (“PROC” will light up).

b) Pressed a second time the *TUNE* parameter can be set (“Hz” will light up). Here the *TUNE* control sets the upper cut-off frequency of the super bass function. The cut-off frequency can be adjusted within a range of 50 to 150 Hz.

c) Here, too, the third function is reached by pressing the *SUPER BASS* key for more than 2 seconds. The lower frequency band is now muted. This is indicated by a full GR LO LED bar that flashes on and off.



**When the *EXCITER* and *SUPER BASS* keys are pressed simultaneously, the crossover frequency between the lower and higher bands of the multiband compressor can be adjusted from 20 Hz to 20 kHz.**

15] The *IN/OUT* key enables you to bypass the DSP1424P. The green LED lights up as soon as the ULTRAMIZER PRO is activated.

16] Whenever a setting has been changed, the *PRESET* key starts to blink slowly, indicating that a preset has been changed but not stored. When the *PRESET* key is pressed once the current preset number is shown in the numeric display. When the *PRESET* key is pressed again the current preset number starts flashing, you can then select any of the 50 memory locations. Press a third time to save the edited program to a user preset as shown in the display.



**When the *IN/OUT* and *PRESET* keys are pressed simultaneously, the ULTRAMIZER PRO enters the MIDI menu, where all MIDI settings can be edited.**

17] Use the *POWER* switch to switch the ULTRAMIZER PRO on or off. The *POWER* switch should be set to the “OFF” position, when you connect the unit to the mains.



**Please note that the *POWER* switch does not completely disconnect the device from the mains. If the device is not in use for a long period of time, please disconnect it from the mains by unplugging the power cord from the power socket.**

# ULTRAMIZER PRO DSP1424P

## 1.3.2 Back panel

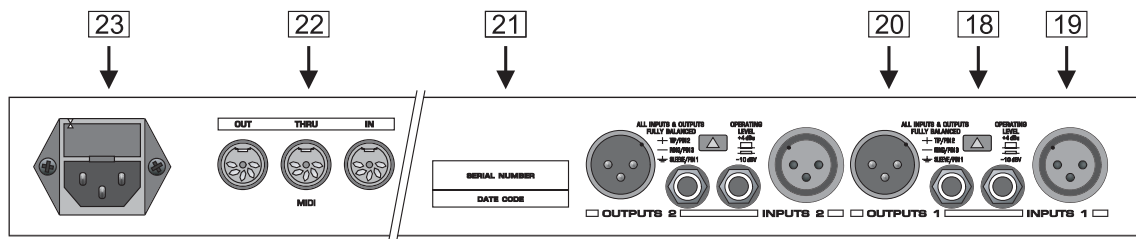



Fig. 1.4: Back panel connectors and control elements

- 18 Use the *OPERATING LEVEL* switch to adapt the ULTRAMIZER PRO to different operating levels. You can select a -10 dBV semi-pro level used for home recording and a +4 dBu level used in professional studios. This way the ULTRAMIZER PRO is always optimally adapted to the used nominal operating level.
  - 19 These are the ULTRAMIZER PRO's analog *INPUTS*. The ULTRAMIZER PRO has both XLR and 1/4" TRS inputs and outputs. Each XLR and jack set is wired parallel and can be used either balanced or unbalanced.
  - 20 These are the ULTRAMIZER PRO's analog *OUTPUTS*. Also on balanced XLR and 1/4" TRS connectors.
  - 21 *SERIAL NUMBER*. Please complete and return the warranty card within 14 days of the date of purchase. Otherwise, you will lose your right to the extended warranty. Alternatively, you can register online at our website under [www.behringer.com](http://www.behringer.com).
  - 22 These are the ULTRAMIZER PRO's MIDI connectors (*MIDI OUT / THRU / IN*). Via these connectors total remote control is possible.
  - 23 This is the *MAINS CONNECTOR / FUSE HOLDER / VOLTAGE SELECTOR*. Before you connect the unit, please make sure that the displayed voltage corresponds to your mains supply. Please note that the AC voltage selection is defined by the position of the fuse holder. If you intend to change the operating voltage, remove the fuse holder and turn it by 180 degrees before you reinsert it. Matching the two markers monitors the selected voltage. Please note that, depending on the mains voltage supplied to the unit, the correct fuse type and rate must be installed (see chapter 6 "SPECIFICATIONS"). Please use the enclosed mains cable to connect the unit to the mains power supply.
-  **Please note that not all appliances can be used with different mains voltage ratings. Please check the description on the back of the unit and the box.**

## 1.3.3 Restoring factory defaults

To protect the DSP1424P against user errors, an important edit command has been implemented via a particular key combination. In normal operating mode the presets cannot be reset to their factory defaults, so as to secure your own programs as safely as possible. Please proceed as follows to reinitialize the preset default settings:

-  **Press and keep the keys EFFECT and PRESET before powering up the ULTRAMIZER PRO. Then switch on the DSP1424P and keep the two keys pressed for about two seconds. The program numbers are counted up and reset to their original default settings.**

## 2. OPERATION

The ULTRAMIZER PRO is one of the latest generation digital processing devices. Especially designed for processing the total mix or complex music signals. BEHRINGERS past experience in digital and analog processing devices come together in this new device. In the DSP1424P, the advantages of digital technology go hand in hand with the warm and powerful sound of analog devices. The ULTRAMIZER PRO combines multiple functions for the processing of stereo signals in one device. It is a multi-band compressor, a 3D surround processor, a denoiser as well as an exciter and a bass processor.

# ULTRAMIZER PRO DSP1424P

---

Despite this unbelievable processing power the DSP1424P can be intuitively operated with an audio quality previously unimaginable.

## 2.1.1 The Ultramizer function

With the Ultramizer function you can increase the loudness and density of the program material. The DSP1424P analyzes the received music material and adapts the settings automatically. The function of the Ultramizer is dependent on the the setting of the RANGE parameter. When the RANGE parameter is set relatively high, the Ultramizer function will perform these two actions:

- ▲ The Ultramizer function adjusts the parameters of the compressors to achieve the desired (set) DENSITY in both bands.
- ▲ The total volume is raised to the MAX OUT LEVEL. The total gain is adjusted in a way that the output limiter will have a slight gain reduction. All relative parameters are continuously monitored to keep the DENSITY at whatever level you have set.

When the RANGE parameter is set at zero or a small value, the total output will not increase (or only slightly increase). Only the DENSITY will be increased, resulting in a gain reduction at the output. This setup is advisable when an increase of gain is unwanted, for instance in live applications where an unexpected increase in gain can lead to feedback.

### ULTRAMIZER DENSITY

After pressing the ULTRAMIZER key once, you have access to the parameter DENSITY. DENSITY is a combination of parameters governing the perceived density of the signal.

### ULTRAMIZER SPEED

After pressing the ULTRAMIZER key a second time, the parameter SPEED can be set. This is the relative speed with which the parameters of the compressor, limiter and gain at the input will be altered to adapt to the incoming audio. Choose a low speed when the Ultramizer function must do its job inaudible and high speed when fast recovery from transients is needed. When low speeds are chosen, the Ultramizer function will adapt slowly to new incoming signals, although the limiter will still perform as a “brick wall” limiter which will affect transients.

### ULTRAMIZER RANGE

The parameter RANGE, which you access after pressing the ULTRAMIZER key three times, determines the maximal gain the Ultramizer function will apply to the signal. This way, fade ins and fade outs remain unaffected. It is even possible to set this value to zero so that no amplification is allowed but the density will increase when a high enough level is applied to the input. When the applied signal reaches the MAX OUT LEVEL the signal will be compressed and limited by the multiband compressor and the output limiter. This will prevent distortion while maximizing the loudness, without the risk of feedback caused by an increase in gain during quiet(er) moments. This function is particularly useful when using the ULTRAMIZER PRO live, where unexpected gain increase may cause feedback.

## 2.1.2 The Max. Out Level function

Integrated in the design of the ULTRAMIZER PRO is its limiter function. Key value in almost all functions is the maximum output level that is set here. This value is a so called “brick wall” that cannot be exceeded under any circumstances when the ULTRAMIZER PRO is engaged. The level can be set from -48 to 0 dB, with reference to the internal digital level (“dB” will light up in the display). 0 dB corresponds to +16 dBu. This level is simply set by the following steps:

1. Set the MAX OUT LEVEL to a low value.
2. Apply a signal to the input of the ULTRAMIZER PRO that is loud enough to be limited constantly.
3. Slowly turn the MAX OUT LEVEL up until the clip LEDs of the connected power amplifier light up occasionally.

After setting the correct MAX OUT LEVEL the preset can be stored to match at any time the same amplifier and speakers.

You can adjust the MAX. OUT LEVEL parameter in two different ways: The peak and RMS mode. In peak mode you can adjust a maximum peak value which will not be exceeded. In RMS mode you set an average maximum level. You can switch between these two modes by pressing the MAX. OUT LEVEL key for about 2 seconds. Additionally, the “RMS” LED in the display will light up.

# ULTRAMIZER PRO DSP1424P

---

## 2.1.3 The Exciter function

The ULTRAMIZER PRO's exciter function adds transparency and depth to the audio signal. Classical music material gains transparency and musicality while popular music keeps the desired brilliance. Two parameters govern the performance of the exciter function, both can be accessed by means of the EXCITER key.

### EXCITER PROCESS

When pressed once you gain access to the exciter PROCESS parameter. The "PROC" LED next to the numeric display will light up to show this. Now you can set the intensity of the exciter effect within the range of 0 to 100.

### EXCITER TUNE

When pressed twice you have access to the TUNE parameter. This refers to the lower frequency limit of the exciter function. It can be set from 4 to 12 kHz. The "kHz" LED next to the numeric display lights up to display the unit of the edited parameter.

## 2.1.4 The Super Bass function

The super bass function is the low frequency equivalent of the exciter function. Designed to process the low frequency portion of the signal and to add transparency and depth.

### SUPER BASS PROCESS

If you press the SUPER BASS key once you can access the super bass PROCESS parameter, which determines the intensity of the super bass function. The value can be set from 0 to 100 while the "PROC" LED lights up.

 **Be careful not to overload your power amplifiers or loudspeakers when you use an extreme setting of the PROCESS parameter of the super bass function. Remember, less is more.**

### SUPER BASS TUNE

When pressed twice you have access to the super bass TUNE parameter. This is the upper frequency limit of the super bass function. This can be set from 50 to 150 Hz. The "Hz" LED next to the numeric display lights up to display the unit of the edited parameter.

## 2.1.5 The 3D Surround function

With the the 3D surround function the ULTRAMIZER PRO can be used as a 3D stereo surround processor, increasing the stereo width of the program material. Whether you want to process individual instruments or the entire mix, you can set the 3D surround function "on the fly". The effect makes the sound more spacious, wider and more detailed. Since this function does not make any sense with two mono signals, the COUPLE mode must be activated to activate the 3D surround function.

 **When you use extreme settings with the 3D surround function on audio that has been processed by a reverb, the reverb can sound unnatural and too intense. This is caused by the way stereo reverbs operate. Remember, less is more.**

## 2.1.6 The Denoiser function

The ULTRAMIZER PRO's denoiser function is universally applicable and suited for all types of instrument and complex signals. The algorithm of the denoiser function does not produce unpleasant side effects like pumping or noise tails. The parameters are for a large part chosen automatically depending on the program material and the two parameters, which can be accessed with the DENOISER key.

### DENOISER THRESHOLD

When the DENOISER key is pressed once, the THRESHOLD can be set. This function reflects the noise gate and is used to remove unwanted noise during pauses. When the denoiser THRESHOLD is being set the "dB" LED beside the numeric display lights up. The setting can range from -90 to 0 dB (no signal reaches the output). "OF" means the denoiser function is deactivated.

### DENOISER SENSITIVITY

When the DENOISER key is pressed twice you can edit the parameter SENSITIVITY. With this parameter, you determine the sensitivity of the dynamic high cut filter. This function is highly useful to remove noise from your audio. The "SENS" LED next to the numeric display indicates that the sensitivity is being edited.

 **The optimal adjustment of the SENSITIVITY parameter depends on the type of noise and program material. Take the time to set the SENSITIVITY parameter with care.**

## 2.1.7 The Crossover parameter

The advantage of multiband processing is in the division of the audio spectrum into several bands, in order to avoid the negative effects of spectral intermodulation. The choice of the crossover frequency which divides the bands has influence on how the processing takes place. With complex composite signals the crossover frequency should be in the bass area ( $\pm 500$  Hz e.g. in order to prevent modulation of the mid and high frequency range by the energy produced in the bass area). With single instruments and vocals, however, a higher crossover frequency is more desirable (2 kHz), since the center point of the power spectrum is shifted here.

For complete flexibility the crossover frequency can be set anywhere from 20 Hz to 20 kHz, in 31 steps according to the ISO frequencies. This enables the ULTRAMIZER PRO to be used not only as a mastering device but also as a processor for single instruments and vocals. If you set the crossover frequency to the maximum or minimum value (20 Hz or 20 kHz), the ULTRAMIZER PRO will operate as a broadband compressor.

Feel free to experiment with different crossover frequency settings and pretty soon a feeling for the right setting will arise, making the ULTRAMIZER PRO that much more effective and useful.

## 2.2 Selecting presets

The ULTRAMIZER PRO stores 50 user-definable presets. After power-up, the unit automatically recalls the preset last used. To select another preset, make sure that the PRESET key is pressed once. Use the jog wheel to enter the preset number of your choice. Turn the wheel clockwise to increment the preset number, or counterclockwise to decrement it.

 **Please note that the ULTRAMIZER PRO generally activates the selected presets only after about one second, which is indicated by a dot in the lower right corner of the display. After loading the data, the ULTRAMIZER PRO enables the preset and the dot disappears. This brief interruption avoids the direct activation of every preset, as you scroll through the preset list with the jog wheel. Thus, the ULTRAMIZER PRO makes sure that no “unwanted” presets are loaded unintentionally. Additionally, you can rotate the jog wheel at high speed and still have the time to specifically select the preset of your choice, instead of any of its “neighbors”.**

## 2.3 Editing presets

Editing presets is easy on the ULTRAMIZER PRO. Basically, all essential parameters can be selected directly via the keypad and edited with the jog wheel. Some keys have multiple functions that can be accessed by pressing that particular key repeatedly.

Use the LEFT and RIGHT keys to edit the left or right audio channel settings. Of course, you can edit both channels at the same time in COUPLE mode.

 **Whenever you edit one of the two audio channels and then switch to couple mode, the parameters of the active channel will be copied to the other; i.e. if you press LEFT before RIGHT, left will be copied to right. Finally, you can also save the edits made to the preset.**

## 2.4 Saving presets

Use the PRESET key to save an edited preset. Basically, all parameter changes can be saved. Whenever you're editing a preset, the display starts flashing to indicate that the edits will be saved only when you confirm them by pressing the PRESET key twice. Example:

▲ You recall a preset for editing. Then you edit the preset as desired using the function keys and the jog wheel. During this process, the flashing PRESET key reminds you that the preset settings have been changed but not saved yet. Press the PRESET key once. The display reads the current preset number. When pressed again this number starts flashing. To keep the original preset, use the jog wheel to select another preset that can be overwritten. Press the PRESET key a third time to save the edits to the selected preset. If you wish to overwrite the original preset, simply press the PRESET key three times (after editing) to save all changes you have made.



# ULTRAMIZER PRO DSP1424P

 Whenever you have edited a preset and pressed the PRESET key three times, all previous settings in this preset are erased and overwritten with the new parameter values. However, if you wish to keep the original preset, use the jog wheel to select another preset *before* you press the PRESET key a third time.

## 2.5 MIDI control

Use the MIDI key combination to select the MIDI parameters you wish to adjust. For this purpose press and keep the IN/OUT and the PRESET keys for about two seconds. All parameters can be edited with the jog wheel and the IN/OUT key. The MIDI menu includes six pages which you can select by pressing the IN/OUT key (forwards) and the PRESET key (backwards) several times.

On the first page you can select the MIDI channel. The display reads a small “c” (= channel). The jog wheel adjusts a channel from 1 through 16. To switch off the MIDI function simply select the “0” value (displayed as “-”).

On the second page you can select MIDI omni mode, i.e. the unit transmits/receives on all 16 MIDI channels. The display reads “O” (= omni). Use the jog wheel to activate (“1”) or deactivate (“0”) omni mode.

The third page allows for configuring controller commands. On its right-hand side, the display reads a capital “C” (= controller). The jog wheel selects one of the following four controller modes:

Display	Mode
0	No controller data is transmitted
1	Controller data is received but not transmitted
2	Controller data is transmitted but not received
3	Controller data is transmitted and received

*Tab. 2.2: Controller settings*

The fourth page gives you access to the program change setup. The display reads a capital “P” (= program). Here, too, four modes can be selected with the jog wheel, as follows:

Display	Mode
0	No program change data are transmitted
1	Program change data are received but not transmitted
2	Program change data are transmitted but not received
3	Program change data are transmitted and received

*Tab. 2.3: Program change settings*

The fifth page of the MIDI menu shows the “store enable” flag represented by a capital “S” in the display. The value “0” disables the reception of controller #86, and therefore protects the user presets from being modified via MIDI. Accordingly, the value “1” enables MIDI controller #86 so that you can modify or replace presets with a remote MIDI device or a sequencer. In this case the actual settings will be stored directly to the location that corresponds to the controller value.

 **Attention! Since the “store enable” mode allows you to access memory locations directly via MIDI, it is possible that stored presets will be replaced or altered if controller #86 messages are sent on the same MIDI channel. The purpose of this mode is to facilitate MIDI backup and restore operations without express confirmation at the ULTRAMIZER PRO. It is therefore recommended to disable (flag = 0) this mode as soon as the intended data transfer has ended. This is done automatically when you switch off the ULTRAMIZER PRO.**

On the sixth page you can access the “system exclusive” functions. This is indicated by a “d” (for dump) in the display. To the left of this “d” a number is displayed:

“d0” means that no SYSEX data will be sent or accepted. “d1” will enable the ULTRAMIZER PRO to receive data. When PRESET is pressed the unit will wait for data, this is shown by flashing dots (LEDs) in the display.

# ULTRAMIZER PRO DSP1424P

---

The MIDI button LED flashes signaling that SYSEX data is being received. "d2" will enable the ULTRAMIZER PRO to send a "bulk dump". Start your sequencer and press PRESET on the unit to start the transmission.

If you press the IN/OUT key again on the sixth page, the ULTRAMIZER PRO quits MIDI setup mode.

To load these settings again, select "d1", press PRESET and start your sequencer. If you press IN/OUT again, you will leave the MIDI setup. You can at all times press any other key to leave the MIDI setup directly.

 **During a bulk dump all audio functions of the ULTRAMIZER PRO will be deactivated.**

The full-featured MIDI implementation of the ULTRAMIZER PRO allows for easily integrating the ULTRAMIZER PRO into any MIDI system. For detailed information on controller tabs please refer to section 5 "APPENDIX".

## ▲ MIDI IN

Any MIDI data sent to the ULTRAMIZER PRO (sequencer, MIDI footswitch, etc.) are received via the MIDI IN jack. For example, if you wish to use the ULTRAMIZER PRO as an effects device for your guitar rack, you can connect the MIDI IN jack to a MIDI footswitch (our BEHRINGER MIDI FOOT CONTROLLER FCB1010) that allows for selecting program presets. If your rack includes another MIDI effects device (e.g. a multi-effects processor), the data sent from the MIDI footswitch can be routed via the ULTRAMIZER PRO's MIDI THRU jack to your multi-effects processor.

## ▲ MIDI THRU

The MIDI THRU jack is used to loop through incoming MIDI data, i.e. any control data received at the MIDI IN of the ULTRAMIZER PRO will be transmitted via the MIDI THRU jack to other MIDI devices/instruments.

## ▲ MIDI OUT

The MIDI OUT jack allows for transmitting MIDI data that originate from the ULTRAMIZER PRO. We are currently developing a software editor which will allow for storing single items of the unit's internal data on an external medium. Thus, it will be possible to archive ULTRAMIZER PRO settings and presets on a computer, sequencer or MIDI data recorder. Both MIDI control change and MIDI program change commands will be transmitted when you edit or recall filter settings. Detailed information on this future software editor are available from our BEHRINGER hotline (phone: +49 (0) 2154-920666) and/or our internet homepage ([www.behringer.com](http://www.behringer.com)).

## 3. APPLICATIONS

The BEHRINGER ULTRAMIZER PRO features a high level of flexibility. The following chapter describes some standard applications of your ULTRAMIZER PRO.

### 3.1 Level setting

Take care to set levels properly on the ULTRAMIZER PRO! Low levels deteriorate the dynamics of the music signal, which results in a poor, weak and noisy sound. On the other hand, very high levels overdriving the converters in the ULTRAMIZER PRO should also be avoided. Digital distortion is (unlike its analog counterpart) very unpleasant as it does not occur gradually but abruptly.

Use the input level meter of the ULTRAMIZER PRO to adjust the input signal to about -10 dB. Make sure that the CLIP LED never lights up!

### 3.2 Using the ULTRAMIZER PRO in a studio environment

With its highly flexible configuration the ULTRAMIZER PRO also delivers good results in a professional studio or home recording environment. When used as a mastering device while recording or copying, the ULTRAMIZER PRO should be placed between source and recorder as shown in fig 3.1. You can realize any application ranging from slight processing to the total manipulation of music signals. For example, you can use the ULTRAMIZER PRO as a loudness maximizer, limiter and the denoiser system at the same time when copying analog tapes.



# ULTRAMIZER PRO DSP1424P

## 3.2.1 The ULTRAMIZER PRO in analog recording

In the recording and duplication field the goal should always be to achieve an optimum recording level onto the recording media. Too low or too high recording levels lead to side effects such as noise, distortion etc. In mastering and multitrack recording, as well as in duplication, one should always take care to utilize the full dynamic range of the tape recorder, DAT recorder etc. Principally, it is possible to control the recording level by “riding” faders, which means with low level signals, the gain is increased, whereas the amplitude of high level signal is reduced. It is obvious that this method is insufficient because, especially in live recordings, the expected signal levels cannot be anticipated correctly. Especially with multitrack recordings, which are run under hectic circumstances, the signal level of all channels cannot be monitored and controlled at the same time. Generally, with manual control, it is not possible to achieve satisfying recording results.

An automatic gain control system achieves better and more constant results. Use the ULTRAMIZER PRO by starting with the initial settings, and use its dynamic control functions in order to be able to drive an analog, as well as a digital recording, up to the limit of its maximum dynamic range while remaining noise- and distortion-free.

## 3.2.2 The ULTRAMIZER PRO in digital recording and sampling

In an analog recording, too low recording levels lead to an increased noise level, whereas too high levels will cause a compressed and “squashed” sound. In extreme cases, it will cause distortion due to tape saturation. In contrast to analog, side effects in the digital field always become extremely audible: with decreasing level, a tape previously recorded with insufficient level loses resolution: the recording sounds “hard” and loses “atmosphere”. With excessive level, the recording sounds harsh and heavily distorted. In order to avoid these effects, the peak limiter section of the ULTRAMIZER PRO should be placed before, for example, a sampler. The peak limiter is set with the MAX OUT LEVEL value. As a result of this process, a digital recording or a sampling event can be optimally set in level without any problem.

## 3.2.3 The ULTRAMIZER PRO in mastering

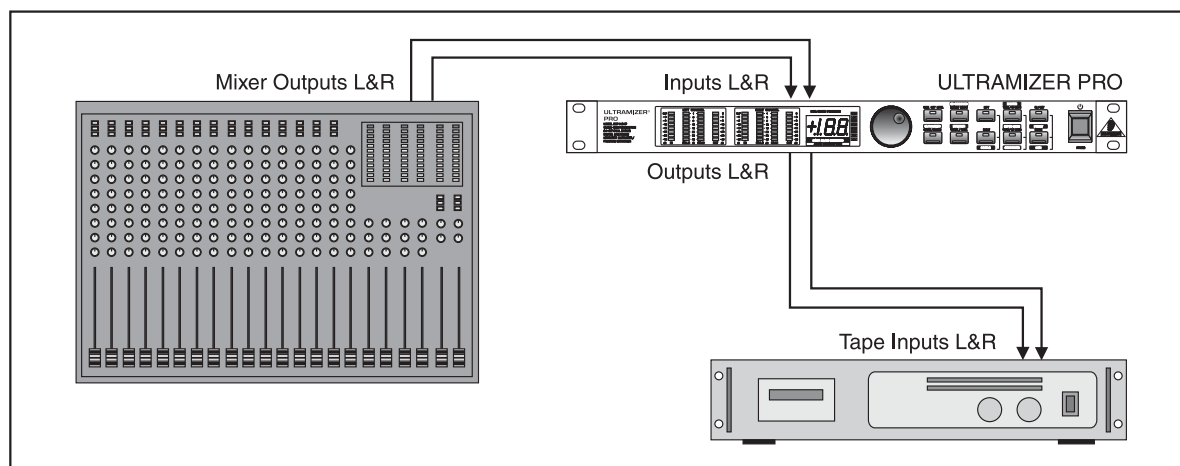

Fig. 3.1: The ULTRAMIZER PRO as mastering device

The mastering process is one of the most critical processing steps in recording. In this production step, it is the goal to achieve a “maximum level” copy of the recording, without any noise or distortion. In many applications it is further required to produce a high average volume. Quite often in these cases, dynamics suffer drastically, because the program material has been compressed and limited too heavily. Using the compressor and the peak limiter section of the ULTRAMIZER PRO allows you to drastically increase the overall volume, without audibly affecting the dynamics.

Proceed as follows:

1. Limit the dynamics of the program material by 6 dB using the peak limiter section. By softly clipping just the transients, the real audio signal will not be limited, resulting in higher headroom. The overall gain can now be increased by 6 dB, which leads to a higher volume. More than 6 dB should not be limited, otherwise side effects could become audible.

# ULTRAMIZER PRO DSP1424P

- Therefore, in addition, you should also use the ULTRAMIZER function. It is recommended that the compression is limited to the “first” 6 dB of the dynamic range only. You can monitor the gain reduction with the help of the GR LO and GR HI gain reduction meters.

The “cut” signal peaks cause a reduced recording level of about 6 dB, which is visible on the level indicators of the DAT recorder. Now increase the recording level of the recorder back to normal. The result is a louder recording without any loss of sound.

## 3.3 The ULTRAMIZER PRO as a protective device

Sound system distortion is usually a result of amplifiers and loudspeakers being driven beyond their limitations, whereby signals are hard limited by so-called “clipping” of the amplifiers. The signal peaks are thereby “clipped” because the maximum output voltage is reached, which leads to unpleasant and dangerous distortions.

Apart from the danger of long term overload a loudspeaker can also be damaged by an occasional high level overload, e.g. the sound of a microphone falling onto a hard floor. In order to protect a system or the loudspeakers, the application of the BEHRINGER ULTRAMIZER PRO is recommended. Conventional limiters must restrict the maximum output level far below the clip-point of the amplifier, in order to limit the height and duration of overloading transients. This has the disadvantage that the power reserve of the system cannot be fully exploited.

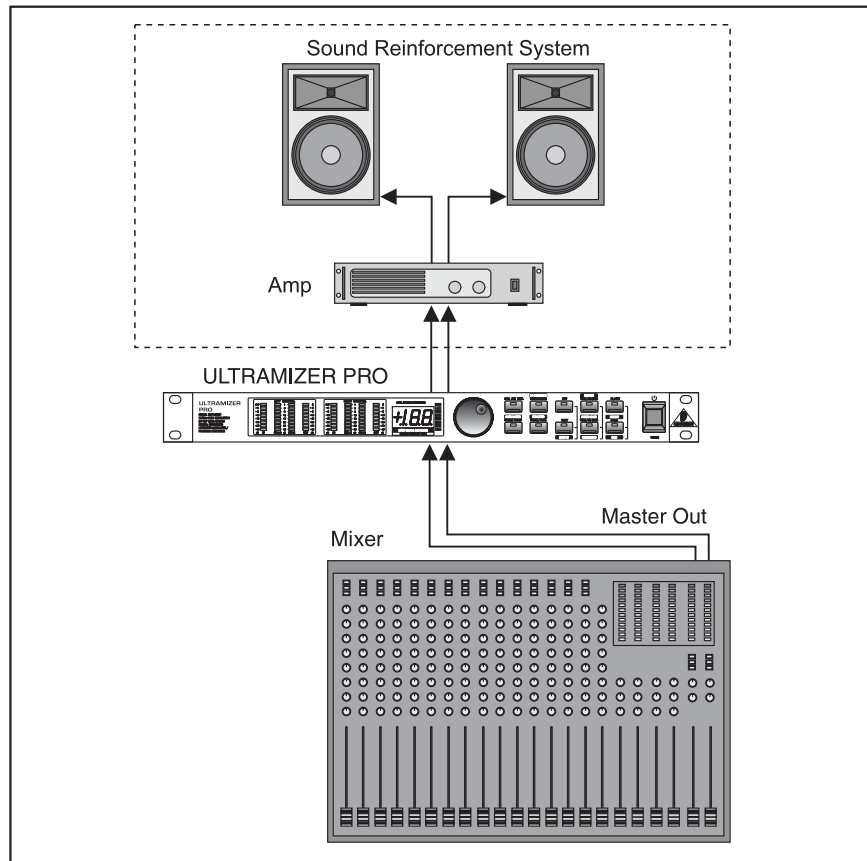

Fig. 3.2: Using the ULTRAMIZER PRO in the main mix bus

### 3.3.1 Protection of a system with a passive crossover

If your sound system incorporates a passive crossover network (included in the loudspeaker housing), insert the BEHRINGER ULTRAMIZER PRO between your mixing console output and the power amplifier input. It is used as the last link in the chain preceding the power amp. Thus, you can effectively avoid damage to the midrange/tweeter range caused by clipping of the high-energy bass signals. This statement, as paradoxical as it may seem at first, can be explained with the fact that especially low-frequency signals with high amplitudes

# ULTRAMIZER PRO DSP1424P

---

can overload the power supply in the amplifier(s). The resulting clipping (cutting off of signal peaks) produces distortion (upper harmonics), which is abruptly added to the midrange/tweeter signals. For this reason, “weak” power amps, in particular, must be protected by a limiter in their input dynamics.

## 3.3.2 Protection of a system with an active crossover

When used with a system that features an electronic crossover, connect the ULTRAMIZER PRO before the crossover. In this application, the BEHRINGER ULTRAMIZER PRO will process the entire audio frequency spectrum.

 **If you want to protect one or more separate units in a multi-way active system you can use a (multi)way compressor/limiter between the electronic crossover and the amplifier(s) like the BEHRINGER MULTICOM PRO-XL MDX4600.**

## 3.3.3 Improving the sound of a processor system

An electronic crossover divides the total frequency spectrum in separate bands, corrects the single units' frequency responses and time alignment. A processor system is a PA system which contains a special active crossover with additionally dynamic functions that monitor the system performance and optimize the output dependent on the program material. Each band has its own limiter whose task it is to limit dangerous signal peaks to a certain level. This process avoids overloading the subsequent power amplifier or destruction of the loudspeaker.

In some units a “loudness contour” is applied where, for instance, the bass is boosted at low levels to extend the range of the system at the low end. At higher levels, this frequency correction is abandoned in exchange for a higher maximum sound pressure level. In many cases, this function leads rather to a disturbance than to an improvement of the sound quality.

If the ULTRAMIZER PRO is placed before the processor, the signal peaks can be eliminated before they reach the limiters of the processing system. The sound quality therefore remains natural and free of side effects caused by the dynamic functions of the crossover.

## 3.4 The ULTRAMIZER PRO in combination with a multitrack

In connection with multi-track machines the BEHRINGER ULTRAMIZER PRO can be used to prevent distortion caused by saturation and to minimize tape hiss. Adjustment is fairly straight forward, maximum level is easily determined and fixed for the same kind of tape. Limiting the audio level enables a higher nominal level of the recording, with a dramatically improved signal-to-noise ratio.

## 3.5 The ULTRAMIZER PRO in broadcast

The main aim of processing sound recordings for commercial radio and television is to achieve a maximum transmission volume.

### What is volume?

Volume is defined as the relationship between the average level of program material to peak-to-peak level, in response to amplitude and duration. The higher the average level and the time it remains at a high level, the louder the program material will be perceived by the listener.

If you want to run your broadcast station at maximum average volume, proceed as mentioned in chapter 3.2.2. Please make sure that the maximum peak level is below the threshold of the transmitter's limiter, otherwise this could lead to very hard and audible use of the transmission limiters. Keep in mind that a heavy increase in average volume by means of compression always leads to a loss in dynamics and an increased perception of side effects. The moderate use of the ULTRAMIZER PRO results in higher average volumes, free of distortion.

Due to the multiband processing, the ULTRAMIZER PRO is capable of processing entire audio signals inaudibly to protect subsequent devices. With same or higher, subjective volume signal processing by the ULTRAMIZER PRO is felt as a clear sound improvement, without the transmitter's limiter responding. Digital devices are well suited to handle the large dynamic range of classical music. For broadcasting however this is not desired. Ambient noise, people talking in a restaurant, wind noise in a car etc., can drown out quiet pieces of the music very easily. The ULTRAMIZER PRO raises these pieces in volume without falsifying dynamics and transients audibly.

# ULTRAMIZER PRO DSP1424P

With television broadcasts varying volume levels can cause problems: Announcements, jingles, dialog and background music can differ strongly in level. Here, too, the ULTRAMIZER PRO can level out these differences in the program material and can thus provide a constant volume. Moderate use of the compressor, peak limiter, super bass and exciter sections of the ULTRAMIZER PRO will help to achieve high and distortion-free nominal volumes without loss of liveliness.

## 3.5.1 AM/TV broadcasting

AM broadcast has a clearly limited transmission bandwidth and relatively limited dynamics. The goal is to limit the signal dynamics in such a way that the transmitted power is as constant as possible. The ULTRAMIZER PRO permits the optimal use of the individual frequency bands continuously to optimize, in order to use the bandwidth limited anyway and the signal-to-noise ratio permanently, close at the maximum. FM broadcast is more sensitive to signal processing due to the larger bandwidth and dynamics. Most commercial transmitters want to transmit with the highest obtainable average level and use a multiplicity of signal processors to achieve this—despite the effects on the quality of the program material.

If a limiter with active pre-emphasis is used, the ULTRAMIZER PRO should be placed directly before it. That way the transmitter's subsequent limiter limits the signal less resulting in an improved overall sound. As TV sound is usually also transferred in FM, the same goes for processing TV sound.

## 3.5.2 Telephone lines and wireless systems

The ULTRAMIZER PRO can dramatically improve the signal to noise ratio of telephone lines and wireless systems while at the same time guarding subsequent devices against overload. They produce an even modulation level and constantly keep the signal peaks under control. The studio can maximize the level without the risk of overloading.

## 3.6 Using the ULTRAMIZER PRO on inserts

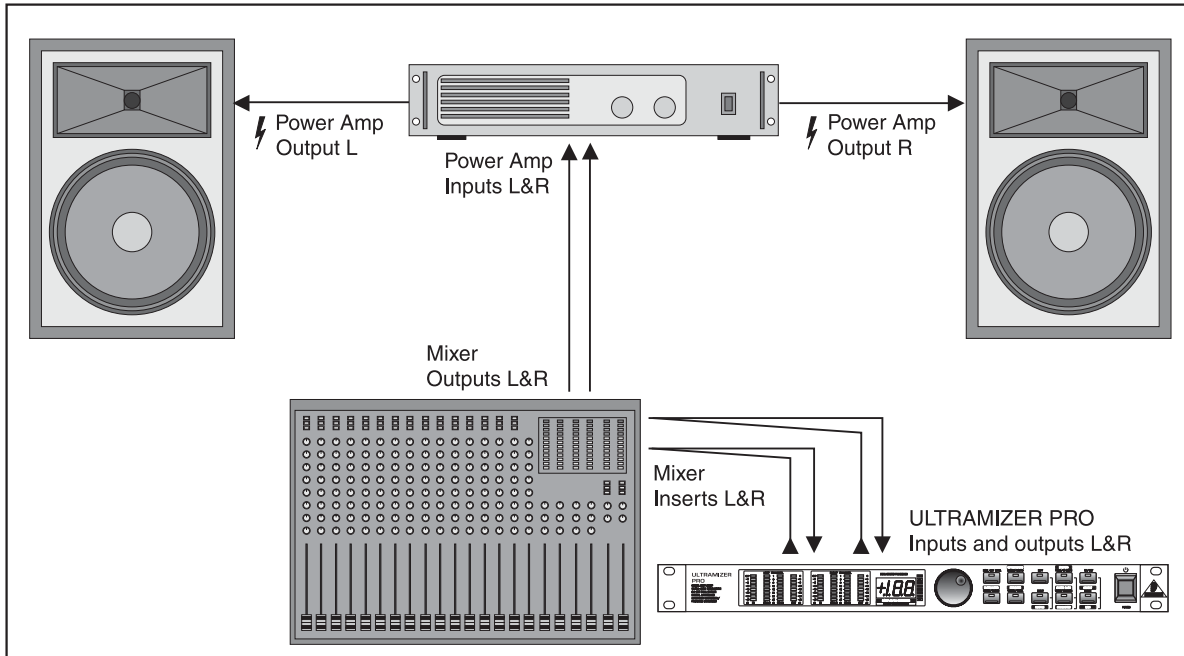

Fig. 3.3: Inserting the ULTRAMIZER PRO in single channels and subgroups

You can also insert the ULTRAMIZER PRO in single channels, subgroups as well as the main mix channels. Use the first two options when you want to process individual signals or a group of signals. This way you can process only the microphones or the DJ.

# ULTRAMIZER PRO DSP1424P

## 3.7 The ULTRAMIZER PRO in a MIDI setup

Owing to the integrated MIDI interface you can fully control the DSP1424P in a MIDI setup. The ULTRAMIZER PRO can both receive and transmit program changes and controller changes. Wire the unit as follows.

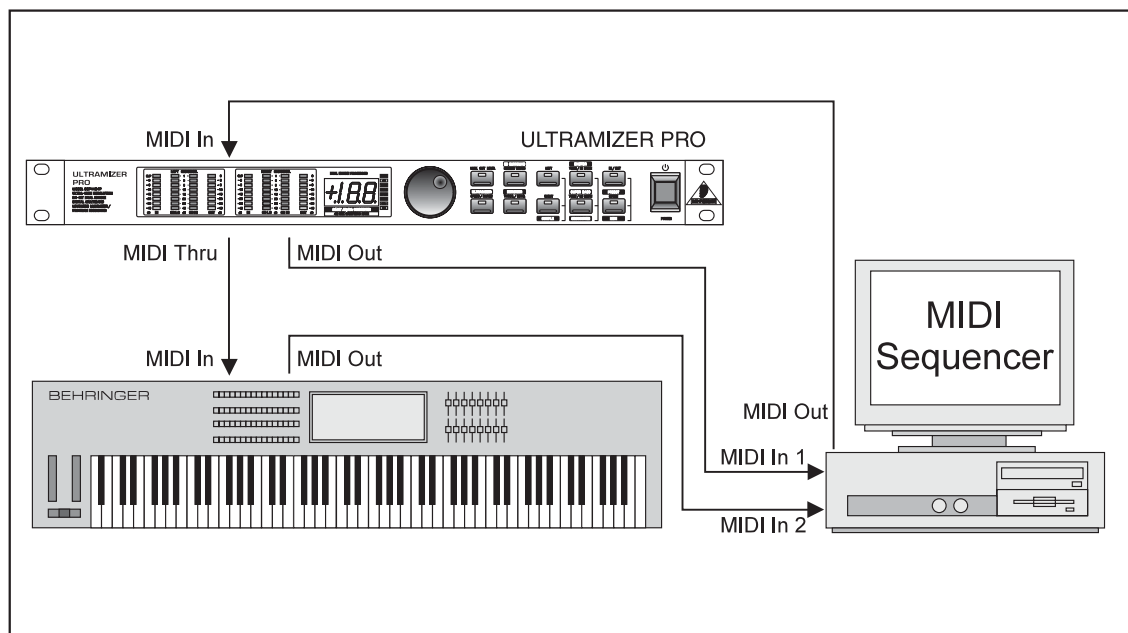

Fig. 3.4: The ULTRAMIZER PRO in a MIDI setup

## 3.8 Saving data via MIDI

The ULTRAMIZER PRO's MIDI implementation also allows for archiving one or several presets on an external storage medium. Proceed as follows:

Connect the MIDI OUT jack of the ULTRAMIZER PRO to the MIDI IN jack of a MIDI data recorder (e.g. sequencer). Press the PRESET and IN/OUT keys simultaneously to enter MIDI mode. Set program change mode to 0 and controller change mode to 3. Now quit MIDI mode by pressing the PRESET key. Use the jog wheel to select the preset whose data you wish to save. When the preset is activated, its parameters are transmitted as controller data and can be recorded on a sequencer or similar device. Repeat this routine until all presets of your choice have been sent to the external data recorder.

To load archived data back into the ULTRAMIZER PRO, you must enable controller reception in MIDI mode (see 2.5). Then, start the sequencer to automatically transmit each preset data set back to the ULTRAMIZER PRO. Press the PRESET key, select a program location to store the data and then again press the PRESET key. If you want to automate MIDI store functions, you must enable the store mode to switch on the reception of controller #28. This allows you to directly store any modification of the actual preset on the preset number that is transmitted with the controller. You can also restore a complete preset that has previously been recorded with a MIDI sequencer on the same location it had before.

## 4. INSTALLATION

Your BEHRINGER ULTRAMIZER PRO was carefully packed in the factory and the packaging was designed to protect the unit from rough handling. Nevertheless, we recommend that you carefully examine the packaging and its contents for any signs of physical damage, which may have occurred in transit.

 **If the unit is damaged, please do not return it to us, but notify your dealer and the shipping company immediately, otherwise claims for damage or replacement may not be granted. Shipping claims must be made by the consignee.**

### 4.1 Rack mounting

The BEHRINGER ULTRAMIZER PRO fits into one standard 19" rack unit of space (1 3/4"). Please allow at least an additional 4" depth for the connectors on the back panel. Be sure that there is enough air space around the unit for cooling and please do not place the ULTRAMIZER PRO on high temperature devices such as power amplifiers etc. to avoid overheating.

### 4.2 Mains connection

The mains connection of the ULTRAMIZER PRO is made by using a mains cable and a standard IEC receptacle. It meets all of the international safety certification requirements.

 **Please make sure that all units have a proper ground connection. For your own safety, it is advisable not to remove the ground connection within the units or at the supply, or fail to make this connection at all.**

Before you switch on the unit, check that it is configured to match your AC mains voltage requirements. If it does not comply, then it is necessary to switch the operating voltage to the correct supply requirements BEFORE turning on the unit, otherwise the unit could be severely damaged. You will find this combined fuse holder/voltage selector at the back, adjacent to the IEC receptacle. **IMPORTANT: This does not apply for general export models which are built for one operating voltage only.**

The AC voltage selection is defined by the position of the fuse holder. If you intend to change the operating voltage, remove the fuse holder and twist it by 180 degrees before you reinsert it. Matching the two markers monitors the selected voltage.

 **If the unit is switched to an other operating voltage, the fuse rating must be changed. See the technical specifications for further information.**

A safety fuse protects the unit from serious defects. If the fuse blows, this is a warning sign and always indicates that the circuit is overloaded. The fault must always be repaired before the fuse is replaced. If the safety fuse is faulty and needs replacing after the unit is repaired, please make sure that you replace it only with the identical type and rating. NEVER use fuses of different ratings or cover faulty fuses with aluminum foil. This can cause fire and electric shocks and will endanger your life and the lives of others.

### 4.3 Audio connections

As standard, the BEHRINGER ULTRAMIZER PRO is installed with electronically servo-balanced inputs and outputs. The new circuit design features automatic hum and noise reduction for balanced signals and thus allows for trouble-free operation, even at high operating levels. Externally induced mains hum etc. will be effectively suppressed. The automatic servo-function recognizes the presence of unbalanced connectors and adjusts the nominal level internally to avoid level differences between the input and output signals (correction 6 dB).

 **Please ensure that only qualified persons install and operate the ULTRAMIZER PRO. During installation and operation the user must have sufficient electrical contact to earth. Electrostatic charges might affect the operation of the ULTRAMIZER PRO!**

# ULTRAMIZER PRO DSP1424P

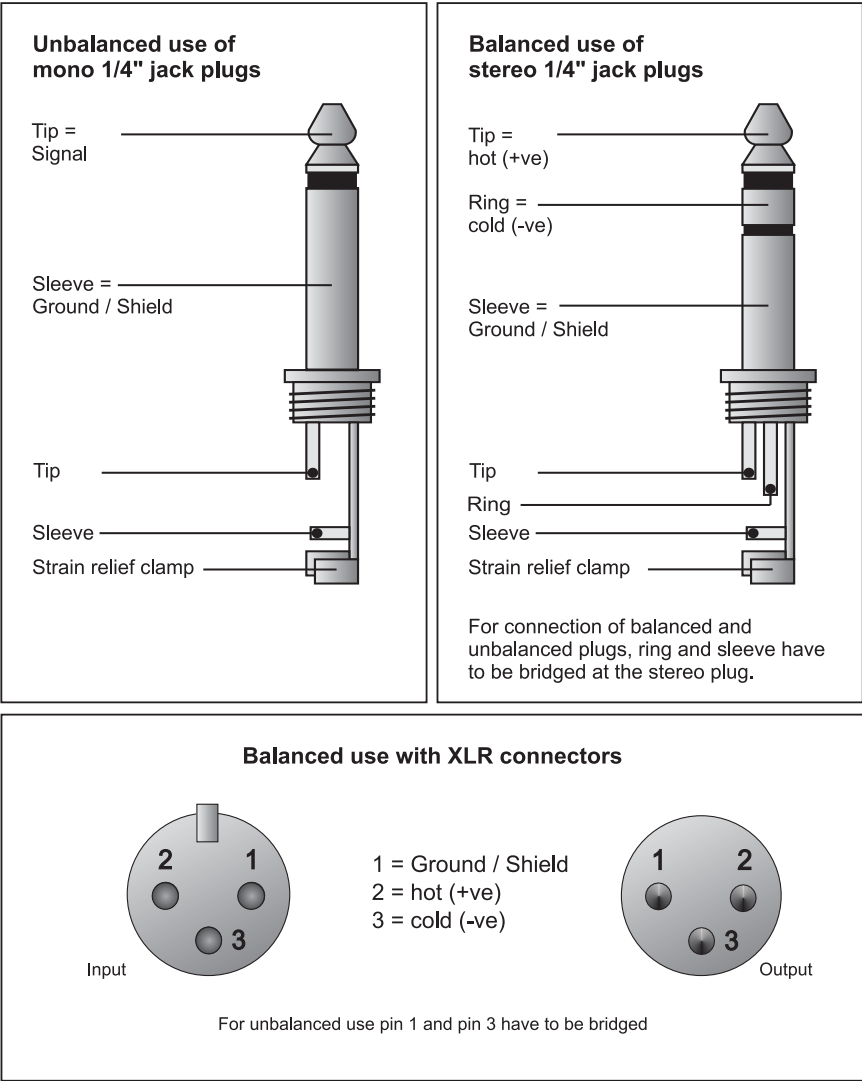

Fig. 4.1: Different plug types



## 5. APPENDIX

### 5.1 MIDI implementation

<b>MIDI Implementation chart</b>				
Function		Transmitted	Recognized	Remarks
Basic	Default	OFF, 1 - 16	OFF, 1 - 16	memorized
Channel	Changed	OFF, 1 - 16	OFF, 1 - 16	
Mode	Default	1,2,3,4	1,2,3,4	
	Messages	X	X	
	Altered	X	X	
Note Number		X	X	
	True Voice	X	X	
Velocity	Note ON	X	X	
	Note OFF	X	X	
After Touch	Key's	X	X	
	Ch's	X	X	
Pitch Bender		X	X	
Control		O 70 - 87	O 70 - 87	see add. Table
Progr.		O (0-49)	O (0-49)	
Change	True #	1-50	1-50	
System Exclusive		X	X	
System Common	Song Pos	X	X	
	Song Sel	X	X	
	Tune	X	X	
System Real Time	Clock	X	X	
	Commands	X	X	
Aux Messages	Local ON/OFF	X	X	
	All notes OFF	X	X	
	Active Sense	X	X	
	Reset	X	X	
Notes				

O = YES, X = NO

Mode 1: OMNI ON, POLY

Mode 2: OMNI ON, MONO

Mode 3: OMNI OFF, POLY

Mode 4: OMNI OFF, MONO

Tab. 5.1: MIDI implementation chart

Parameter Name	Display Range	Midi Controller Number	Controller Value Range
Max. Out Level	-48 .. 0	70	0 .. 48
RMS Mode		71	0 = Peak, 1 = RMS
Stereo Width	0 .. 100	72	0 .. 100
Ultramizer Density	0 .. 100	73	0 .. 100
Ultramizer Speed	1 .. 100	74	0 .. 99
Ultramizer Range	0 .. 24	75	0 .. 24
Denoiser Threshold	OF, -90 .. 0	76	0 .. 91
Denoiser Sensitivity	0..100	77	0 .. 100
Left / Right	-	78	0 = coupled, 1 = L, 2 = R
Exciter Process	0 .. 100	79	0 .. 100
Exciter Tune	4 .. 12	80	0 .. 100
Super Bass Process	0 .. 100	81	0 .. 100
Super Bass Tune	50 .. 150	82	0 .. 100
Crossover	20 (Hz) .. 20 (kHz)	83	0 .. 30
Low Mute	-	84	0 = On, 1 = Mute
High Mute	-	85	0 = On, 1 = Mute
Store	-	86	0 .. 49
In / Out	-	87	0 = Out, 1 = In

Tab. 5.2: Controller functions with MIDI

# ULTRAMIZER PRO DSP1424P

---

## 6. SPECIFICATIONS

### Analog inputs

Connectors	XLR and 1/4" TRS
Type	RF filtered, servo balanced input
Impedance	60 k $\Omega$ balanced, 30 k $\Omega$ unbalanced
Nominal operating level	-10 dBV to +4 dBu (switchable)
Max. input level	+16 dBu at +4 dBu nominal level, +2 dBV at -10 dBV nominal level

### Analog outputs

Connectors	XLR and 1/4" TRS
Type	Electronically servo-balanced output stage
Impedance	60 $\Omega$ balanced, 30 $\Omega$ unbalanced
Max. output level	+16 dBu at +4 dBu nominal level, +2 dBV at -10 dBV nominal level

### System specifications

Frequency response	20 Hz to 20 kHz, +/- 3 dB
Noise	> 94 dB, unweighted, 20 Hz to 20 kHz
THD	0.0075 % typ. @ +4 dBu, 1 kHz, Gain 1
Crosstalk	< -76 dB

### MIDI interface

Type	5-pin DIN socket IN / OUT / THRU
------	----------------------------------

### Digital processing

Converters	24-bit Sigma-Delta, 64/128-times oversampling
Sampling rate	46.875 kHz

### Display

Type	2 1/2-digit numeric LED display
------	---------------------------------

### Power supply

Mains Voltages	USA/Canada	120 V ~, 60 Hz
	U.K./Australia	240 V ~, 50 Hz
	Europe	230 V ~, 50 Hz
	General Export Model	100 - 120 V ~, 200 - 240 V ~, 50 - 60 Hz
Fuse	100 - 120 V ~:	<b>T 250 mA H</b>
	200 - 240 V ~:	<b>T 125 mA H</b>
Power consumption	10 Watts	
Mains connection	Standard IEC receptacle	

### Physical

Dimensions (H x W x D)	1 3/4" (44.5 mm) x 19" (482.6 mm) x 7 1/2" (190.5 mm)
Net weight	approx. 2 kg
Shipping weight	approx. 3 kg

BEHRINGER is constantly striving to maintain the highest professional standards. As a result of these efforts, modifications may be made from time to time to existing products without prior notice. Specifications and appearance may differ from those listed or shown.

## 7. WARRANTY

### § 1 WARRANTY CARD/ONLINE REGISTRATION

To be protected by the extended warranty, the buyer must complete and return the enclosed warranty card within 14 days of the date of purchase to BEHRINGER Spezielle Studiotechnik GmbH, in accordance with the conditions stipulated in § 3. Failure to return the card in due time (date as per postmark) will void any extended warranty claims. Based on the conditions herein, the buyer may also choose to use the online registration option via the Internet ([www.behringer.com](http://www.behringer.com) or [www.behringer.de](http://www.behringer.de)).

### § 2 WARRANTY

1. BEHRINGER (BEHRINGER Spezielle Studiotechnik GmbH including all BEHRINGER subsidiaries listed on the enclosed page, except BEHRINGER Japan) warrants the mechanical and electronic components of this product to be free of defects in material and workmanship for a period of one (1) year\* from the original date of purchase, in accordance with the warranty regulations described below. If the product shows any defects within the specified warranty period that are not excluded from this warranty as described under § 3 and 4, BEHRINGER shall, at its discretion, either replace or repair the product using suitable new or reconditioned parts. In the case that other parts are used which constitute an improvement, BEHRINGER may, at its discretion, charge the customer for the additional cost of these parts.

2. If the warranty claim proves to be justified, the product will be returned to the user freight prepaid.

3. Warranty claims other than those indicated above are expressly excluded.

### § 3 RETURN AUTHORIZATION NUMBER

1. To obtain warranty service, the buyer (or his authorized dealer) must call BEHRINGER (see enclosed list) during normal business hours **BEFORE** returning the product. All inquiries must be accompanied by a description of the problem. BEHRINGER will then issue a return authorization number.

2. Subsequently, the product must be returned in its original shipping carton, together with the return authorization number to the address indicated by BEHRINGER.

3. Shipments without freight prepaid will not be accepted.

### § 4 WARRANTY REGULATIONS

1. Warranty services will be furnished only if the product is accompanied by a copy of the original retail dealer's invoice. Any product deemed eligible for repair or replacement by BEHRINGER under the terms of this warranty will be repaired or replaced within 30 days of receipt of the product at BEHRINGER.

2. If the product needs to be modified or adapted in order to comply with applicable technical or safety standards on a national or local level, in any country which is not the country for which the product was originally developed and manufactured, this modification/adaptation shall not be considered a defect in materials or workmanship. The warranty does not cover any such modification/adaptation, irrespective of whether it was carried out properly or not. Under the terms of this warranty, BEHRINGER shall not be held responsible for any cost resulting from such a modification/adaptation.

3. Free inspections and maintenance/repair work are expressly excluded from this warranty, in particular, if caused by improper handling of the product by the user.

This also applies to defects caused by normal wear and tear, in particular, of faders, potentiometers, keys/buttons and similar parts.

4. Damages/defects caused by the following conditions are not covered by this warranty:

▲ improper handling, neglect or failure to operate the unit in compliance with the instructions given in BEHRINGER user or service manuals.

▲ connection or operation of the unit in any way that does not comply with the technical or safety regulations applicable in the country where the product is used.

▲ damages/defects caused by force majeure or any other condition that is beyond the control of BEHRINGER.

5. Any repair or opening of the unit carried out by unauthorized personnel (user included) will void the warranty.

6. If an inspection of the product by BEHRINGER shows that the defect in question is not covered by the warranty, the inspection costs are payable by the customer.

7. Products which do not meet the terms of this warranty will be repaired exclusively at the buyer's expense. BEHRINGER will inform the buyer of any such circumstance. If the buyer fails to submit a written repair order within 6 weeks after notification, BEHRINGER will return the unit C.O.D. with a separate invoice for freight and packing. Such costs will also be invoiced separately when the buyer has sent in a written repair order.

### § 5 WARRANTY TRANSFERABILITY

This warranty is extended exclusively to the original buyer (customer of retail dealer) and is not transferable to anyone who may subsequently purchase this product. No other person (retail dealer, etc.) shall be entitled to give any warranty promise on behalf of BEHRINGER.

### § 6 CLAIM FOR DAMAGES

Failure of BEHRINGER to provide proper warranty service shall not entitle the buyer to claim (consequential) damages. In no event shall the liability of BEHRINGER exceed the invoiced value of the product.

### § 7 OTHER WARRANTY RIGHTS AND NATIONAL LAW

1. This warranty does not exclude or limit the buyer's statutory rights provided by national law, in particular, any such rights against the seller that arise from a legally effective purchase contract.

2. The warranty regulations mentioned herein are applicable unless they constitute an infringement of national warranty law.

\* Customers in the European Union please contact BEHRINGER Germany Support for further details.

The information contained in this manual is subject to change without notice. No part of this manual may be reproduced or transmitted in any form or by any means, electronic or mechanical, including photocopying and recording of any kind, for any purpose, without the express written permission of BEHRINGER Spezielle Studiotechnik GmbH. BEHRINGER, MULTICOM and ULTRAMIZER are registered trademarks. ALL RIGHTS RESERVED.

© 2002 BEHRINGER Spezielle Studiotechnik GmbH.

BEHRINGER Spezielle Studiotechnik GmbH, Hanns-Martin-Schleyer-Str. 36-38, 47877 Willich-Münchheide II, Germany

Tel. +49 (0) 21 54 / 92 06-0, Fax +49 (0) 21 54 / 92 06-30

# FEDERAL COMMUNICATIONS COMMISSION COMPLIANCE INFORMATION



Responsible party name: **MUSIC Group Services USA, Inc.**  
Address: **18912 North Creek Parkway,  
Suite 200 Bothell, WA 98011,  
USA**  
Phone/Fax No.: **Phone: +1 425 672 0816  
Fax: +1 425 673 7647**

## **ULTRAMIZER PRO DSP1424P**

complies with the FCC rules as mentioned in the following paragraph:

This equipment has been tested and found to comply with the limits for a Class B digital device, pursuant to part 15 of the FCC Rules. These limits are designed to provide reasonable protection against harmful interference in a residential installation. This equipment generates, uses and can radiate radio frequency energy and, if not installed and used in accordance with the instructions, may cause harmful interference to radio communications. However, there is no guarantee that interference will not occur in a particular installation. If this equipment does cause harmful interference to radio or television reception, which can be determined by turning the equipment off and on, the user is encouraged to try to correct the interference by one or more of the following measures:

- Reorient or relocate the receiving antenna.
- Increase the separation between the equipment and receiver.
- Connect the equipment into an outlet on a circuit different from that to which the receiver is connected.
- Consult the dealer or an experienced radio/TV technician for help.

This device complies with Part 15 of the FCC rules. Operation is subject to the following two conditions:

- (1) this device may not cause harmful interference, and
- (2) this device must accept any interference received, including interference that may cause undesired operation.

### **Important information:**

Changes or modifications to the equipment not expressly approved by MUSIC Group can void the user's authority to use the equipment.