

ARP Models 2600-2606 **SERVICE MANUAL**

Kybd. Model 3620 technical information is covered separately in the 3620 Kybd. Service Manual, Document Number 90004.

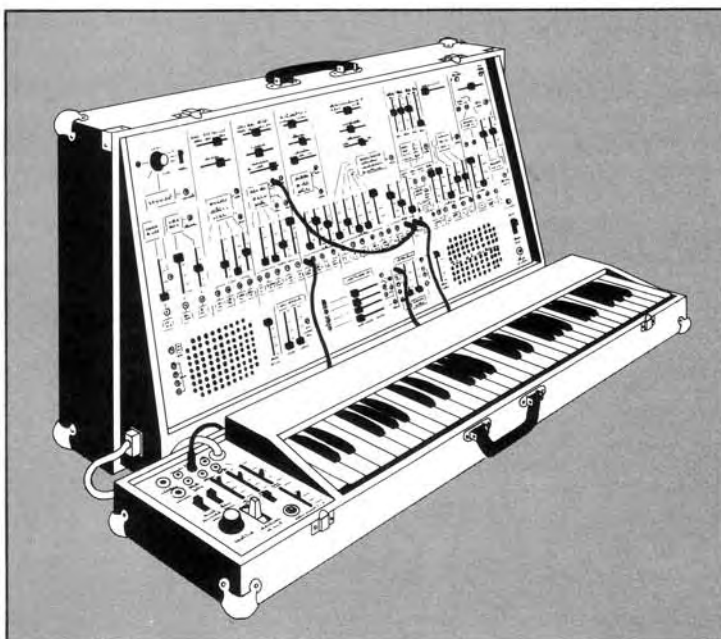

CONTENTS

SECTION 1 - General	1
SECTION 2 - Circuit Descriptions	1
SECTION 3 - Calibrations	7
SECTION 4 - Assembly & Disassembly	11
SECTION 5 - Revisions/Changes	12
SECTION 6 - Miscellaneous Notes	13
SECTION 7 - Diagrams, Schematics & Assemblies	16
SECTION 8 - Parts List	32

THE INFORMATION CONTAINED HEREIN IS CONFIDENTIAL AND PROPRIETARY TO ARP INSTRUMENTS, INC. IT IS DISCLOSED TO YOU SOLELY FOR PURPOSES OF INSTRUCTION AS TO OPERATION OF THE EQUIPMENT AND MAINTENANCE AS APPROPRIATE. IT IS NOT TO BE USED BY YOU FOR ANY OTHER PURPOSE, NOR IS IT TO BE DISCLOSED TO OTHERS WITHOUT THE EXPRESS PERMISSION OF ARP INSTRUMENTS, INC.

ARP INSTRUMENTS, INC.
45 Hartwell Avenue
Lexington, MA 02173
(617) 861-6000

Document Number 90021
(New Edition, September 1977)
© 1977 ARP Instruments, Inc.

tuning procedure for the new module and use the 4017/4027 tuning procedure for the remaining

oscillators (use the new oscillator as the tuning standard once it has been tuned.)

3.2.5 VOLTS PER OCTAVE ADJUSTMENT PROCEDURE

Ref. No.	Trimmer	Specifications/Trim Procedure
R60	VCO 1 V/OCT	<ol style="list-style-type: none"> 1. Monitor VCO 1 output (sawtooth or square) with frequency counter or other tuning standard. 2. Depress low C and adjust frequency for 100Hz. using coarse and fine tune sliders. 3. Depress high C and adjust R60 trimmer (VCO 1V/OCT) for 1600Hz. 4. Repeat steps 1 and 2 until low and high C are correct.
R78	VCO 2 V/OCT	<ol style="list-style-type: none"> 1. Repeat same procedure as indicated for VCO 1 using VCO 2 V/OCT R78 trimmer. <p>*Note: If VCO 1 V/OCT adjustment has been accurately made then VCO 2 can be adjusted audibly by comparing its pitch to VCO 1.</p>
R97	VCO 3 V/OCT	<ol style="list-style-type: none"> 1. Repeat procedure as indicated for VCO 1 and VCO 2 using R97 (VCO 3 V/OCT) trimmer.

3.3 Board 1 Adjustments

3.3.1 RING MODULATOR

R33	Positive Null	<ol style="list-style-type: none"> 1. Put audio/d.c. switch to d.c. position. 2. Raise VCO 2 slider into the Ring Modulator only. 3. Monitor Ring Modulator output with oscilloscope and adjust R33 (middle trimmer) for minimum output (should be less than 10mv).
R34	Negative Null	<ol style="list-style-type: none"> 4. Put audio/d.c. switch to audio position and adjust R34 (lower trimmer) for minimum output (should be less than 10mv).
R35	Gain	<ol style="list-style-type: none"> 5. Raise both sliders into Ring Modulator and select audio/d.c. switch to d.c. 6. Adjust R35 for 20V P.P. maximum.

3.4 Board 2 Adjustments

3.4.1 VCO 1 PULSE WIDTH ADJUST

R18	Pulse Width	<ol style="list-style-type: none"> 1. Monitor VCO 1 square wave output with an oscilloscope and adjust R18 for exactly 50% duty cycle (square wave). (Located below VCO 1 Fine Frequency Slider.)
-----	-------------	--

power amp output through R344. The positive portion of the wave on the output of A40 controls the current through Q30 and the negative portion of the signal passes through CR46 and CR45 to control the current through Q32. The complete

amplified signal is at the junction of R346 and R345. Q34 limits the current through the negative portion of the power amp. Outputs 'A' and 'B' go directly to the 40 ohm speakers.

SECTION 3 CALIBRATIONS

The following section includes all the calibrations in the 2600.

3.1 Power Supply Adjustment

NOTE: THIS ADJUSTMENT MUST BE PERFORMED PRIOR TO MAKING ANY OTHER CALIBRATIONS.

1. Connect a Digital Voltmeter across the plus 15.00 connection and ground (red and black wire).
2. Adjust R10 for exactly +15.00VDC.
3. Connect the DVM across the negative supply connection and ground (black and violet).
4. Adjust R13 for exactly -15.00VDC.

3.2 2600 Tuning

3.2.1 VOLTS PER OCTAVE DEFINITION

Tuning the 2600 requires the frequency of the oscillator to exactly double for each volt applied to the control input. The 'Volts per Octave' trimmer, located above the calibrate trimmer, adjusts the input of the oscillator for this response. For example, when an oscillator is tuned initially to 100Hz., with low 'C' depressed, (zero volts supplied to the oscillator), the highest 'C' would produce 1600Hz. (four volts supplied to the oscillator).

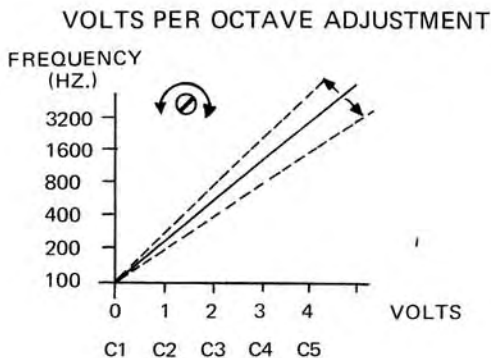

3.2.2 TRACKING DEFINITION

Oscillators which are tracking together will maintain

the same relative frequency difference regardless of which key is depressed. If they are not tracking properly, oscillators in tune with each other on the lowest note will not be in tune with each other on the highest note.

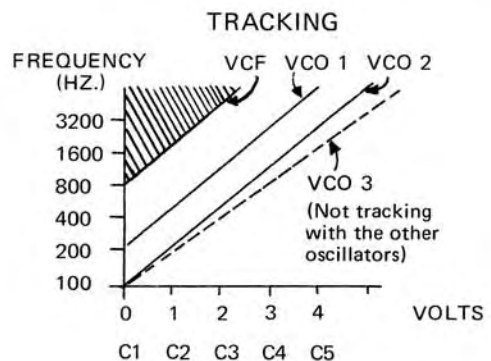

3.2.3 TYPES OF OSCILLATOR MODULES

Several types of oscillator modules have been used in the 2600: the 4017, 4027, and most recently, 4027-1. They are equivalent except for the 4017 and 4027 modules require an external high frequency compensating trimmer to prevent the pitch from going flat at higher frequencies. The 4027-1 is internally compensated so this trim is unnecessary.

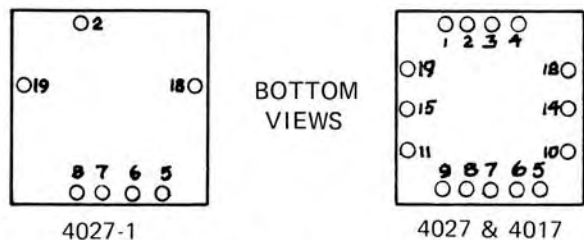

The 4017 and 4027 have from 15 to 18 pins, the 4027-1 has only 7. (Some units containing the 4027-1 may still have the high frequency track trimmer on the board, but it is not connected to the module.)

3.2.4 REPLACEMENT

The 4027-1 replaces all other oscillator modules. If only one module is to be replaced in a unit containing the 4017 or 4027 modules, follow the 4027-1

2.6 Noise Generator, Voltage Processor, Sample & Hold, Internal Clock, Amplifier

2.6.1 NOISE GENERATOR (Module 4022)

The Noise Generator provides a +20 volt peak to peak noise signal of about 10 octaves bandwidth. The right Noise Generator slider controls the amplitude of the noise and the left slider controls the noise color. As the color slider is lowered from top to bottom, the higher frequencies in the noise are attenuated. The output from the Noise Generator is prewired to the VCF, VCO 2, and VCO 3, and the Sample and Hold.

The source of the noise is an amplified, reversed junction of a selected transistor (Q1 on the 4022 module). Z1 amplifies and clips the noise to 10 volts peak to peak. A35 (on board 5-1) filters out the higher frequencies of the noise signal leaving only a low frequency noise signal. The noise color slider pans from the output of the low frequency noise filter (A35) to the output of the 4022 (pin 5). A36 amplifies and buffers the final noise signal.

2.6.2 VOLTAGE PROCESSOR

The top inverter has two attenuated inputs and two fixed inputs which are useful for mixing voltages or signals. The gain from either of the attenuated inputs is adjustable from 0 to -1. The fixed inputs are calibrated for a gain of -1 exactly. The upper attenuated inputs of the inverter are prewired to -10 volts and will produce a +10 volts on the output when the slider is fully right. The lower attenuated input is prewired to the Keyboard Control Voltage and will produce a negative complement of the Keyboard Control Voltage output when the slider is fully right.

The second inverter is the same as the upper inverter except that it has one attenuated input and one fixed input. The attenuated input is prewired to +10 volts and will produce -10 volts on the inverter output when the slider is fully right.

The lag processor acts to smooth out sharp rising and falling voltages. When the slider is fully left, lag time constant is about .05 milliseconds. When the slider is fully right, the delay is about .5 seconds. The lag processor is used whenever a low frequency signal needs to be filtered or rounded out. The input is prewired to the output of the Envelope Generator.

2.6.3 SAMPLE & HOLD (MODULE 4015).

The S/H provides a stepped output voltage by

sampling and storing the instantaneous voltage level of the input signal each time it receives a trigger pulse. This stored voltage is held until the next trigger pulse occurs. The S/H trigger input is prewired to the Internal Clock but the S/H can be triggered from any sharply rising waveform. The S/H input is prewired to the Noise Generator output. The left S/H slider (level) attenuates the input signal before it is sampled, thus lowering the average voltage level on the S/H output. The right slider (rate) does not actually belong to the S/H, but it controls the rate of the Internal Clock which may be used to supply a trigger; and, therefore, controls the sample rate.

The signal that is to be sampled enters pin 1 of the 4015 module through the level slider on the 5 board. The pulse that instructs the module to sample the voltage of the signal on pin 1 enters the module on pin 4. C119 and R392 differentiate any sharply rising waveform to produce a suitable trigger pulse shape. Pin 5 of the 4015 module is the S/H output.

2.6.4 INTERNAL CLOCK

The clock is a low frequency square wave oscillator whose frequency is determined by the position of the rate slider. The clock trigger output is hardwired to the S/H and the Electronic Switch and has a separate square wave output which is also wired to the clock output jack, and the shunt of the external gate input jack (under the gate select switch).

Q45, a uni-junction transistor, and capacitor C115 comprise a relaxation oscillator. When C115 reaches the threshold of Q45 (about -5V), Q45 discharges C115 through R383 to -15V. The charge path of C115 is through R313 (clock rate slider) and Q44. A42, a comparator, converts the sawtooth signal on C115 to a 30 volt peak to peak square wave whose duty cycle is determined by the position of R385 (pulse width adjust). The output of A42 routes the signal through CR47 to the S/H and the Internal Clock Output.

2.6.5 AMPLIFIER

Two power amplifiers are included in the 2600 to drive the left and right monitor speakers. The power amplifier is driven directly from the left and right output jacks and has no available output on the front panel, other than the speakers and headphone jack.

The signal from the preamps (connected through the speaker level sliders) enter the power amp circuitry through C104 and R341 to the inverting input of A40. The feedback for the op amp is from the

rise and fall times. It is used primarily to control the VCA and the VCF. When the ADSR is supplied with a gate and a trigger (from either the keyboard, internal clock, or the manual start button), the voltage first rises to 10 volts (Attack) and then decreases to a predetermined level (Decay) and remains there (Sustain) while the gate signal is present. Finally, the voltage decreases to zero (Release) when the gate is removed. The attack time, initial decay, sustain level and the final release are each controlled by the four sliders on the front panel.

Q2 (4020 board) is turned off unless there is a gate signal present on pin 2 of the 4020 board. In the off state, Q2's collector voltage is high, which holds on Q7, the trigger enable. As long as Q7 is on, all trigger signals entering on pin 1 of the 4020 board are grounded out which prevents the ADSR from initiating an attack when no gate is present. When a key (or the manual start button) is depressed, the gate signal turns on Q2 through Q1. The voltage on the collector of Q2 drops to -15 volts, Q3 turns off, and Q7 turns off which allows the trigger signal to enter through C4 and R20. The keyboard trigger, which is delayed by the keyboard electronics, arrives on the base of Q8 (4020 board) 15 milliseconds after the rise of the gate voltage. The trigger turns on Q8 which turns on Q6. The collector of Q6 rises and latches Q8 and Q6 on through CR8. The voltage on the collector of Q6 also travels through CR6, R12 and R179 (attack slider) and begins to charge up C1 and C2. A1 buffers and follows the voltage level on C1 and C2; when the voltage reaches +10 volts, Q5 turns on which turns on Q7 through CR4 and R18. Q7 then grounds out the voltage on the base of Q8 thus unlatching Q8 and Q6. When Q6 turns off, CR7 is reversed biased which allows Q4 to turn on. The +10 volts on C1 and C2 discharges through the decay slider, R180, to the voltage level present on C68 (on board 4). Q6 (on board 4) holds C68 to a voltage level determined by the position of the sustain slider, R181. When the gate voltage is removed, Q2 turns off and the voltage on the collector of Q2 rises which turns off Q4 through CR3 and turns on Q3 through CR1. The remaining voltage on C1 and C2 discharges to ground through the release slider, R182.

2.5.4 MIXER, PREAMP

The Mixer is a general purpose mixer useful for audio or DC signals. Its output goes directly to the pan slider through the pan output jack and to the reverberator input. The two inputs of the mixer are prewired to the VCF and the VCA. The jacks above

the mixer input sliders will disconnect the slider from the mixer input when a patch cord is inserted so that the slider can be used as general purpose attenuators in other functions of the 2600. The outputs of the pan slider go to the left and right preamplifiers.

Signals enter the mixer circuitry through either slider R200 or R201. The signals then pass through R202 and R203 into the inverting input (pin 2) of A25 on the 4-2 board. The signal then goes to the pan slider and to the reverberator input jack. At the pan slider, the signal splits into two channels; left and right. When the pan slider is moved from left to right the arm of the slider grounds our right channel and then the left thus producing a pan effect. The right signal passes through R256 into the inverting input (pin 2) of A27. A27 buffers and amplifies the signal and delivers it to the right output jack and also to the right power amplifier for the right internal speaker. In the same manner, the left channel signal leaves the pan slider through R255 and enters the inverting input jack and to the left power amplifier for the left internal speaker.

2.5.5 REVERB (BOARD 4-2)

The Reverb circuit has one input that is prewired to the Mixer output. The Reverb circuit also has two outputs; the left is wired directly to the left preamplifier and the right output is wired through the reverb output jack to the right preamplifier.

A signal entering the reverb circuit through the reverb input jack is AC coupled by C89 and enters the inverting input, pin 2 of A28 (on board 4-2) through R272 and R273. From the output of A28 (pin 6) the positive portion of the signal passes through CR41 and CR40 and is amplified and inverted by Q26. The negative portion of the signal is amplified and inverted by Q27. The complete amplified wave then passes through R281 to the reverb spring driver (located on the bottom of the console case) to give the reverb effect. The other end of the reverb springs (the pick up) is AC coupled through C94 to pin 2 of A30 which amplifies the signal and sends it to the two reverb sliders. There the two signals are split into the different channels, left and right. The left channel signal goes directly from the reverb slider to A29 where it is amplified and mixed with the left mixer signal. The right reverb signal goes directly to the noninverting input (pin 3) of A31 where it is amplified and sent to the reverb output jack. The shunt of the reverb output jack is wired to the input of A27 so the right reverb signal can normally be mixed with the right mixer signal.

and will pass all audio and DC signals applied to its input. When the fc is set to the lowest frequency, the filter is said to be 'closed' and it will completely attenuate all audio frequencies.

The fc can be controlled manually by the Initial Frequency Slider and the Fine Tune Slider as well as by control voltage signals applied to the control inputs. The fc range is adjustable from 10Hz. to 10KHz. without external inputs and can be made as low as 1Hz. or as high as 20KHz. with additional negative or positive control voltages. The keyboard is prewired to the VCF control input through the 1V/OCT trimmer which is tuned so that the fc of the filter tracks the frequency of the oscillators.

The 'Q' (resonance) is controlled manually by the resonance slider. The resonance accentuates a narrow band of frequencies which produces a 'wow' effect when the fc is varied. When the Q is at maximum, the VCF will oscillate, producing a sine wave, and can be used like the other voltage controlled oscillators.

The filter's five audio inputs are prewired to the Ring Modulator, VCO 1 square wave, VCO 2 pulse wave, VCO 3 sawtooth wave, and the noise generator.

Audio signals enter the VCF Circuitry through the five audio attenuators, R140 through R144. Pin 1 of the 4012 module is the audio input summing junction. The output of the module is pin 5. The Resonance Slider, R160, allows some of the output signal to feed back into the input through pin 2. R163 CONTROLS THE GAIN OF THE VCF and R162 eliminates the DC from the output. The control voltages (or signals) enter the circuitry through the sliders R145 - R147. Pin 3 and 11 are the control inputs. R156 and R158, the Initial Frequency and Fine Tune Sliders, add voltage to the control inputs to increase the fc. R164 sets the fc when there are no external control signals. R153 (volts per octave) sets the sensitivity of the VCF so that it will track with the other oscillators.

2.5 Board 4 VCA, AR, ADSR, Mixer, Reverb, Preamp

2.5.1 VOLTAGE CONTROLLED AMPLIFIER

The VCA controls the amplitude of a signal passing through it. When the initial gain slider on the front panel is at maximum, the signal will pass through the VCA with no change in amplitude (unity gain). If the gain slider is at a minimum, no signal will pass through the VCA unless a positive control voltage is applied to either of the two control inputs. The sensitivity of the left control input is linear but the response of the right control input is exponential. The left control input is prewired to the AR and the

right control input is prewired to the ADSR output.

There are two audio inputs to the VCA; the left input is noninverting and the right audio input is inverting. Thus, a positive going sawtooth wave applied to the right audio input produces a negative going sawtooth wave on the output of the VCA. The left audio input is prewired to the VCF output and the right audio input is prewired to the Ring Modulator output.

Pin 1 is the noninverting audio input and pin 2 is the inverting audio input of the 4019 module. Pin 3 is the linear control input and pin 4 is the exponential control input. R196, the linear gain trimmer, sets the sensitivity of the linear input and R195, the exponential gain trimmer, sets the sensitivity of the exponential control input (this trimmer is always set in the fully clockwise position). R198, the initial gain slider, adds voltage to the linear control input to allow signals to pass through the VCA without external control voltages. The control reject trimmer, R193, eliminates any leakage of the control voltage into the output of the VCA. The high frequency reject trimmer, R194, is designed to minimize unwanted high frequency noise from the output of the VCA. Often there is too little high frequency noise to warrant adjustment of this trimmer. Pin 5 of the 4019 module is the audio output of the VCA.

2.5.2 ATTACK RELEASE

The Attack-Release (AR) envelope generator produces control voltages with variable rise and fall times. It is used primarily to control the VCA. When the AR is supplied with a Gate signal from the manual start button, keyboard or internal clock, the output rises to 10 volts and stays at that level for the duration of the gate signal. When the gate is no longer present, the voltage decreases to zero. The attack time and the release time are manually controllable by the sliders on the front panel.

The gate voltage passes through R172, CR25 and the attack slider (R174) and charges C69 to 10 volts. The charge time is determined by the position of the Attack Slider, R174. At the same time, the gate signal turns off Q5 through R214 so the C69 cannot discharge through it while the gate is present. When the gate is no longer present, Q5 turns on and C69 discharges through Q5 and the Release Slider, R175. A20 follows the voltage level on C69 and buffers it from the output.

2.5.3 ATTACK DECAY SUSTAIN RELEASE MODULE (4020)

The Attack Decay Sustain Release (ADSR) envelope generator produces control voltages with variable

2.3.1 VCO 1

VCO 1 generates a sawtooth wave and a square wave. The keyboard control voltage, sample and hold, ADSR, and VCO 2 sine wave are prewired to the frequency control inputs of VCO 1.

Pin 2 of the 4027-1 oscillator module is the control current summing point. Current applied to this input controls the frequency of the oscillator. Pin 5 is the sawtooth wave output of the module. From this output, the signal goes directly through to the sawtooth output jack through R106 and to the square wave converter through R47. Pin 18 allows an external capacitor to be connected to the oscillator so that it will operate at very low frequencies. Pin 19, the calibrate input, is internally connected to a trimmer, R52, so that the normal frequency of the oscillator can be tuned. When the range slide switch, S4, is in the 'audio' position, the Keyboard Control Voltage is connected to the control summing input through R56 and the V/OCT (volts per octave) trimmer, R60. When the range slide switch is in the low frequency position, one terminal of C40 is grounded, adding capacitance from pin 18 to ground, thereby lowering the operating frequency of the oscillator. In addition, the negative current is simultaneously allowed to enter the control input of the oscillator through R53, also lowering the frequency.

A8 is the sawtooth to square wave converter; a fixed voltage of about five volts is applied to the noninverting input of A8 (pin 3) from the symmetry trimmer, R18. The 10V P.P. sawtooth wave from the module is applied to the inverting input (pin 2) of A8. A8 is a comparator which compares the sawtooth wave against the voltage supplied by the symmetry trimmer, R18. CR7 rectifies the output of A8 so the pulse wave is positive going only. R50 and R51 reduce the amplitude of the pulse wave to about 10 volts, peak to peak.

2.3.2 VCO 2

VCO 2 generates sawtooth, pulse, triangle and sine waveforms. The width of the pulse wave can be controlled either by the pulse width slider or by a control voltage applied to the pulse width modulation input. This input is normally prewired to the Noise Generator output. The Keyboard Control Voltage, Sample and Hold, ADSR, and VCO 1 square wave outputs are prewired to the frequency control inputs of VCO 2.

The 4027-1 oscillator is exactly the same as the 4027-1 module in VCO 1. The difference between the two oscillators is in the waveform converters.

Pulse Converter: The pulse converter on VCO 2 is similar to the square wave converter on VCO 1.

The sawtooth wave from the 4027-1 module enters board 2-1 (the waveform converter board) on connector pin 2 and enters the inverting input of A15 through R109. A15 is a comparator which compares the sawtooth wave against the output of A14. A14 sums the voltage from the pulse width control (R20) and the pulse width modulation signal entering through slide pot R82. CR14 rectifies the output of A15 so that the pulse wave is positive going only. R116 and R118 reduce the amplitude of the pulse wave to about 10 volts, peak to peak.

Triangle Converter: Q1, Q2, and A16 convert the sawtooth to a triangle wave. The sawtooth wave passes through R113 to Q1, an emitter follower. R115, the symmetry trimmer, sets the DC offset of the sawtooth at the emitter of Q1. As the voltage at the base of Q2 rises from 0V to about +5V, Q2's collector voltage drops from +10V to +5V. As the voltage at Q2's base rises from +5V to +10V, the base-collector junction of Q2 becomes forward biased and the voltage at Q2's collector, heads back toward +10V. A16 amplifies the resulting 5V P.P. triangle wave to about 20 volts peak to peak and R125 removes the DC component. R132 and R133 attenuates the output to 10 volts peak to peak.

Sine Converter: The triangle wave at the output of A16 is applied to the sine wave converters, Q3 and A17, through attenuator R121 (purity trimmer). Q3's nonlinearity rounds the peaks of the triangle to approximate a sine wave. A17 amplifies the signal from Q3 to 10 volts peak to peak.

2.3.3 VCO 3

The 4027-1 oscillator module is exactly the same as the module in VCO 1. The pulse wave converter of VCO 3 is exactly like the square wave converter of VCO 1 except that the symmetry trimmer is replaced by a slider on the front panel for manually variable pulse width control.

R92, the pulse width slider, sets the exact level of the voltage on the noninverting input of A9 and is used to set the duty cycle of the pulse wave on the output of A9. CR8 rectifies the output of A9 so that the pulse wave is positive going only. R104 and R89 reduce the amplitude of the pulse wave to about 10 volts, peak to peak.

2.4 Board 3 VCF 4012

The VCF is a 24db/octave low pass filter with a variable cutoff frequency (fc) and resonance (Q). As the fc is decreased, the higher harmonics of a signal are attenuated until only the fundamental frequency is audible. The fc of the filter is variable from approximately 10Hz. to 10KHz. When the fc is set as high as possible the filter is said to be 'open'

-15 Volt Supply: Q1, Q2 and CR1 are the voltage regulators for A1. The -15 volt supply derives its regulation from the +15 volt supply through R11 to the inverting input of A2, the -15 volt comparator. The output of A1 controls Q5, the -15 volt current amplifier. Deviations in the output voltage are reflected through R11 back to the inverting input of A2. The noninverting input of A2 is referenced to ground through R4.

-15 Volt Current Limiting: When enough current flows out of the negative supply to cause .7 volts drop across R15, Q3 turns on effectively shorting the base of Q5 to the output voltage of the -15 volt supply. Q5 in turn supplies less current to the output.

ADJUSTMENT

NOTE: THIS ADJUSTMENT MUST BE PERFORMED PRIOR TO MAKING ANY OTHER CALIBRATIONS.

1. Connect a Digital Voltmeter across the plus 15.00 connection and ground. (red and black wire)
2. Adjust R10 for exactly +15.00VDC.
3. Connect the DVM across the negative supply connection and ground. (black and violet)
4. Adjust R13 for exactly -15.00VDC.

2.2 Board 1 Preamplifier, Envelope Follower, Ring Modulator

2.2.1 PREAMPLIFIER

The microphone preamplifier accepts any low to medium level external input. A rotary control serves as an input attenuator and a three position slide switch selects one of three gain ranges: X10 (20db), X100 (40db) and X1000 (60db). The preamplifier is useful with microphones, electronic musical instruments, and any other signals which do not have adequate signal level to drive the 2600 circuits directly.

The signal to be amplified enters the preamplifier circuit through R23, the gain control, and is coupled through C24 to the noninverting input (pin 3) of A4. The range switch, S1, selects the feedback path for A4 through either R20 for X10, R20 and R26 for X100 or R20, R25 and R28 to ground for X1000. The amplified signal then passes from pin 6 of A4 through R27 to the output jack.

2.2.2 ENVELOPE FOLLOWER

The envelope follower generates a positive DC voltage output which is directly proportional to the amplitude of the audio input signal. The envelope follower's sensitivity is such that a 2 volt peak to peak signal will produce about 5 volts DC on the output with the input slider fully up. The preamplifier is prewired to the envelope follower input.

A1, CR2, CR1, and A2 comprise a full wave rectifier for the audio signal. The positive portion of the wave on pin 6 of A1 goes through CR2 and into the non-inverting input of A2 (pin 3). The negative portion of the wave passes through CR1 to the inverting input (pin 2) of A2 so that the output of A2 is always positive. The rectified signal on pin 6 of A2 is then filtered by R12-15 and C7-10 and then amplified and buffered by A3.

2.2.3 RING MODULATOR

The Ring Modulator is an analog multiplier which accepts two different signals and multiplies them to form a single complex wave. In the 'audio' mode, the DC component of each of the input signals is cancelled before it reaches the modulator. In the DC mode, the output voltage of the ring modulator will be the product of the two input voltages divided by 5. The Ring Modulator is useful for producing bell or gong sounds. In the DC mode, it can also be useful as a second voltage controlled amplifier by applying a control voltage to one input and an audio signal to the other input. The Ring Modulator will pass the audio signal with an amplitude proportioned to the control voltage. VCO 1's sawtooth output is prewired to the left input and VCO 2's sine wave output is prewired to the right input.

2.3 Board 2, 2-1 VCO 1, VCO 2, VCO 3

GENERAL

The voltage controlled oscillators generate a sawtooth wave whose frequency is determined either manually (by moving the initial frequency sliders) or by control voltages from the keyboard, other oscillators, envelope generators, etc. The sawtooth wave is converted to other wave shapes, such as square, pulse and sine waves. When the range switch of the oscillator is in the lower position (LF, KYBD OFF) the oscillator produces sub-audio frequencies which are useful as control signals.

SECTION 1 GENERAL

1.1 Prewired Patches

The 2600's prewired patches provide the most popular synthesizer effects without the use of patch cords by using the closed circuit tip and shunt of mini jacks. This internally 'prewired' patch may be overridden however, by inserting a patch cord into the appropriate panel jack. Note that a circle in the block diagram indicates a mini jack.

1.2 Synthesizers in General

Synthesizers include three types of circuits: 1) signal sources, 2) signal modifiers, and 3) controllers. In general, sounds are produced by a synthesizer in the following manner:

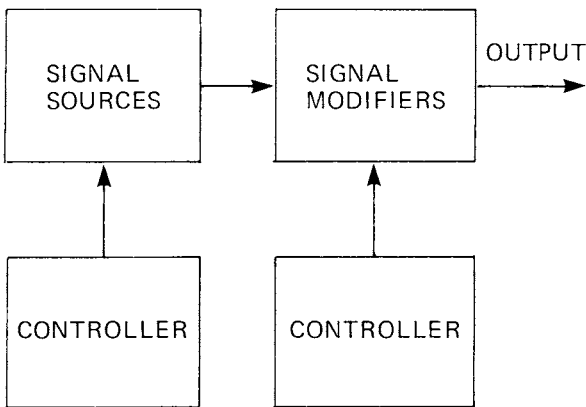

A 'raw' signal is produced by a signal source, such as an oscillator or noise generator. The tone or color of the raw signal is then shaped as the signal passes through the modifier which in the 2600 could be the ring modulator, VCF or VCA. Controllers are used to give automatic variations in the pitch of the signal source and/or the operating characteristics of the modifier.

Although many functions on the 2600 can be used as both controllers or signal sources, the following table suggests the most common use of each function on the 2600:

SOURCES	MODIFIERS	CONTROLLERS
VCO 1	VCF	ADSR
VCO 2	VCA	AR
VCO 3	RING MODULATOR	KEYBOARD
NOISE GENERATOR	ELECTRONIC SWITCH	ENVELOPE FOLLOWER
	REVERB	SAMPLE AND HOLD
	INVERTERS	VCO's IN LF RANGE
	LAG PROCESSOR	INTERNAL CLOCK
	MICROPHONE PREAMP	

SECTION 2 CIRCUIT DESCRIPTION

This section is to be used as an aid in circuit analysis. Some trouble shooting hints are provided for certain boards in Section 6 (page 13).

2.1 Power Supply

Voltage Source: BR1, a full wave bridge rectifier, supplies about 30V, (plus and minus), to the regulating circuitry. C1 and C2 filter out ripple on the supply lines.

+15 Volt Supply: A1 contains a voltage reference which supplies about 7.0 volts to pin 6 of A1. This fixed voltage is connected through pin 5 to the non-inverting input of a comparator. The output of the comparator is connected to an emitter follower, also located inside A1, which controls Q4, the current amplifier. The power supply normally delivers +15 volts to the output; if the voltage should change, the voltage at the junction of R7 and R9 will also change.

The resistor junction is connected to the inverting input of the comparator through pin 4 of A1. If the voltage at this point should drop, the output of the comparator will rise, turning on the emitter follower and the pass transistor, thus raising the output voltage. Similarly, if the voltage at the resistor junction should increase, the comparator will initially limit the current through the pass transistor and lower the output voltage. R10, the +15 volt trimmer, initially sets the voltage level on the output of the supply.

+15 Volt Current Limiting: When enough current flows out of the positive power supply to cause a .7 volt drop across R6, the transistor connected to pins 2 and 3 of A1 turns on, effectively shorting the base of the emitter follower to the output voltage of the +15 supply. Q4 in turn supplies less current to the output.

3.4.2 FREQUENCY CALIBRATE

Ref. No.	Trimmer	Specifications/Trim Procedure
R52	Frequency Calibrate VCO 1	<ol style="list-style-type: none"> 1. Monitor VCO 1 output with an oscilloscope or frequency counter. 2. All FM sliders down. 3. Remove Keyboard CV from VCO 1 or use dummy plug in VCO 1 CV jack. 4. Put course frequency slider - far right (maximum). 5. Put fine tune slider - mid range. 6. Adjust R52 for 8.33KHz.
R68	Frequency Calibrate VCO 2	<ol style="list-style-type: none"> 1. Monitor VCO 2 output with an oscilloscope or frequency counter. 2. Repeat same procedure as described for VCO 1 calibrate using R68.
R87	Frequency Calibrate VCO 3	<ol style="list-style-type: none"> 1. Monitor VCO 3 output with an oscilloscope or frequency counter. 2. Repeat same procedure as described for VCO 1 calibrate using R87.

3.4.3 VCO 2 *BOARD 2-1 ADJUSTMENTS (see pg. 22 for pot. location)

R115	Symmetry Adjust	<ol style="list-style-type: none"> 1. Monitor VCO 2 triangle output with an oscilloscope. 2. Adjust R115 for best triangle waveform.
R125	DC Offset Adjust	<ol style="list-style-type: none"> 3. Adjust R125 so the peaks of the triangle waveform are not flat at either end.
R128	Gain Adjust	<ol style="list-style-type: none"> 1. Monitor VCO 2 sine wave output with an oscilloscope. 2. Adjust R128 for 10V P.P. output.
R121	Purity Adjust	<ol style="list-style-type: none"> 3. Adjust R121 for the best sine waveform.

**NOTE: It may be necessary to readjust calibrations after performed in the order listed.*

3.5 Board 3 Adjustments - Voltage Controlled Filter

3.5.1 FREQUENCY CALIBRATE

R164	Frequency Calibrate	<ol style="list-style-type: none"> 1. Monitor VCF output with an oscilloscope or frequency counter. 2. Initial frequency slider - left. 3. Fine tune slider - mid range. 4. Resonance slider - right. 5. All VCF input sliders - down. 6. Disconnect keyboard or use dummy plug in 'VCF KYBD CV' jack. 7. Adjust R164 for 10Hz. output.
------	---------------------	--

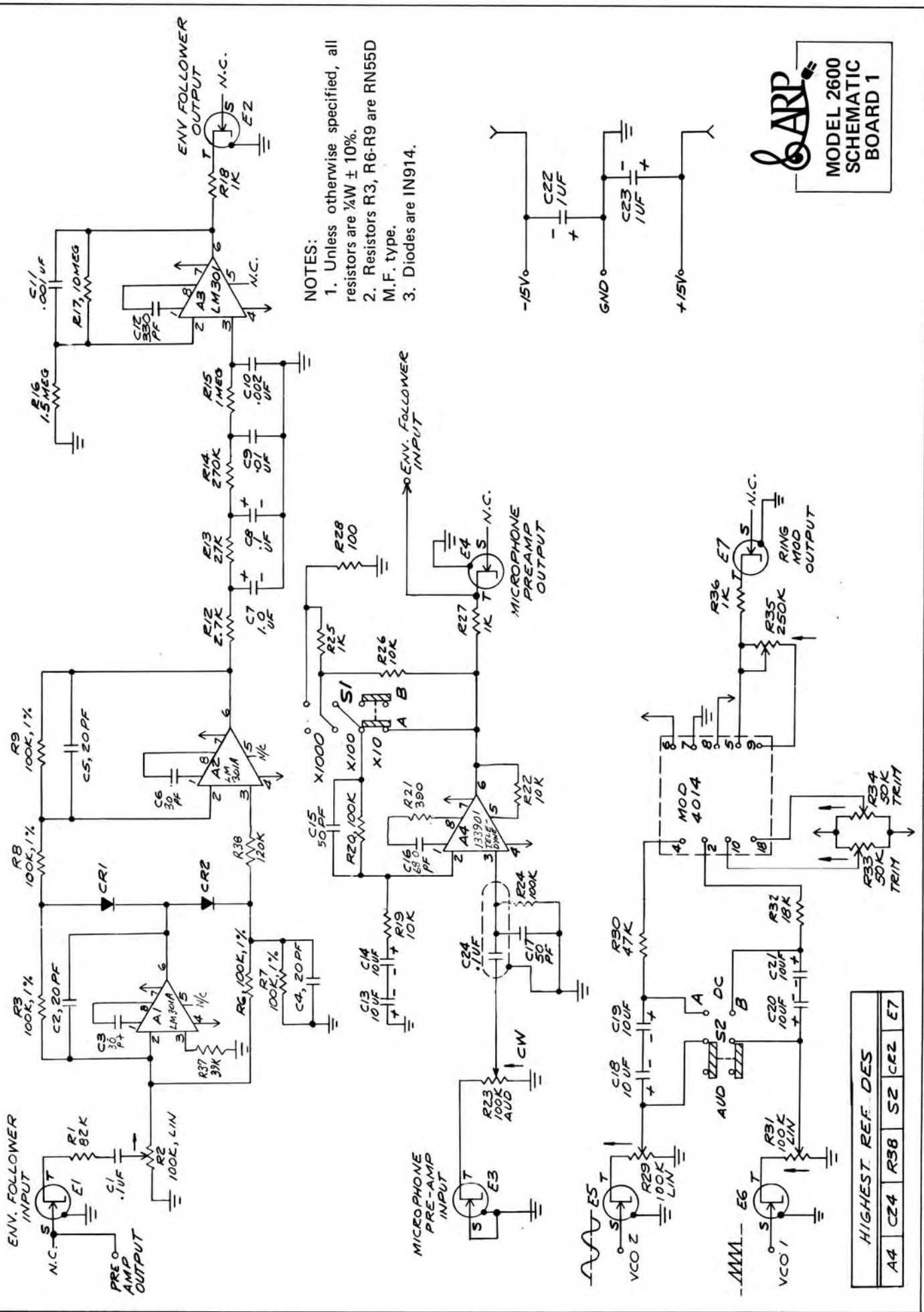

NOTES:

1. Unless otherwise specified, all resistors are 1/4W ± 10%.
2. Resistors R3, R6-R9 are RN55D M.F. type.
3. Diodes are IN914.



**MODEL 2600
SCHEMATIC
BOARD 1**

BOARD LOCATION DIAGRAM
PANEL FACE DOWN VIEW

POWER SUPPLY

5 BOARD

5 - 1 BOARD

S/H
4015

NOISE
4022

S/H
4015

1 BOARD

RING MOD
4014

2 BOARD

2 - 1 BOARD

3 BOARD

VCF
4012/
4072

4 BOARD

ADSR
4020

MIX - PAN
4 - 2 BOARD

VCA
4019

VCO 3
4027 - 1

VCO 2
4027 - 1

VCO 1
4027 - 1

VCA
4019

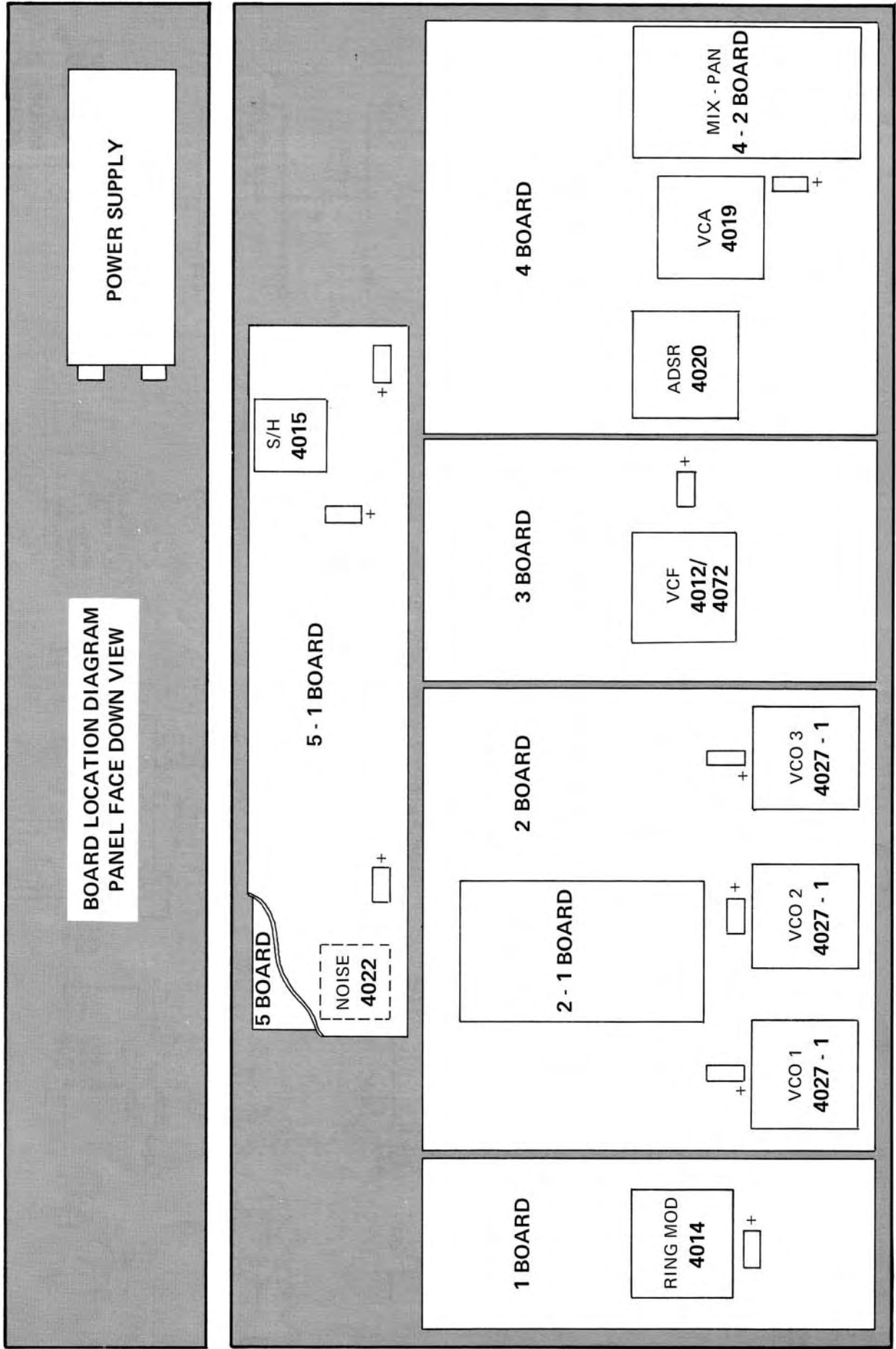

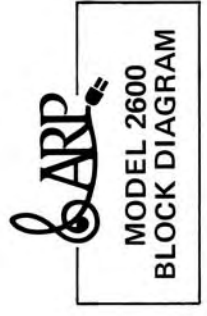
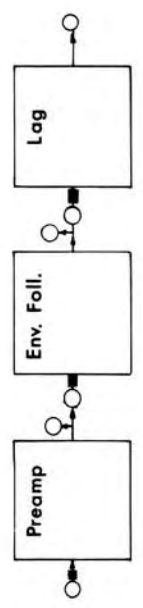
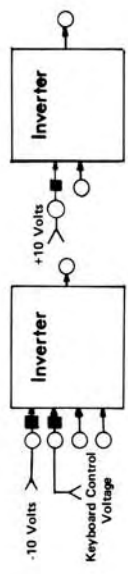
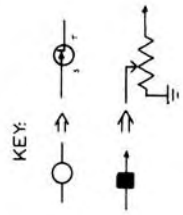
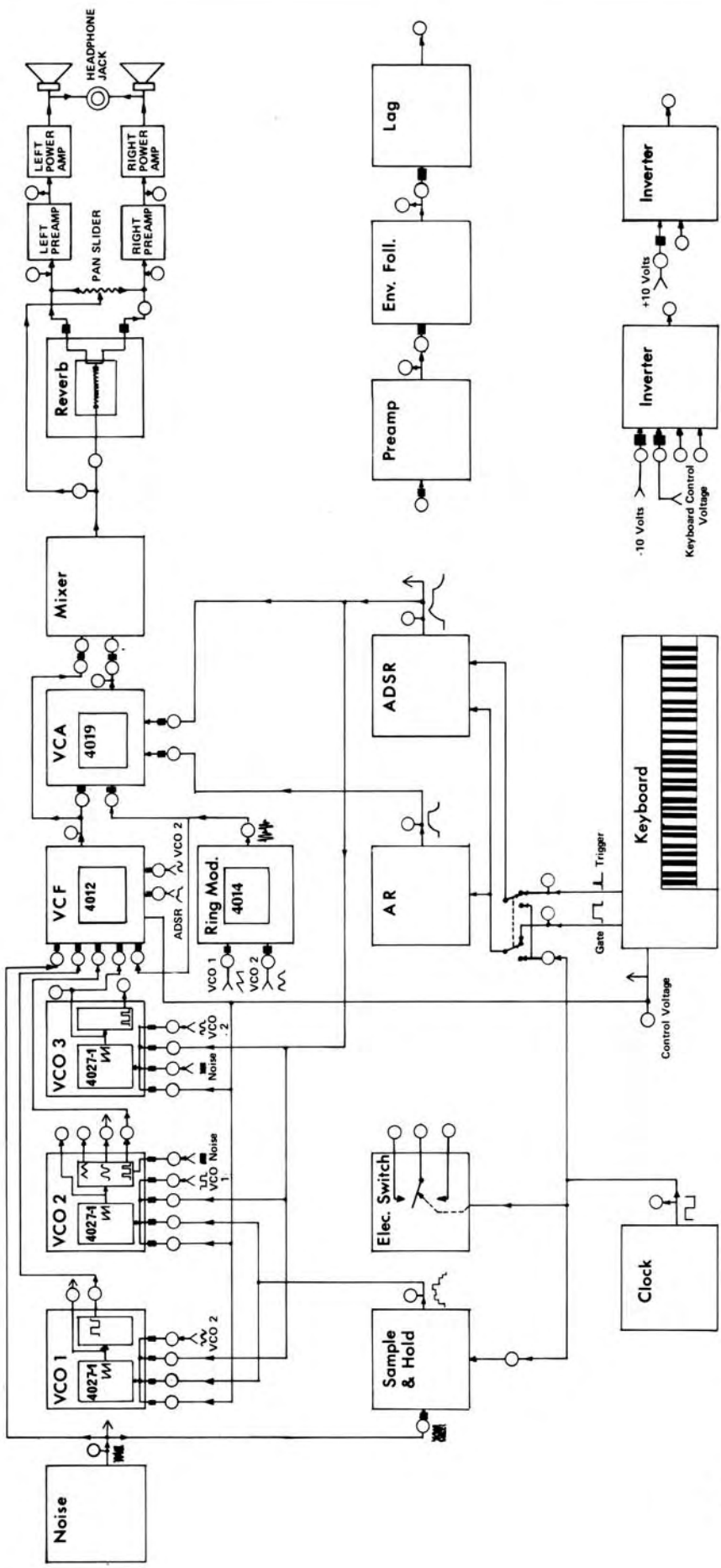

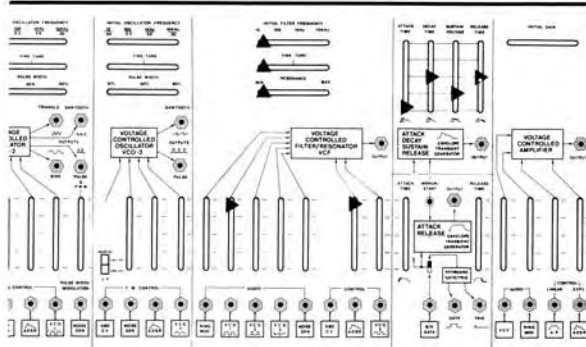

1. Raise VCO 1 slider into the filter and close VCF initial and fine tune sliders.
2. Raise the ADSR control slider.
3. Select ADSR settings so that a sharp envelope occurs when a key is depressed.
4. Listen to the output of the filter through the Monitor speakers while depressing each key sequentially from left to right.
5. Each key should produce a well-defined sharp pulse of sound. If not, then either the sequence of contact closures is incorrect or the contacts and/or bus bar are dirty.
6. Contacts and bus bars should be cleaned with Trichlorethylene, denatured alcohol or some other 0 residue cleaner.

3604P V/OCT ADJUSTMENT

1. Pin low 'C' on the keyboard while monitoring the 'KBD CV' output jack on the console.
2. Adjust trimmer on A1 module for 0 Volts output. Note: some of the older style 3604P keyboards contain the encapsulated module. If so, adjust R19 trimmer on the keyboard for 0 Volts.
3. Depress high 'C' and adjust the fixed interval pot (2.5Kohm) for exactly 4.00 Volts. (Be sure Interval switch on panel is selected to the right when making this adjustment.)

6.2.3 CONTACT ADJUSTMENTS

To adjust the contacts, use a small screwdriver at the base of the spring contact. Pivot the screwdriver against the base of the spring by anchoring one edge of the screwdriver on the P.C. board. This will give you the control you need to adjust the contacts without bending them too far.

CONTACT SPRING ADJUSTMENTS

Clean the contacts with denatured alcohol before adjusting them.

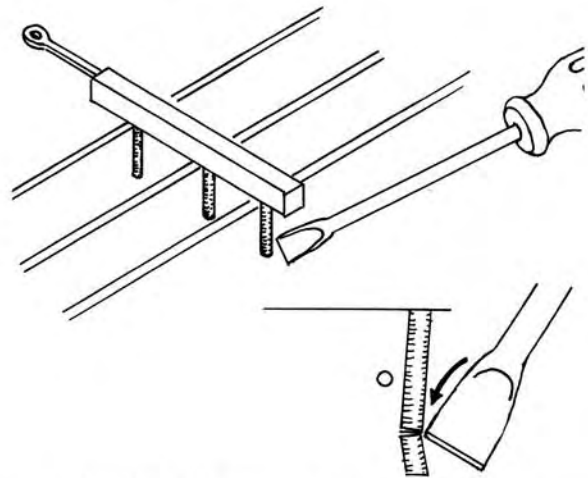

CAUTION: IMPROPER ADJUSTMENT WILL CAUSE SPRING BREAKAGE.

MODIFICATIONS

3620 Modification

Older style keyboards (3604P) can be converted to the new 3620. These modifications are only available at the Factory by appointment only — cost; \$350. Included with the modification is a portamento/interval footswitch and a one full year warranty. Call the Factory for more details.

4012 to 4072 Filter Conversion

The 4012 to 4072 Filter conversion is available for all 2600's. See Section 5 page 12 for installation information.

110 Volt to 220 Volt Conversion

1. Remove the 115 V wire from the terminal strip.
2. Solder the 220 V wire to the terminal strip.
3. Change the fuse to ¼ amp, slow blow.

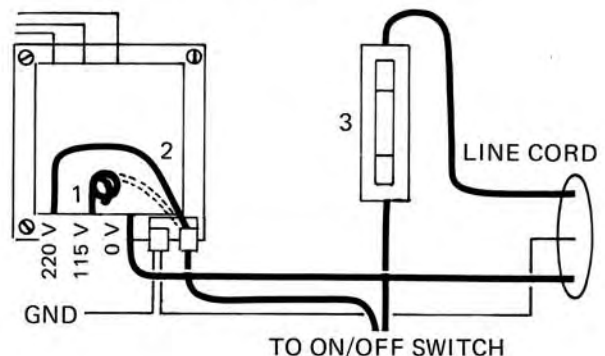

Power Supply loads down. (output is less than plus or minus 15V)

1. Remove Power Supply connector from P.C. board one at a time to determine which board is at fault.
2. After faulty P.C. board has been determined, remove the Power Supply molex pins one at a time to determine whether the plus or the

minus supply is at fault.

3. Inspect closely for solder splashes or bridges.
4. Locate active components on board and inspect for overheating.
5. If unable to determine fault then it may become necessary to remove each of the suspected active components, one at a time.

SYMPTOM	PROBLEM	REPAIR	LOCATION
OUTPUT OF VCF AT +15 VOLTS	VCF OUTPUT OFFSET INCORRECTLY SET	SEE SECTION 3.4, VCF ADJUSTMENTS	BOARD 3
SIGNALS DISTORT WHEN ALL THREE OSCILLATORS ARE USED TOGETHER	NO PROBLEM: VCF OVERDRIVEN	LOWER AUDIO INPUT SLIDERS TO ¾ UP	BOARD 3

SYMPTOM	PROBLEM	REPAIR	LOCATION
VCA LOCKED UP AT +15 VOLTS	4019 MODULE SHORTED INTERNALLY	REPLACE THE 4019 MODULE	BOARD 4
VCA CLIPS (DISTORTS) WHEN ADSR IS USED FULLY	NO PROBLEM: EXPONENTIAL INPUT SLIDER UP TOO FAR	LOWER RIGHT CONTROL SLIDER TO ¾ UP	BOARD 4 (PANEL)

6.2 Key Contact Adjustments for 3604P (3 Bus)

Note: See Section 9 for 3620 Adjustment Procedure.

6.2.1 CONTACT TIMING

Ideally, contacts should meet the bus exactly at the same time for the proper effect. The control voltage change should occur at the same time as the leading edge of the gate so that the pitch changes at the same time as the ADSR is initiated (which allows the

signal to be passed by the VCA or VCF). The trigger is delayed electronically 15 milliseconds to allow the noise on the leading part of the gate signal and the control voltage to subside. If the trigger is delayed much more than 15 milliseconds, the delay may become audible. If some keys do not give the proper response or do not trigger the ADSR at all, cleaning or adjustment may be needed.

6.2.2 TIMING CHECKOUT PROCEDURE

If any of the contacts fail to meet the bus rods at the proper time, the following effects may result:

EFFECT	CAUSE
Sound becomes audible before ADSR is initiated	Gate too soon or trigger too late
No sound at all: ADSR is not initiated	Gate too late or trigger too soon
Pitch changes before previous envelope has completed	Control Voltage too soon
Previous note is heard before correct note	Control Voltage too late

5.2 Types of Keyboards

The 2600 has been manufactured with two types of keyboards; the 3604P (single note) and the 3620 (two note).

5.2.1 3604P THREE BUS KEYBOARD

The earlier model 2600's used a model 3604P keyboard which has only single note capabilities. This means that one pitch (control voltage) is generated at a time. Each key has three contacts

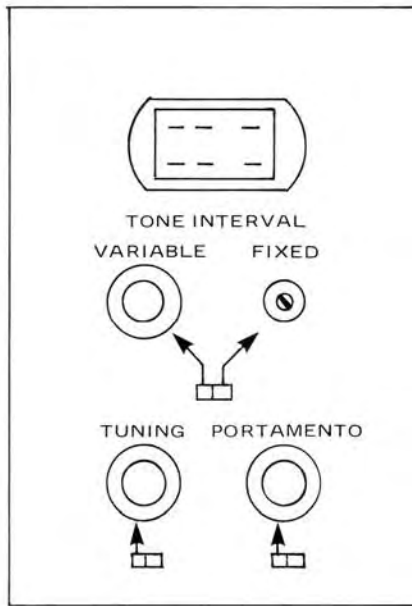

3604P Features: One memorized CV, Tuning Control, Portamento and Variable Interval.

which produce gate, trigger, and control voltage. The calibrations and adjustments are covered in Section 6.

5.2.2 3620 TWO BUS KEYBOARD

More recent 2600's are using the 3620 model keyboard. Technical data available in 3620 Service Manual.

See Section 6 for 3604P to 3620 conversion information.

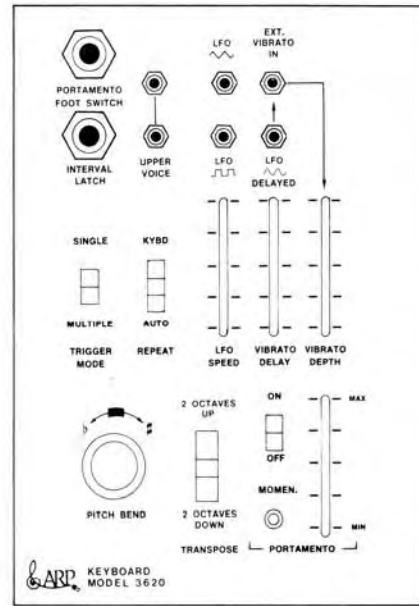

3620 Features: Two separate memorized Control Voltages, Interval Latch, Repeat Modes, LFO, Delayed Vibrato, Transpose, Pitch Bend.

SECTION 6 MISCELLANEOUS NOTES

6.1 Troubleshooting Hints

6.1.1 POINTS TO REMEMBER

Typically, most 2600 failures are mechanical problems. (pinched wires, broken slidepot, etc.)

Problems are likely to be 'D' jacks or internal connections via moxex connectors.

Beware of monitoring jack outputs to determine faults; often the problem is an input jack on another board.

6.1.2 SAMPLE FAILURES

No Module Output

affected externally.

1. Insure Power Supply (plus and minus) is getting to module.
2. Be sure that output of module is not being

3. Check for good connection at module pins.
4. Check for appropriate signal input at pins.
5. Check to see that all control voltages are present and correct at the module pins.

NOTE: When reassembling the unit, install the top of the panel first, then the bottom. Lay the unit on its back to reinstall the screws. (Be careful when putting in the panel screws that the 'T' nuts in the console are not crossthreaded.)

4.2 Opening the 3604 Keyboard

TURN THE UNIT OFF BEFORE DISCONNECTING THE KEYBOARD CONNECTING CABLE.

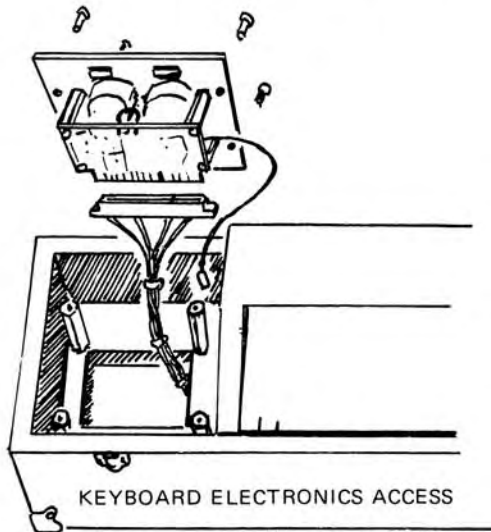

1. If repairs involve only the keyboard electronics, remove the grey metal panel. (see illustration) For proper operation of the keyboard, be sure that this panel does not become grounded since it is at the Keyboard Control Voltage potential.
2. If the keyboard contacts must be serviced, remove the four screws on the keyboard case and remove the entire assembly.

KEYBOARD CONTACTS ACCESS

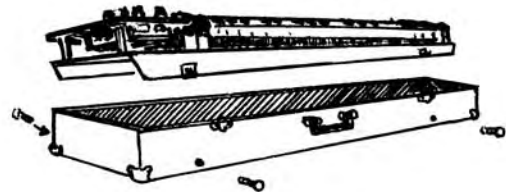

SECTION 5 REVISIONS/CHANGES

5.1 Types of Voltage Controlled Filter Modules: 4012, 4072

The later model 2601's use a 4072 filter module. This module is physically larger than the 4012 and is

not encapsulated. In order to use the newer style filter in an older unit, modifications are required to the control input as shown on the circuit below. The newer 4072 module is identical in operation to the 4012.

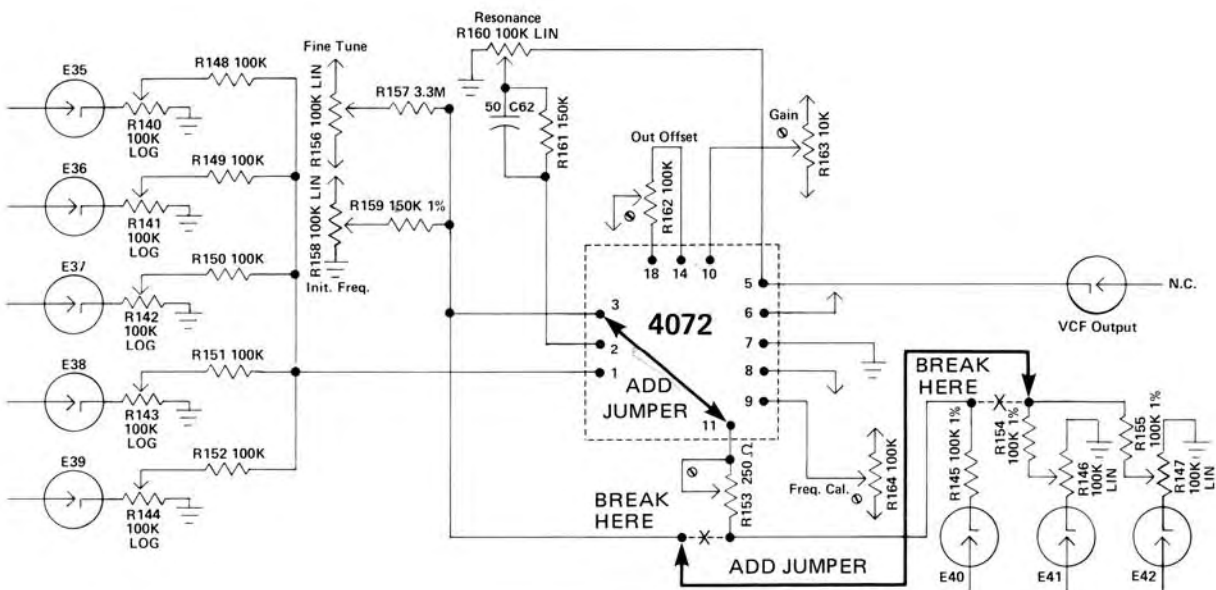

3.6.2 CONTROL REJECTION (VCA)

Ref. No.	Trimmer	Specifications/Trim Procedure
R193	Control Rejection	<ol style="list-style-type: none">1. Repeat steps 1-3 for Linear Gain Adjustment.2. Patch VCO 2 LF sine wave (@ 2Hz.) into VCA 'AR Control Input' jack.3. Close VCA 'VCF Audio Input' slider.4. Adjust R193 for minimum output offset.
R194	High Frequency Reject	NO ADJUSTMENT NECESSARY
R195	Exponential Gain	<ol style="list-style-type: none">1. Set R195 to full clockwise position.

3.7 Board 5-1 Adjustments - Sample and Hold

3.7.1 INTERNAL CLOCK not accessible to front panel

R385	Pulse Width	<ol style="list-style-type: none">1. Monitor Internal Clock output with an oscilloscope.2. Put S/H rate slider at maximum.3. Adjust R385 for 50% duty cycle.
------	-------------	--

SECTION 4 ASSEMBLY & DISASSEMBLY

4.1 Opening the 2600 Console

1. Remove the three screws on each side of the front panel.
2. Remove the four screws that hold the handle on top in place.

3. Using two dummy plugs in jacks as handles on the lower portion of the panel, lift the panel up and then out from the bottom. Take care not to damage any of the components as you lift the panel out.
4. Lay the panel on something soft such as foam rubber or a blanket to prevent damage to the panel.

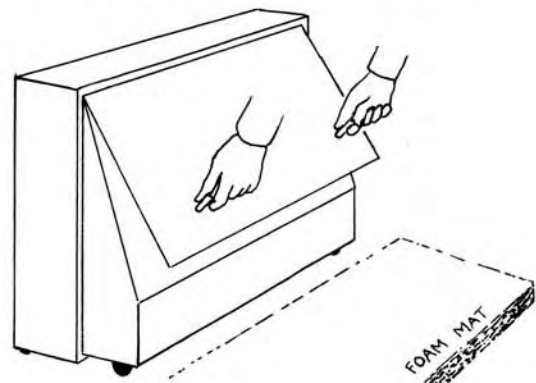
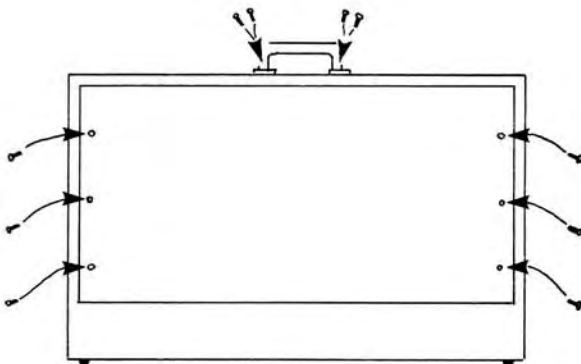

3.5.2 VOLTS PER OCTAVE (VCF)

Ref. No.	Trimmer	Specifications/Trim Procedure
R153	1V/OCT	<ol style="list-style-type: none">1. Repeat steps 1-5 for frequency calibrate (disconnect dummy plug).2. Connect keyboard to console and depress low C (0 volts).3. Adjust initial frequency slider and fine tune slider for 200Hz.4. Depress C three octaves higher and adjust R153 for 1600Hz. (3 volts).5. Repeat steps 2-4 until low C remains at 200Hz. and C3 remains at 1600Hz.

3.5.3 OUTPUT OFFSET

R162	Output Offset	<ol style="list-style-type: none">1. Monitor VCF output with an oscilloscope.2. Initial frequency, fine tune, and resonance slider - left.3. All input sliders - down.4. Adjust R162 for minimum d.c. output. Movement of the initial frequency slider should not cause more than 1 volt deflection.
------	---------------	---

3.5.4 GAIN ADJUST

R163	Gain	<ol style="list-style-type: none">1. Open VCF initial frequency slider - left.2. Resonance slider - minimum.3. Raise VCO 1 square wave input slider into filter and adjust R163 for same amplitude as measured at VCO 1 output.
------	------	---

NOTE: You are adjusting for Unity Gain.

3.6 Board 4 Adjustment - Voltage Controlled Amplifier

3.6.1 LINEAR GAIN

R196	Linear Gain	<ol style="list-style-type: none">1. Monitor VCA output with an oscilloscope.2. Patch VCO 3 sawtooth to VCA 'VCF Audio Input' jack and raise audio input slider fully.3. Put the initial gain slider fully left (minimum).4. Raise VCA AR control slider all the way.5. Depress and hold the manual start button and adjust R196 for 10V P.P. maximum signal output.
------	-------------	--



MODEL 2600
ASSEMBLY
BOARD 1

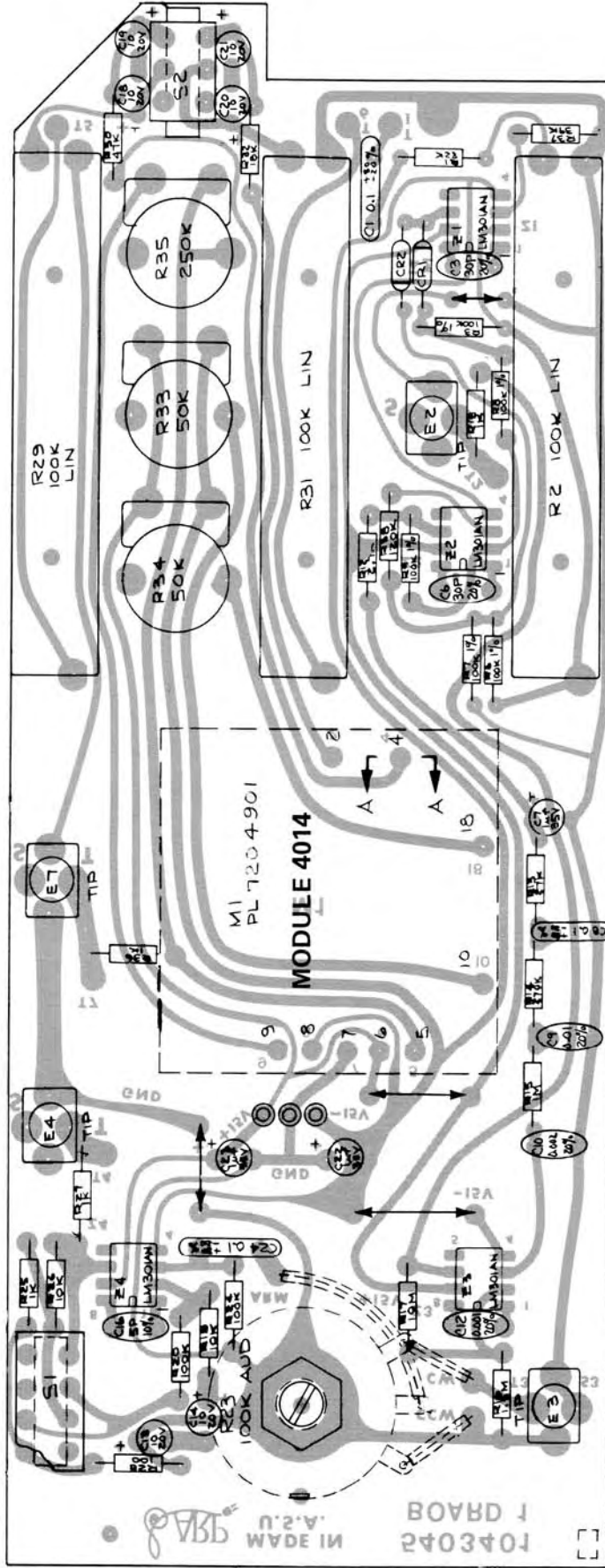

BOARD 3
REV. 3
U.S.A. MADE IN
ARP

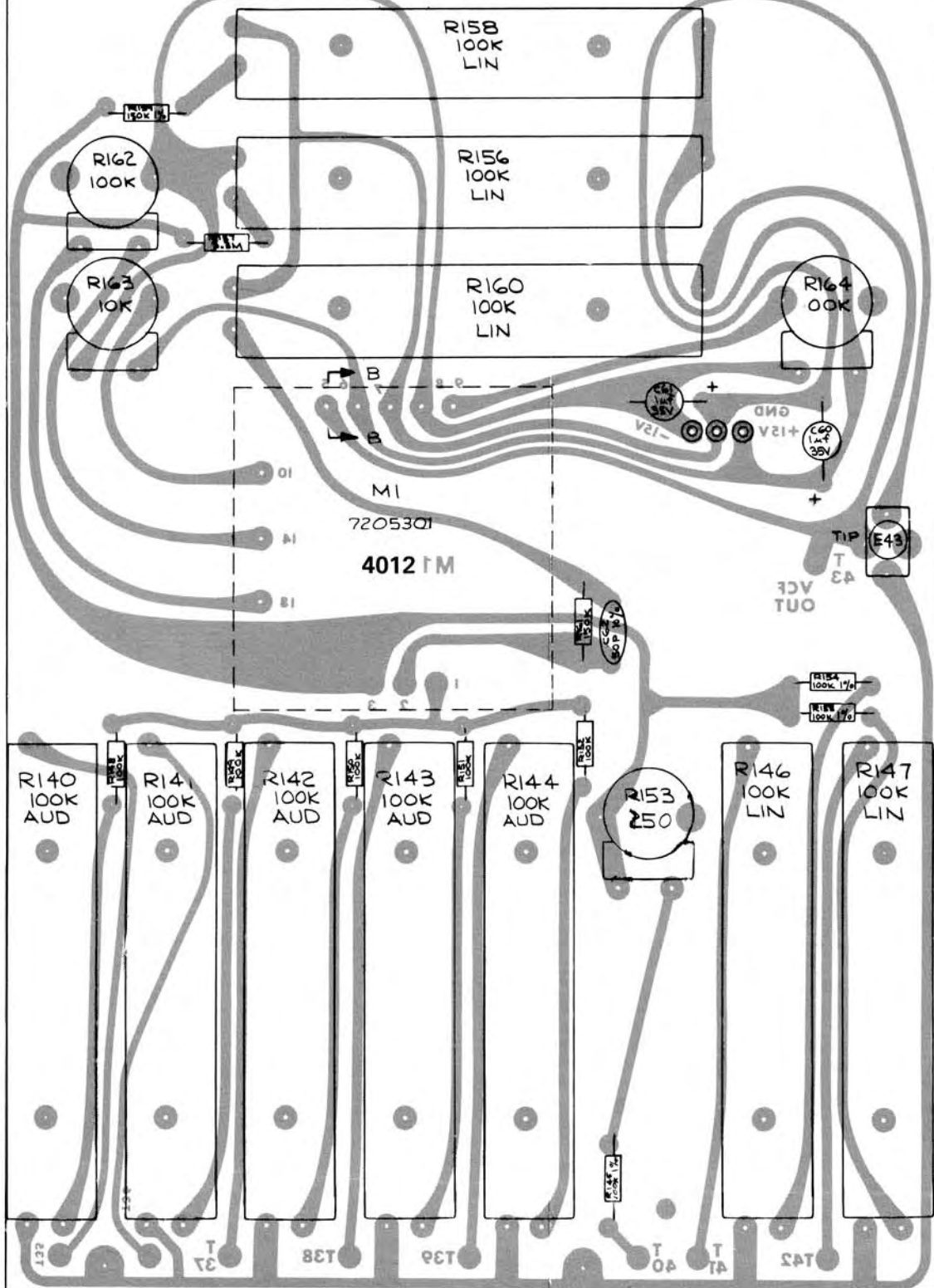

MODEL 2600
ASSEMBLY
BOARD 3

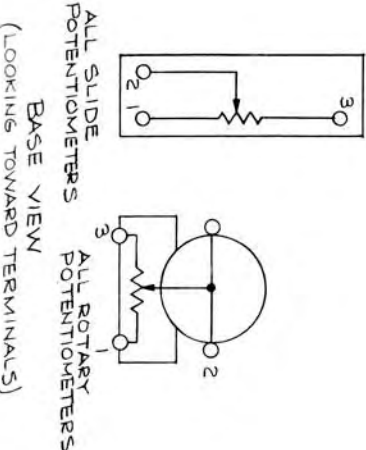
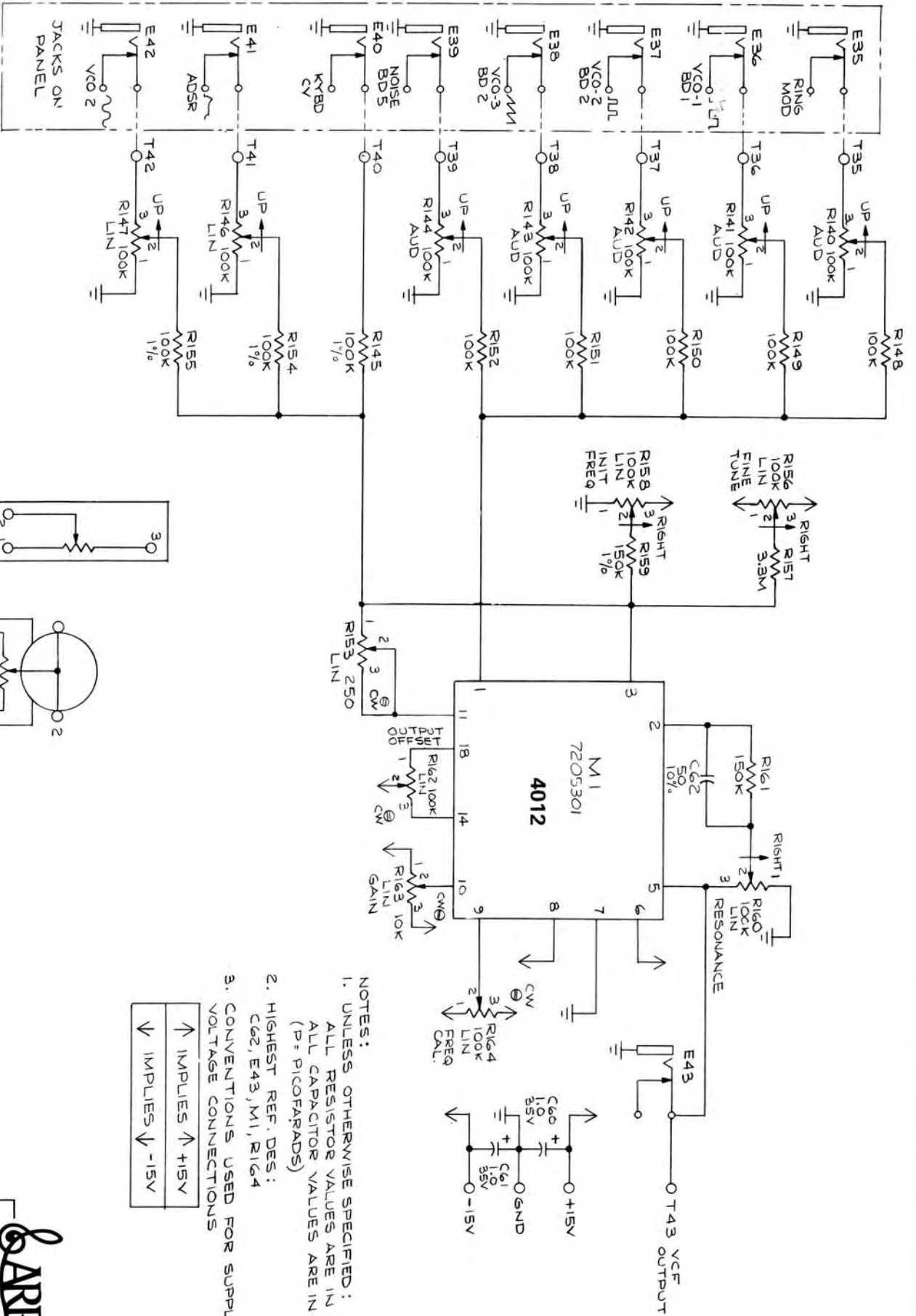

- NOTES:
1. UNLESS OTHERWISE SPECIFIED: ALL RESISTOR VALUES ARE IN OHMS ALL CAPACITOR VALUES ARE IN μ f (P = PICOFARADS)
 2. HIGHEST REF. DES: C62, E43, M1, R164
 3. CONVENTIONS USED FOR SUPPLY VOLTAGE CONNECTIONS

↑	IMPLIES +15V
↓	IMPLIES -15V

ARP
 MODEL 2600
 SCHEMATIC
 BOARD 3

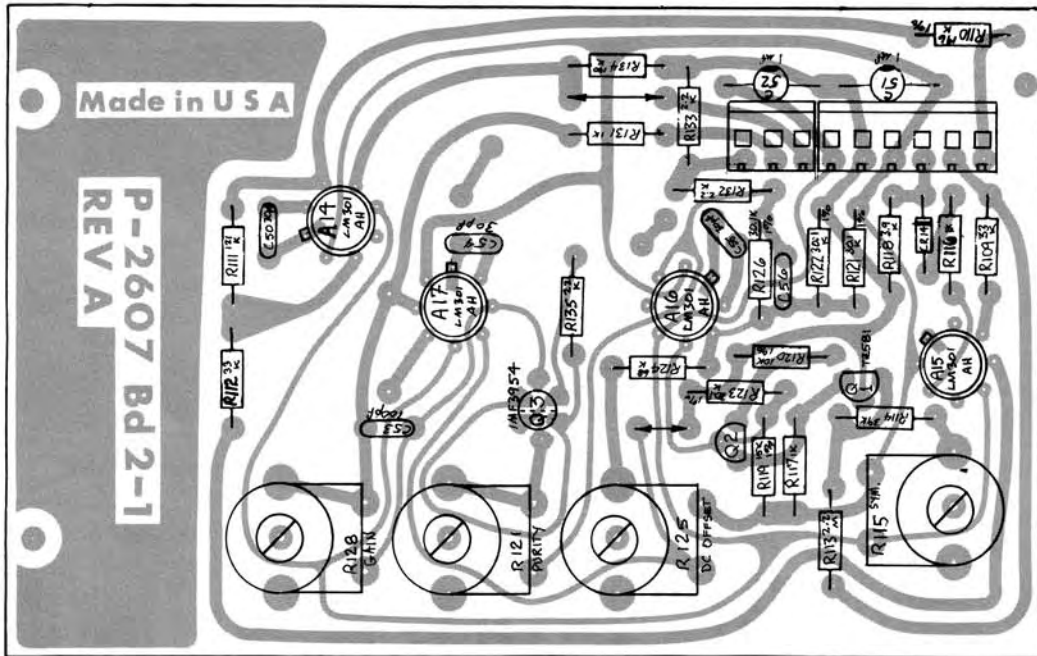

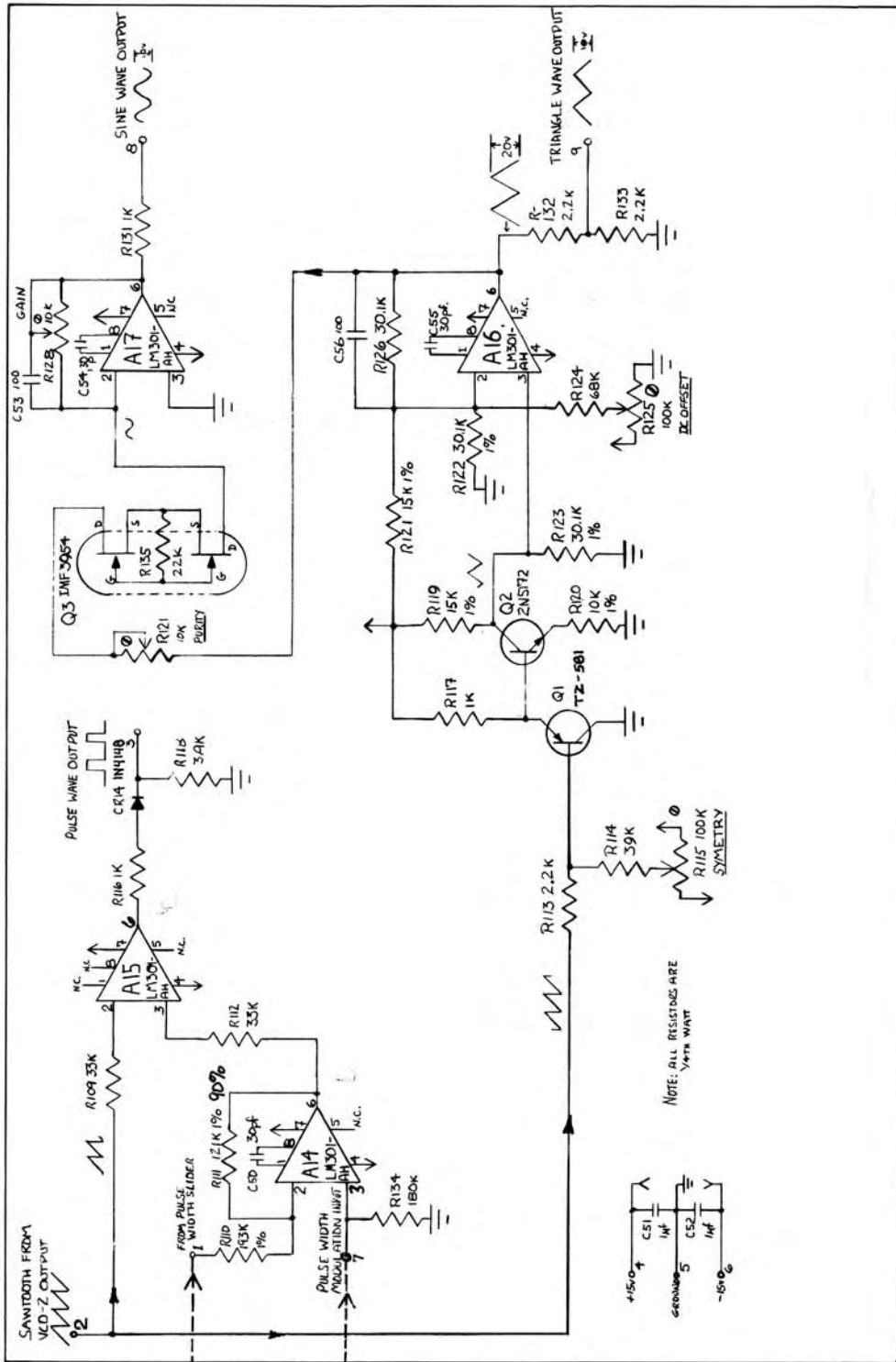

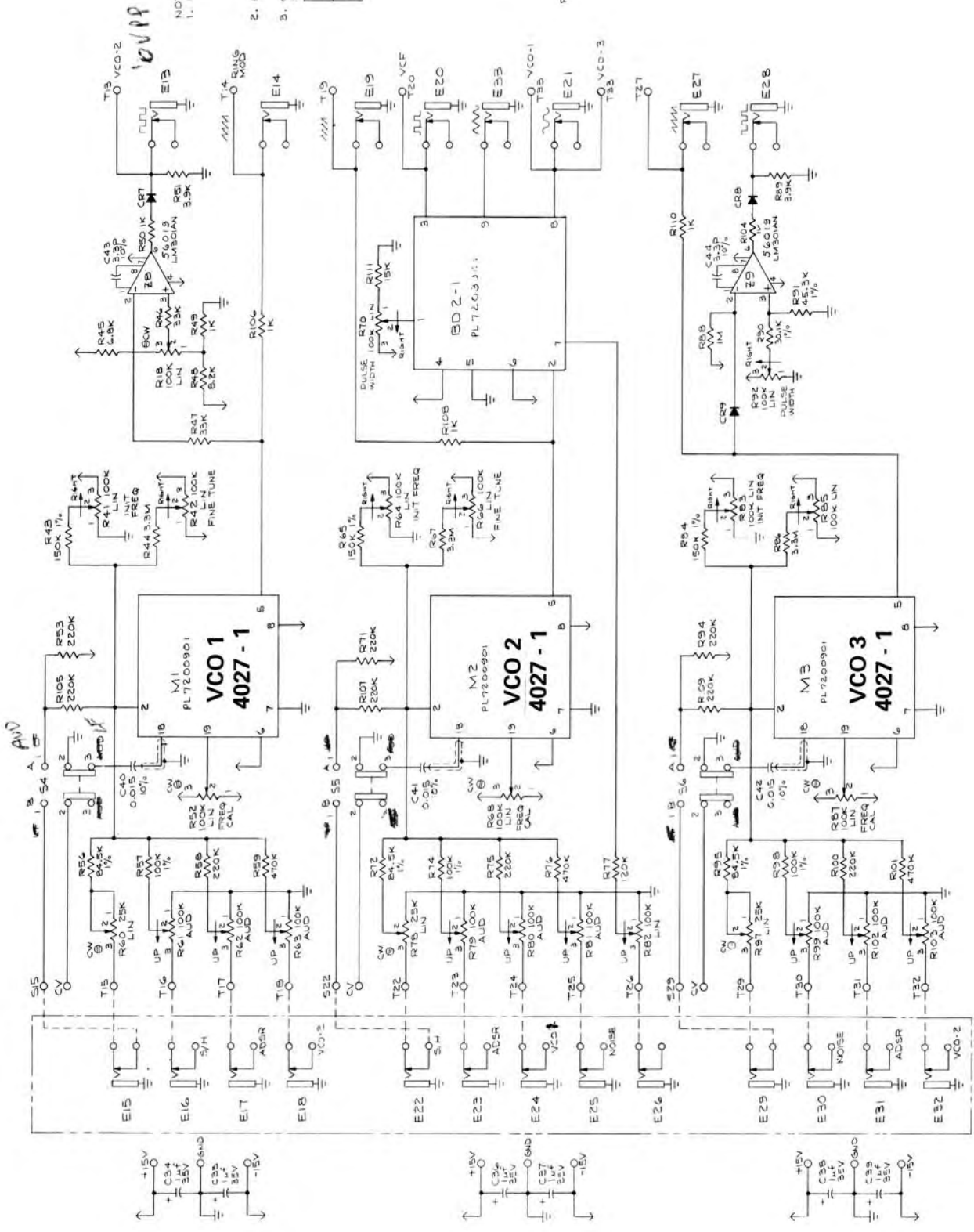

- NOTES:
1. UNLESS OTHERWISE SPECIFIED: ALL RESISTOR VALUES ARE IN OHMS ALL CAPACITOR VALUES ARE IN pF (p = PICO FARADS) ALL DIODES ARE 1N414B
 2. HIGHEST REF DES: C44, CR9, E33, M3, R111, S6, Z9
 3. CONVENTIONS USED FOR SUPPLY VOLTAGE CONNECTIONS

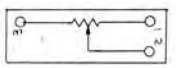
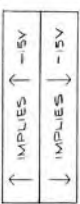

ALL SLIDE POTENTIOMETERS
ALL ROTARY POTENTIOMETERS
BASE VIEW
(LOOKING TOWARD TERMINALS)

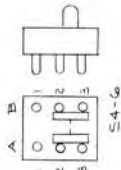

ARP
MODEL 2600
SCHEMATIC
BOARD 2

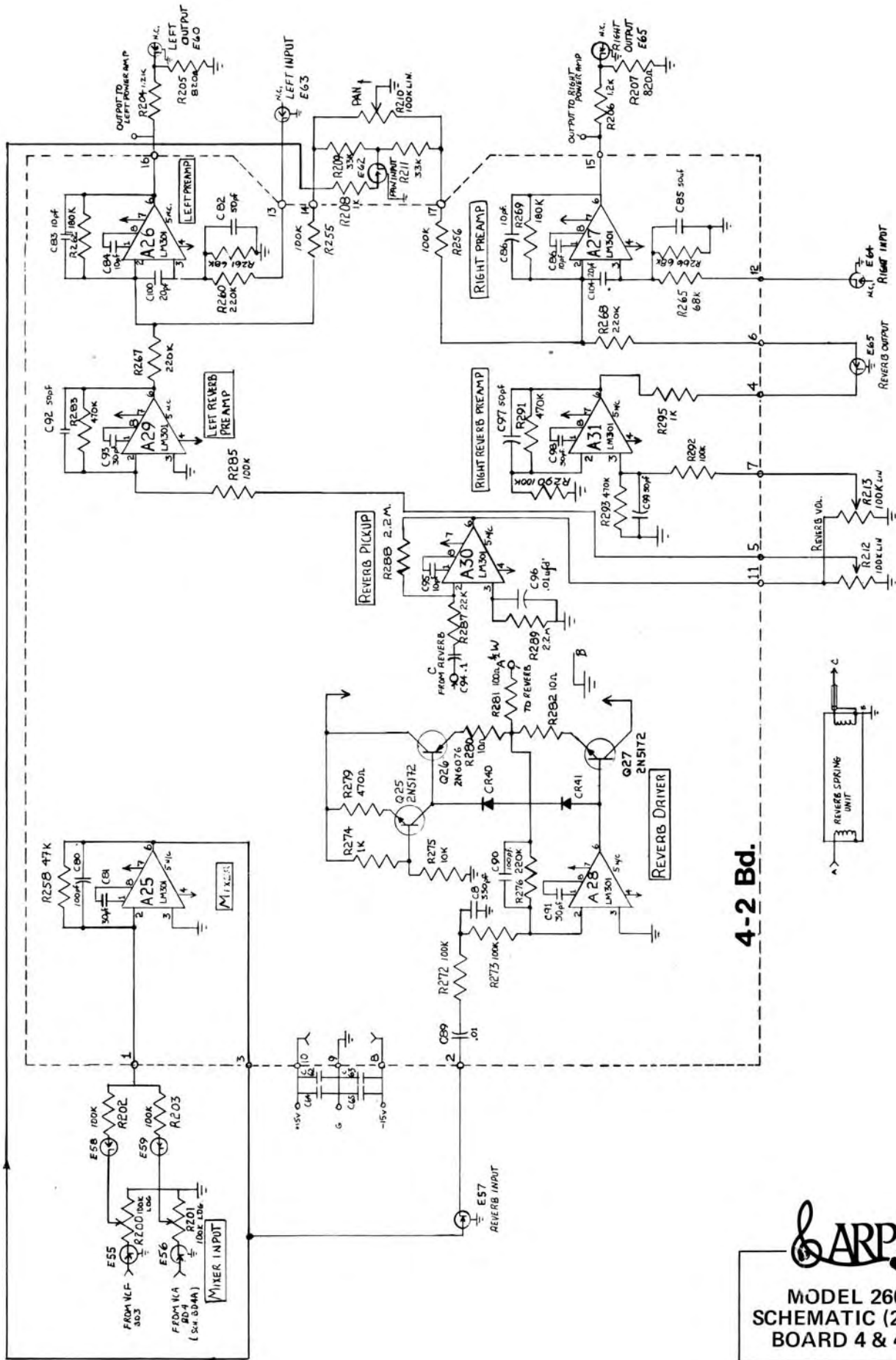

4-2 Bd.



MODEL 260
SCHEMATIC (2 of 2)
BOARD 4 & 4-2

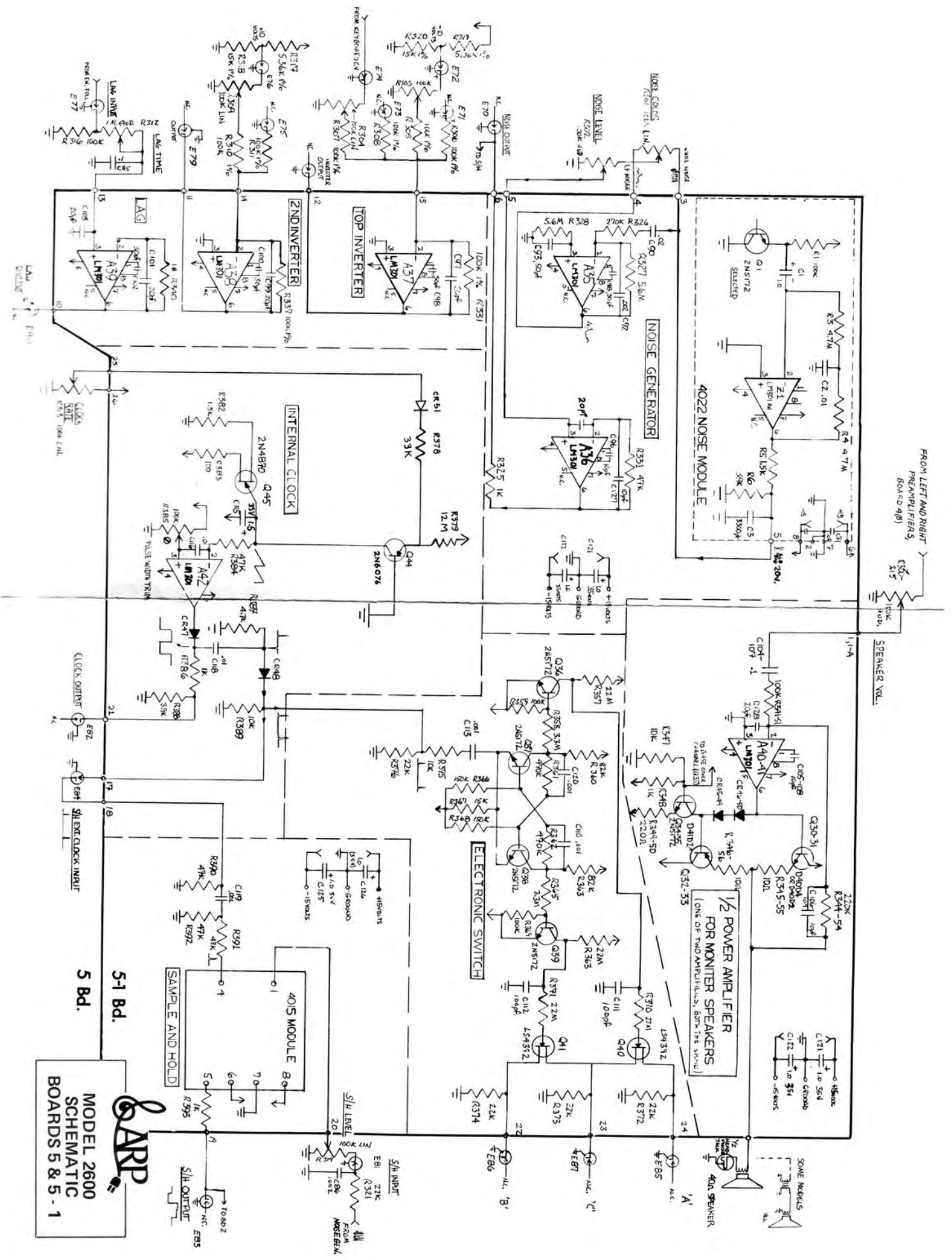

MODEL 2600
SCHEMATIC
BOARDS 5 & 5-1



5-1 Bd.

5 Bd.

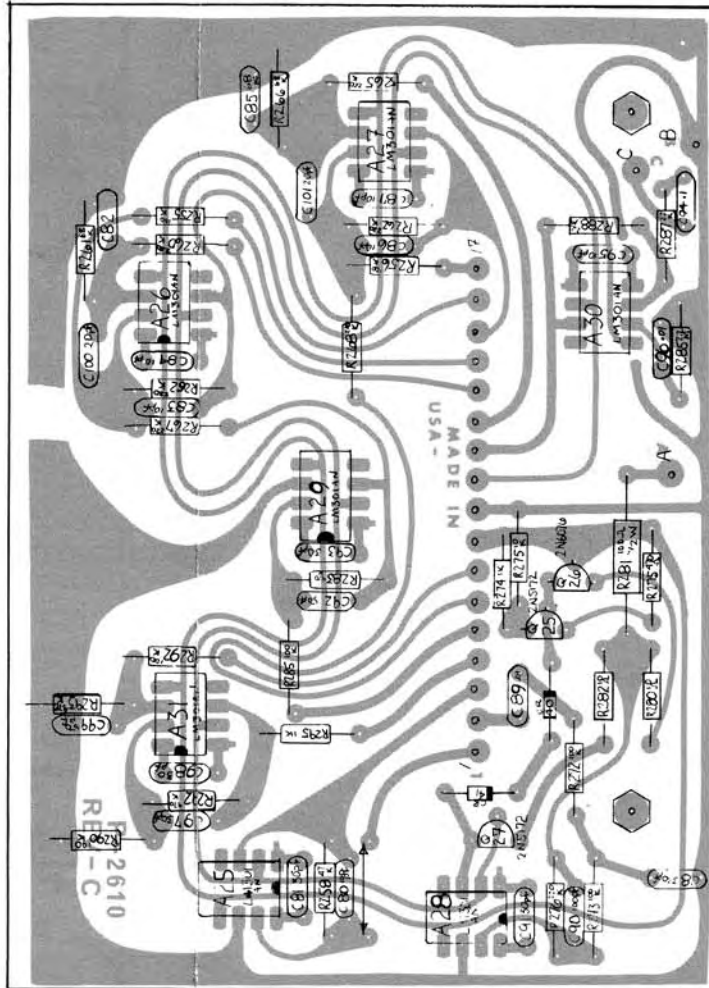

MODEL 2600
ASSEMBLY
BOARD 4 - 2

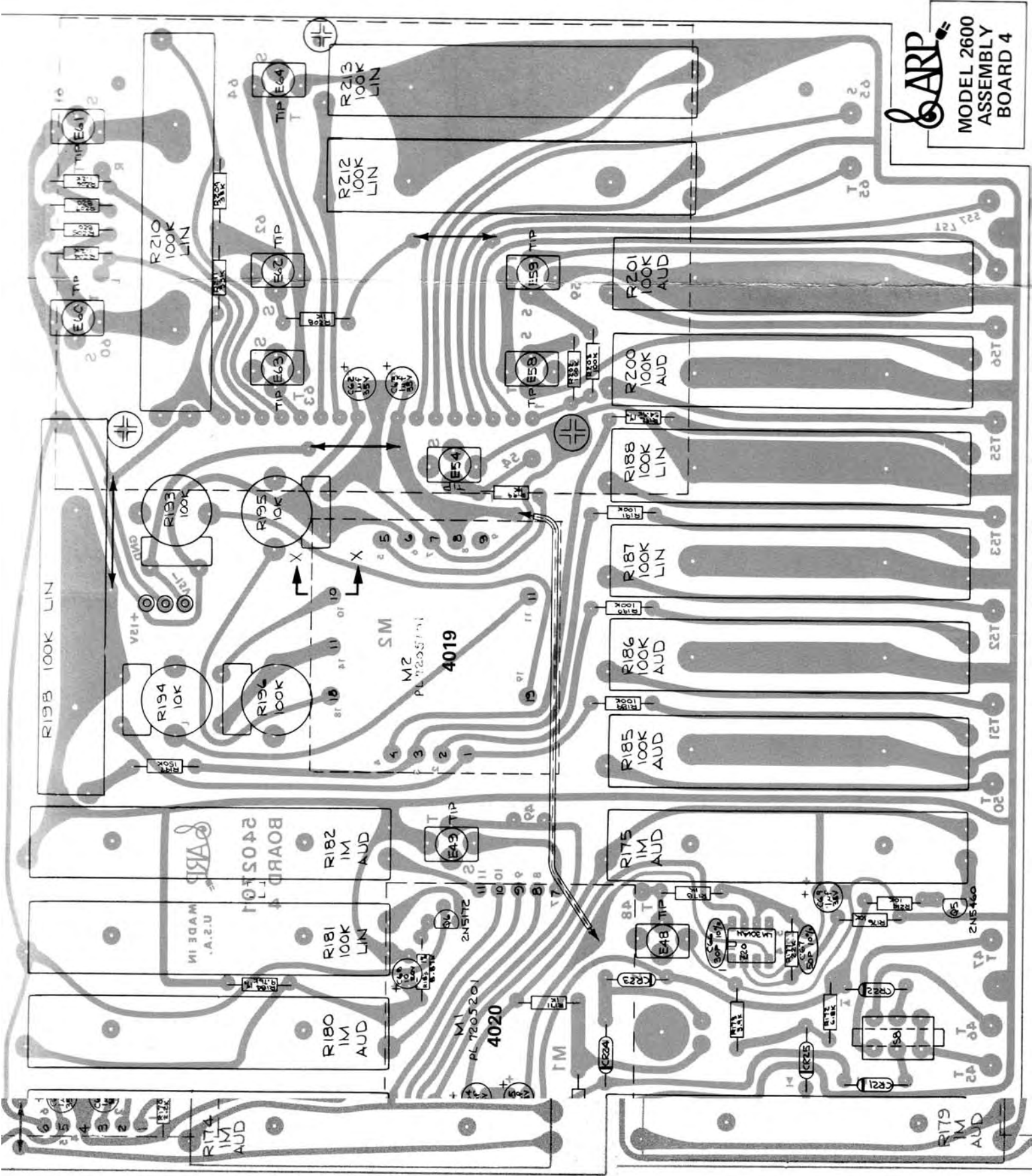

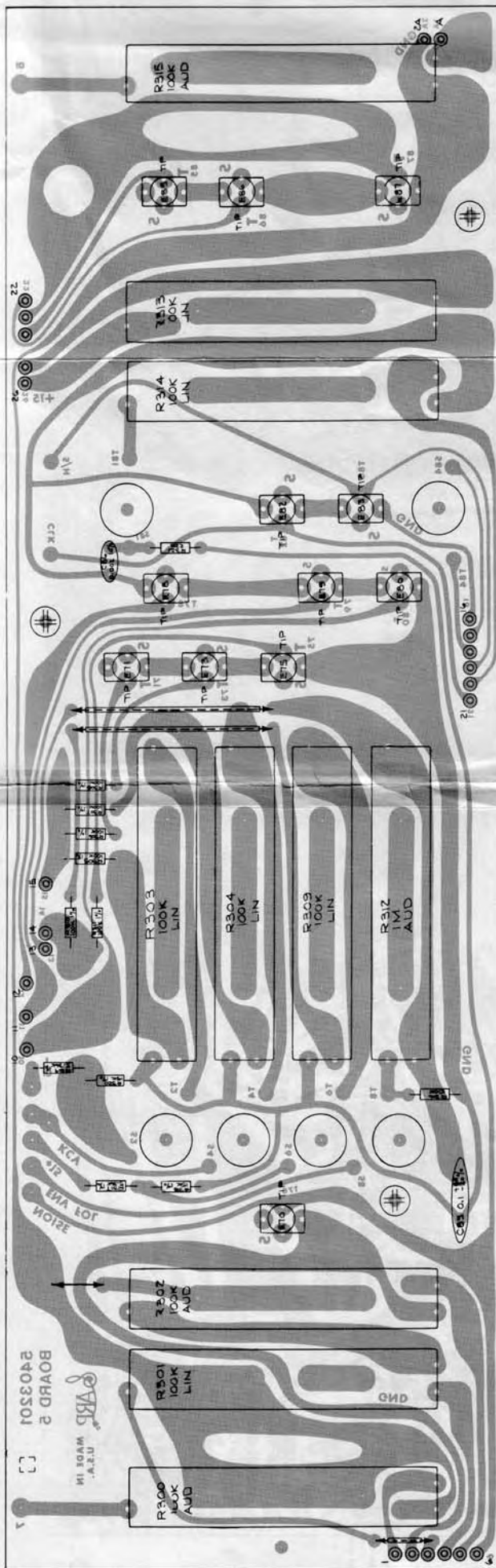



 MODEL 2600
 ASSEMBLY
 BOARD 5

BOARD 2
 2403501

 MADE IN U.S.A.

 MODEL 2600
 ASSEMBLY
 BOARD 5 - 1

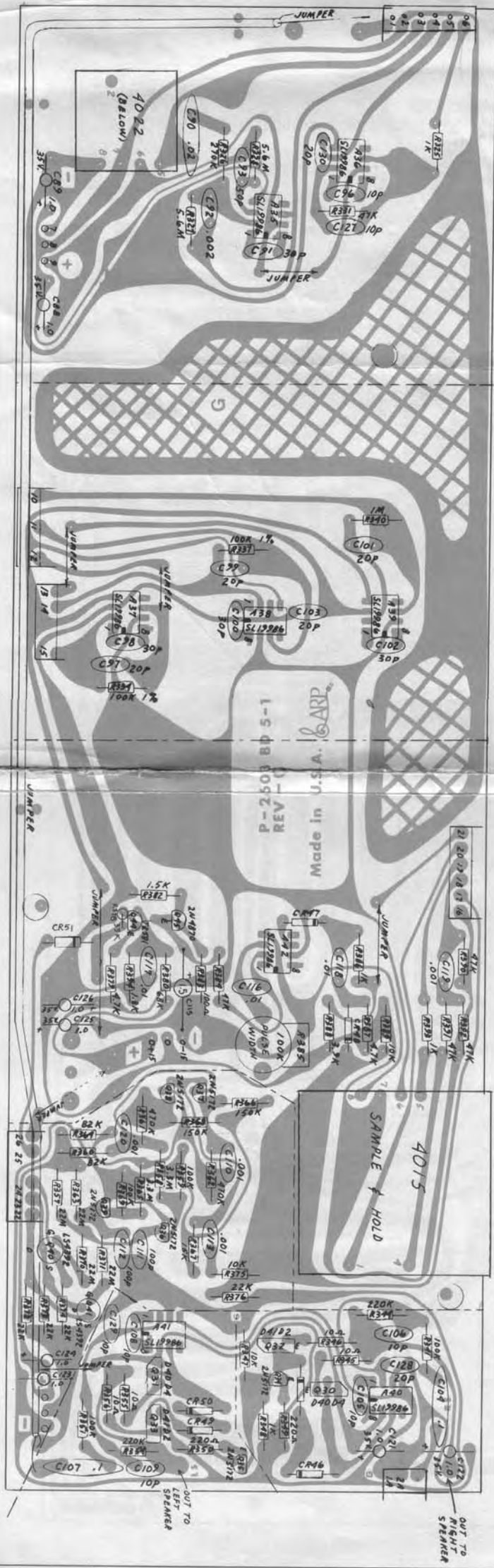

A11	1401401	748DC	IC OP AMP
Q1, 3	1301201	2N4248	TSTR PNP
Q2	1301701	2N5172	TSTR NPN
BR1	1201001	MD920A	BRIDGE RECTIFIER
Q4	1304501	MJE1100	TSTR NPN POWER
Q5	1304301	MJE1090	TSTR PNP POWER
C6, 7	1100612	G-0-010-G-20-0	CAP 10uf 35V TANT
C1, 2	1101301	TCW102V050N1R3P	CAP 1000uf 50V DC

3604P Keyboard

REFERENCE	ARP PART NUMBER	ARP/MFG NUMBER	DESCRIPTION
A1	7205501	8007	HIGH Z OP AMP MODULE
C2	1100311	-----	CAP .15uf POLY CARB
C4, 5	1100609	G-0-001-G-20-0	CAP 1uf 35V
C6	1100317	-----	CAP .1uf 50V
C7	1100315	-----	CAP .47uf 50V
CR1	1200301	1N4148	DIODE
Q2, 3, 5	1301701	2N5172	TSTR NPN
Q1	1302801	2N6076	TSTR PNP
Q4, 6	1304701	TZ581	TSTR PNP
VARIABLE INTERVAL	1000806	JAIN56S103UA	ROT POT 10K
FIXED INTERVAL	1000803	JAIN40S252UC	ROT POT 2.5K
PORTAMENTO	1000813	JAIN56S504UA	ROT POT 500K
TUNING	1000801	JAIN56S102UA	ROT POT 1K

3620 Keyboard See Section 9

Miscellaneous

	ARP PART NUMBER	ARP/MFG NUMBER	DESCRIPTION
	2400801		PREAMP KNOB
	-----		SHUKE HANDLE
	2300405	6-32 x 1¼	SCREW (HANDLE)
	2307301	6-32 x ¼	ACORN NUT
	2401001	X49	SLIDE POT KNOBS
	1901701		POWER SWITCH
	1800101		POWER LIGHT
	2100601		POWER PLUG SOCKET
	2201501		POWER CORD
	-----		KYBD CONN CABLE (3604P)
	2100901		CONSOLE KYBD JACK
	2305902		NO. 6 FIBRE WASHER
	2101101		STEREO JACK
	2307602		SHEET METAL SCREW HOLDER
	2600601		SPEAKER (40ohm)
	2600701		REVERB TANK

PARTS ORDERING

Telephone: 617/861-6000, Service Department

Replacement parts can be ordered in writing or by

phone. Contact the ARP Service Department and use the ARP part number when ordering. *A five dollar minimum is required unless the order is received with cash in advance. No collect calls will be accepted.*

R153	1000903	U201R251B	TRIMPOT 250ohm LIN
R140-144	1001202	WH3260	SLIDE POT 100K AUD
R146, 147	1001201	WH3259	SLIDE POT 100K LIN
C60, 61	1100609	G-0-001-G-20-0	CAP 1uf 35V

Board 4

REFERENCE	ARP PART NUMBER	ARP/MFG NUMBER	DESCRIPTION
VCA 4019	7205101	-----	VCA
ADSR 4020	7205201	-----	ADSR
Z20	1400801	LM301AN	IC OP AMP
Q5	1302401	2N5460	TSTR P CHAN
Q6	1301701	2N5172	TSTR NPN GP
S9	1900401	30-1	SPST (MANUAL START)
S8	1901501	GF-126	SWITCH DPDT
E45-47, 50-53, 55-57	2101601	42A	TINI 'D' JACK
E58, 59, 48, 49, 54, 60, 61, 62, 63, 64, 65	2101201	142A	TINI 'D' JACK (CASE)
R194, 195	1000909	U201R103B	TRIMPOT 10K LIN
R193, 196	1000915	U201R104B	TRIMPOT 100K LIN
(Ref. to pg. 34)	1001201	WH3259	SLIDE POT 100K LIN
(Ref. to pg. 34)	1001202	WH3260	SLIDE POT 100K AUD
(Ref. to pg. 34)	1001203	WH3261	SLIDE POT 1M AUD
C62, 63, 64, 65	1000609	G-0-001-G-20-0	CAP 1uf 35V
CR21-25	1200301	1N4148	DIODE

Board 5

REFERENCE	ARP PART NUMBER	ARP/MFG NUMBER	DESCRIPTION
E72, 76, 74, 77, 81, 84	2101601	42A	TINI 'D' JACK
E70, 71, 73, 75, 78, 79, 80, 82, 83, 85, 86, 87	2101201	142A	TINI 'D' JACK (CASE)
(Ref. to pg. 34)	1001201	WH3259	SLIDE POT 100K LIN
(Ref. to pg. 34)	1001202	WH3260	SLIDE POT 100K AUD
(Ref. to pg. 34)	1001203	WH3261	SLIDE POT 1M AUD

Board 5-1

REFERENCE	ARP PART NUMBER	ARP/MFG NUMBER	DESCRIPTION
C45-50	1200301	1N4148	DIODE
A35-41	1400801	LM301AN	IC OP AMP
Q44	1302801	2N6076	TSTR PNP
Q45	1301601	2N4870	TSTR UNI-JUNCTION
Q36-39	1301701	2N5172	TSTR NPN
Q40, 41	1301301	2N4392	TSTR N CHAN
4015	7205001	-----	SAMPLE & HOLD MODULE
4022	7204801	-----	NOISE MODULE
C121, 122	1100609	G-0-001-G-20-0	CAP 1uf ELECT

Power Supply

REFERENCE	ARP PART NUMBER	ARP/MFG NUMBER	DESCRIPTION
A1	1401301	723DC	VOLTAGE REGULATOR

SECTION 7 PARTS LIST

Board 1

REFERENCE	ARP PART NUMBER	ARP/MFG NUMBER	DESCRIPTION
Z1, 2, 3, 4	1400801	LM301AN	IC OP AMP
M1 (4014)	7204901	-----	RING MODULATOR
CR1, 2	1200301	1N4148	DIODE
S1	1901601	G-128-L	SWITCH, DP3T
R23	1000811	JAIN200P104AA	100K AUD ROT POT
R2, 29, 31	1001201	WH3259	SLIDE POT 100K LIN
E1, 5, 6	2101601	42A	TINI 'D' JACK
E2, 3, 4, 7	2101201	142A	TINI 'D' JACK (CASE)
R33, 34	1000913	U201R503B	TRIMPOT 50K LIN
R35	1000917	U201R254B	TRIMPOT 250K LIN
C7, 22, 23	1100609	G-0-001-G-20-0	CAP 1uf 35V
C13, 14, 18, 19, 20, 21	1100605	G-0-010-G-20-0	CAP 10uf 25V

Board 2

REFERENCE	ARP PART NUMBER	ARP/MFG NUMBER	DESCRIPTION
M1, 2, 3, (4027-1)	7200901	-----	VCO
(Ref. to pg. 34)	1001201	WH3259	SLIDE POT 100K LIN
(Ref. to pg. 34)	1001202	WH3260	SLIDE POT 100K AUD
R18, 52, 68, 87	1000915	U201R104B	TRIMPOT 100K LIN
R60, 78, 97	1000911	U201R253B	TRIMPOT 25K LIN
S4, 5, 6	1901501	GF-126	SWITCH DPDT
E15-18, 22-26, 29-32	2101601	42A	TINI 'D' JACK
E13, 14, 19, 20, 21, 27, 28	2101201	142A	TINI 'D' JACK (CASE)
Z8, 9	1400801	LM301AN	IC OP AMP
C34-39	1100609	G-0-001-G-20-0	CAP 1uf 35V
CR7-9	1200301	1N4148	DIODE

Board 2-1

REFERENCE	ARP PART NUMBER	ARP/MFG NUMBER	DESCRIPTION
A14, 15, 16, 17	1400701	LM301AH	IC OP AMP
Q1	1304701	TZ581	TSTR PNP
Q2	1301701	2N5172	TSTR NPN
Q3	1303901	IMF3958	TSTR N CHAN
CR14	1200301	1N4148	DIODE
R115, 125	1000915	U201R104B	TRIMPOT 100K LIN
R121, 128	1000909	U201R103B	TRIMPOT 10K LIN

Board 3

REFERENCE	ARP PART NUMBER	ARP/MFG NUMBER	DESCRIPTION
M1 (4012)	7205301	-----	VCF
M1 (4072)	7213301	-----	VCF
E35-42	2101601	42A	TINI 'D' JACK
E43	2101201	142A	TINI 'D' JACK (CASE)
R163	1000909	U201R103B	TRIMPOT 10K LIN
R162, 164	1000915	U201R104B	TRIMPOT 100K LIN

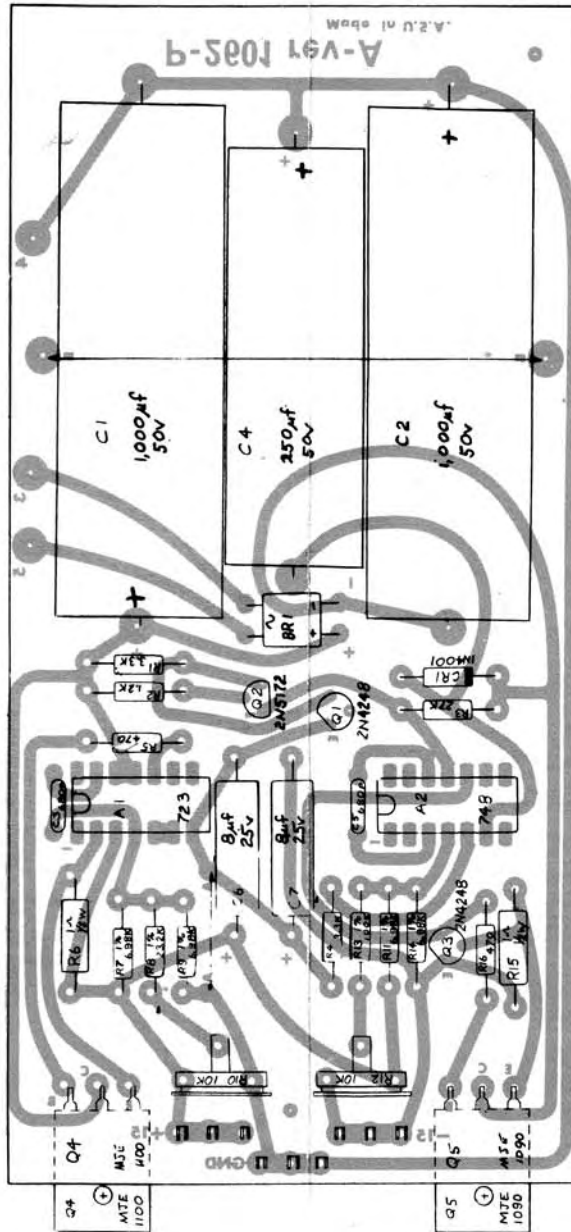

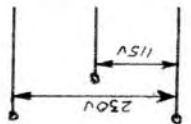
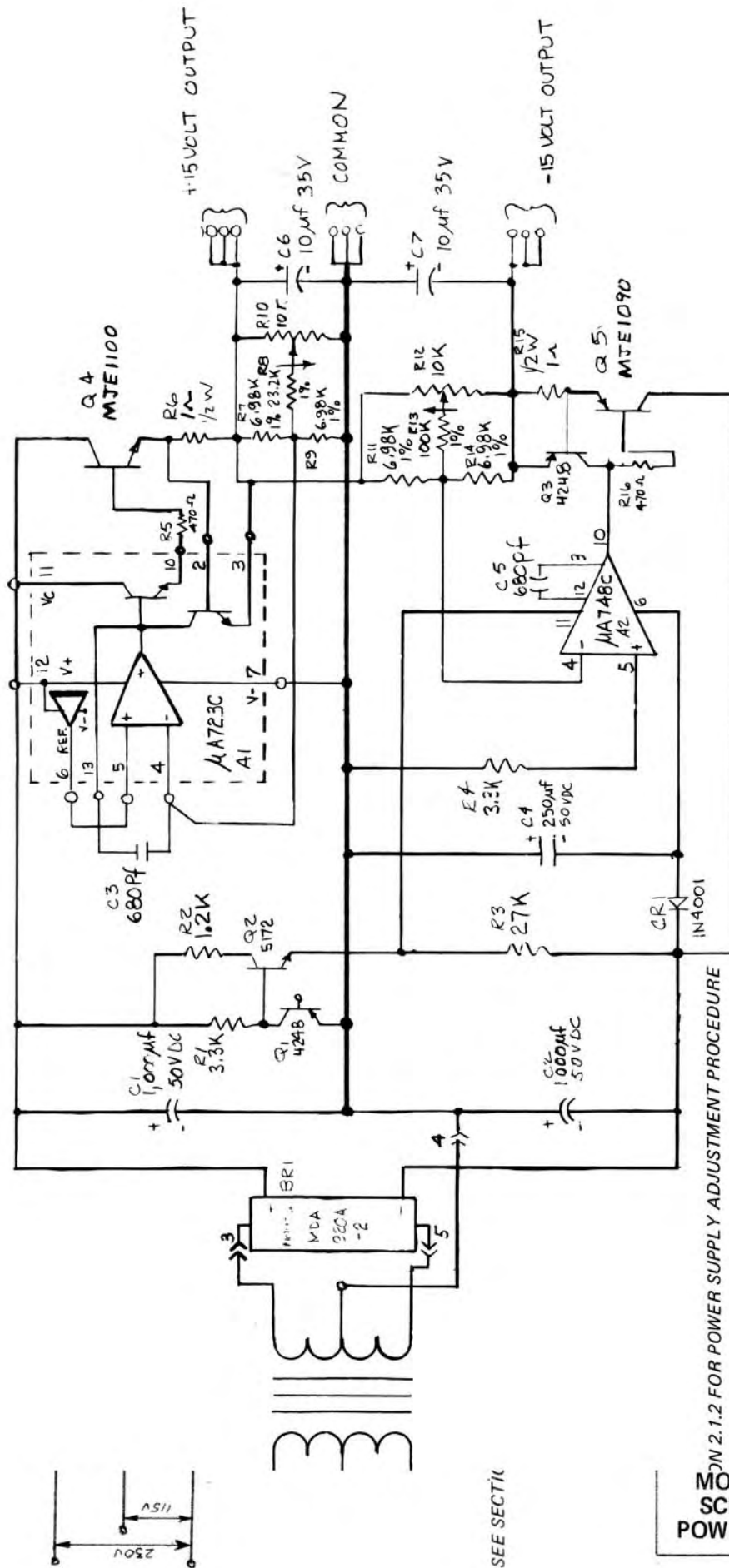

**MODEL 2600
 ASSEMBLY
 POWER SUPPLY**



SEE SECTIC

SECTION 2.1.2 FOR POWER SUPPLY ADJUSTMENT PROCEDURE
**MODEL 2600
 SCHEMATIC
 POWER SUPPLY**

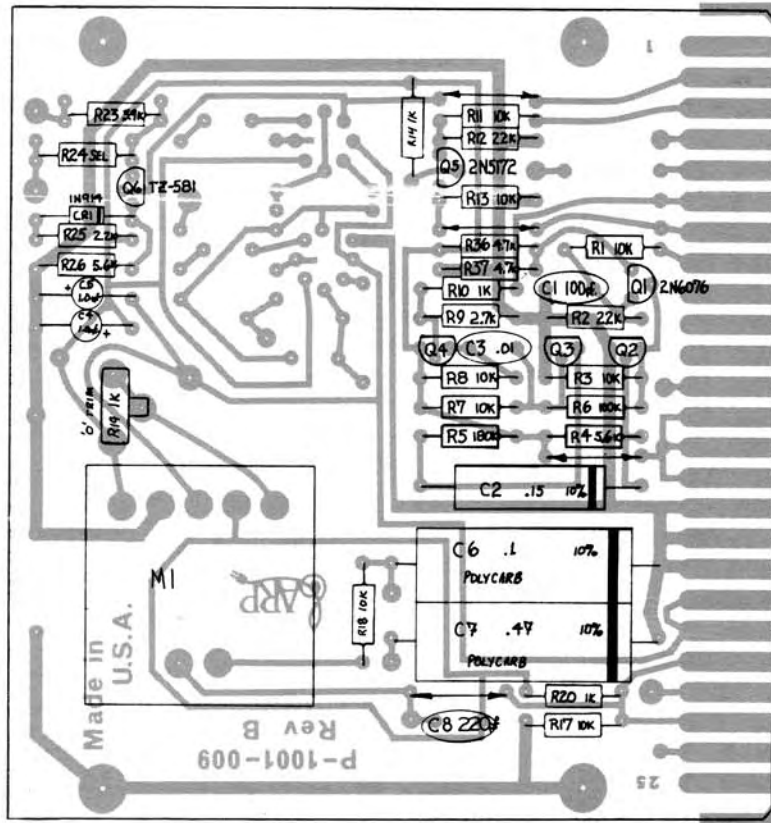



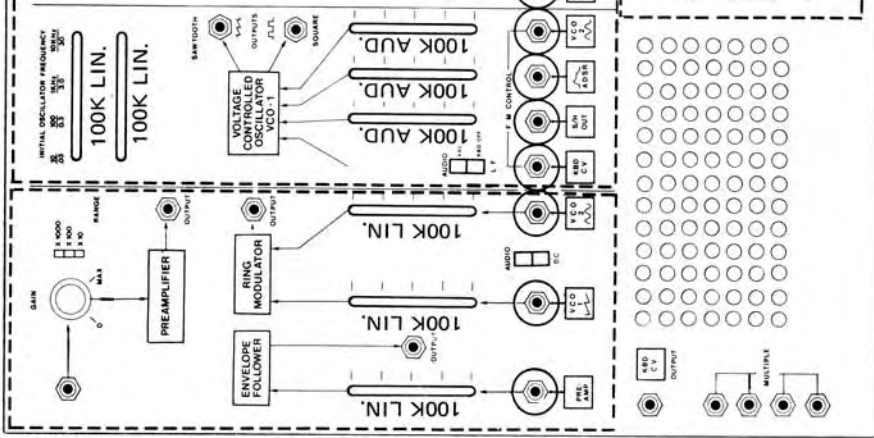

 MODEL 2600
 ASSEMBLY
 3604P KEYBOARD

BOARD 1

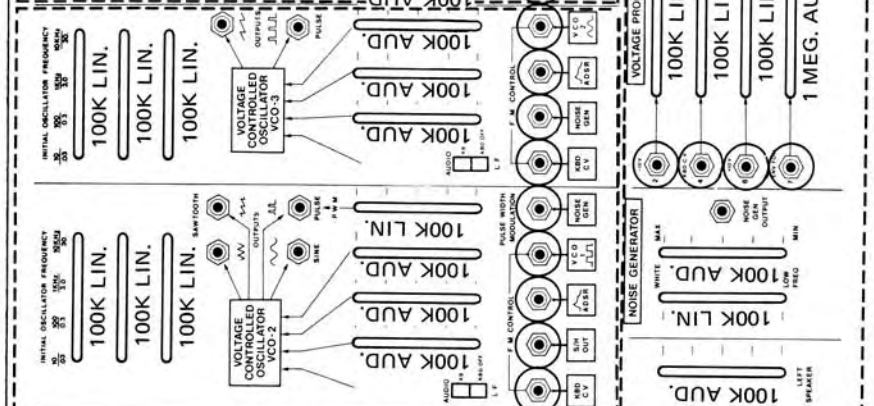

BOARD 2



BOARD 3

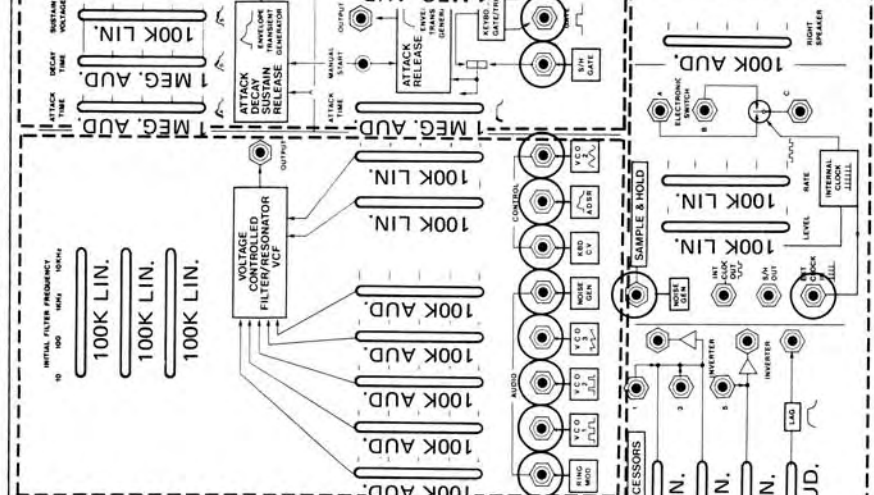

BOARD 4

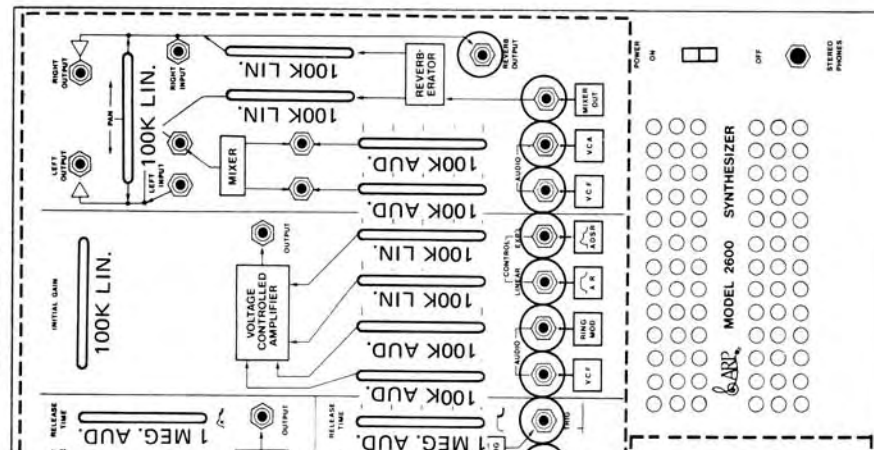

BOARD 5

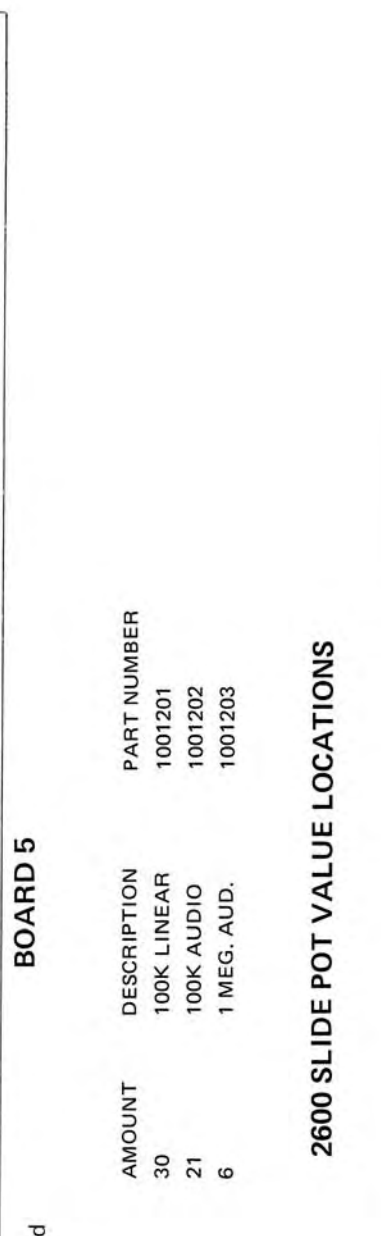

○ = new style jack which need not be unscrewed to remove P.C. board.

AMOUNT	DESCRIPTION	PART NUMBER
30	100K LINEAR	1001201
21	100K AUDIO	1001202
6	1 MEG. AUD.	1001203

2600 SLIDE POT VALUE LOCATIONS





SERVICE NOTES

MODEL: 2600

DATE: 10-31-74

SUBJECT: NOTICE OF PRODUCTION CHANGE

PAGE 1 of 2

After October 1 1974, all normalizing jacks in the 2600 have been replaced with a panel mounted jack. Jumper wires connect the new jack to the printed circuit board.
(See page 2 for the locations of the affected jacks.)

Use part number 42A when ordering the new type jack.

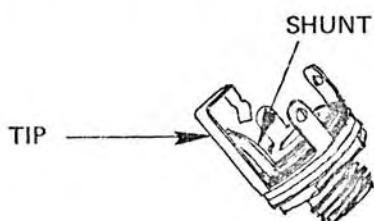
**NOTE:**

- 1) Care should be taken not to bend the tip of the jack when mounting replacement jacks to the front panel.
- 2) When removing the printed circuit boards for servicing, take care not to break the jumper wires connecting the jacks to the PC board.
- 3) Be sure to remove the two screws holding the printed circuit board in place near the bottom of the board when servicing the electronics.



SN-0 12

SERVICE NOTES

MODEL: 2600

DATE: 11-1-74

SUBJECT: REVERB WIRES

PROBLEM: The wires in the reverb unit break causing the reverb to be dead.

CAUSE: The wires connecting the input and output jack to the reverb pickup and driver are flexed by the movement of the spring mounted reverb assembly.

SOLUTION: Apply RTV silicone rubber to the wires on the input and output jacks and the reverb driver and pickup coils to prevent the wires from flexing.

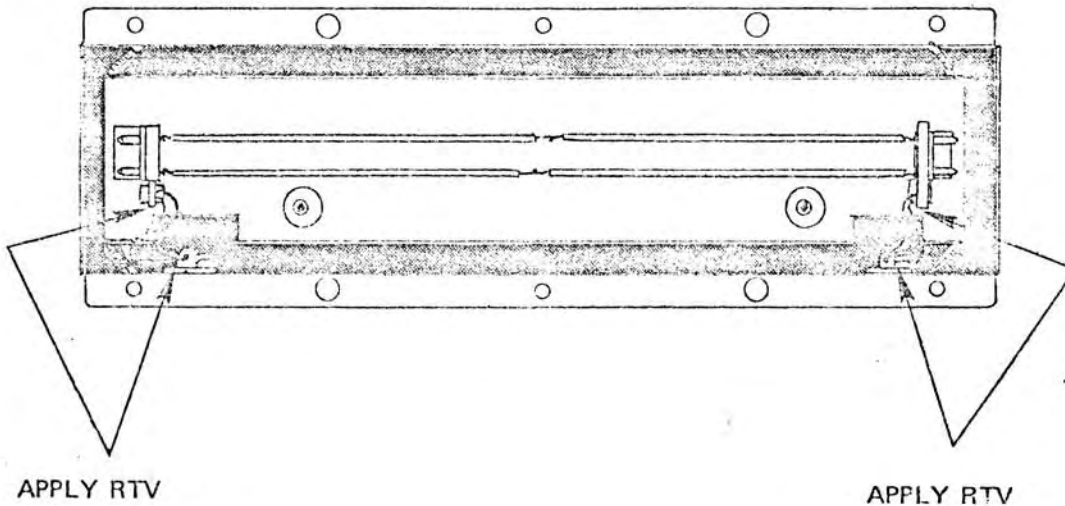



SERVICE NOTES

SECTION 5: 2600 UPDATES

5.1 2600 Trigger

PAGE 9 OF 9

Problem:

When interfaced with a String Ensemble, the 2600's keyboard cannot trigger the ADSR.

Cause:

To synthesize a delayed trigger, the trigger output of the 2600 is processed through one of the inverters in the voltage processors on the 2600. Since the inverter outputs are low impedance, the trigger from the keyboard is grounded out by the inverter.

Solution:

Add a blocking diode in a patch cord from the inverter output to the trigger input of the 2600.

DETAILS OF CHANGE:

Materials Required:

1	IN4148	DIODE
1		PATCH CORD

Procedure:

1. Cut open the patch cord and connect the diode in series with the hot lead.
2. Mark the patch cord to identify anode.
3. Insert the patch cord, anode to inverter output and cathode to trigger input.



SERVICE MANUAL CORRECTION

SMC-004

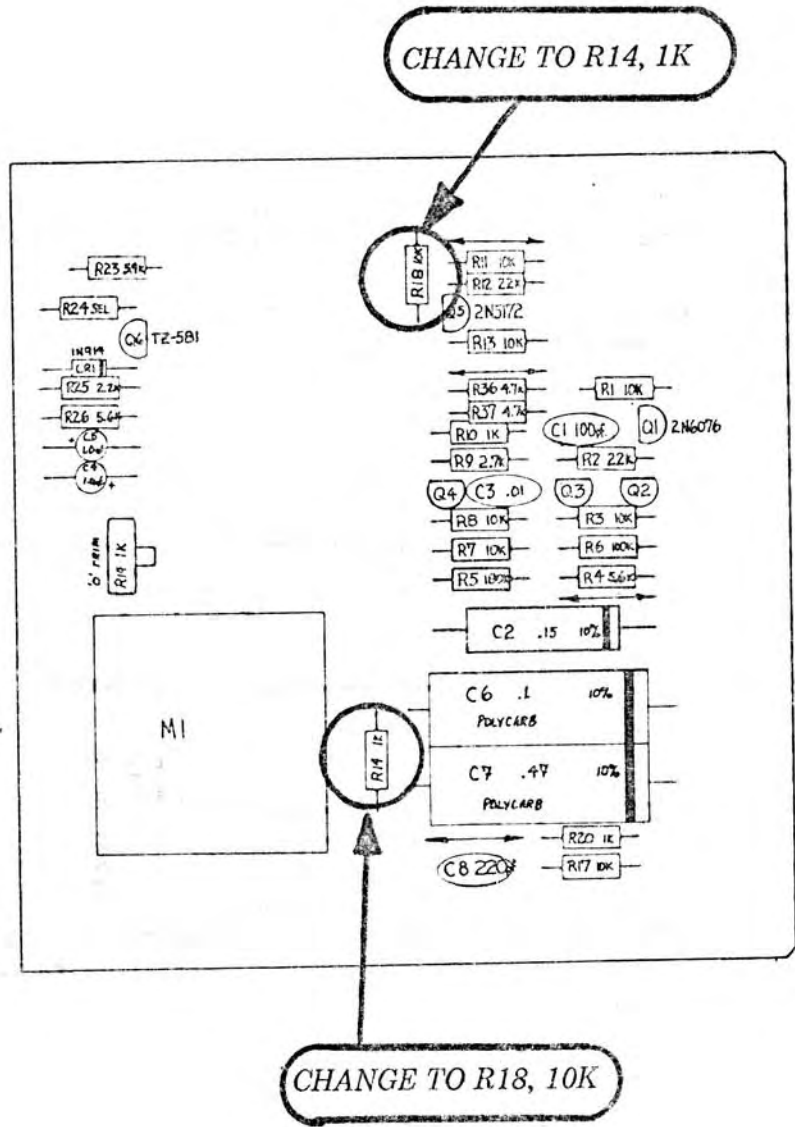

FOIL SIDE VIEW



3604P KEYBOARD ELECTRONICS SCHEMATIC

SERVICE MANUAL CORRECTION

SMC-003

CHANGE TO R13

CHANGE TO R11

- ADD
- CABLE PINS:
1. GROUND
 2. CV OUTPUT
 3. -15 VOLTS
 4. +15 VOLTS
 5. GATE OUT
 6. TRIGGER OUTPUT

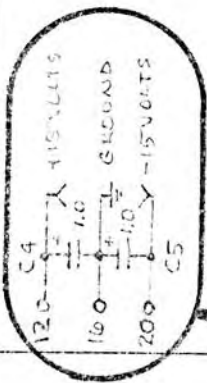
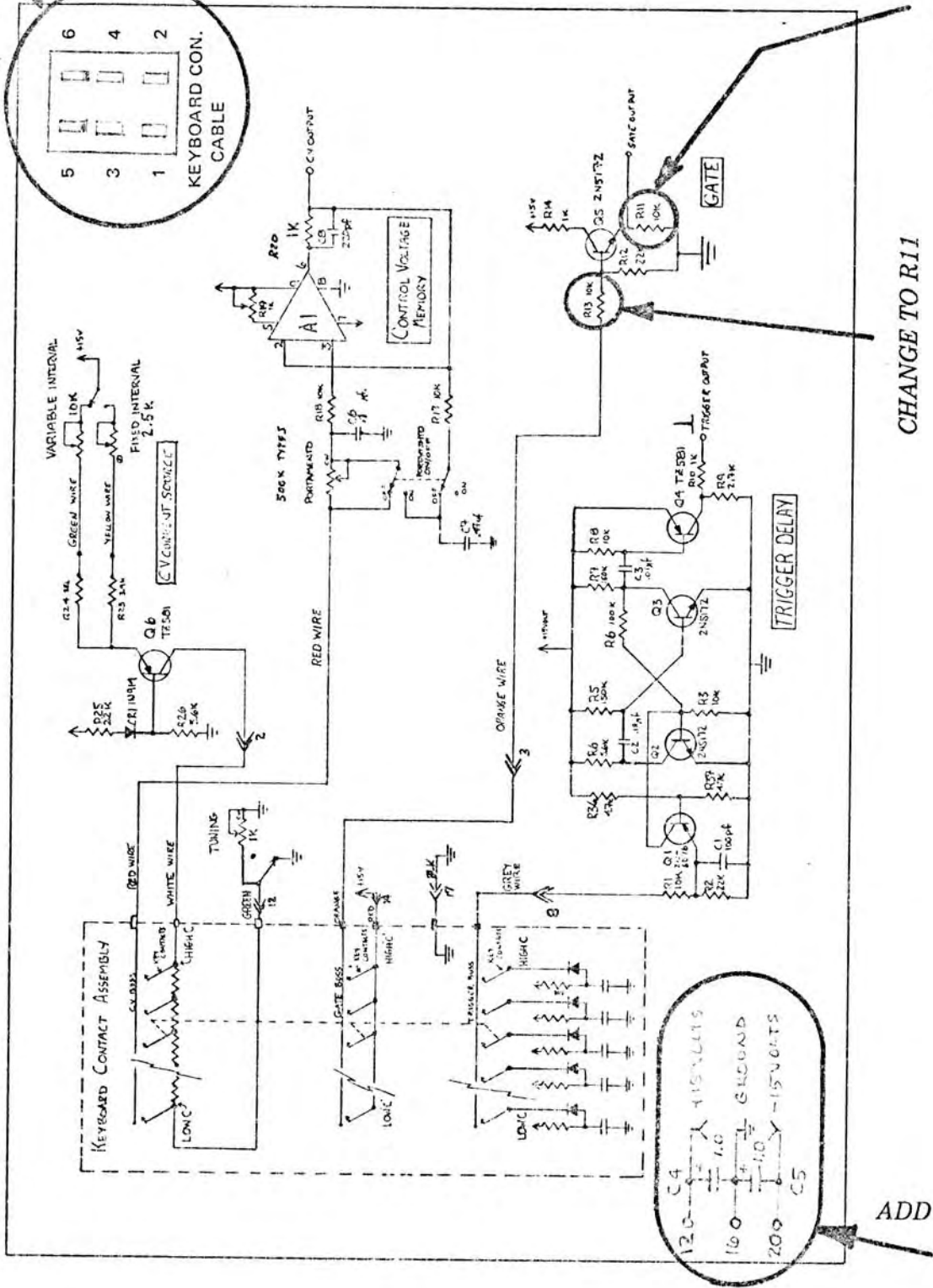
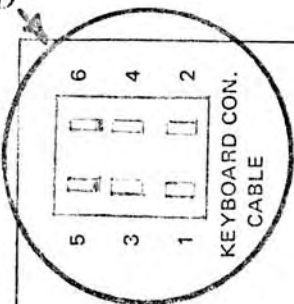

SERVICE MANUAL CORRECTION

PAR 2600
Pd. 4A
AR-ADSR-VCA

SMC-002

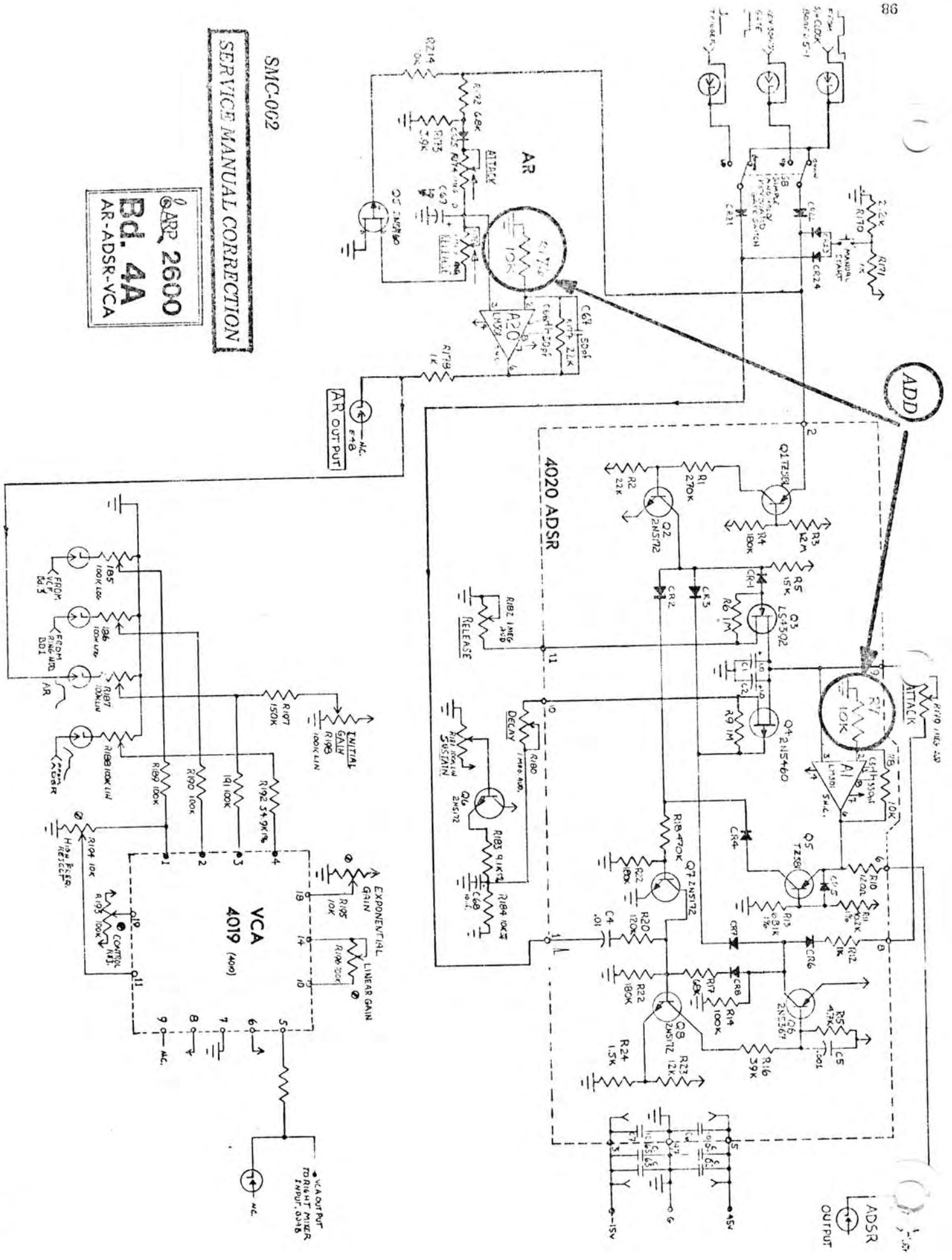

ADD

ATTACK

ADSR OUTPUT

AR OUTPUT

VCA OUTPUT

EXPONENTIAL GAIN

LINEAR GAIN

VCA 4019 (400)

4020 ADSR

AR

SERVICE MANUAL CORRECTION

PAR 2600
Pd. 4A
AR-ADSR-VCA

SMC-002

1-4

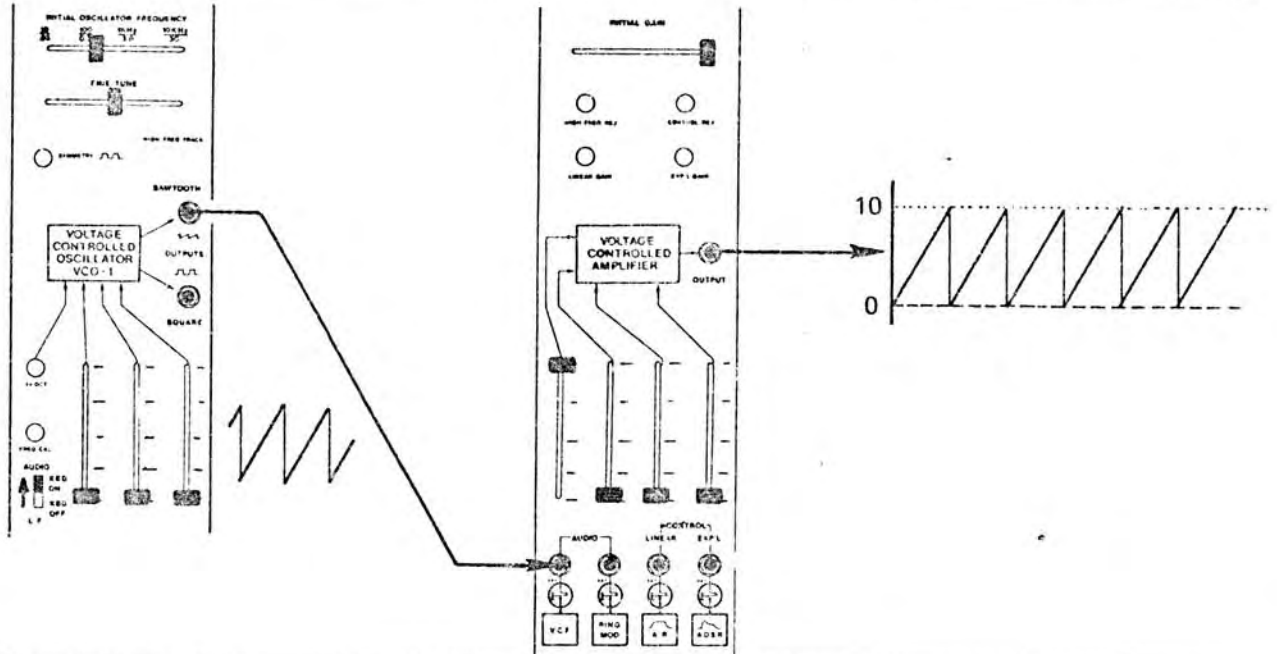

5-7

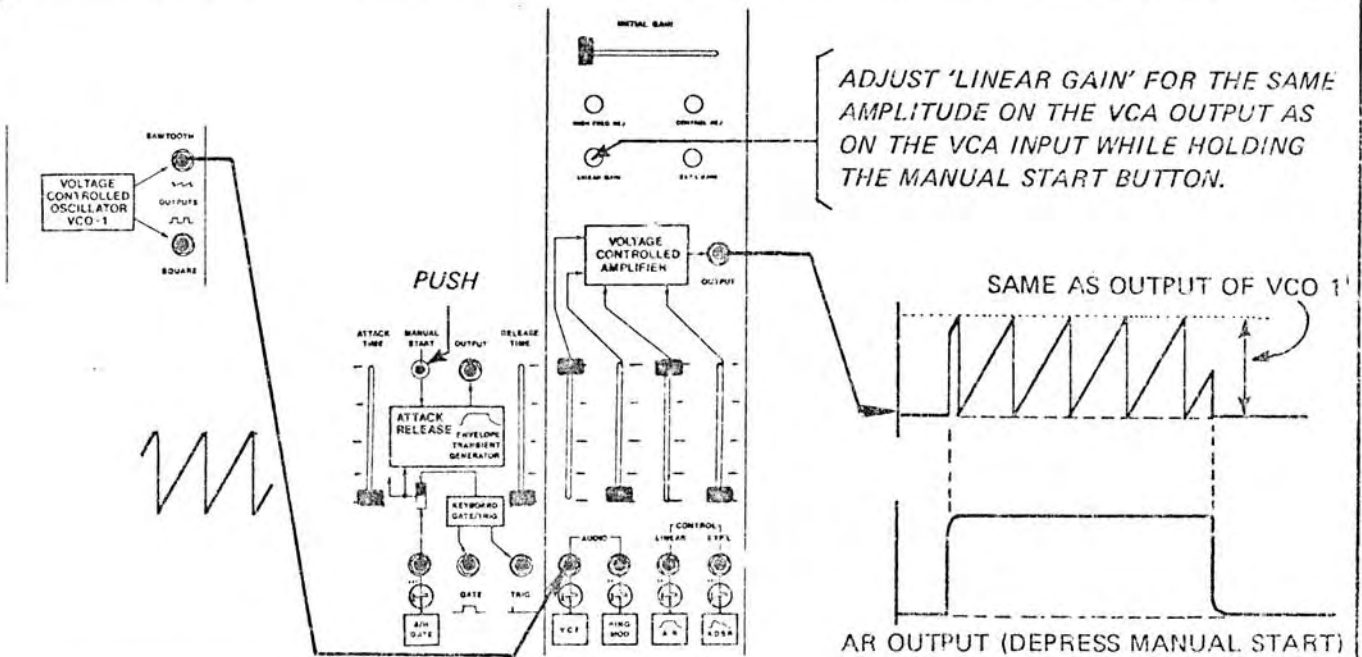

8-10

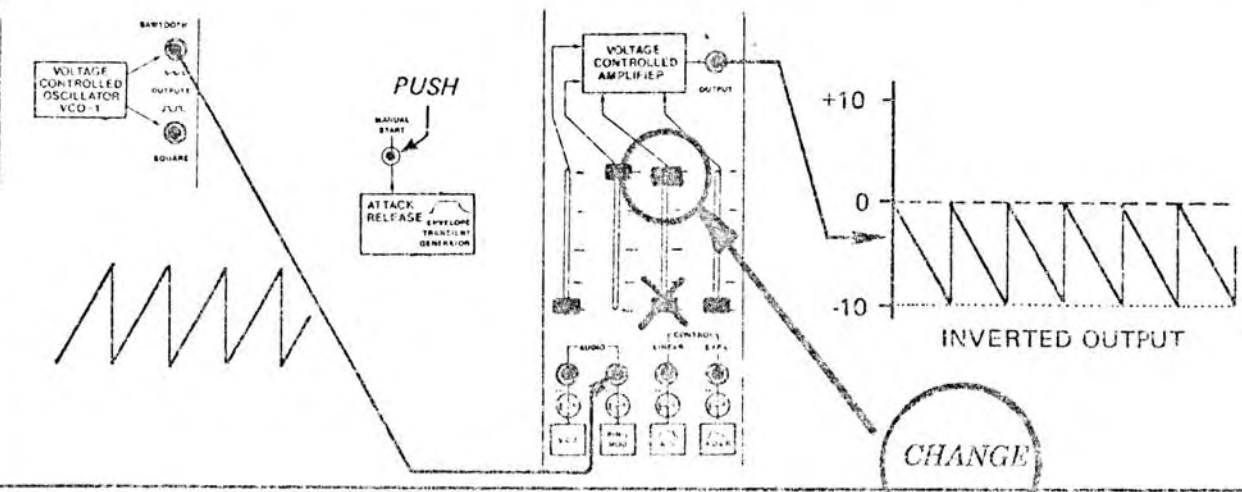



SERVICE NOTES

MODEL: 2600

DATE: 10-29-74

SUBJECT: 2600 SERVICE MANUAL CORRECTIONS

PAGE 1 of 5

THE FOLLOWING CORRECTIONS SHOULD BE MADE TO YOUR 2600 SERVICE MANUAL:

PAGE 43: Linear input to the VCA should be shown with the input slider fully UP on steps 8 through 10.

PAGE 98,33 & 37: A 10K resistor should be shown from pin 2 of A20 (AR circuit) and A1 (ADSR circuit) to ground.

PAGE 106: The keyboard connecting cable pin connections should be shown, the power supply filter capacitors should be shown and R13 and R11 should have their reference designations reversed.

PAGE 107: R14 and R18 should be reversed on the layout.



SERVICE NOTES

MODEL: 2600

DATE: 10-25-74

SUBJECT: KEYBOARD CONNECTING CABLE

PROBLEM: The keyboard interval setting changes and the pitch of the oscillators tends to go flat at the upper end of the keyboard.

CAUSE: The keyboard connecting cable is not making a good electrical connection to the 2600 console (Especially with the non-molded type connector).

SOLUTION: Clean both the male and female ends of the keyboard connecting cable and 2600 console with tuner cleaner or other suitable cleaning solvent. If necessary, twist the pins on the cable and the keyboard about five degrees to insure a good electrical connection.

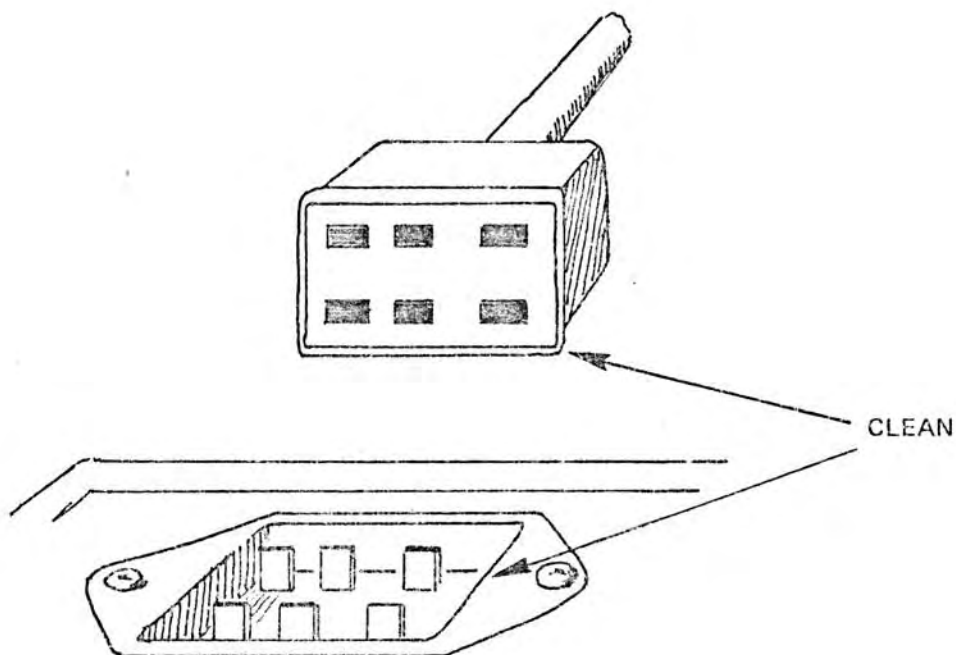



SERVICE NOTES

MODEL: 2600

DATE: 9-25-74

SUBJECT: MINI JACK REPAIRS

PROBLEM: Mini jack fails to conduct from the tip to the shunt.

CAUSE: Tip wire of the mini jack is under tension from the solder mounting.

SOLUTION: Heat the tip wire solder connection and push the tip wire down to the correct position.

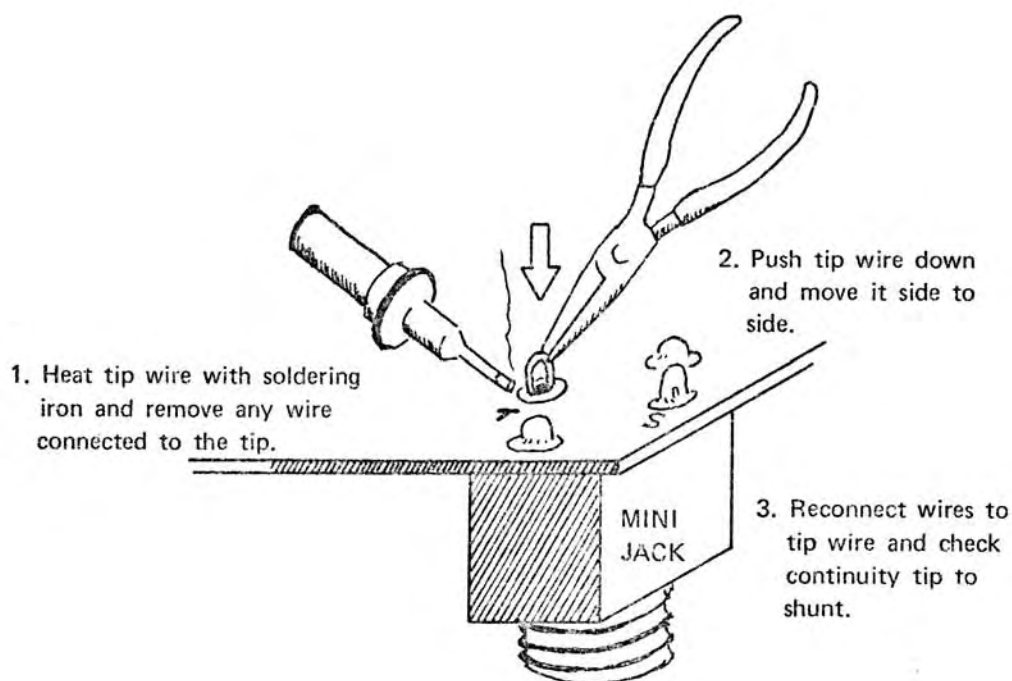

NOTE: See section 6 of the 2600 SERVICE MANUAL for details of mini jack repairs.



SN-002

SERVICE NOTES

MODEL: 2600

DATE: 9-25-74

SUBJECT: MATING 2600 MAIN CONSOLE TO 3604P KEYBOARD

PROBLEM: All three oscillators on the 2600 are in tune with each other across the whole keyboard but the octaves are incorrect.

CAUSE: When the 2600 or the 3604P are serviced separately they may be adjusted to a slightly different standard resulting in a slightly different interval setting.

SOLUTION: Reset the fixed interval control on the keyboard.

2600 CONSOLE AND 3604P MATING PROCEDURE:

1. Put all of the slide switches on the keyboard in the righthand position.
2. Pin low 'C' on the keyboard.
3. Using the 'Initial Frequency' slider on the front panel of one of the oscillators, tune the oscillator to a frequency standard (100 Hz. on a frequency counter, low 'C' on a strobe tuner, or to another oscillator which has been disconnected the keyboard).
4. Pin the highest 'C' on the keyboard.
5. Using a large screwdriver, adjust the 'Fixed Interval' control on the keyboard for exactly four octaves higher than low 'C'. **DO NOT LOOSEN THE LOCKING NUT WHILE ADJUSTING THE FIXED INTERVAL CONTROL.**

NOTE: See section 3 of the 2600 SERVICE MANUAL if the voltage controlled oscillators are out of tune with each other across the keyboard.

○ = New style jack

